



EUROPEAN
CHAMPION
★ 2x ★

NATIONAL
CHAMPION
69x

CAR
OF THE
YEAR
3x

SOUTH
AMERICAN
CHAMPION
2x

ROAR
NATIONALS
CHAMPION

ROAR
NATIONALS
CHAMPION
JUNIOR

★
WORLD
CHAMPIONSHIP
TQ

★
WORLD
VICE-CHAMPION

XRAY

1/8 LUXURY NITRO OFF-ROAD BUGGY

XB8

INSTRUCTION MANUAL

INTRODUCTION

The XRAY XB8 is a modern, high-competition premium luxury racing 1/8 nitro off-road car that is the epitome of high-performance and fine distinctive design. Your XB8 offers highest performance, responsive handling, and traditionally exceptional XRAY quality, engineering, and design. The superb craftsmanship and attention to detail are clearly evident everywhere on the XRAY XB8.

XB8 was designed around a no compromise platform; the attention to detail creates a low maintenance, extra long life nitro buggy. The ultra-low center of gravity (CG) and optimized weight balance makes set-up, driving, and maintenance easy and quick.

CUSTOMER SUPPORT

We have made every effort to make these instructions as easy to understand as possible. However, if you have any difficulties, problems, or questions, please do not hesitate to contact the XRAY support team at info@teamxray.com. Also, please visit our Web site at www.teamxray.com to find the latest updates, set-up information, option parts, and many other goodies. We pride ourselves on taking excellent care of our customers.

You can join thousands of XRAY fans and enthusiasts in our online community at: www.teamxray.com

The XRAY XB8 was created by blending highest-quality materials and excellent design. On high-speed flat tracks or bumpy tracks, whether driving for fun or racing to win, the XB8 delivers outstanding performance, speed, and precision handling.

We have made every effort to make these instructions as easy to understand as possible. However, if you have any difficulties, problems, or questions, please do not hesitate to contact the XRAY support team at info@teamxray.com. Also, please visit our web site at www.teamxray.com to find the latest updates, set-up information, option parts, and many other goodies. We pride ourselves on taking excellent care of our customers.

XRAY Europe

K Výstavisku 6992
91101 Trenčín
Slovakia, EUROPE
Phone: +421-32-7401100
Fax: +421-32-7401109
Email: info@teamxray.com

XRAY USA

RC America, 2030 Century Center Blvd #15
Irving, TX 75062
USA
Phone: (214) 744-2400
Fax: (214) 744-2401
Email: xray@rcamerica.com

FAILURE TO FOLLOW THESE INSTRUCTIONS WILL BE CONSIDERED AS ABUSE AND/OR NEGLECT.

SAFETY PRECAUTIONS

WARNING: This product contains a chemical known to the state of California to cause cancer and birth defects or other reproductive harm.

CAUTION: CANCER HAZARD

Wash thoroughly after using. DO NOT use product while eating, drinking or using tobacco products. May cause chronic effects to gastrointestinal tract, CNS, kidneys, and blood. MAY CAUSE BIRTH DEFECTS.

When building, using and/or operating this model always wear protective glasses and gloves.

Take appropriate safety precautions prior to operating this model. You are responsible for this model's assembly and safe operation! Please read the instruction manual before building and operating this model and follow all safety precautions. Always keep the instruction manual at hand for quick reference, even after completing the assembly. Use only genuine and original authentic

XRAY parts for maximum performance. Using any third party parts on this model will void guaranty immediately.

Improper operation may cause personal and/or property damage. XRAY and its distributors have no control over damage resulting from shipping, improper construction, or improper usage. XRAY assumes and accepts no responsibility for personal and/or property damages resulting from the use of improper building materials, equipment and operations. By purchasing any item produced by XRAY, the buyer expressly warrants that he/she is in compliance with all applicable federal, state and local laws and regulation regarding the purchase, ownership and use of the item. The buyer expressly agrees to indemnify and hold harmless XRAY for all claims resulting directly or indirectly from the purchase, ownership or use of the product. By the act of assembling or operating this product, the user accepts all resulting liability. If the buyer is not prepared to accept this liability, then he/she should return this kit in new, unassembled, and unused condition to the place of purchase.

IMPORTANT NOTES - GENERAL

- This product is not suitable for children under 16 years of age without the direct supervision of a responsible and knowledgeable adult.
- Carefully read all manufacturers warnings and cautions for any parts used in the construction and use of your model.
- Assemble this kit only in places away from the reach of very small children.
- First-time builders and users should seek advice from people who have building experience in order to assemble the model correctly and to allow the model to reach its performance potential.
- Exercise care when using tools and sharp instruments.
- Take care when building, as some parts may have sharp edges.
- Keep small parts out of reach of small children. Children must not be allowed to put any parts in their mouth, or pull vinyl bag over their head.
- Read and follow instructions supplied with paints and/or cement, if used (not included in kit).
- Immediately after using your model, do NOT touch equipment on the model such as the motor and speed controller, because they generate high temperatures. You may seriously burn yourself seriously touching them.
- Follow the operating instructions for the radio equipment at all times.
- Do not put fingers or any objects inside rotating and moving parts, as this may cause damage or serious injury as your finger, hair, clothes, etc. may get caught.
- Be sure that your operating frequency is clear before turning on or running your model, and never share the same frequency with somebody else at the same time. Ensure that others are aware of the operating frequency you are using and when you are using it.
- Use a transmitter designed for ground use with RC cars. Make sure that no one else is using the same frequency as yours in your operating area. Using the same frequency at the same time, whether it is driving, flying or sailing, can cause loss of control of the RC model, resulting in a serious accident.
- Always turn on your transmitter before you turn on the receiver in the car. Always turn off the receiver before turning your transmitter off.

- Keep the wheels of the model off the ground when checking the operation of the radio equipment.
- Disconnect the battery pack before storing your model.
- When learning to operate your model, go to an area that has no obstacles that can damage your model if your model suffers a collision.
- Remove any sand, mud, dirt, grass or water before putting your model away.
- If the model behaves strangely, immediately stop the model, check and clear the problem.
- To prevent any serious personal injury and/or damage to property, be responsible when operating all remote controlled models.
- The model car is not intended for use on public places and roads or areas where its operation can conflict with or disrupt pedestrian or vehicular traffic.
- Because the model car is controlled by radio, it is subject to radio interference from many sources that are beyond your control. Since radio interference can cause momentary loss of control, always allow a safety margin in all directions around the model in order to prevent collisions.
- Do not use your model:
 - Near real cars, animals, or people that are unaware that an RC car is being driven.
 - In places where children and people gather
 - In residential districts and parks
 - In limited indoor spaces
 - In wet conditions
 - In the street
 - In areas where loud noises can disturb others, such as hospitals and residential areas.
 - At night or anytime your line of sight to the model may be obstructed or impaired in any way.

To prevent any serious personal injury and/or damage to property, please be responsible when operating all remote controlled models.

IMPORTANT NOTES - NITRO ENGINES

- Always test the brakes and the throttle before starting your engine to avoid losing control of the model.
- Make sure the air filter is clean and oiled.
- Never run your engine without an air filter. Your engine can be seriously damaged if dirt and debris get inside the engine.

- For proper engine break-in, please refer to the manual that came with the engine.
- Do not run near open flames or smoke while running your model or while handling fuel.
- Some parts will be hot after operation. Do not touch the exhaust or the engine until they have cooled. These parts may reach 275°F during operation!

IMPORTANT NOTES - ELECTRICAL

- Insulate any exposed electrical wiring (using heat shrink tubing or electrical tape) to prevent dangerous short circuits. Take maximum care in wiring, connecting and insulating cables. Make sure cables are always connected securely. Check connectors for if they become loose. And if so, reconnect them securely. Never use R/C models with damaged wires. A damaged wire is extremely dangerous, and can cause short-circuits resulting in fire. Please have wires repaired at your local hobby shop.
- Low battery power will result in loss of control. Loss of control can occur due to a weak battery in either the transmitter or the receiver. Weak running battery may also result in an out of control car if your car's receiver power is supplied by the running battery. Stop operation immediately if the car starts to slow down.
- When not using RC model, always disconnect and remove battery.
- Do not disassemble battery or cut battery cables. If the running battery short-circuits, approximately 300W of electricity can be discharged, leading to fire or burns. Never disassemble battery or cut battery cables.
- Use a recommended charger for the receiver and transmitter batteries and follow the instructions correctly. Over-charging, incorrect charging, or using

inferior chargers can cause the batteries to become dangerously hot. Recharge battery when necessary. Continual recharging may damage battery and, in the worst case, could build up heat leading to fire. If battery becomes extremely hot during recharging, please ask your local hobby shop for check and/or repair and/or replacement.

- Regularly check the charger for potential hazards such as damage to the cable, plug, casing or other defects. Ensure that any damage is rectified before using the charger again. Modifying the charger may cause short-circuit or overcharging leading to a serious accident. Therefore do not modify the charger.
- Always unplug charger when recharging is finished.
- Do not recharge battery while battery is still warm. After use, battery retains heat. Wait until it cools down before charging.
- Do not allow any metal part to short circuit the receiver batteries or other electrical/electronic device on the model.
- Immediately stop running if your RC model gets wet as may cause short circuit.
- Please dispose of batteries responsibly. Never put batteries into fire.

IMPORTANT NOTES - NITRO FUEL

- Handle fuel only outdoors. Never handle nitro fuel indoors, or mix nitro fuel in a place where ventilation is bad.
- Only use nitro fuel for R/C models. Do not use gasoline or kerosene in R/C models as it may cause a fire or explosion, and ruin your engine.
- Nitro fuel is highly flammable, explosive, and poisonous. Never use fuel indoors or in places with open fires and sources of heat.
- Always keep the fuel container cap tightly shut.
- Always read the warning label on the fuel container for safety information.
- Nitro-powered model engines emit poisonous vapors and gasses. These vapors irritate eyes and can be highly dangerous to your health. We recommend wearing rubber or vinyl gloves to avoid direct contact with nitro fuel.
- Nitro fuel for RC model cars is made of the combination of the methyl alcohol,

castor or synthetic oil, nitro methane etc. The flammability and volatility of these elements is very high, so be very careful during handling and storage of nitro fuel.

- Keep nitro fuel away from open flame, sources of heat, direct sunlight, high temperatures, or near batteries.
- Store fuel in a cool, dry, dark, well-ventilated place, away from heating devices, open flames, direct sunlight, or batteries. Keep nitro fuel away from children.
- Do not leave the fuel in the carburetor or fuel tank when the model is not in use. There is danger that the fuel may leak out.
- Wipe up any spilled fuel with a cloth.
- Be aware of spilled or leaking fuel. Fuel leaks can cause fires or explosions.
- Do not dispose of fuel or empty fuel containers in a fire. There is danger of explosion.

R/C & BUILDING TIPS

- Make sure all fasteners are properly tightened. Check them periodically.
- Make sure that chassis screws do not protrude from the chassis.
- For the best performance, it is very important that great care is taken to ensure the free movement of all parts.
- Clean all ball-bearings so they move very easily and freely.
- Tap or pre-thread the plastic parts when threading screws.
- Self-tapping screws cut threads into the parts when being tightened. Do not use excessive force when tightening the self-tapping screws because you may strip out the thread in the plastic. We recommended you stop tightening a screw when you feel some resistance.

- Ask your local hobby shop for any advice.

Please support your local hobby shop. We at XRAY Model Racing Cars support all local hobby dealers. Therefore we ask you, if at all possible, to purchase XRAY products at your hobby dealer and give them your support like we do. If you have difficulty finding XRAY products, please check out www.teamxray.com to get advice, or contact us via email at info@teamxray.com, or contact the XRAY distributor in your country.

WARRANTY

XRAY guarantees this model kit to be free from defects in both material and workmanship within 30 days of purchase. The total monetary value under warranty will in no case exceed the cost of the original kit purchased. This warranty does not cover any components damaged by use or modification or as a result of wear. Part or parts missing from this kit must be reported within 30 days of purchase. No part or parts will be sent under warranty without proof of purchase. Should you find a defective or missing part, contact the local distributor. Service and customer support will be provided through local hobby store where you have purchased the kit, therefore make sure to purchase any XRAY products at your local hobby store. This model racing car is considered to be a high-performance racing vehicle. As such this vehicle will be used in an extreme range of conditions and situations, all which may cause premature wear or failure of any component. XRAY has no control over usage of vehicles once they leave the dealer, therefore XRAY can only offer warranty against all manufacturer's defects in materials, workmanship, and assembly at point of sale and before use. No warranties are expressed or implied that cover damage caused by what is considered normal use, or cover or imply how long any model cars' components or electronic components will last before requiring replacement.

Due to the high performance level of this model car you will need to periodically maintain and replace consumable components. Any and all warranty coverage will not cover replacement of any part or component damaged by neglect, abuse, or improper or unreasonable use. This includes but is not limited to damage

from crashing, chemical and/or water damage, excessive moisture, improper or no maintenance, or user modifications which compromise the integrity of components. Warranty will not cover components that are considered consumable on RC vehicles. XRAY does not pay nor refund shipping on any component sent to XRAY or its distributors for warranty. XRAY reserves the right to make the final determination of the warranty status of any component or part.

Limitations of Liability

XRAY makes no other warranties expressed or implied. XRAY shall not be liable for any loss, injury or damages, whether direct, indirect, special, incidental, or consequential, arising from the use, misuse, or abuse of this product and/or any product or accessory required to operate this product. In no case shall XRAY's liability exceed the monetary value of this product.

Take adequate safety precautions prior to operating this model. You are responsible for this model's assembly and safe operation.

Disregard of the any of the above cautions may lead to accidents, personal injury, or property damage. XRAY MODEL RACING CARS assumes no responsibility for any injury, damage, or misuse of this product during assembly or operation, nor any additions that may arise from the use of this product. All rights reserved.

QUALITY CERTIFICATE

XRAY MODEL RACING CARS uses only the highest quality materials, the best compounds for molded parts and the most sophisticated manufacturing processes of TQM (Total Quality Management). We guarantee that all parts of a newly-purchased kit are manufactured with the highest regard to quality. However, due to the many factors inherent in model racecar competition, we cannot guarantee

any parts once you start racing the car. Products which have been worn out, abused, neglected or improperly operated will not be covered under warranty. We wish you enjoyment of this high-quality and high-performance RC car and wish you best success on the track!

In line with our policy of continuous product development, the exact specifications of the kit may vary. In the unlikely event of any problems with your new kit, you should contact the model shop where you purchased it, quoting the part number. We do reserve all rights to change any specification without prior notice. All rights reserved.

SYMBOLS USED

Part bags used 	Assemble in the specified order 	Assemble left and right sides the same way 	Assemble front and rear the same way 	Pay attention here 	Assemble as many times as specified (here twice) 	Apply instant glue 	Apply oil 	Apply grease 	Apply threadlock
Cut off shaded portion 	Use special tool 	Cut off remaining material 	Time 	Use cleaner or WD-40® 	Tighten screw gently 	Ensure smooth non-binding movement 	Use pliers 	Follow tip here 	Follow Set-up Book

TOOLS REQUIRED

<ul style="list-style-type: none"> Phillips 5.0mm (HUDY TOOLS) Allen 1.5/2.0/2.5/3.0mm (HUDY TOOLS) Ball Allen 2.5mm (HUDY TOOLS) Arm Reamer 3mm/4mm (HUDY TOOLS) Socket 5.0/5.5mm (HUDY TOOLS) 	Professional Multi Tool (HUDY #183011) 	17mm Wheel Nut Tool (HUDY #107570) 	Flywheel Tool (HUDY #182015) 	Special Tool for all turnbuckles, nuts (HUDY #181090) Turnbuckle Wrench (HUDY #181040 4mm) (HUDY #181050 5mm)	Cross Wrench (HUDY #107581)
Side Cutters (HUDY #189010) 	Pocket Hobby Knife (HUDY #188981) 	Needle Nose Pliers (HUDY #189020) 	Snap Ring Pliers (HUDY #189040) 	Scissors (HUDY #188990) 	Body Reamer (HUDY #107600) or (HUDY #107601)

TOOLS & EQUIPMENT INCLUDED

Silicone Shock Oil (HUDY #106336 350cSt 100ml) (HUDY #106346 450cSt 100ml) 	Silicone Diff Oil (HUDY #106431 3000cSt 100ml) (HUDY #106461 6000cSt 100ml) (HUDY #106471 7000cSt 100ml) 	Air Filter Oil (HUDY #106240) 	Graphite Grease (HUDY #106210)
---	--	---	--

NOT INCLUDED

SET-UP BOOK

To ensure that you always have access to the most up-to-date version of the XRAY Set-up Book, XRAY will now be offering only the digital online version at our website at www.teamxray.com. By offering this online version instead of including a hardcopy printed version in kits, you will always be assured of having the most current updated version.

EQUIPMENT REQUIRED

Transmitter Receiver Steering and Throttle Servos 	.21ci (3.5cc) Engine (FX K302 DC #650102) 	Manifold (FX #659704) Exhaust (FX #659503) 	Starter Box & Battery Pack (HUDY #104500) 	Glow Plug Igniter 	Battery Charger
Receiver Pack 	Threadlock 	CA Glue 	Transmitter Batteries 	Fuel + Fuel Bottle (HUDY #104200) 	Lexan™ Paint

TIP FRONT & REAR DIFF GEAR MESH ADJUSTMENT

If there is too much or too little diff side play, this may create non-optimal gear mesh between the diff gear and the pinion drive gear. This is easily resolved by inserting 1 or 2 of the included thin shims behind a diff outdrive ball-bearing, depending on how much play there is.

THE LOCATION OF THE SHIM(S) DEPENDS ON WHETHER YOU ARE TRYING TO CLOSE OR OPEN THE GAP:

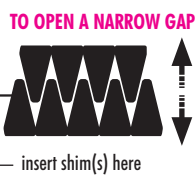
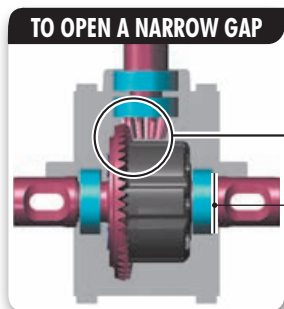
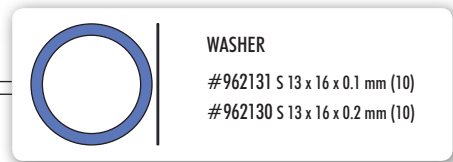
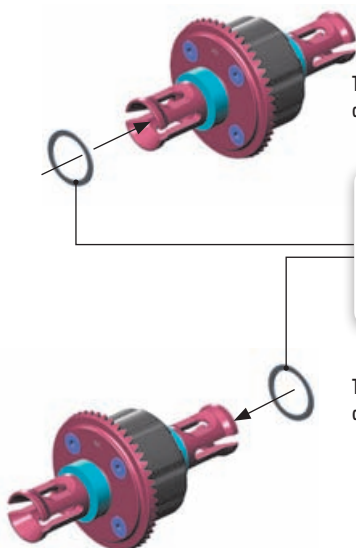
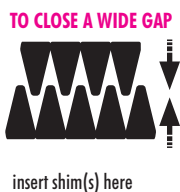
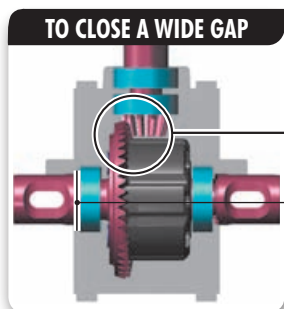

To OPEN a narrow gap:
add 1 or 2 shims on the other side of the diff, away from spur gear

SUSPENSION & DRIVETRAIN MAINTENANCE

- Check suspension for free movement during building and operation, and especially after running and if you have crashed the car. If the suspension does not move freely, use the appropriate HUDY Arm Reamer to clean and resize the holes of the suspension arms.
- Regularly check the drive shaft pins (both side and center) and if they show any wear must be immediately replaced by new pins. If the car is run with worn pins, excessive wear on the diff outdrives will result. The 106000 HUDY Drive Pin Replacement Tool (for 3mm Pins) is a compact, rugged multi-use tool set for replacing 3mm drive pins in drive shafts. Use the HUDY replacement drive shaft pins 3x14 (#106050).
- Regularly inspect and replace the connecting pins which connect the center drive shafts with the pinion gear, and also the pins that connect the wheel drive shafts with wheel axles. Use HUDY Graphite Grease to lubricate the drive shaft connecting joints and the diff gears.
- Pivot balls and ball-joints will naturally wear for some time and will generate play. If there is too much play the pivot balls and ball joints need to be replaced.
- If the car is run in wet conditions, apply WD-40® on all drivetrain parts before the run. After the run, clean and dry the parts again.

HUDY SPRING STEEL™

The HUDY Spring Steel™ used in the car is the strongest and most durable steel material on the RC market. While items made from HUDY Spring Steel™ are still subject to wear, the lifespan is considerably longer than any other material. As parts made from HUDY Spring Steel™ wear, the brown color will after some time "go down" but it will not affect the strength of the material. The brown color is only a surface treatment and if the brown color will wear the durability of the part will be still strong.

TIP DRIVE SHAFT PIN SERVICING

To enjoy the longest possible lifespan of the drive shafts and diff outdrives, it is extremely important to properly service the drive shaft pins. Inspect the pins after every 3 hours of runtime. If the pins show any wear, replace them with new pins.



1 Do not use drive shafts when the pins are worn.

2 Press out the worn pins.

3 Press in new pins and regularly inspect for wear.



For easy drive pin replacements use #106000 HUDY Drive Pin Replacement Tool.



To replace the worn pins use only premium HUDY drive pins #106050.

1. FRONT & REAR DIFFERENTIALS

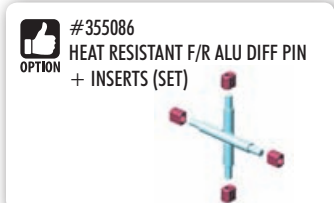
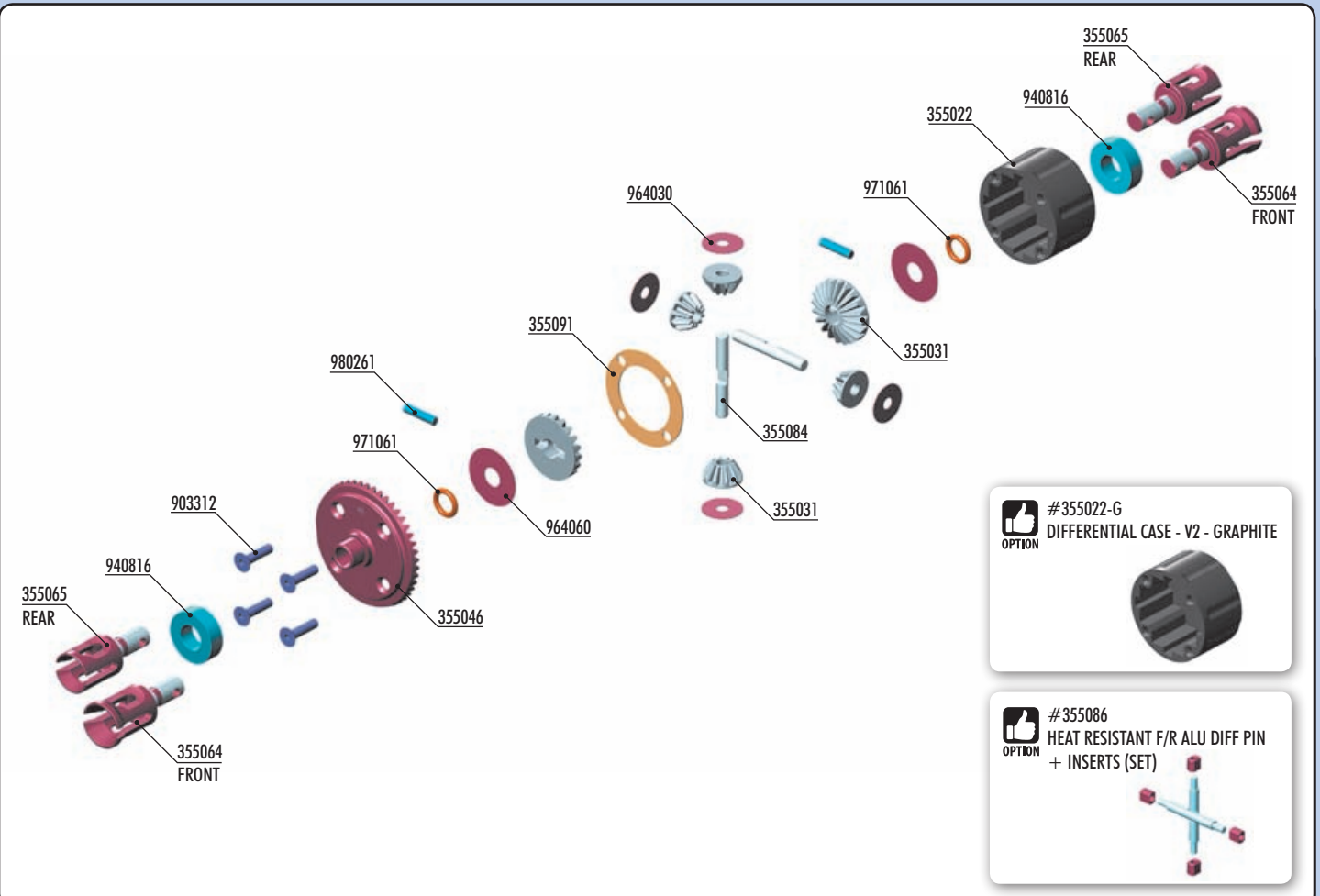

BAGS

01.1

2x

355004	XB8 FRONT DIFFERENTIAL 46T - V2 - SET	355091	F/R DIFF GASKET (4)
355005	XB8 REAR DIFFERENTIAL 46T - V2 - SET	903312	HEX SCREW SFH M3x12 (10)
355022	DIFFERENTIAL CASE - V2	940816	BALL-BEARING 8x16x5 RUBBER SEALED - GREASE (2)
355031	STEEL DIFF BEVEL & SATELLITE GEARS - V2 (2+4)	964030	WASHER S 3.5x12x0.2 (10)
355046	FRONT/REAR DIFF LARGE BEVEL GEAR 46T - HUDY STEEL	964060	WASHER S 6x18x0.2 (10)
355064	FRONT DIFF OUTDRIVE ADAPTER LONG - V2 - HUDY SPRING STEEL™ (2)	971061	SILICONE O-RING 6x1.55 (10)
355065	REAR DIFF OUTDRIVE ADAPTER - V2 - HUDY SPRING STEEL™ (2)	980261	PIN 2.5x11.5 (10)
355084	F/R DIFF PIN (2)		

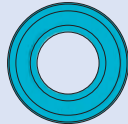

940816
BB 8x16x5



964060
S 6x18x0.2



971061
O 6x1.55



980261
P 2.5x11.5

2x **F=R**

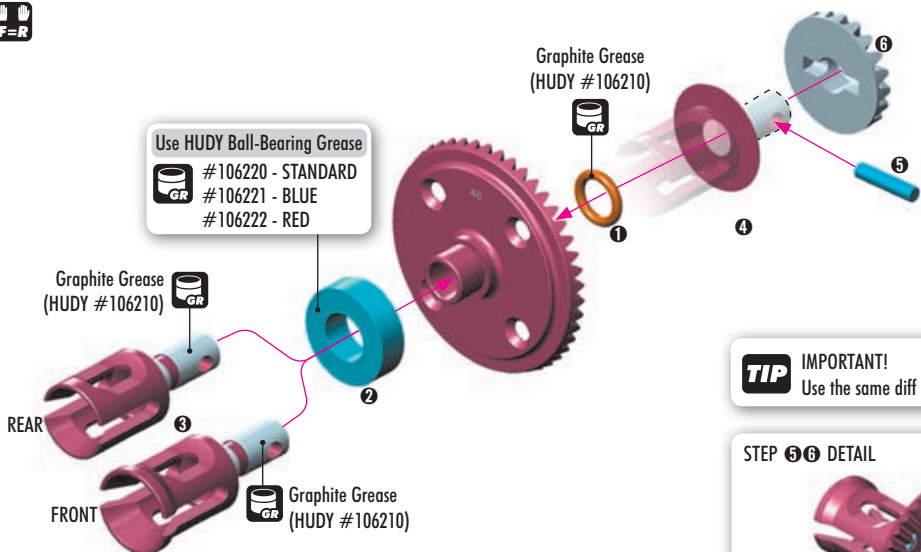

TIP IMPORTANT!
Use the same diff outdrives on both ends of a diff.

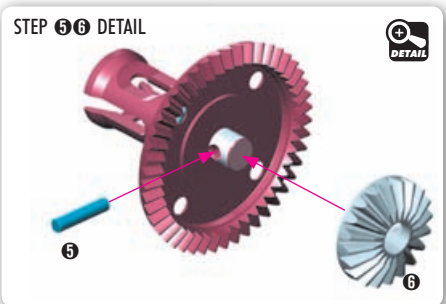

SET-UP BOOK
DIFFERENTIAL GEARS

1. FRONT & REAR DIFFERENTIALS

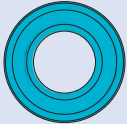

940816
BB 8x16x5



964060
S 6x18x0.2



971061
O 6x1.55



980261
P 2.5x11.5

2x F=R

TIP IMPORTANT!
Use the same diff outrides on both ends of a diff.

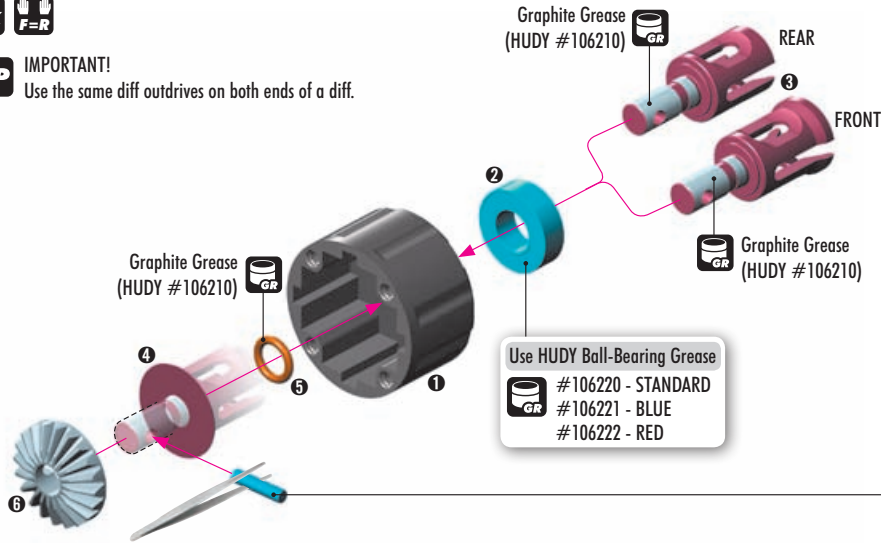

Use HUDY Ball-Bearing Grease
#106220 - STANDARD
#106221 - BLUE
#106222 - RED

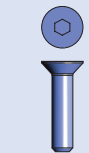
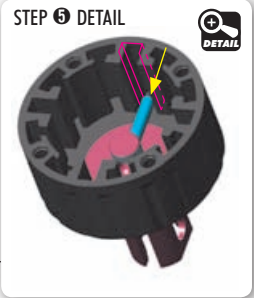

903312
SFH M3x12



964030
S 3.5x12x0.2

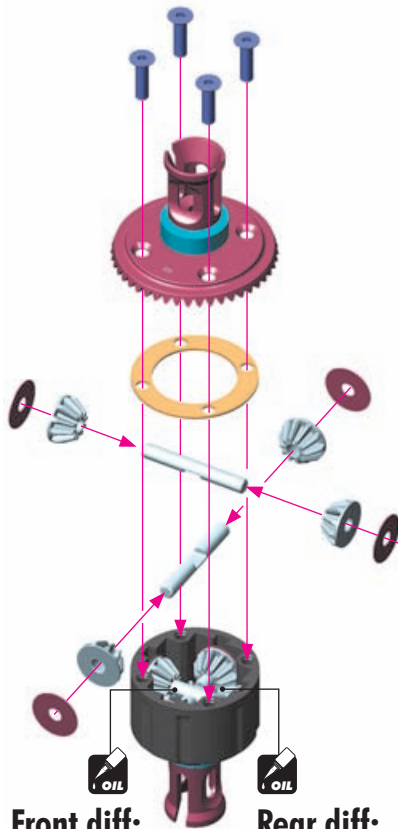

Front diff:

Silicone oil 6 000cSt
Fill just above the satellite gears.

Rear diff:

Silicone oil 3 000cSt
Fill just above the satellite gears.

VERY IMPORTANT!

Use the following silicone oils included in the kit for initial settings:
FRONT diff: 6 000cSt / REAR diff: 3 000cSt

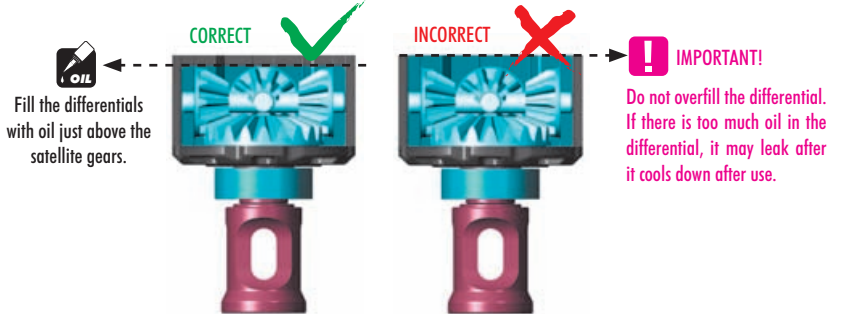

Fill the differentials with oil just above the satellite gears.

IMPORTANT!
Do not overfill the differential. If there is too much oil in the differential, it may leak after it cools down after use.

To ensure you have the same amount of oil from rebuild to rebuild, do the following:

#107865 HUDY Ultimate Digital Pocket Scale 300g ± 0.01g



REAR 39.30g
FRONT 40.10g



REAR 42.00g
FRONT 42.80g

1. Put the diff (without oil) on the scale and check the weight:

- REAR DIFF approx. 39.30g
- FRONT DIFF approx. 40.10g

2. Slowly pour oil into the diff and watch the weight. Add 2.70g of oil into the diff. The approximate weight of the diff + oil is REAR DIFF approx. 42.00g and FRONT DIFF approx. 42.80g

$$\text{REAR DIFF } 39.30\text{g} + 2.70\text{g} = 42.00\text{g}$$

$$\text{FRONT DIFF } 40.10\text{g} + 2.70\text{g} = 42.80\text{g}$$

Tighten the screws equally



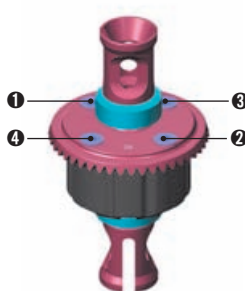

Finish tightening in this order

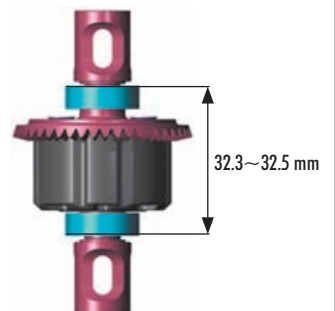

After assembly the differentials should have a length of 32.3~32.5 mm measured from the ends of the installed ball-bearings. If differentials are longer, retighten the 4 screws holding the crown gears.



1. CENTER DIFFERENTIAL

CENTER DIFF SPUR GEARS - LARGE		
	#355056	46T INCLUDED
	#355057	47T OPTION
	#355058	48T OPTION

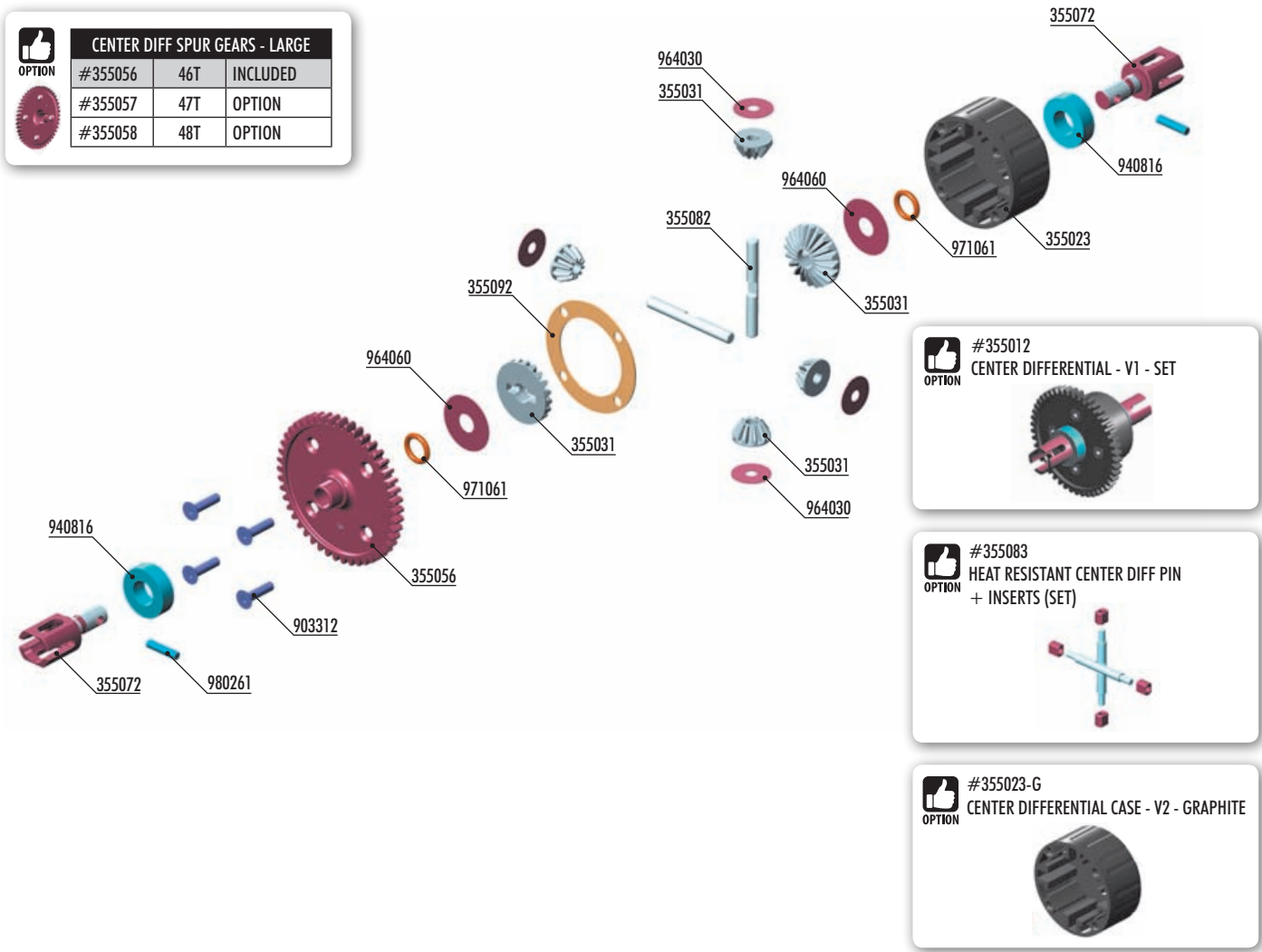

355013	CENTER DIFFERENTIAL - LARGE - SET	903312	HEX SCREW SFH M3x12 (10)
355023	CENTER DIFFERENTIAL CASE - V2	940816	BALL-BEARING 8x16x5 RUBBER SEALED - GREASE (2)
355031	STEEL DIFF BEVEL & SATELLITE GEARS - V2 (2+4)	964030	WASHER S 3.5x12x0.2 (10)
355056	CENTER DIFF SPUR GEAR 46T - LARGE	964060	WASHER S 6x18x0.2 (10)
355072	LARGE CENTER DIFF OUTDRIVE ADAPTER - HUDY STEEL (2)	971061	SILICONE O-RING 6x1.55 (10)
355082	CENTER DIFF PIN (2)	980261	PIN 2.5x11.5 (10)
355092	CENTER DIFF GASKET (2)		

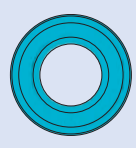

940816
BB 8x16x5

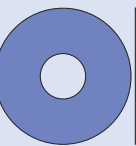

964060
S 6x18x0.2



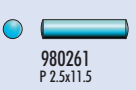

971061
O 6x1.55

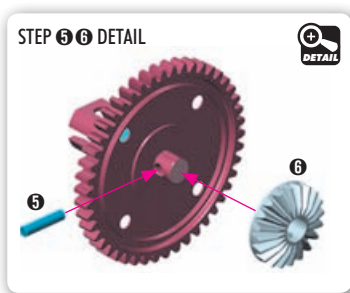
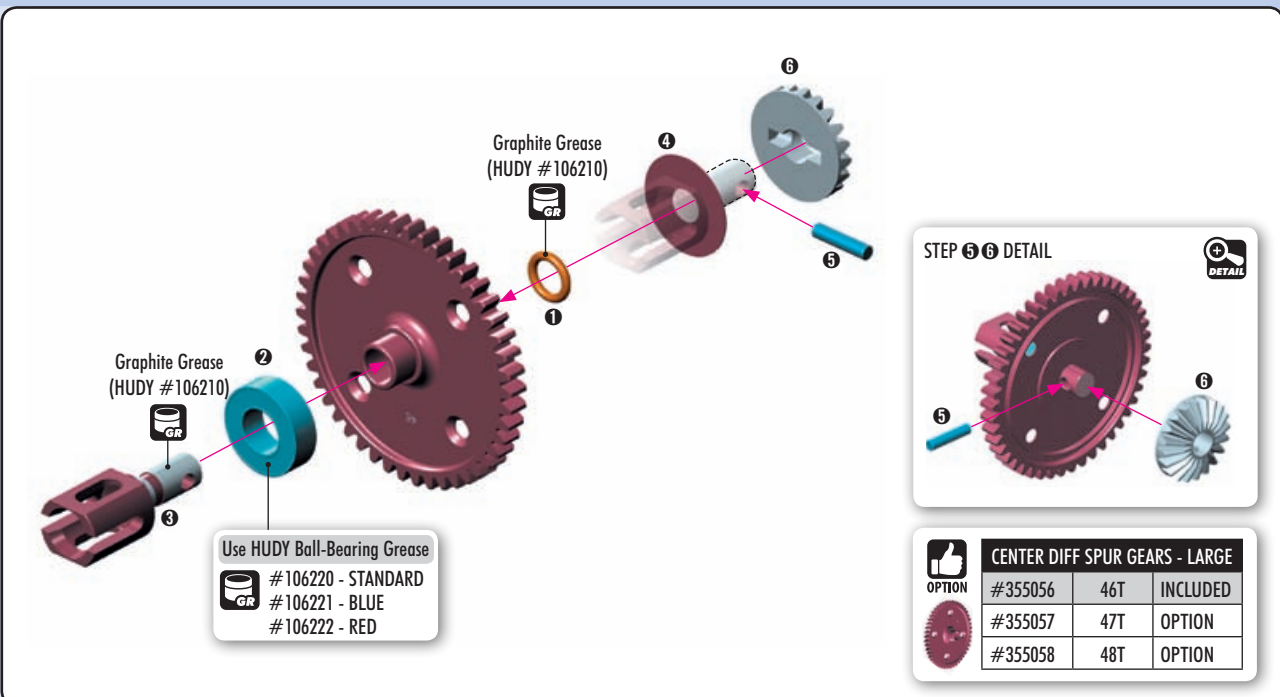

980261
P 2.5x11.5



CENTER DIFF SPUR GEARS - LARGE		
	#355056	46T INCLUDED
	#355057	47T OPTION
	#355058	48T OPTION

1. CENTER DIFFERENTIAL



940816
BB 8x16x5



964060
S 6x18x0.2



971061
O 6x1.55



980261
P 2.5x11.5

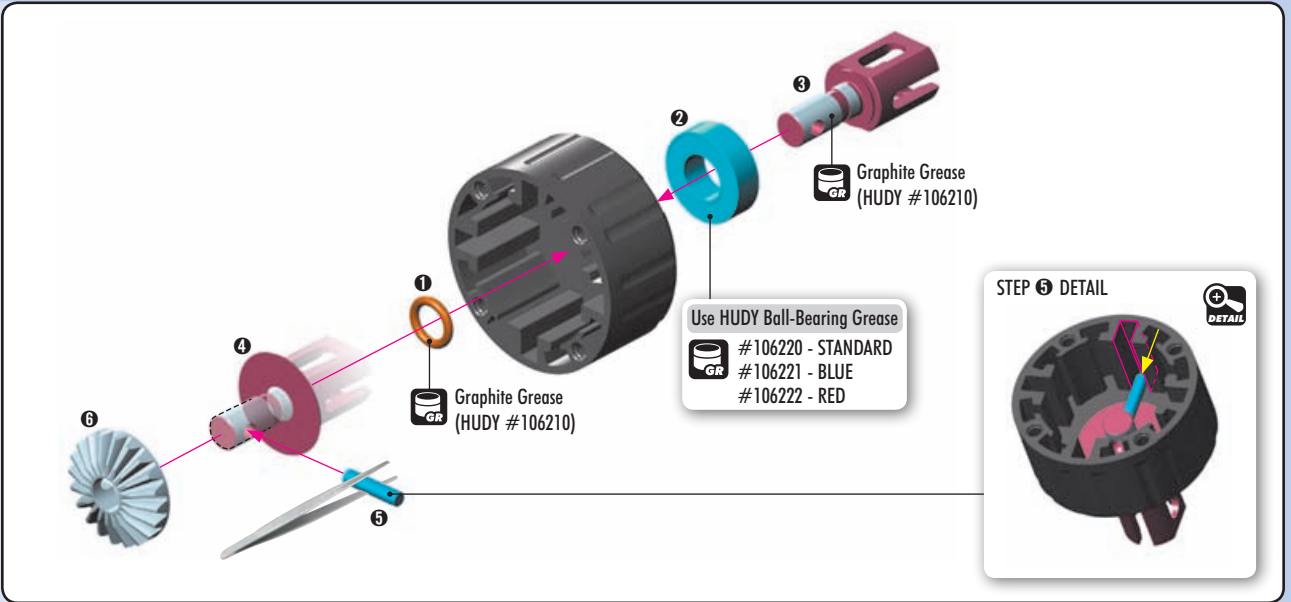

Graphite Grease (HUDY #106210)

Use HUDY Ball-Bearing Grease
#106220 - STANDARD
#106221 - BLUE
#106222 - RED



903312
SFH M3x12



964030
S 3.5x12x0.2

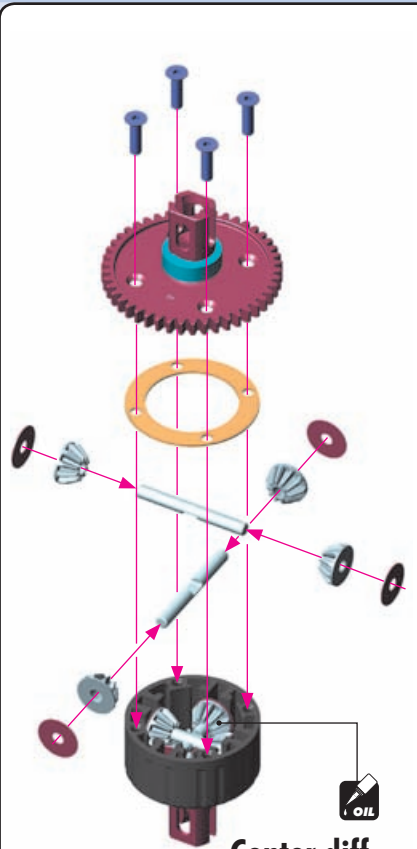

Center diff:
Silicone oil 7 000cSt
Fill to just above the satellite gears.

VERY IMPORTANT!

Use the following silicone oil included in the kit for initial setting:
Center diff: 7 000cSt

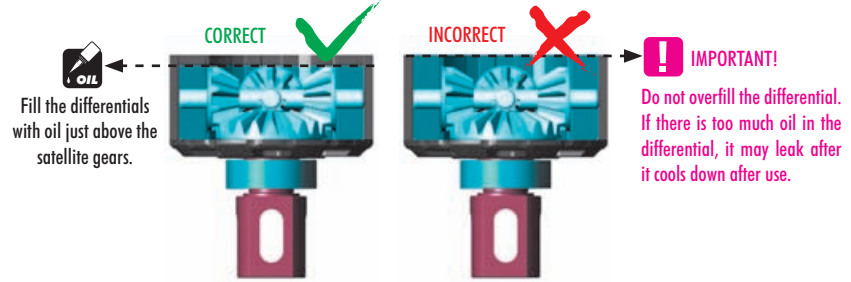

To ensure you have the same amount of oil from rebuild to rebuild, do the following:

#107865 HUDY Ultimate Digital Pocket Scale 300g ± 0.01g

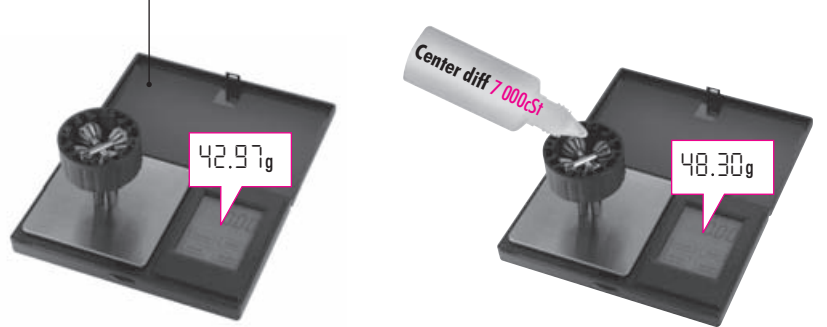

1. Put the diff (without oil) on the scale and check the weight (approximately 42.97g).

2. Slowly pour oil into the diff and watch the weight. Add 5.33g of oil into the diff. The approximate weight of the diff + oil is 48.30g.

CENTER DIFF 42.97g + 5.33g = 48.30g

SET-UP BOOK
DIFFERENTIAL OIL

Tighten the screws equally



Finish tightening in this order

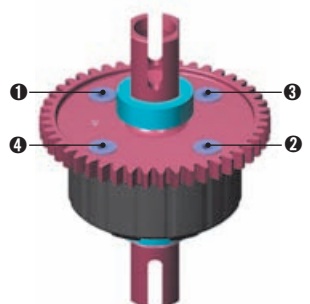

After assembly the differential should have a length of 32.3~32.5 mm measured from the ends of the installed ball-bearings. If differential is longer, retighten the 4 screws holding the spur gear.

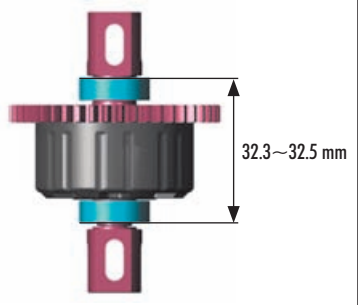

2. FRONT TRANSMISSION

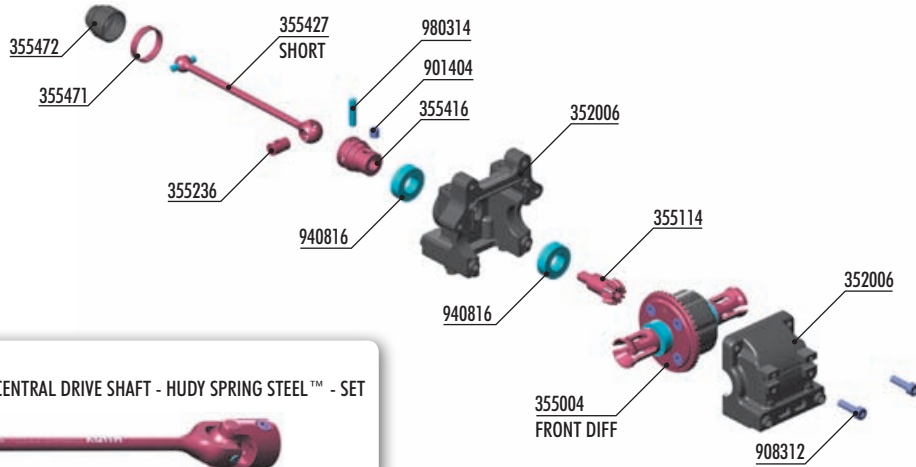

BAG

02

352006	XB8 DIFF BULKHEAD BLOCK SET FRONT/REAR	355472	DRIVE SHAFT BOOT (2)
355004	XB8 FRONT DIFFERENTIAL 46T - V2 - SET	901404	HEX SCREW SB M4x4 (10)
355114	BEVEL DRIVE GEAR 14T	908312	HEX SCREW SOCKET HEAD CAP SCH M3x12 (10)
355236	CVD DRIVE SHAFT COUPLING - HUDY SPRING STEEL™	940816	BALL-BEARING 8x16x5 RUBBER SEALED - GREASE (2)
355416	CENTRAL CVD SHAFT UNIVERSAL JOINT - HUDY SPRING STEEL™	980314	PIN 3x14 (10)
355427	FRONT CENTRAL CVD DRIVE SHAFT - HUDY SPRING STEEL™		
355471	DRIVE SHAFT LOCKING RING (2)		

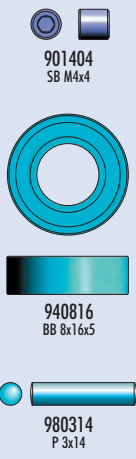

step 1

SHORT CVD DRIVE SHAFT

OIL Apply oil from inside to prevent breakage of the rubber boot.

GR Graphite Grease (HUDY #106210)

The ring can be assembled by hand, but for easy disassembly we recommend using snap ring pliers (HUDY #189040)

NOTE ORIENTATION

STEP 4 DETAIL

TL **PIN**

TOP

step 2

TIP Follow the TECH TIP on page 5 for drive shaft pin servicing

TL

Push joint against gear to remove gap. Tighten setscrew onto gear flat spot.

STEP 5 DETAIL

GR Use HUDY Ball-Bearing Grease
 #106220 - STANDARD
 #106221 - BLUE
 #106222 - RED

BEFORE inserting the clip on the central CVD shaft joint, apply a small amount of threadlock on the area where the clip goes.

AFTER inserting the clip on the central CVD shaft joint, turn the clip so that the slot is 90° from the pin. This will prevent the pin from opening the clip.



step 3

FRONT DIFF 6 000 cSt

GR Graphite Grease (HUDY #106210)

DETAIL Cut on both front and rear bulkhead blocks

2. REAR TRANSMISSION

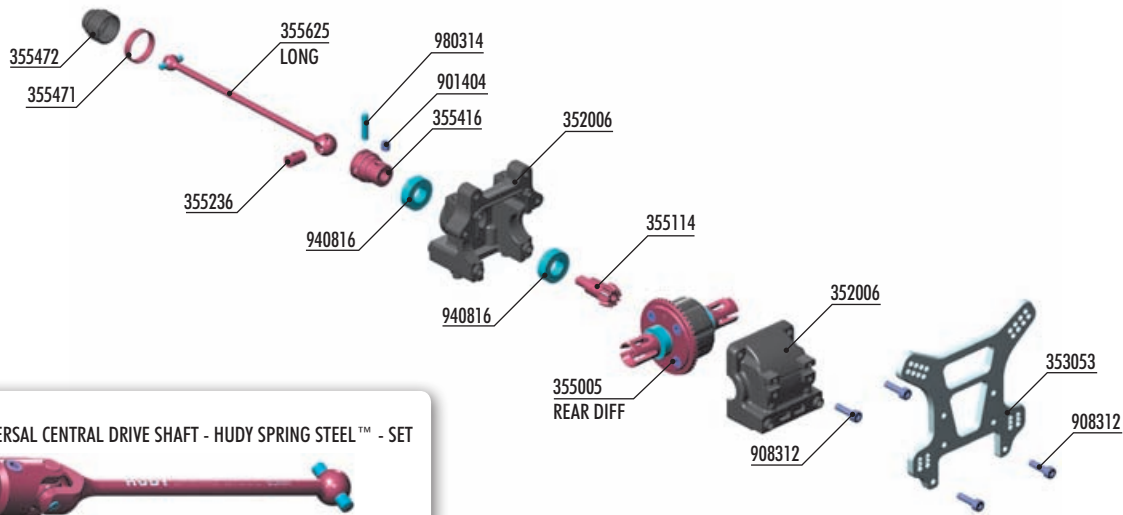

#355626
REAR UNIVERSAL CENTRAL DRIVE SHAFT - HUDY SPRING STEEL™ - SET
 OPTION



BAG

02

352006	XB8 DIFF BULKHEAD BLOCK SET FRONT/REAR	355471	DRIVE SHAFT LOCKING RING (2)
355005	XB8 REAR DIFFERENTIAL 46T - V2 - SET	355472	DRIVE SHAFT BOOT (2)
353053	XB8 ALU REAR SHOCK TOWER - CNC MACHINED 7075 T6 (4MM)	901404	HEX SCREW SB M4x4 (10)
355114	BEVEL DRIVE GEAR 14T	908312	HEX SCREW SOCKET HEAD CAP SCH M3x12 (10)
355236	CVD DRIVE SHAFT COUPLING - HUDY SPRING STEEL™	940816	BALL-BEARING 8x16x5 RUBBER SEALED - GREASE (2)
355416	CENTRAL CVD SHAFT UNIVERSAL JOINT - HUDY SPRING STEEL™	980314	PIN 3x14 (10)
355625	REAR CENTRAL CVD DRIVE SHAFT - HUDY SPRING STEEL™		



901404
SB M4x4

940816
BB 8x16x5

980314
P 3x14

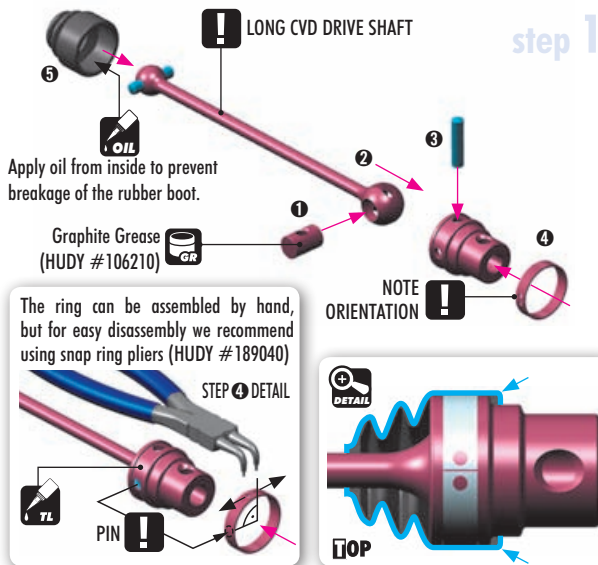

BEFORE inserting the clip on the central CVD shaft joint, apply a small amount of threadlock on the area where the clip goes.

AFTER inserting the clip on the central CVD shaft joint, turn the clip so that the slot is 90° from the pin. This will prevent the pin from opening the clip.

step 1

step 2

TIP Follow the TECH TIP on page 5 for drive shaft pin servicing.

Push joint against gear to remove gap. Tighten setscrew onto gear flat spot.

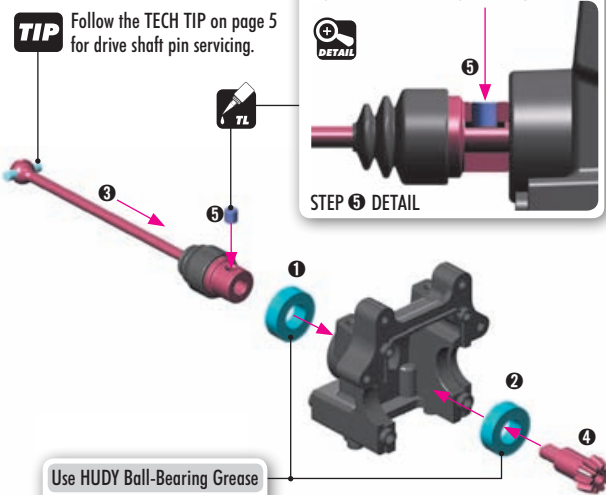

Use HUDY Ball-Bearing Grease
 #106220 - STANDARD
 #106221 - BLUE
 #106222 - RED

step 3

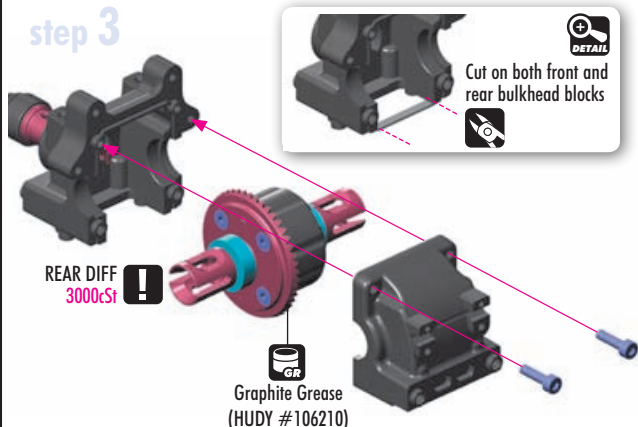

step 4

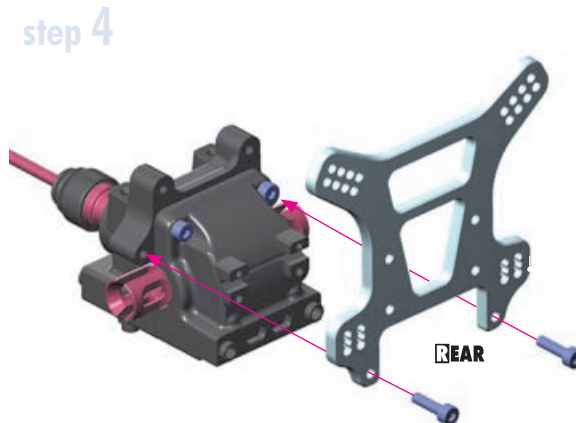

3. REAR SUSPENSION



- #353113 XB8'16 COMPOSITE REAR LOWER SUSPENSION ARM - RIGHT
- #353123 XB8'16 COMPOSITE REAR LOWER SUSPENSION ARM - LEFT
- #353317 XB8 ALU REAR LOWER SUSP. HOLDER - FRONT - SQUARE ADJ. ROLL CENTER
- #353325 XB8 ALU REAR LOWER SUSP. HOLDER - REAR - SQUARE ADJ. ROLL CENTER



REAR SUSPENSION ARMS

OPTION	REAR SUSPENSION ARMS	STATUS
#353115	MEDIUM	OPTION
#353116	HARD	OPTION
#353116-XH	X-HARD	INCLUDED
#353116-G	GRAPHITE	OPTION

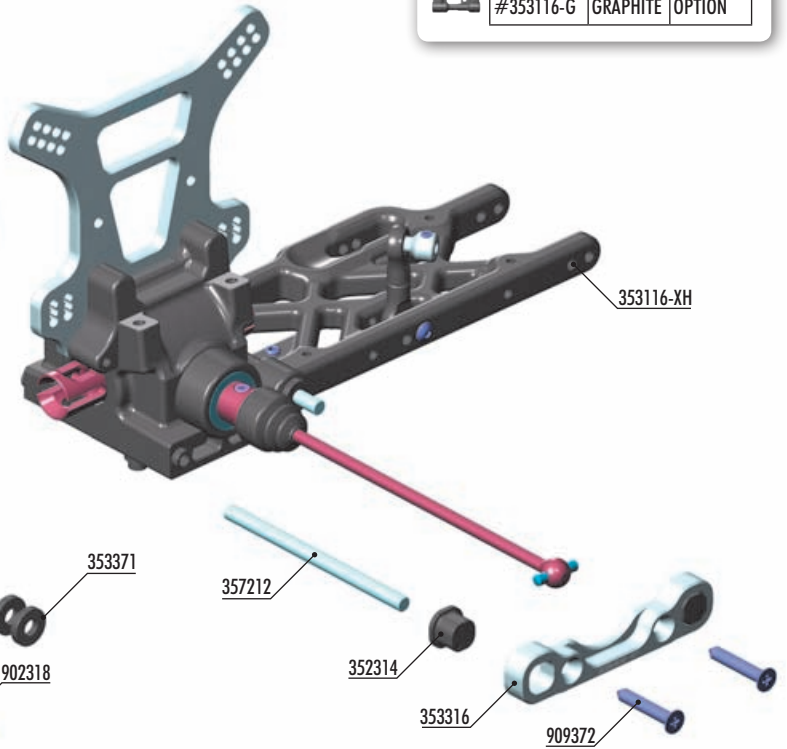
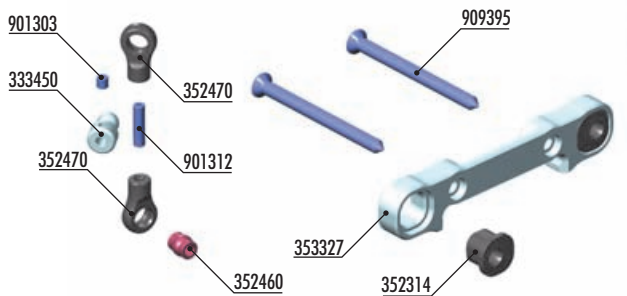
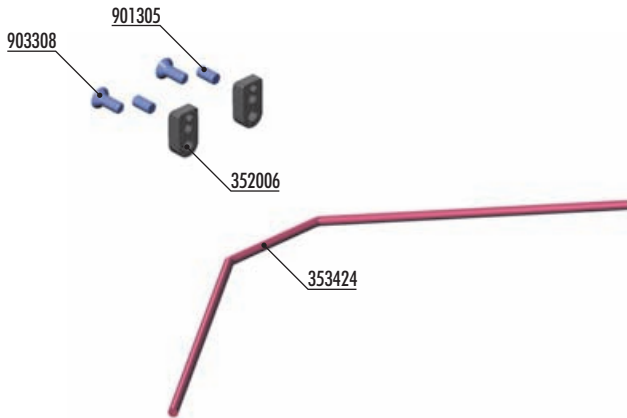

- #902407 HEX SCREW SH M4x7 WITH HEX FROM BOTTOM (4)



- #333451 ALU ANTI-ROLL BAR PIVOT BALL 5.8 MM - SWISS 7075 T6 - HARDCOATED (2)



REAR ANTI-ROLL BARS

OPTION	REAR ANTI-ROLL BARS	STATUS
#353418	ø1.8mm	OPTION
#353420	ø2.0mm	OPTION
#353422	ø2.2mm	OPTION
#353424	ø2.4mm	INCLUDED
#353425	ø2.5mm	OPTION
#353426	ø2.6mm	OPTION
#353428	ø2.8mm	OPTION
#353430	ø3.0mm	OPTION
#353432	ø3.2mm	OPTION

BAG

03

- 333450 ANTI-ROLL BAR BALL JOINT 5.8 MM (2)
- 352006 XB8 DIFF BULKHEAD BLOCK SET FRONT/REAR
- 352314 COMPOSITE ECCENTRIC BUSHINGS - V2 (2)
- 352460 PIVOT BALL 5.8 (10)
- 352470 BALL JOINT 5.8 (8)
- 353116-XH COMPOSITE REAR LOWER SUSPENSION ARM - X-HARD
- 353316 ALU REAR LOWER SUSP. HOLDER - FRONT - SQUARE ADJ. ROLL CENTER
- 353327 ALU REAR LOWER SUSP. HOLDER - REAR - SQUARE ADJ. ROLL CENTER
- 353371 SET OF COMPOSITE LOWER ARM SHIMS
- 353424 REAR ANTI-ROLL BAR 2.4MM
- 357212 LOWER INNER PIVOT PIN F+R (2)

- 901303 HEX SCREW SB M3x3 (10)
- 901305 HEX SCREW SB M3x5 (10)
- 901312 HEX SCREW SB M3x12 (10)
- 901408 HEX SCREW SB M4x8 (10)
- 902318 HEX SCREW SH M3x18 (10)
- 903308 HEX SCREW SFH M3x8 (10)
- 909372 SCREW PHILLIPS SS 3.5x22 (10)
- 909395 SCREW PHILLIPS SS 3.5x45 (10)

3. REAR SUSPENSION

901312
SB M3x12

2x L-R

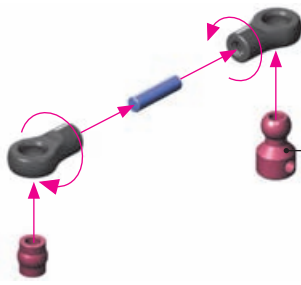

TIP Install the pivot balls with Professional Multi Tool (HUDY #183011)

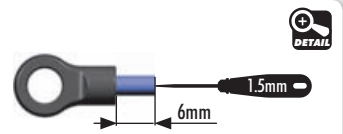

901303
SB M3x3

901305
SB M3x5

902318
SFH M3x18

903308
SFH M3x8

L-R

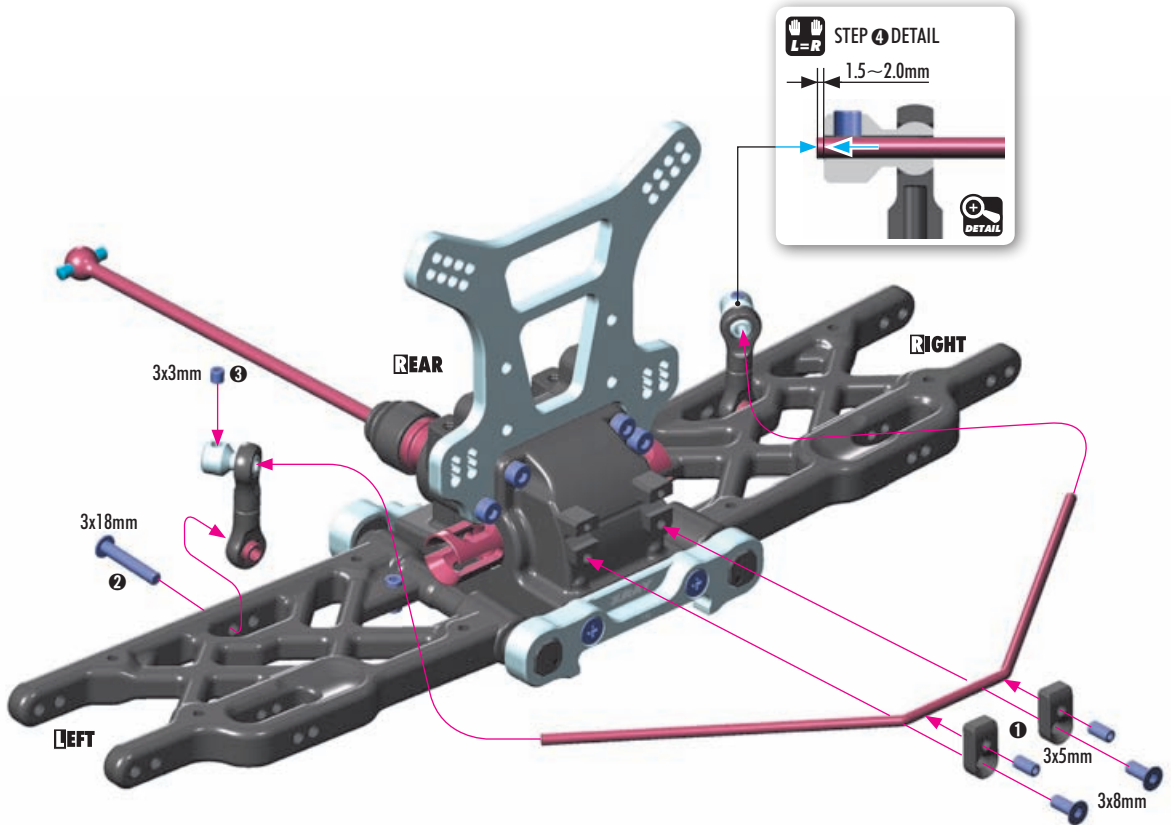

SET-UP BOOK
ANTI-ROLL BAR

INITIAL SETTING

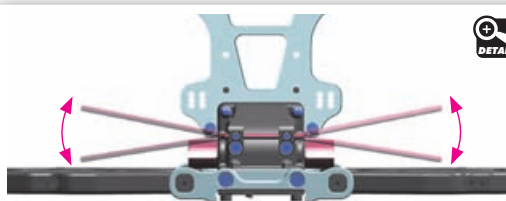

Step 1 check for free movement

Loosen the 3x5 setscrew if the anti-roll bar does not turn freely

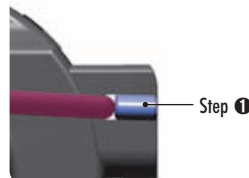

OPTION

REAR ANTI-ROLL BARS

OPTION	REAR ANTI-ROLL BARS	
#353418	ø1.8mm	OPTION
#353420	ø2.0mm	OPTION
#353422	ø2.2mm	OPTION
#353424	ø2.4mm	INCLUDED
#353425	ø2.5mm	OPTION
#353426	ø2.6mm	OPTION
#353428	ø2.8mm	OPTION
#353430	ø3.0mm	OPTION
#353432	ø3.2mm	OPTION

4. REAR SUSPENSION

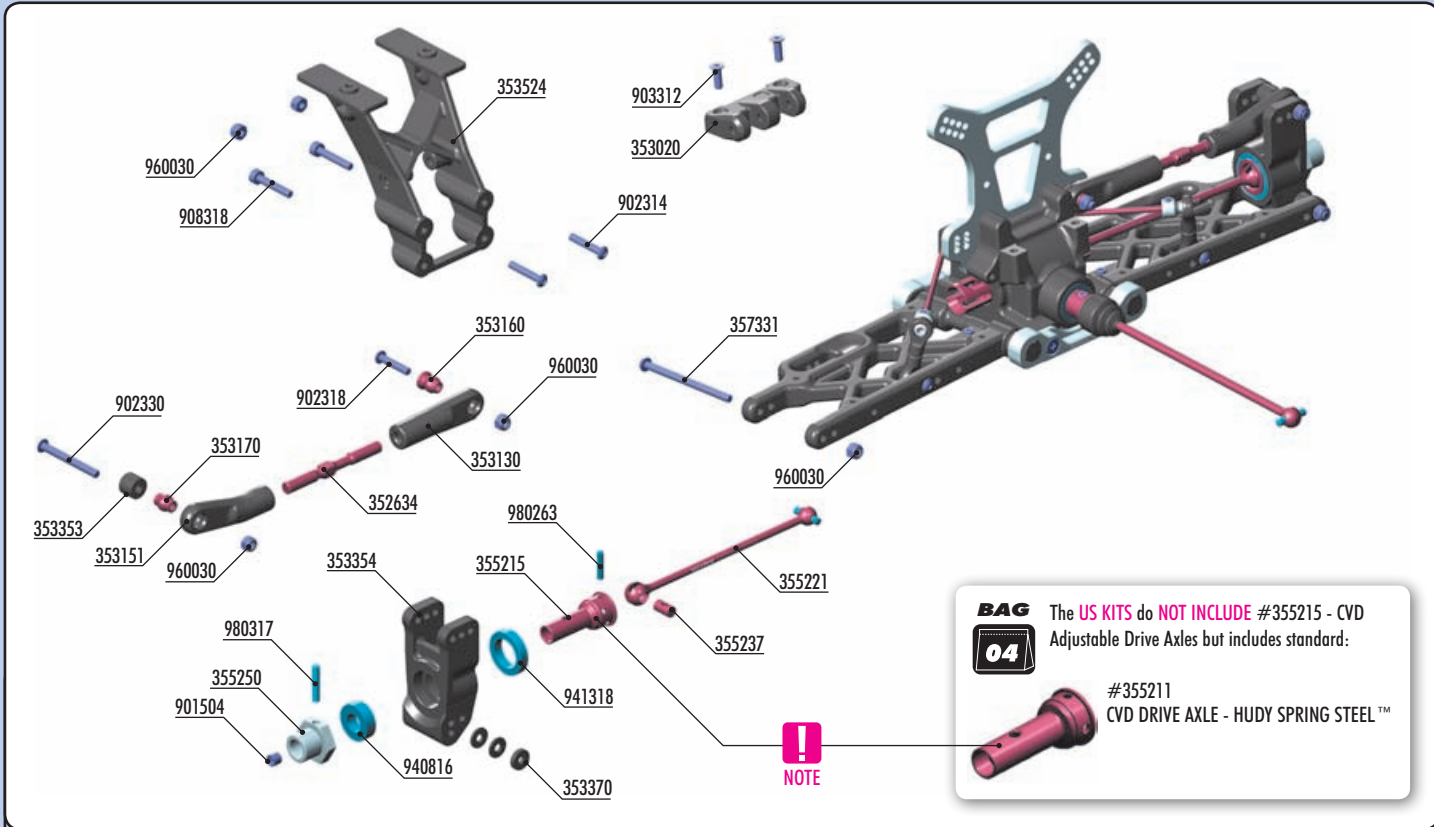

BAG
04

- 352634 ADJ. TURNBUCKLE M5 L/R 50 MM - HUDY SPRING STEEL™ (2)
- 353020 COMPOSITE REAR BRACE HOLDER
- 353130 REAR UPPER INNER CAMBER LINK BALL JOINT (2)
- 353151 RELIEF REAR UPPER OUTER CAMBER LINK BALL JOINT (2)
- 353160 MOUNTING BALL 6.8 (4)
- 353170 PIVOT BALL 6.8 (4)
- 353354 COMPOSITE REAR UPRIGHT
- 353370 SET OF COMPOSITE REAR HUB CARRIER SHIMS
- 353524 COMPOSITE REAR WING HOLDER
- 355215 CVD ADJUSTABLE DRIVE AXLE - HUDY SPRING STEEL™
- 355221 CVD UNIVERSAL DRIVE SHAFT - HUDY SPRING STEEL™
- 355237 CVD DRIVE SHAFT COUPLING - HUDY SPRING STEEL™
- 355250 ALU WHEEL AXLE - BLACK COATED (2)

- 357331 REAR LOWER OUTER PIVOT PIN SCREW 3MM (2)
- 901504 HEX SCREW SB M5x4 (10)
- 902314 HEX SCREW SH M3x14 (10)
- 902318 HEX SCREW SH M3x18 (10)
- 902330 HEX SCREW SH M3x30 (10)
- 903312 HEX SCREW SFH M3x12 (10)
- 908318 HEX SCREW SOCKET HEAD CAP SCH M3x18 (10)
- 940816 BALL-BEARING 8x16x5 RUBBER SEALED - GREASE (2)
- 941318 BALL-BEARING 13x19x4 RUBBER SEALED - GREASE (2)
- 960030 NUT M3 (10)
- 980263 PIN 2.5x13 (10)
- 980317 PIN 3x17 (10)

- 901504 SB M5x4
- 940816 BB 8x16x5
- 941318 BB 13x19x4
- 980263 P 2.5x13
- 980317 P 3x17

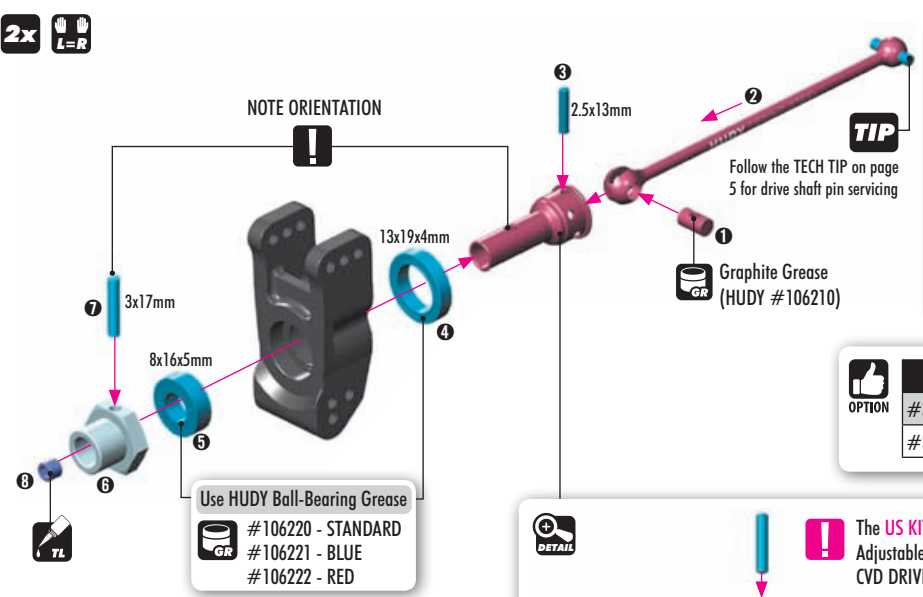

TIP To tighten the setscrew you can also use the HUDY 17mm Wheel Nut Tool #107570

REAR UPRIGHTS		
#353354	HARD	INCLUDED
#353354-G	GRAPHITE	OPTION

OFFSET WHEEL AXLES		
#355250	0mm	INCLUDED
#355251	+1mm	OPTION
#355252	+2mm	OPTION

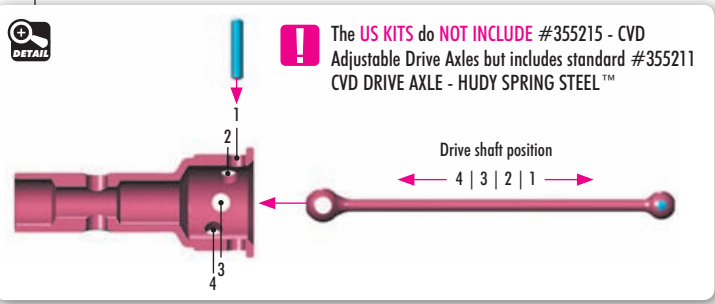

4. REAR SUSPENSION



353370
SHIM 3x9x1



353370
SHIM 3x9x2



960030
N M3

2x

TIP Ensure that the rear upright moves freely. If it does not move freely, use sandpaper to thin both wheelbase adjustment shims.

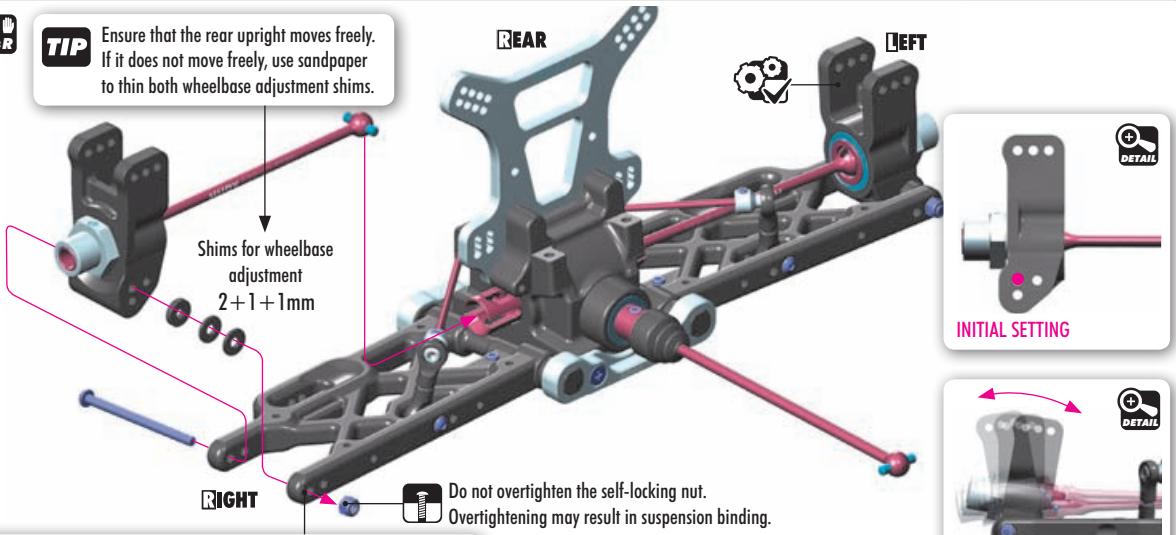

Do not overtighten the self-locking nut. Overtightening may result in suspension binding.

TIP

ARM REAMER (HUDY #107633)

If the rear upright does not move freely, use a HUDY Arm Reamer to resize the hole.

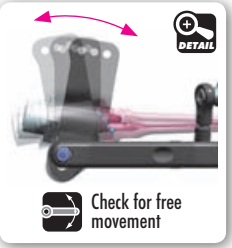
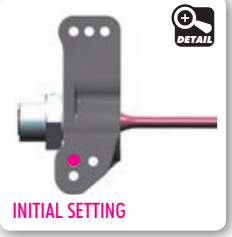

2x

TIP Install the pivot balls with Professional Multi Tool (HUDY #183011)

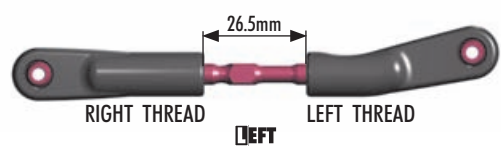
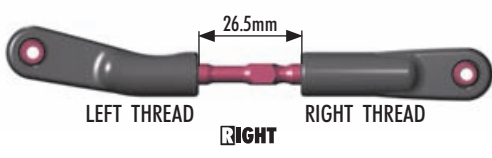
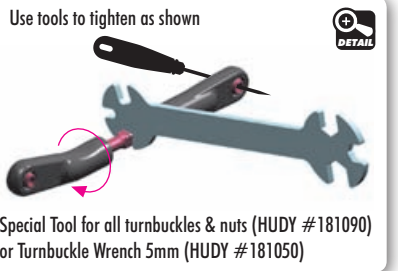
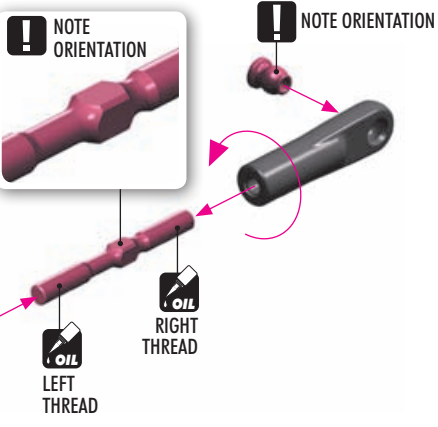

SET-UP BOOK
CAMBER

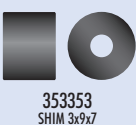

353353
SHIM 3x9x7

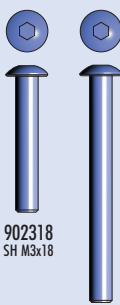

902318
SH M3x18

902330
SH M3x30



960030
N M3

2x

NOTE ORIENTATION

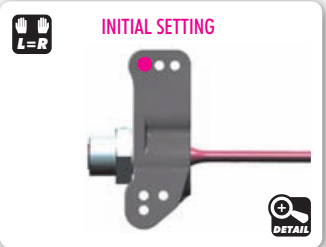
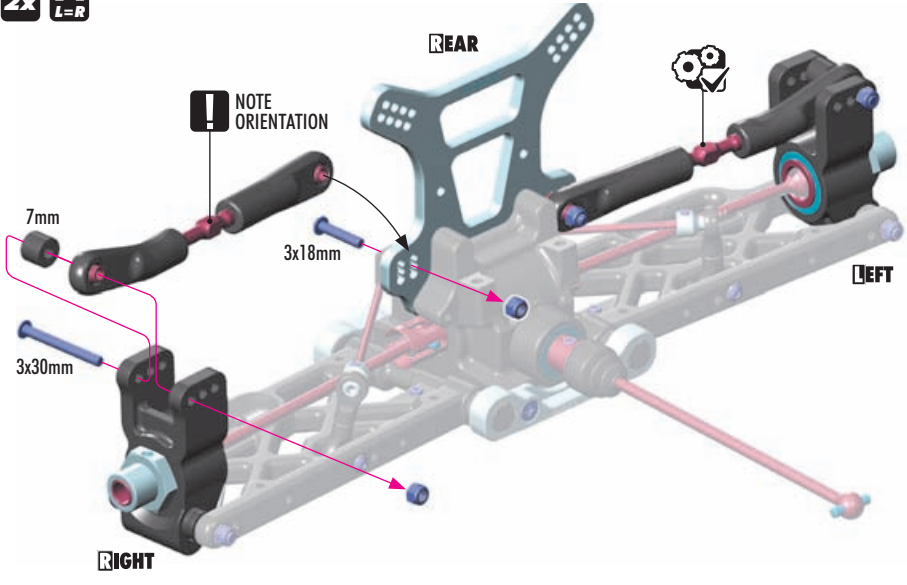

4. REAR SUSPENSION



903312
SFH M3x12

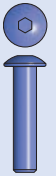
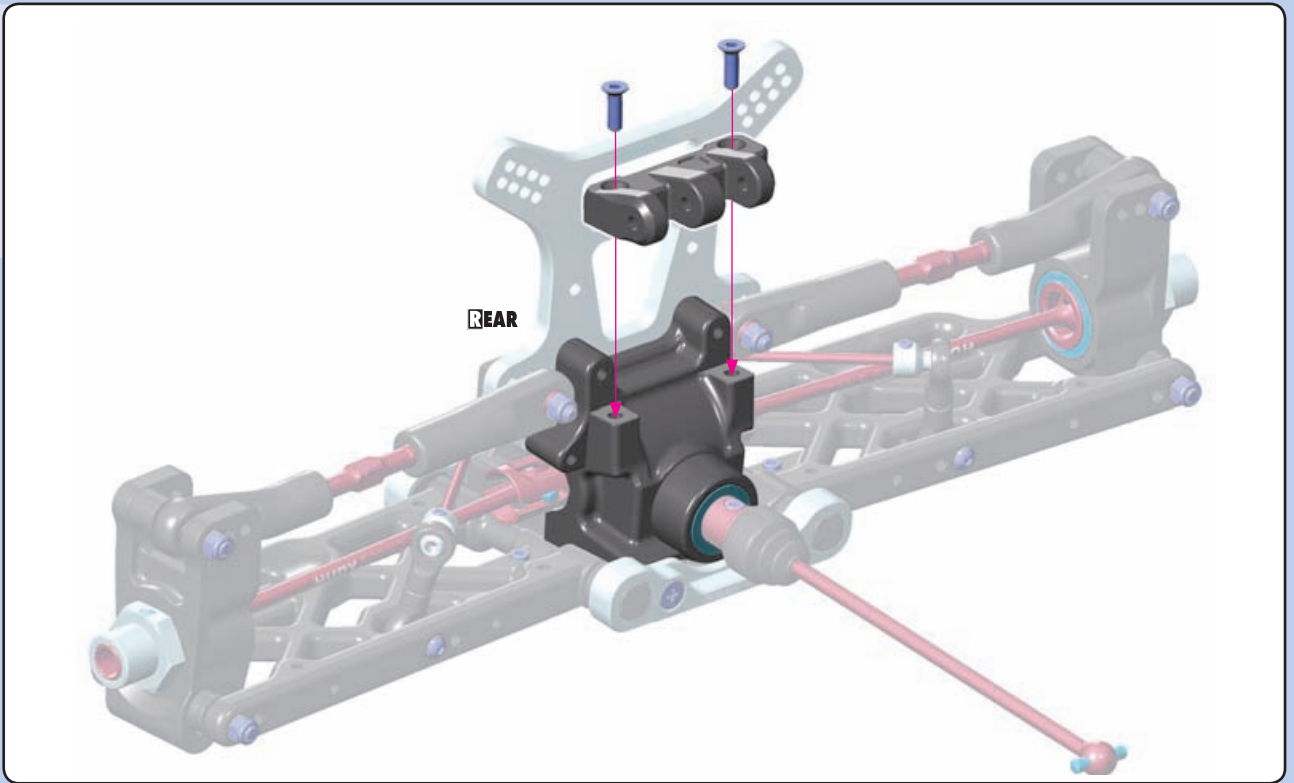

902314
SH M3x14



908318
SCH M3x18



960030
N M3

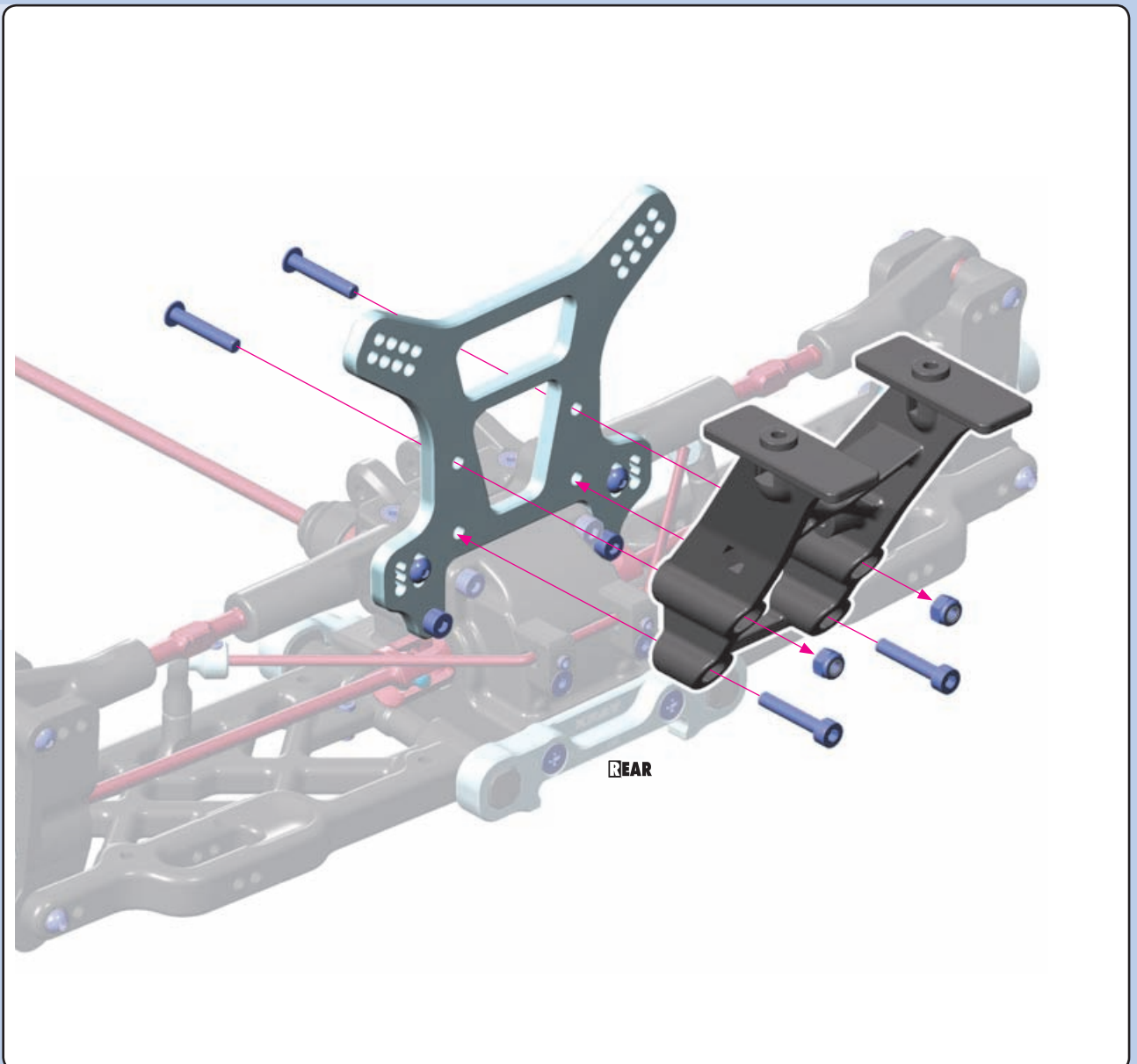

5. FRONT SUSPENSION



FRONT LOWER SUSP. ARMS

#352120	SOFT	OPTION
#352120-M	MEDIUM	INCLUDED
#352120-G	GRAPHITE	OPTION



909372

352324

352314



#902407
HEX SCREW SH M4x7 WITH HEX FROM BOTTOM (4)



357212

901408

353371

902318

352120-M

352314

352323

909395

901303

352492

352006

352470

333450

901305

901312

352470

352460



FRONT ANTI-ROLL BARS

#352487	1.6mm	OPTION
#352489	1.8mm	OPTION
#352490	2.0mm	OPTION
#352492	2.2mm	INCLUDED
#352493	2.3mm	OPTION
#352494	2.4mm	OPTION
#352495	2.5mm	OPTION
#352496	2.6mm	OPTION
#352498	2.8mm	OPTION



#333451
ALU ANTI-ROLL BAR PIVOT BALL 5.8 MM - SWISS 7075 T6 - HARDCOATED (2)



BAG

05

- 333450 ANTI-ROLL BAR BALL JOINT 5.8 MM (2)
- 352006 DIFF BULKHEAD BLOCK SET FRONT/REAR
- 352120-M COMPOSITE FRONT LOWER SUSPENSION ARM - MEDIUM
- 352323 ALU FRONT LOWER SUSP. HOLDER - FRONT - SQUARE ADJ. ROLL CENTER - V2
- 352324 ALU FRONT LOWER SUSP. HOLDER - REAR - SQUARE ADJ. ROLL CENTER - V2
- 352314 COMPOSITE SQUARE ADJ. ROLL CENTER BUSHINGS - V2 (2)
- 352460 PIVOT BALL 5.8 (10)
- 352470 BALL JOINT 5.8 (8)
- 352492 FRONT ANTI-ROLL BAR 2.4MM
- 353371 SET OF COMPOSITE LOWER ARM SHIMS

- 357212 LOWER INNER PIVOT PIN F + R (2)
- 901303 HEX SCREW SB M3x3 (10)
- 901305 HEX SCREW SB M3x5 (10)
- 901312 HEX SCREW SB M3x12 (10)
- 901408 HEX SCREW SB M4x8 (10)
- 902318 HEX SCREW SH M3x18 (10)
- 903308 HEX SCREW SFH M3x8 (10)
- 909372 SCREW PHILLIPS SS 3.5x22 (10)
- 909395 SCREW PHILLIPS SS 3.5x45 (10)

5. FRONT SUSPENSION



353371
SHIM 4x10x2



901408
SB M4x8



909372
SS 3.5x22



909395
SS 3.5x45

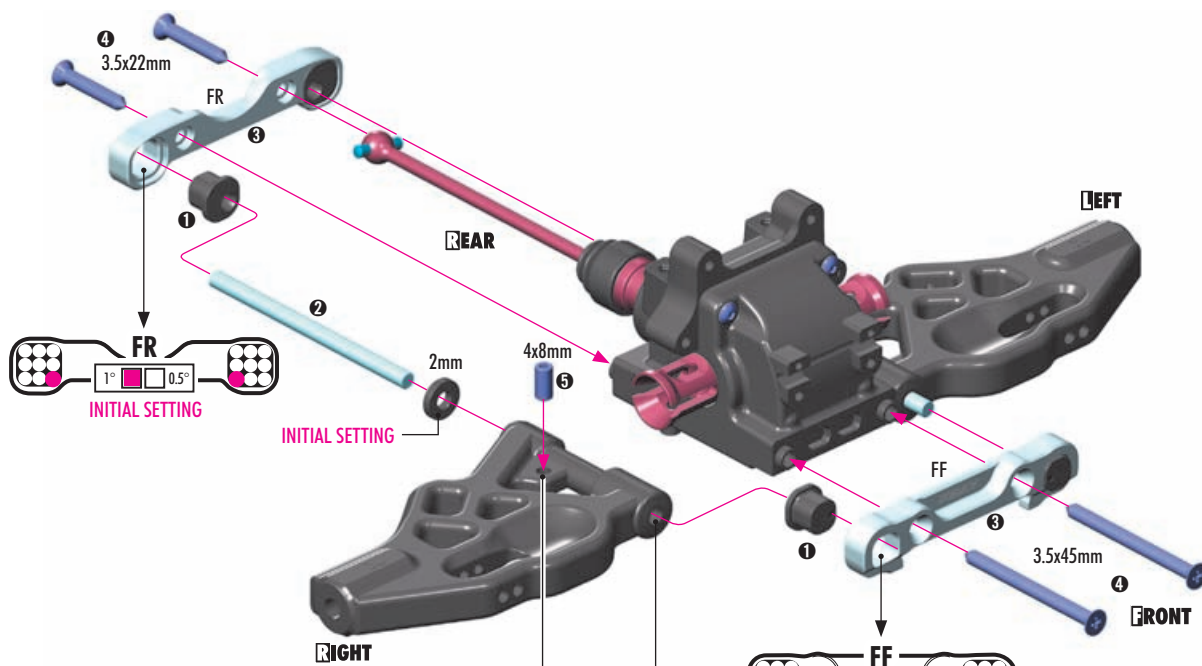

TOP DOWNSTOP SETTING

BOTTOM 0.0mm

#902407
OPTION

Downstop screw for fine tuning.

TIP L=R

If the suspension arms do not move freely, use a HUDY Arm Reamer to resize the holes.

(HUDY #107634)
ARM REAMER

All possible mounting alternatives of eccentric bushings

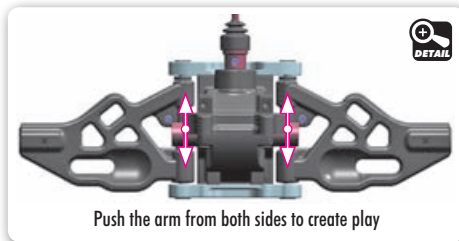
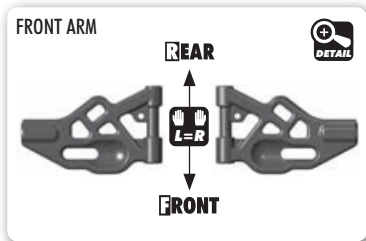

Eccentric bushings have two different offsets from the center.

- Middle position = 0.5 mm or 0.5° from center
- Outer position = 1 mm or 1° from center

The XRAY alu front lower suspension holders provide even greater range of adjustment for the front suspension. Using different combinations of eccentric bushings, fine adjustment of front kick-up, roll center, and front track-width can be obtained. For more information about the influence of kick-up, front track-width, and roll centers on car handling, please refer to HUDY Off-Road Set-up Book (#209099).

TRACK-WIDTH			(mm)
FF	FR		
			=308
			=306
			=310*

ROLL CENTER			(mm)
FF	FR		
			=1
			=0
			=-1

The tables below describe the amounts of kick-up, front track-width change depending on the combinations of eccentric bushings used with 0 and 1mm, 1° offset. The 0.5mm, 0.5° represents the half change.

* Not recommended to use this setting.

SET-UP BOOK
KICK UP
ROLL CENTER DOWNSTOP
WHEELBASE
TRACK WIDTH

5. FRONT SUSPENSION



901312
SB M3x12

2x L=R

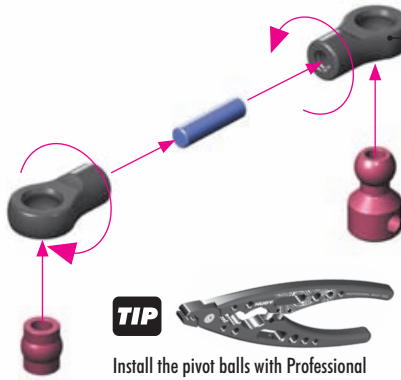

TIP

Install the pivot balls with Professional Multi Tool (HUDY #183011)

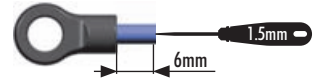

901303
SB M3x3



901305
SB M3x5



902318
SH M3x18



903308
SFH M3x8

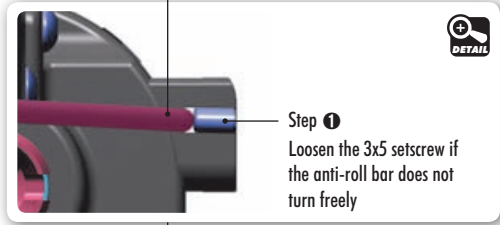
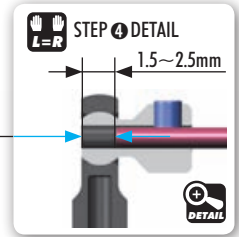
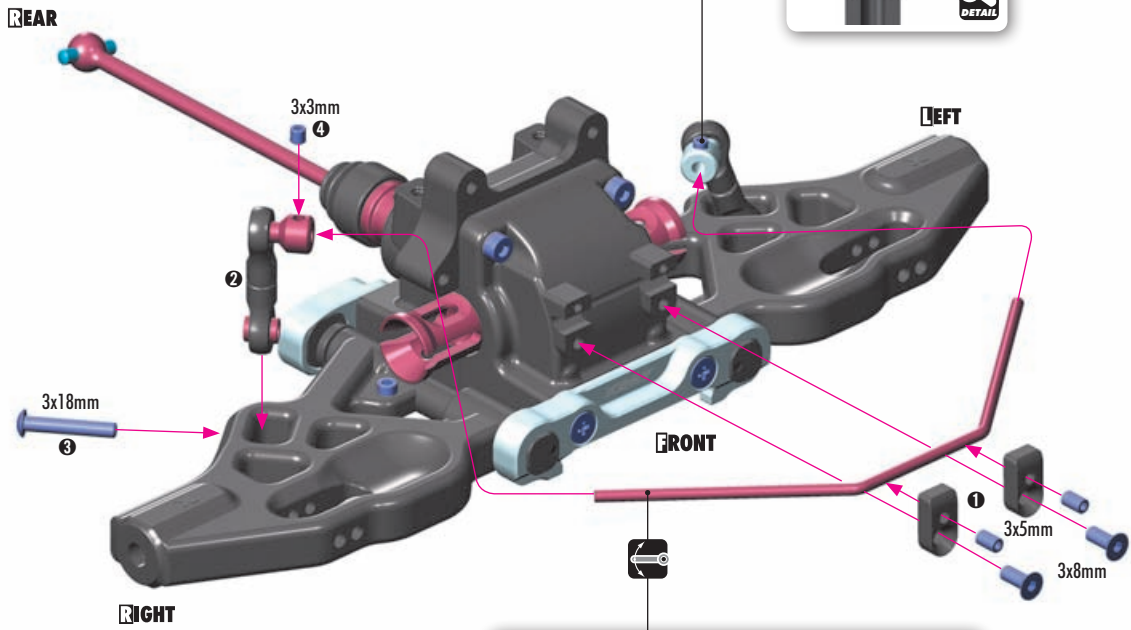

Step 1
Loosen the 3x5 setscrew if the anti-roll bar does not turn freely

FRONT ANTI-ROLL BARS			
OPTION	#352487	1.6mm	OPTION
}	#352489	1.8mm	OPTION
	#352490	2.0mm	OPTION
	#352492	2.2mm	INCLUDED
	#352493	2.3mm	OPTION
	#352494	2.4mm	OPTION
	#352495	2.5mm	OPTION
	#352496	2.6mm	OPTION
	#352498	2.8mm	OPTION

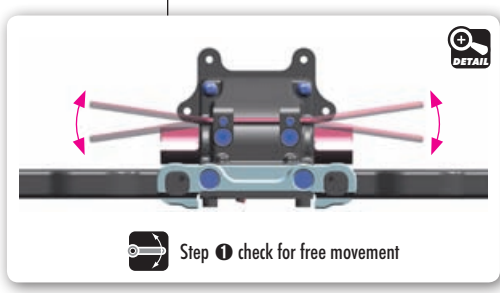

Step 1 check for free movement

SET-UP BOOK
ANTI-ROLL BAR

6. FRONT SUSPENSION



FRONT UPPER SUSP. ARMS

#352133	SOFT	OPTION
#352133-M	MEDIUM	INCLUDED
#352133-G	GRAPHITE	OPTION



OFFSET WHEEL AXLES

#355250	0mm	OPTION
#355251	+1mm	INCLUDED
#355252	+2mm	OPTION



STEERING BLOCKS

#352244	HARD	INCLUDED
#352244-G	GRAPHITE	OPTION

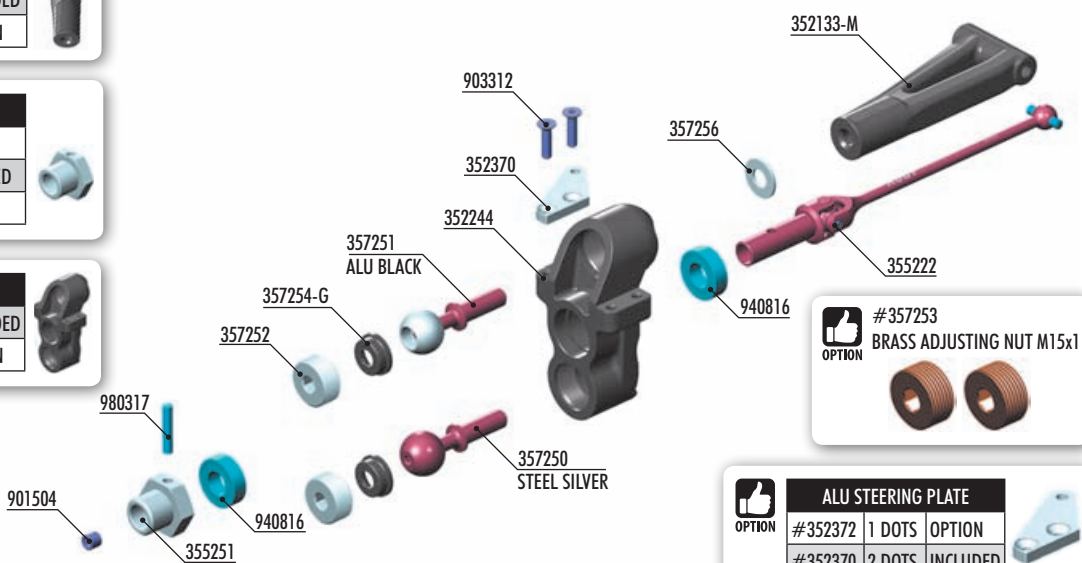

BAG



- 352133-M FRONT UPPER ARM
- 352244 STEERING BLOCK
- 352370 ALU STEERING PLATE - SWISS 7075 T6 (L+R)
- 355222 UNIVERSAL DRIVE SHAFT - HUDY SPRING STEEL™
- 355251 ALU WHEEL AXLE OFFSET "+1MM" - HARD COATED (2)
- 357250 STEEL PIVOT BALL 13.7 MM (2)
- 357251 ALU PIVOT BALL 13.7 MM WITH STEEL SCREW (2)
- 357252 ALU ADJUSTING NUT M15x1 (2)
- 357254-G COMPOSITE BALL CUP 13.9 MM - GRAPHITE (2)
- 357256 ALU SHIM 6x13x1 (2)
- 901504 HEX SCREW SB M5x4 (10)
- 903312 HEX SCREW SFH M3x12 (10)
- 940816 BALL-BEARING 8x16x5 RUBBER SEALED - GREASE (2)
- 980317 PIN 3x17 (10)



901504
SB M5x4



940816
BB 8x16x5

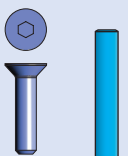

903312
SFH M3x12



980317
P 3x17

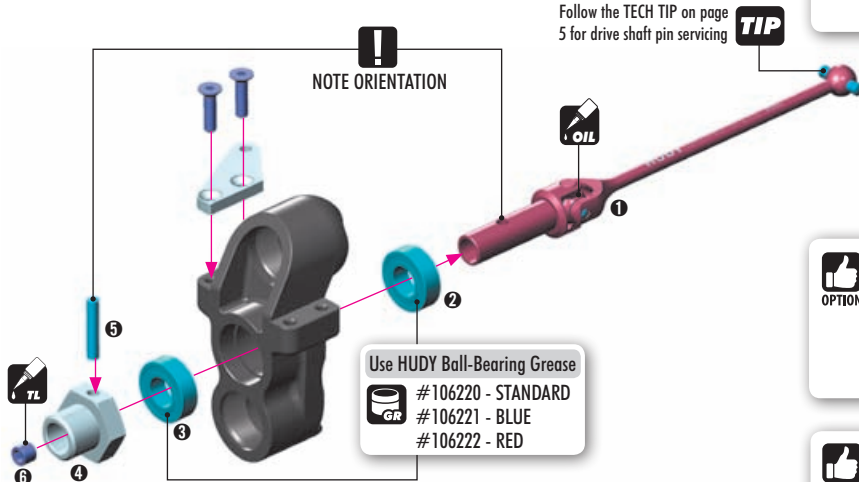

NOTE ORIENTATION

Follow the TECH TIP on page 5 for drive shaft pin servicing



Use HUDY Ball-Bearing Grease
 #106220 - STANDARD
 #106221 - BLUE
 #106222 - RED



FRONT UPPER SUSP. ARMS

#352133	SOFT	OPTION
#352133-M	MEDIUM	INCLUDED
#352133-G	GRAPHITE	OPTION



#357253
BRASS ADJUSTING NUT M15x1

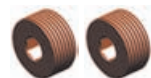

OFFSET WHEEL AXLES

#355250	0mm	OPTION
#355251	+1mm	INCLUDED
#355252	+2mm	OPTION



STEERING BLOCKS

#352244	HARD	INCLUDED
#352244-G	GRAPHITE	OPTION



To tighten the setscrew you can also use the (HUDY 17mm Wheel Nut Tool #107570)



ALU STEERING PLATE

#352372	1 DOTS	OPTION
#352370	2 DOTS	INCLUDED



- CVD DRIVE SHAFT
- BALL-BEARING



6. FRONT SUSPENSION



2x 

! ALU pivot ball
BLACK color

WD40

! STEEL pivot ball
SILVER color

TIP Tighten hex nuts using HUDY tool #107581

OPTION  #357253 Brass Adjusting Nut M15x1 

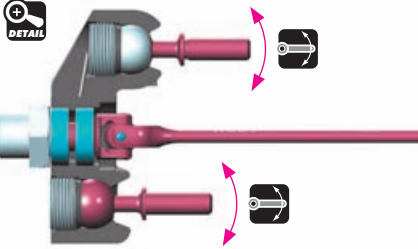
DETAIL 

PIVOT BALLS MUST MOVE FREELY
During initial assembly, tighten each hex nut until the pivot ball starts to bind, then loosen slightly. Verify that the pivot balls move freely.





357256
SHIM 6x13x1

2x 

TIP  HUDY Tool Allen 2.5mm

1mm 

OPTION 

FRONT UPPER SUSP. ARMS			
#352133	SOFT	OPTION	
#352133-M	MEDIUM	INCLUDED	
#352133-G	GRAPHITE	OPTION	

SET-UP BOOK
CAMBER
TRACK-WIDTH

2x 

TIP  HUDY Tool Allen 2.5mm

RIGHT

FRONT

LEFT 

SET-UP BOOK
ROLL CENTER

6. FRONT & REAR ASSEMBLY



902335
SH M3x35

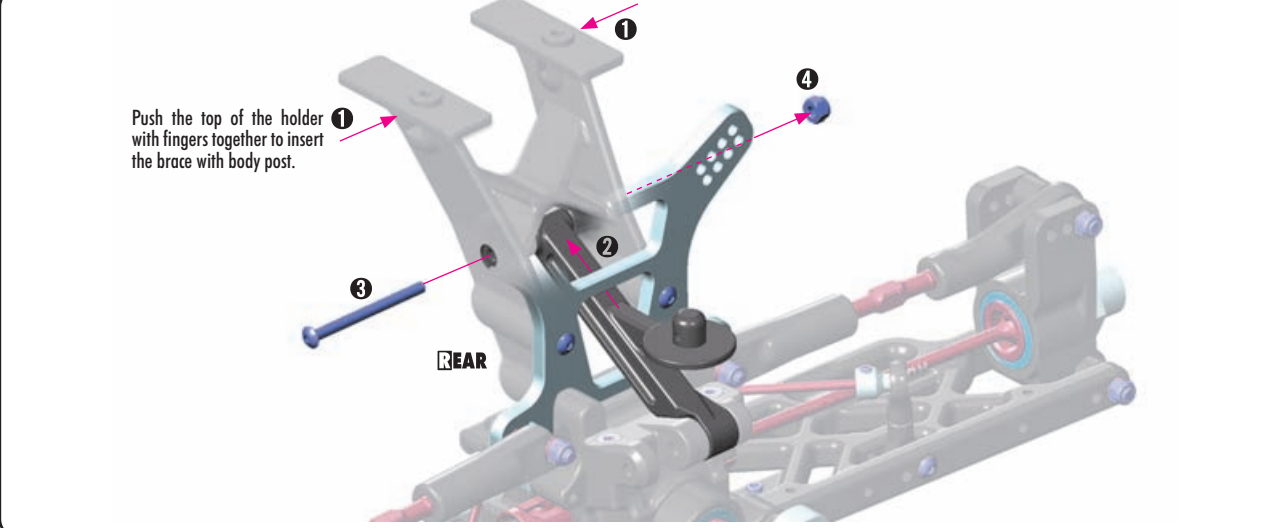

Push the top of the holder **1** with fingers together to insert the brace with body post.



960030
N M3



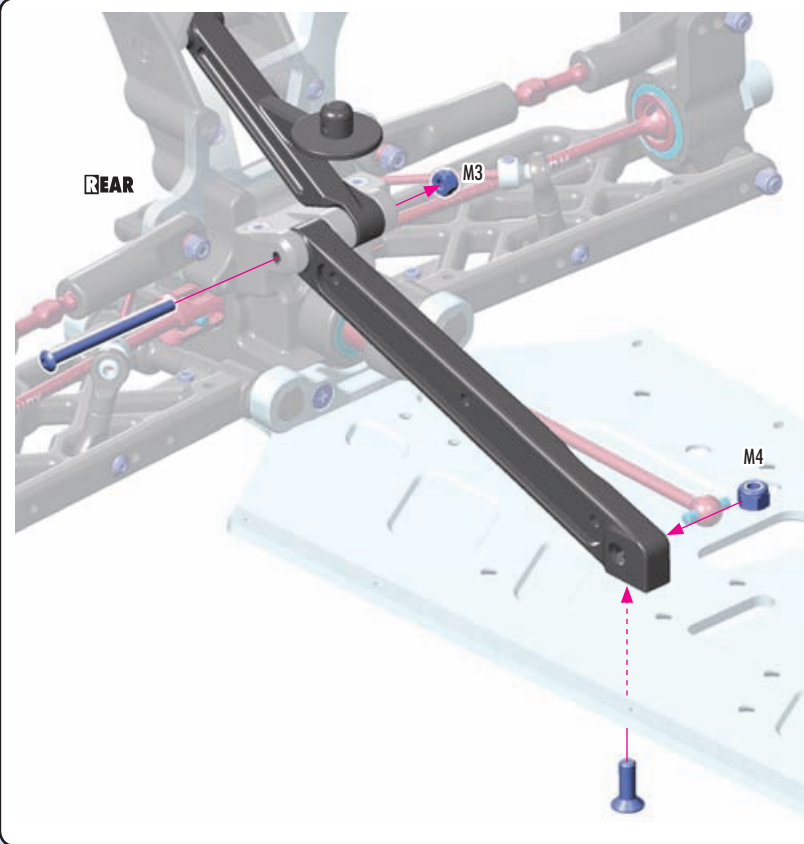

902340
SH M3x40





REAR

#353280
GRAPHITE BRACE SET for extra stiffness adjustment.
OPTION





903412
SFH M4x12

960030 N M3 960040 N M4

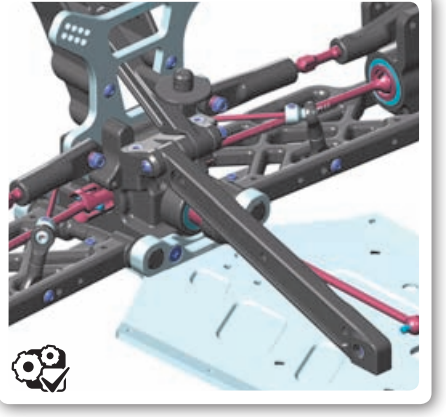

FRONT

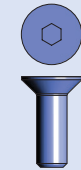

903412
SFH M4x12

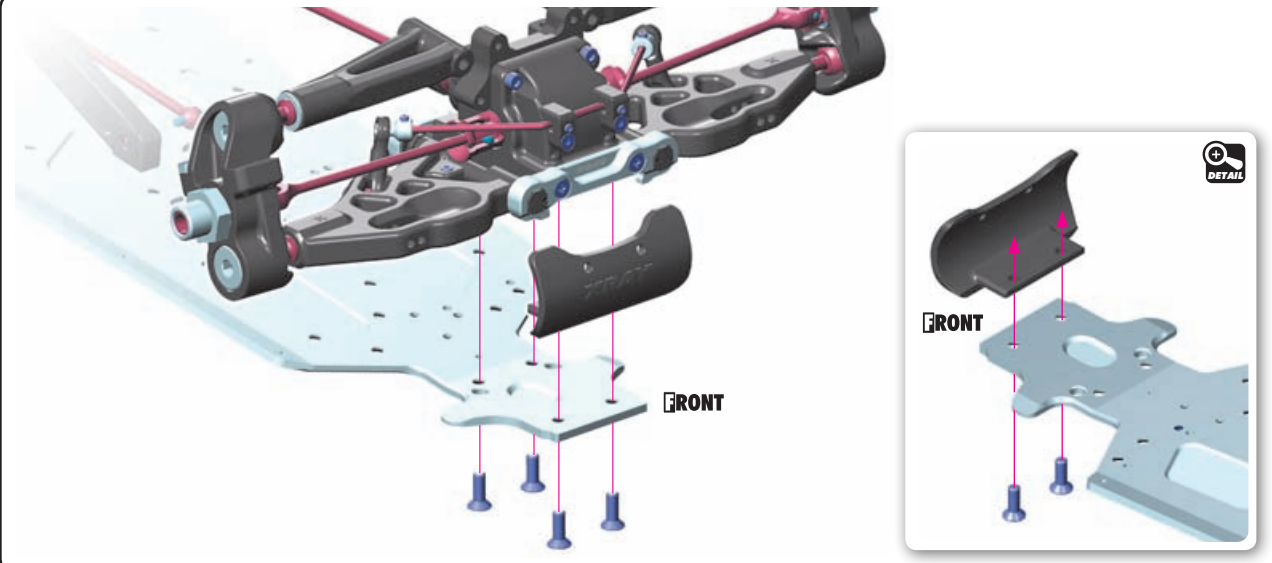

FRONT

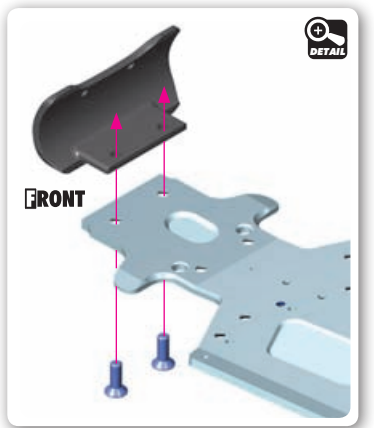

FRONT

DETAIL

7. STEERING

#351348
GRAPHITE UPPER PLATE
OPTION

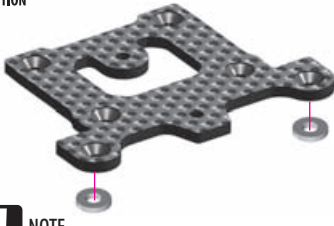

NOTE
Must be used also 2pcs of #303136 shim 3x7x1mm.

#352658
BALL STUD 6.8mm WITH BACKSTOP L=6mm - M3x8 (2)
OPTION

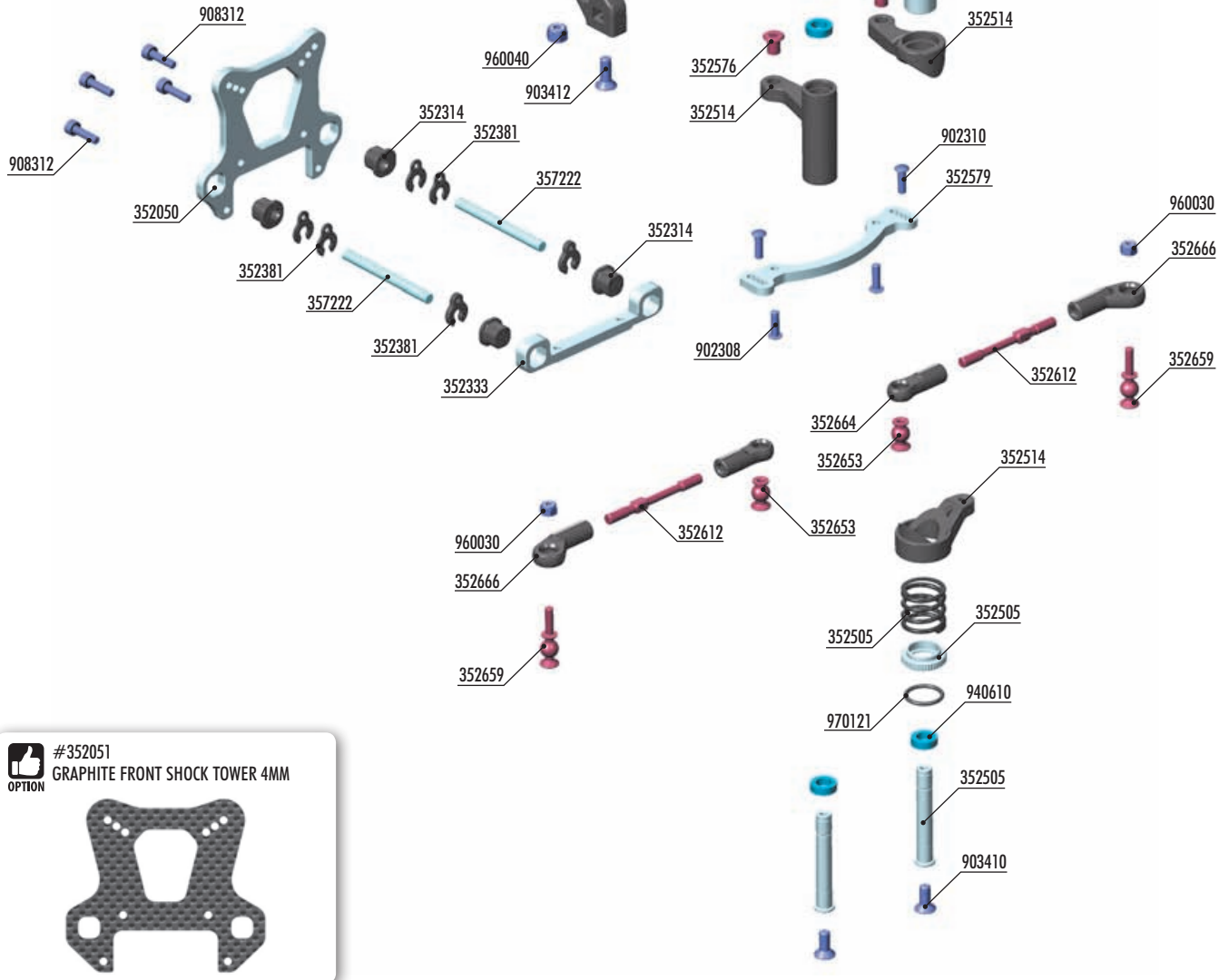
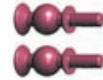

#352051
GRAPHITE FRONT SHOCK TOWER 4MM
OPTION



BAG
07

351301	BODY POSTS	357222	FRONT UPPER PIVOT PIN 4x45 (2)
351344	COMPOSITE UPPER PLATE	902308	HEX SCREW SH M3x8 (10)
352084	COMPOSITE FRONT BRACE	902310	HEX SCREW SH M3x10 (10)
352050	ALU FRONT SHOCK TOWER - CNC MACHINED 7075 T6 (4MM)	902312	HEX SCREW SH M3x12 (10)
352314	COMPOSITE SQUARE ADJ. ROLL CENTER BUSHINGS - V2 (2)	903308	HEX SCREW SFH M3x8 (10)
352333	ALU FRONT UPPER ARM HOLDER - SWISS 7075 T6 (6MM)	903310	HEX SCREW SFH M3x10 (10)
352381	CASTER CLIPS (2)	903312	HEX SCREW SFH M3x12 (10)
352505	SERVO SAVER COMPLETE SET - GRAPHITE	903410	HEX SCREW SFH M4x10 (10)
352514	COMPOSITE SERVO SAVER - GRAPHITE	903412	HEX SCREW SFH M4x12 (10)
352576	STEERING PLATE BUSHING (2)	908312	HEX SCREW SOCKET HEAD CAP SCH M3x12 (10)
352579	ALU STEERING PLATE - SWISS 7075 T6	940610	BALL-BEARING 6x10x3 RUBBER SEALED - OIL (2)
352612	ADJ. TURNBUCKLE M4 L/R 45 MM - HUDY SPRING STEEL™ (2)	960030	NUT M3 (10)
352653	BALL STUD 6.8MM WITH BACKSTOP - M3 (2)	960040	NUT M4 (10)
352659	BALL STUD 6.8MM WITH BACKSTOP L=6MM - M3x11 (2)	970121	O-RING 12.1 x 1.6 (10)
352664	COMPOSITE STEERING BALL JOINT 6.8MM - V3 (2)		
352666	COMPOSITE RELIEF STEERING BALL JOINT 6.8MM (2)		

7. STEERING



970121
0 12.1x1.6

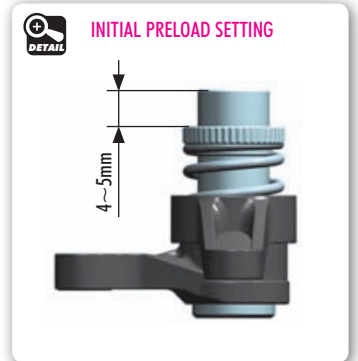
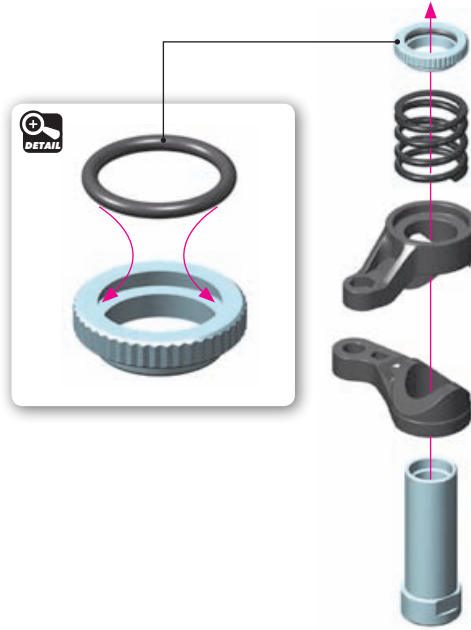

SET-UP BOOK
SERVO SAVER

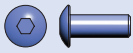

902308
SH M3x8

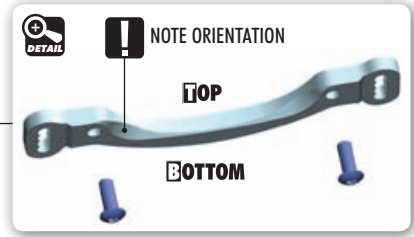
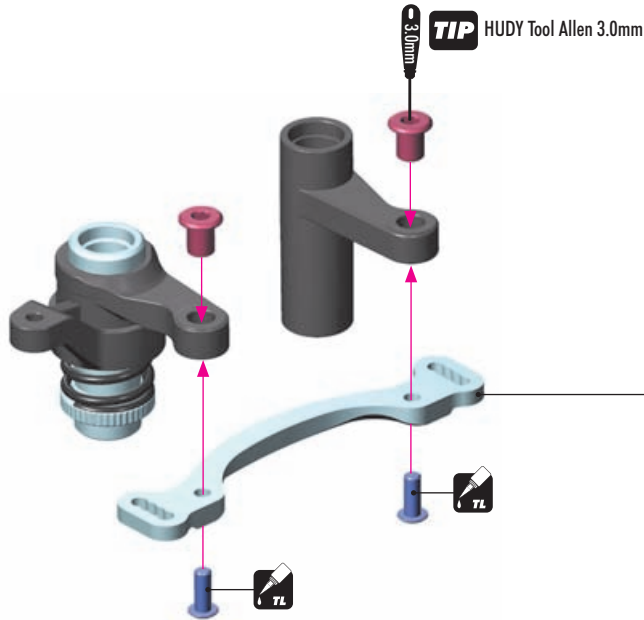

903410
SFH M4x10

940610
BB 6x10x3

For servicing use
Bearing Oil (HUDY #106230)

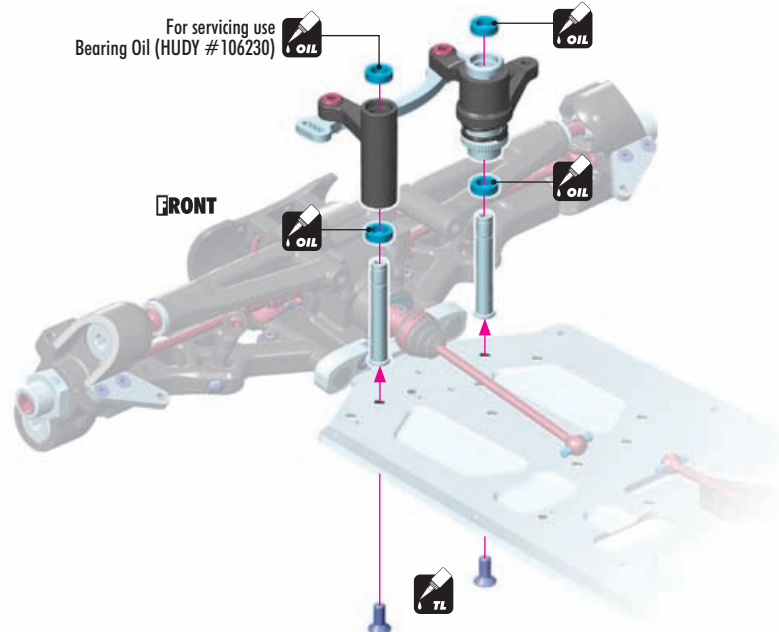



All possible mounting alternatives of eccentric bushings

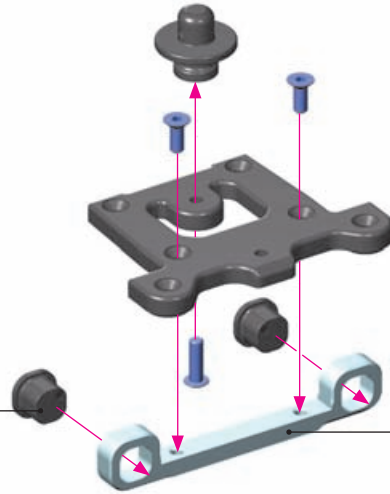
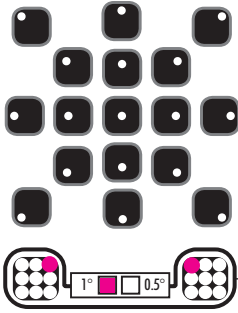

SET-UP BOOK
ROLL CENTER

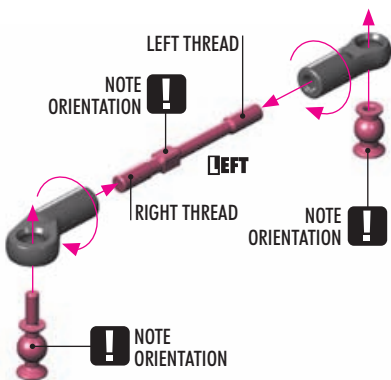
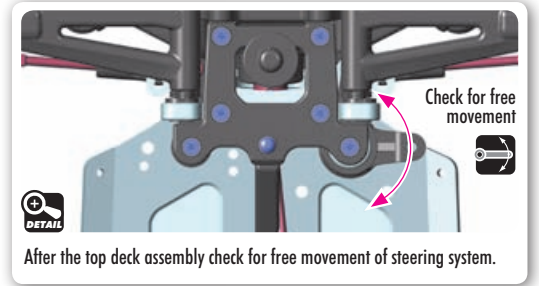
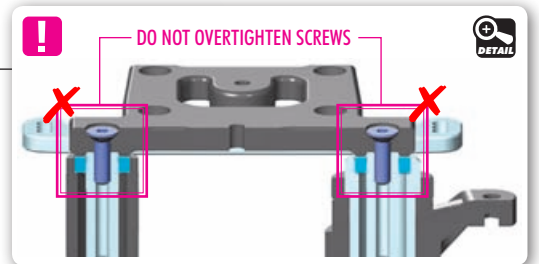
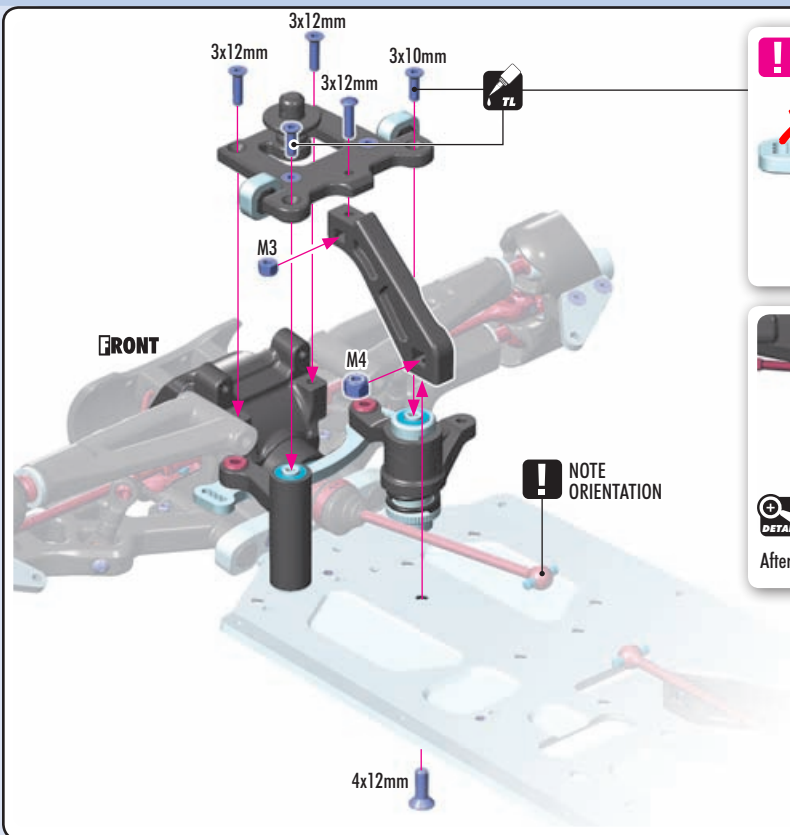
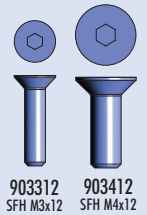
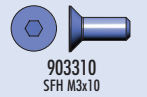

TIP Install the pivot balls with Professional Multi Tool (HUDY #183011)

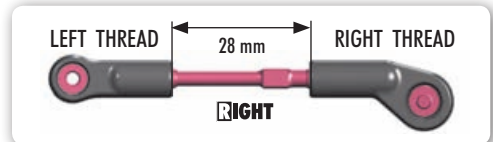
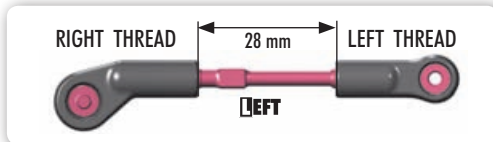
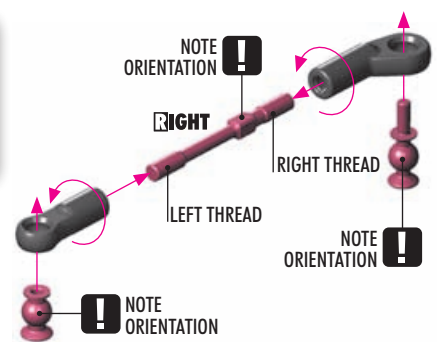

7. STEERING



908312
SCH M3x12

LEFT

RIGHT

FRONT

INITIAL SETTING

1.0mm

1.0mm

2.0mm

NOTE ORIENTATION

#352051
OPTION XB8 GRAPHITE FRONT SHOCK TOWER 4MM

UPPER CLIP
Behind arm

LOWER SHIM
Behind arm

CASTER

F=R

UPPER CLIP (Behind arm)	CASTER	
	LOWER SHIM (Behind arm) 4mm	LOWER SHIM (Behind arm) 2mm
4mm	24°	21°
3mm	25.5°	22.5°
2mm	27°	24°
1mm	28.5°	25.5°
0	30°	27°

All possible mounting alternatives of eccentric bushings

SET-UP BOOK
ROLL CENTER
CASTER



902310
SH M3x10



960030
N M3

2x **L=R**

FRONT

RIGHT

LEFT

INITIAL SETTING

NOTE ORIENTATION
Adjustment block towards outside

NOTE ORIENTATION
Adjustment block towards outside

Check for free movement

Check for free movement

SET-UP BOOK
ACKERMANN
BUMP STEER
TOE-IN

8. CENTER DIFF & BRAKE

#354057
GRAPHITE CENTER DIFF MOUNTING PLATE



! Must be used for 47T and 48T spur gear.

#354113
SUPER-LIGHTWEIGHT VENTILATED BRAKE DISK - PRECISION-GROUND (2)



#354112
LIGHTWEIGHT VENTILATED BRAKE DISK - LASER CUT - PRECISION-GROUND (2)



#354111
GRAPHITE VENTILATED BRAKE DISK - CNC MACHINED (2)

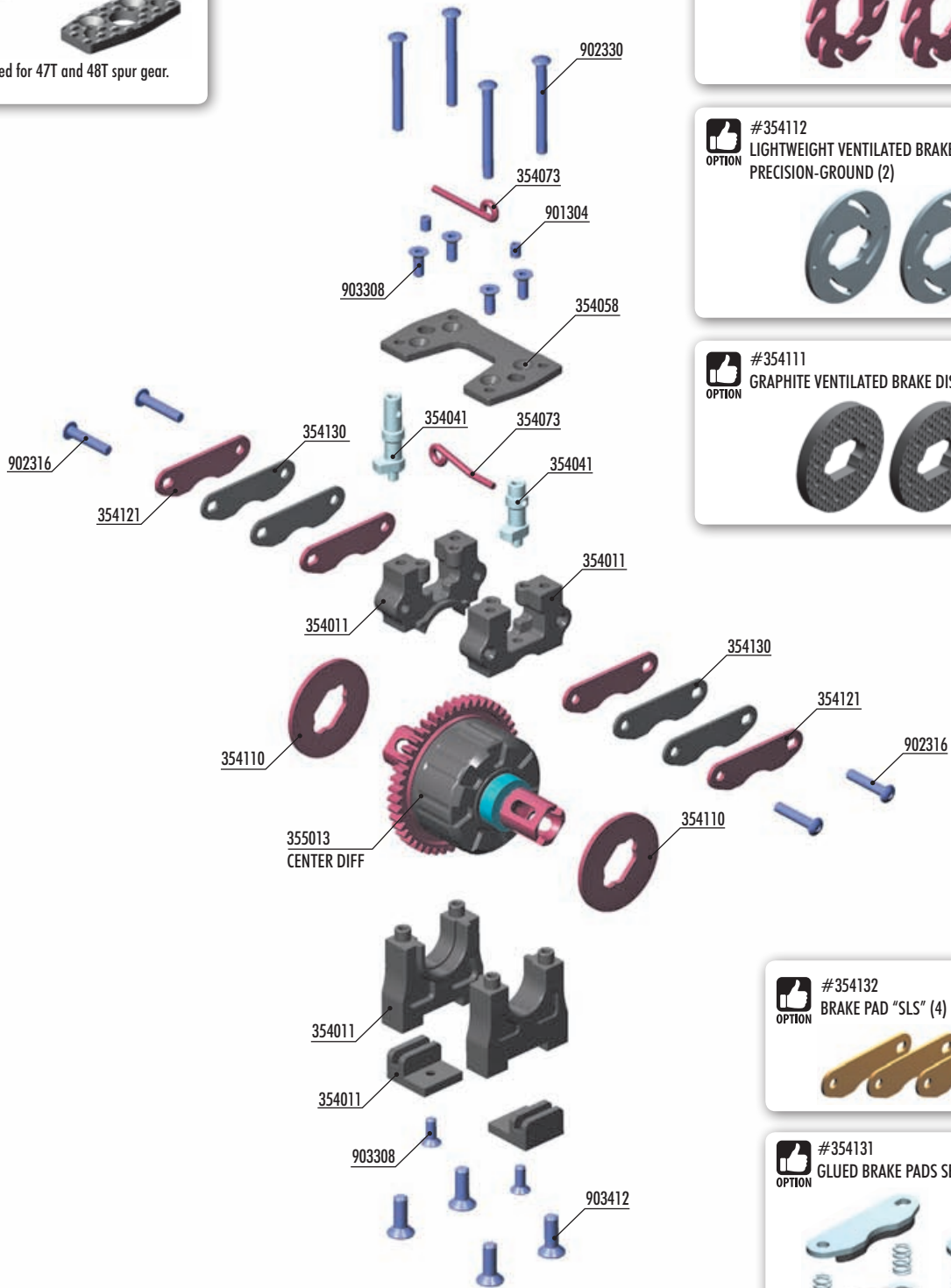

#354132
BRAKE PAD "SLS" (4)



#354131
GLUED BRAKE PADS SET-ULTRA EFFICIENT (4)

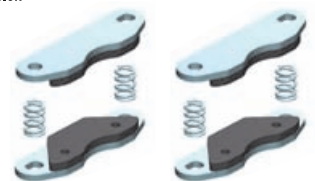

For improved brake efficiency and increased lifespan use the **OPTION** brake pads with springs.

BAG

08

- 354011 CENTER DIFF MOUNTING PLATE SET - HIGHER
- 354041 ALU BRAKE CAM POST & ROD (2+2) HARD COATED
- 354058 COMPOSITE CENTER DIFF MOUNTING PLATE
- 354073 BRAKE CAME ROD (1+1)
- 354110 VENTILATED BRAKE DISK - LASER CUT - PRECISION-GROUND
- 354121 STEEL BRAKE PAD - LASER CUT (4)
- 354130 BRAKE PAD FIBER (4)

- 355013 CENTER DIFFERENTIAL - LARGE - SET
- 901304 HEX SCREW SB M3x4 (10)
- 902316 HEX SCREW SH M3x16 (10)
- 902330 HEX SCREW SH M3x30 (10)
- 903308 HEX SCREW SFH M3x8 (10)
- 903412 HEX SCREW SFH M4x12 (10)

8. CENTER DIFF & BRAKE

STEEL **2x** FIBRE FIBRE **2x** STEEL

CA

TIP

Roughen steel plates with sandpaper before gluing fibre pads

TOP OVAL HOLE

NOTE ORIENTATION

BOTTOM ROUND HOLE

902316
SH M3x16

2x **F=R**

ROUND HOLE NOTE ORIENTATION

OVAL HOLE NOTE ORIENTATION

Fibre pads together

DETAIL

Temporarily insert brake disk between pads to set correct gap

0.5 mm

OPTION #354131
GLUED BRAKE PADS SET-ULTRA EFFICIENT (4)

For improved brake efficiency and increased lifespan use the OPTION brake pads with springs.

! When using optional ultra efficient brake pads you need to remove from the servo holder on radio case.

901304
SB M3x4

903308
SFH M3x8

TL **!** STRAIGHT

! BENT

3.0mm

STRAIGHT

BENT

0mm

DETAIL

OPTION #354057
GRAPHITE CENTER DIFF MOUNTING PLATE

! Must be used for 47T and 48T spur gear.

8. CENTER DIFF & BRAKE

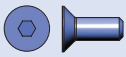

903308
SFH M3x8



903412
SFH M4x12

! NOTE ORIENTATION
OF ALL PARTS

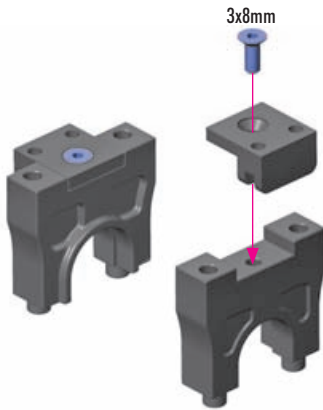

3x8mm

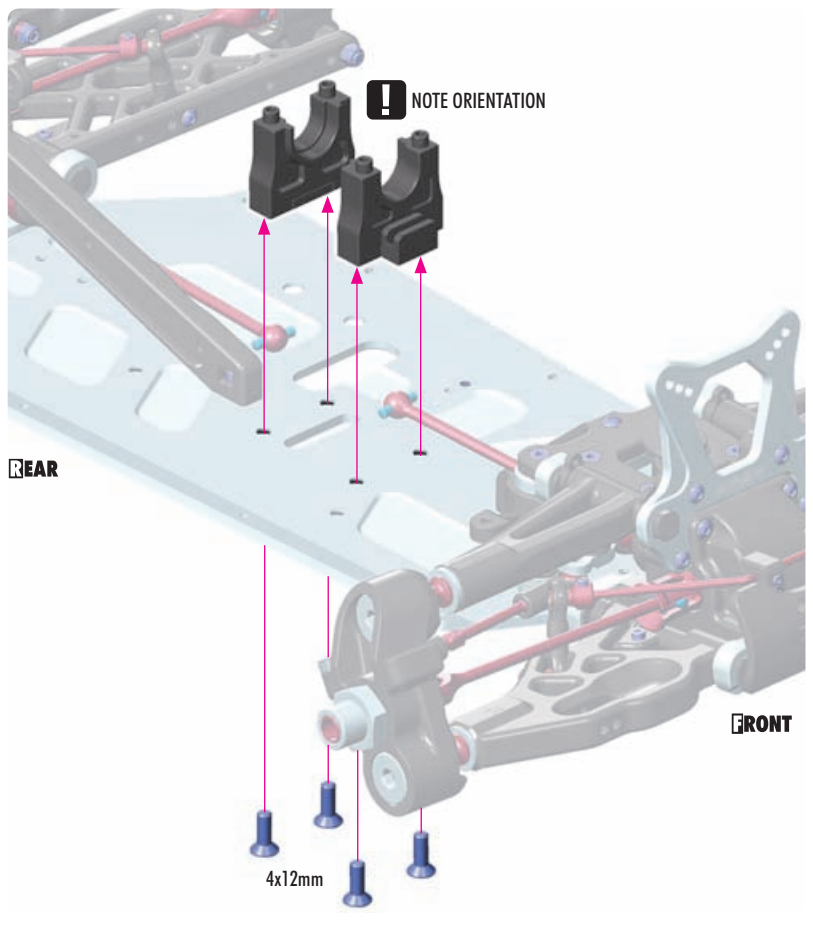

REAR

FRONT

4x12mm



902330
SH M3x30

! NOTE ORIENTATION
OF ALL PARTS

All screws OIL

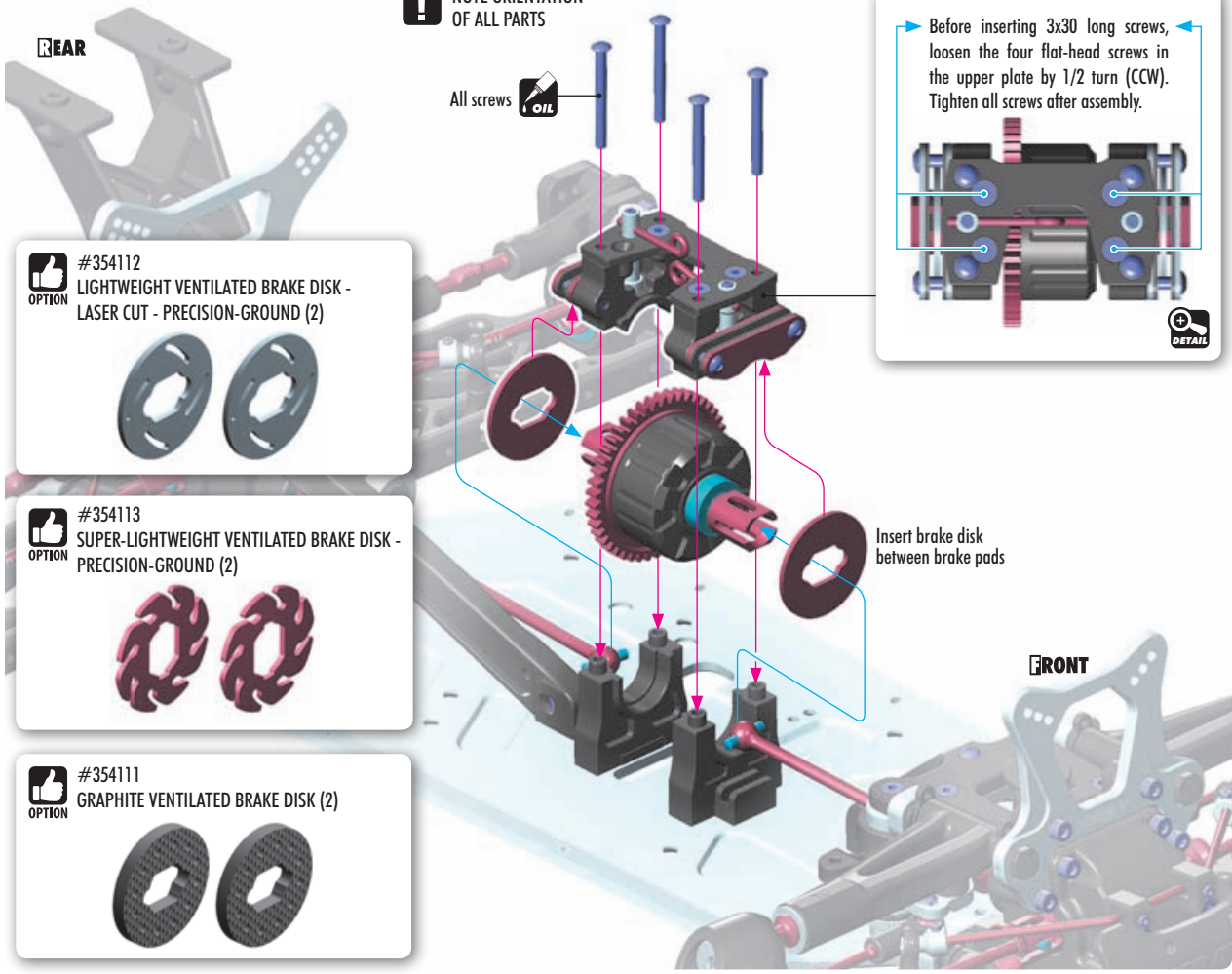

REAR

FRONT

! #354112
OPTION LIGHTWEIGHT VENTILATED BRAKE DISK -
LASER CUT - PRECISION-GROUND (2)



! #354113
OPTION SUPER-LIGHTWEIGHT VENTILATED BRAKE DISK -
PRECISION-GROUND (2)



! #354111
OPTION GRAPHITE VENTILATED BRAKE DISK (2)



Before inserting 3x30 long screws,
loosen the four flat-head screws in
the upper plate by 1/2 turn (CCW).
Tighten all screws after assembly.

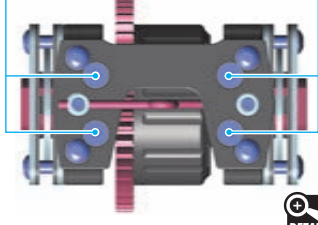

+ DETAIL

Insert brake disk
between brake pads

9. FUEL TANK & ENGINE

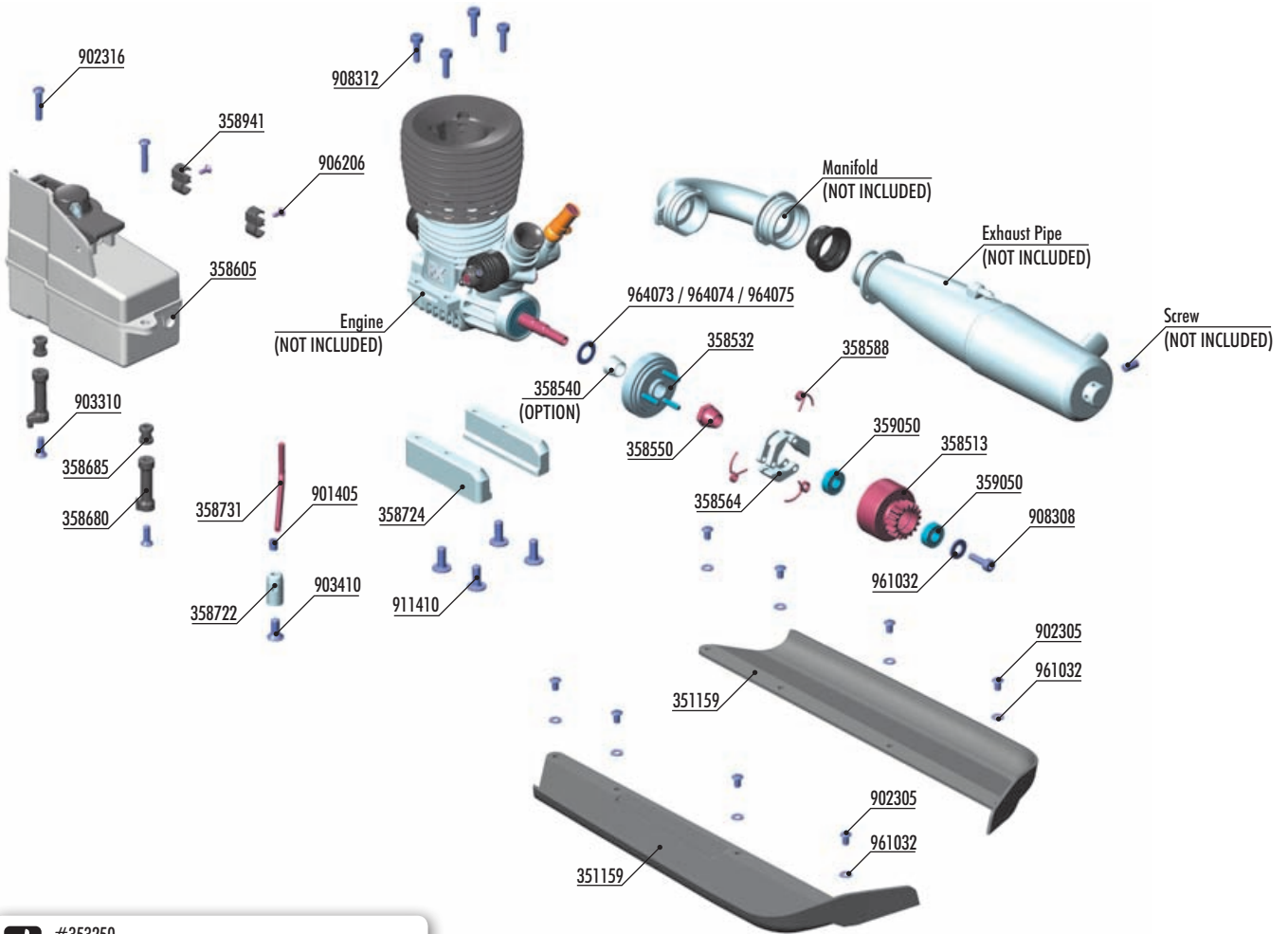

#353250
OPTION GRAPHITE BRACE FOR CHASSIS SIDE GUARDS - SET

#358400
OPTION XRAY COMPLETE 4-SHOE CLUTCH SET

CLUTCH SHOE			
#358563	GRAPHITE (2)	OPTION	
#358564	ALU - HARD (3)	INCLUDED	

HIGH TORQUE CLUTCH SPRING			
#358587	GOLD	SOFT	OPTION
#358588	GRAY	MEDIUM	INCLUDED
#358589	SILVER	HARD	OPTION

CLUTCHBELLS		
#358512	12T	OPTION
#358513	13T	INCLUDED
#358514	14T	OPTION
#358525	15T	OPTION
#358517	13T Lightweight	OPTION
#358518	14T Lightweight	OPTION

BAG



- | | | | |
|--------|--|--------|---------------------------------|
| 351159 | CHASSIS SIDE GUARDS L+R | 901405 | HEX SCREW SB M4x5 (10) |
| 358513 | CLUTCH BELL 13T | 902305 | HEX SCREW SH M3x5 (10) |
| 358532 | FLYWHEEL - HIGH TORQUE | 902316 | HEX SCREW SH M3x16 (10) |
| 358540 | FLYWHEEL COLLAR (OPTION) | 903310 | HEX SCREW SFH M3x10 (10) |
| 358550 | FLYWHEEL NUT - HUDY SPRING STEEL™ | 903410 | HEX SCREW SFH M4x10 (10) |
| 358564 | ALU CLUTCH SHOE - HARD (3) | 906206 | SCREW PHILLIPS FH 2.2x6 (10) |
| 358588 | HIGH TORQUE CLUTCH SPRINGS - MEDIUM (3) | 908308 | HEX SCREW (CAP HEAD) 3x8 (10) |
| 358605 | FUEL TANK 123CC WITH FLOATING FILTER | 908312 | HEX SCREW (CAP HEAD) 3x12 (10) |
| 358680 | FUEL TANK MOUNTING POST (2) | 911410 | HEX SCREW FLANGED SH M4x10 (10) |
| 358685 | FUEL TANK MOUNTING GROMMET (4) | 961032 | WASHER S 3.2 (10) |
| 358722 | EXHAUST WIRE MOUNT SET | 964073 | WASHER S 7x10x0.2 (10) |
| 358724 | ALU ENGINE MOUNT - CNC MACHINED (L+R) | 964074 | WASHER S 7x10x0.3 (10) |
| 358731 | EXHAUST MOUNTING WIRE - LONG | 964075 | WASHER S 7x10x0.5 (10) |
| 358941 | COMPOSITE TUBING HOLDER FOR FUEL TANK (2) | | |
| 359050 | BALL-BEARING 5x10x4 STEEL SEALED - GREASE - V2 (2) | | |

9. FUEL TANK & ENGINE



902305
SH M3x5



961032
S 3.2

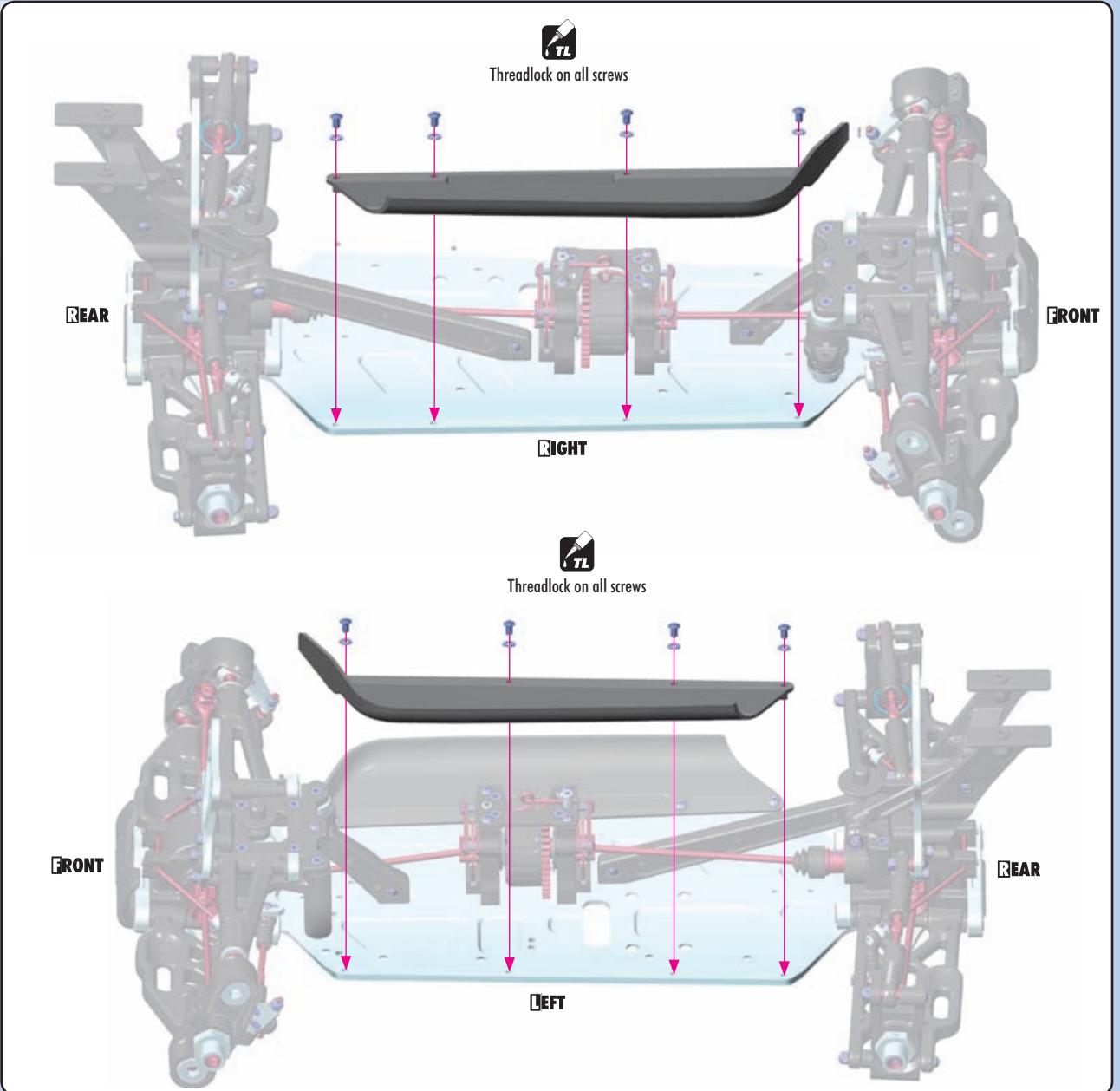

908312
SCH M3x12



964073
S 7x10x0.2



964074
S 7x10x0.3



964075
S 7x10x0.5

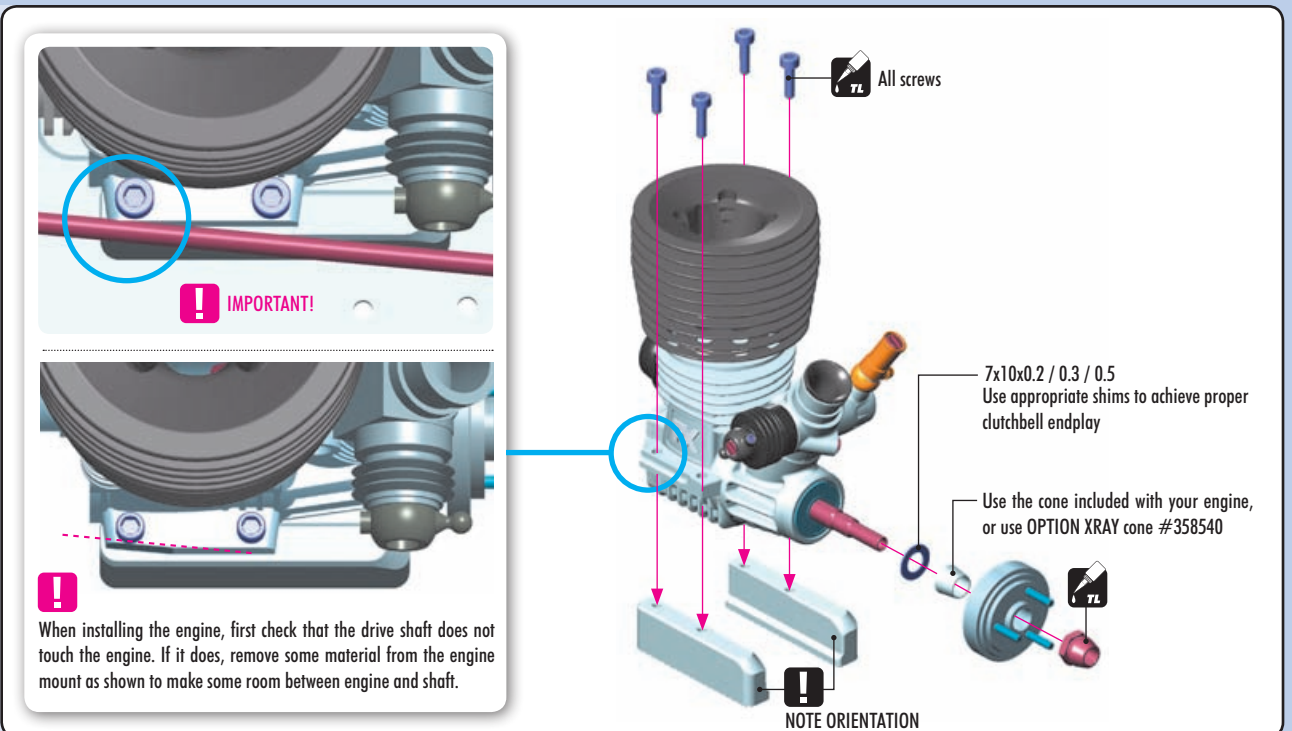

9. FUEL TANK & ENGINE



359050
BB 5x10x4

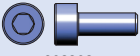

908308
SCH M3x8



961032
S 3.2

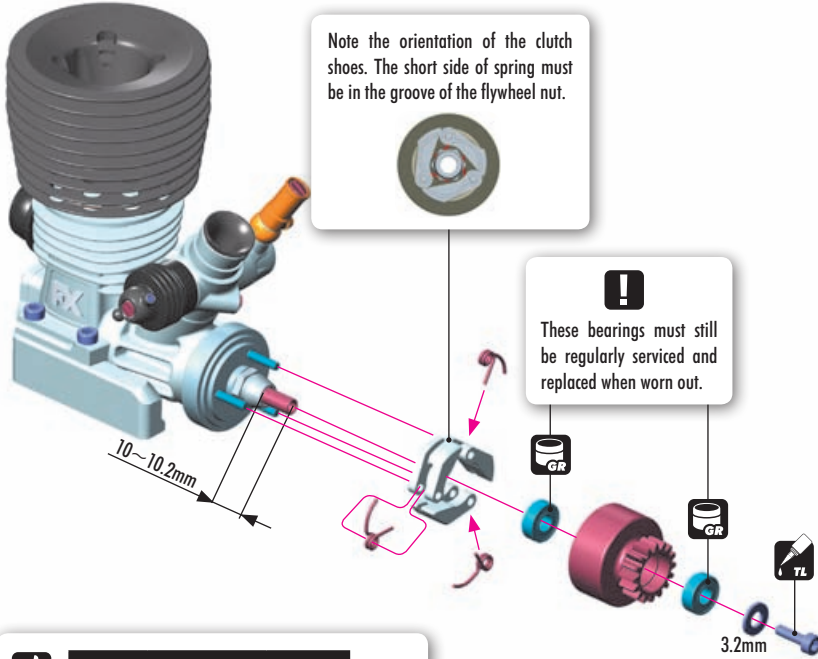

TIP Hold the flywheel using HUDY Flywheel Tool #182015

TIP Tighten the clutch nut using HUDY tool #107581

CLUTCHBELLS

OPTION	Part #	Teeth	Status
	#358512	12T	OPTION
	#358513	13T	INCLUDED
	#358514	14T	OPTION
	#358525	15T	OPTION
	#358517	13T Lightweight	OPTION
	#358518	14T Lightweight	OPTION

HIGH TORQUE CLUTCH SPRING

OPTION	Part #	Material	Stiffness	Status
	#358587	GOLD	SOFT	OPTION
	#358588	GRAY	MEDIUM	INCLUDED
	#358589	SILVER	HARD	OPTION

CLUTCH SHOE

OPTION	Part #	Material	Quantity	Status
	#358563	GRAPHITE	(2)	OPTION
	#358564	ALU - HARD	(3)	INCLUDED

SET-UP BOOK

CLUTCH SPRINGS
CLUTCH SHOE



911410
SHF M4x10

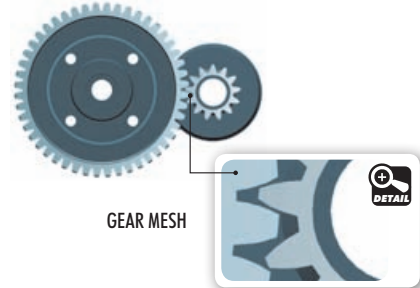
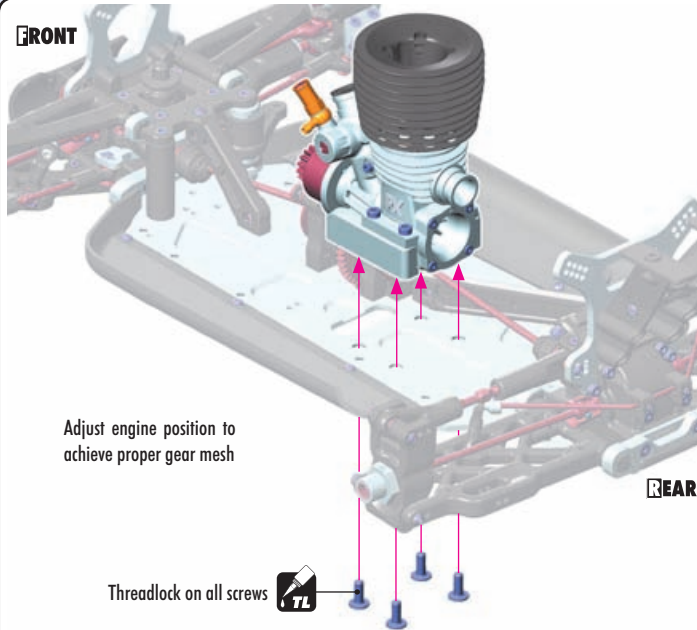

EXTREMELY IMPORTANT

It is very important that your XB8 has properly-adjusted gear mesh. Adjust the gear mesh so there is adequate (or slightly larger) space between the spur gear and clutchbell teeth. Adjust the gear mesh by sliding the engine mounts in the slots of the chassis. You should be able to rock one gear back and forth slightly while holding the other one firmly. Be sure to check the gear mesh all the way around the spur gear. Tighten the screws once the engine alignment and gear mesh are correct, and then re-check the gear mesh to ensure the engine mounts did not move.

SET-UP BOOK

GEARING
GEAR MESH ADJ.



907258
SP 2.5x8

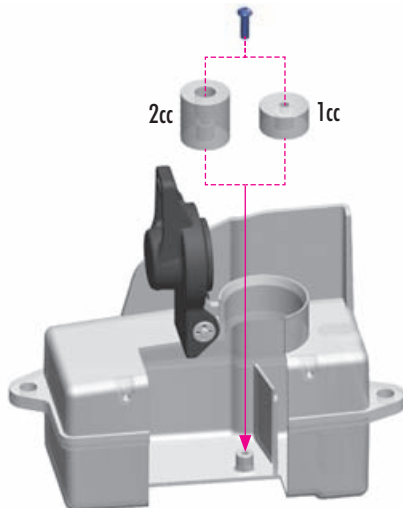

The fuel tank has the larger fuel volume and includes OPTIONAL tank inserts for decreasing the volume of the tank. Using the inserts allows you to adjust the volume of fuel inside the tank; this works in conjunction with variables such as fuel filter capacity and/or length of fuel line to ensure you have the legal fuel volume limit for racing.

Tube holders are easily connected to the fuel tank by screws. Using screws is much more secure than using glue to attach the holders to the fuel tank.

2CC FUEL TANK INSERT

The larger insert decreases the fuel tank volume by 2cc, and is recommended for use when the fuel filter is used.

1CC FUEL TANK INSERT

The smaller insert decreases the fuel tank volume by 1cc.

NOTE ORIENTATION



NOTE ORIENTATION



NOTE: The fuel tank insert can be easily mounted to the bottom of the fuel tank using the provided screw, when the fuel tank cap is opened fully.

9. FUEL TANK & ENGINE



902316
SH M3x16



903310
SFH M3x10



906206
SFP 2.2x6

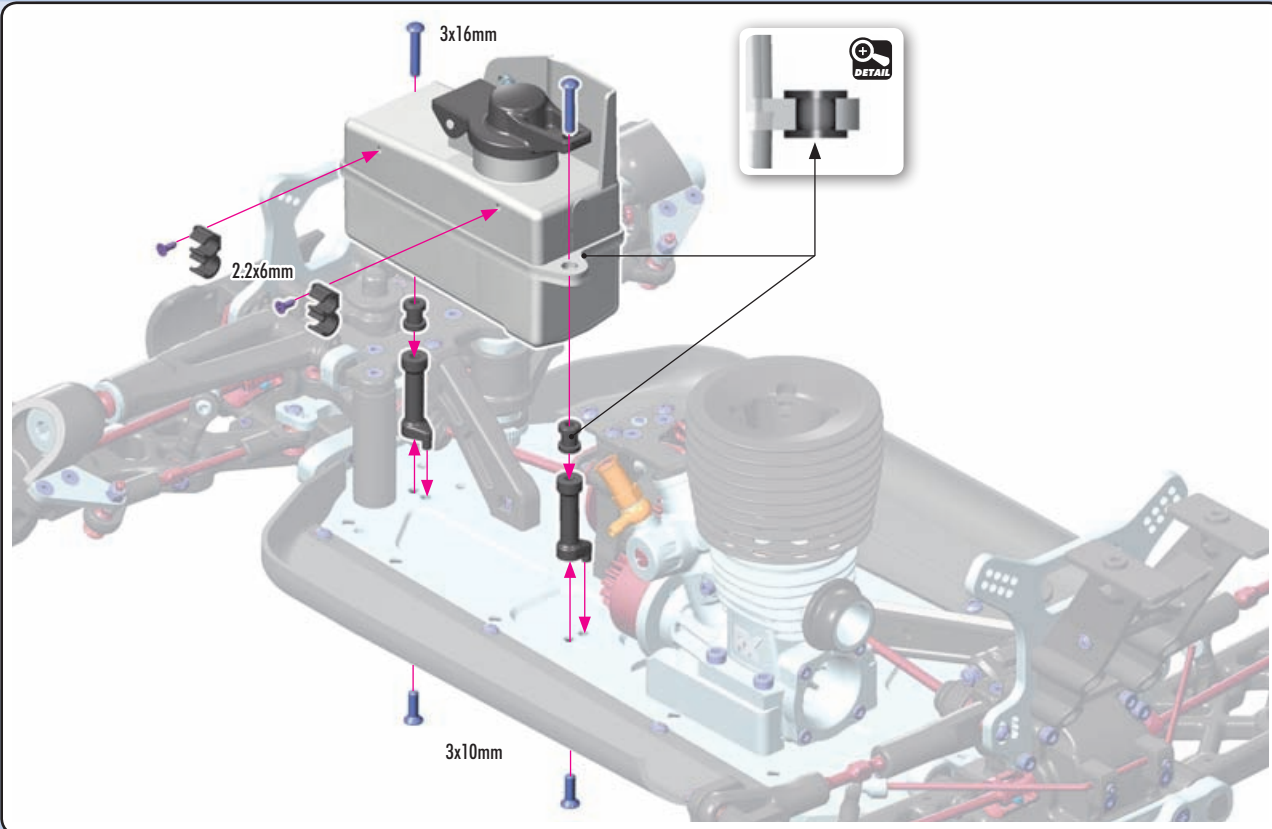

901405
SB M4x5



903410
SFH M4x10

TIP

After running your engine, apply
(#106250 HUDY ENGINE AFTER RUN OIL)

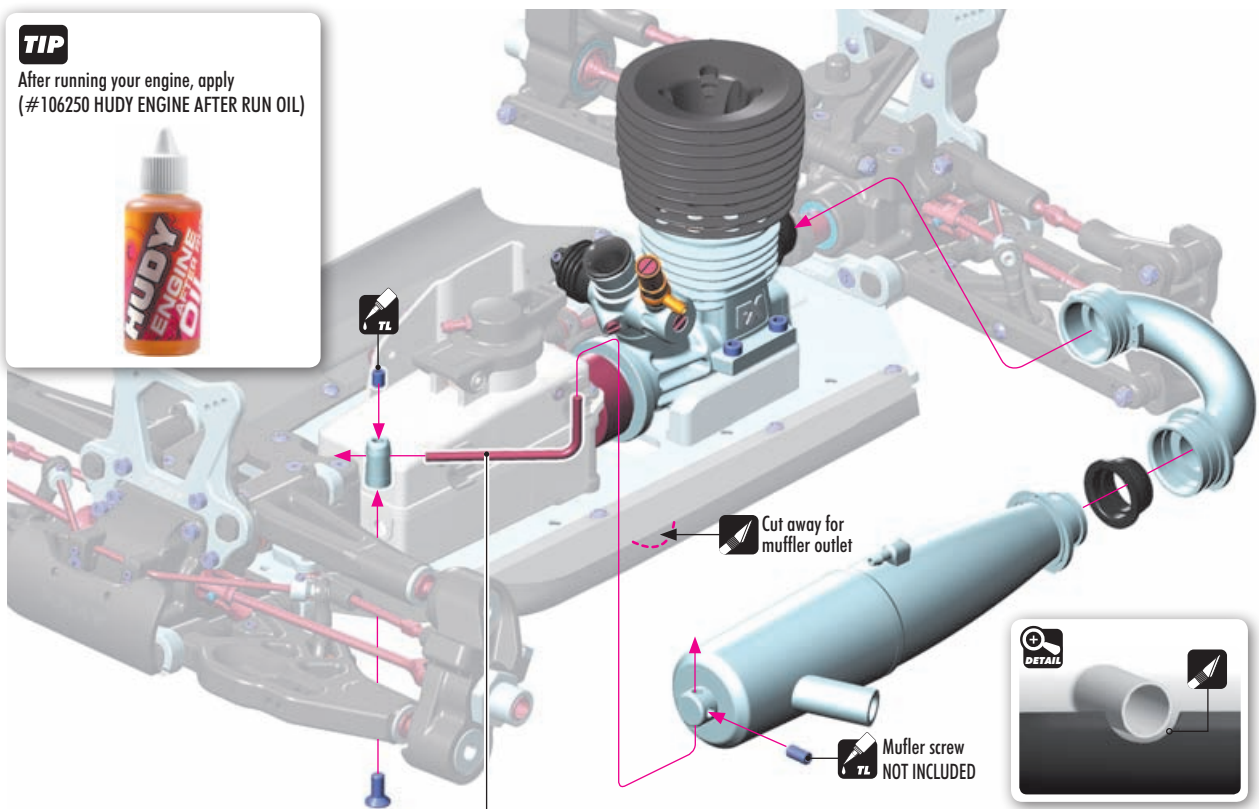

DETAIL



Shorten the wire as appropriate to fit the muffler



Bend the exhaust wire as appropriate to fit the muffler

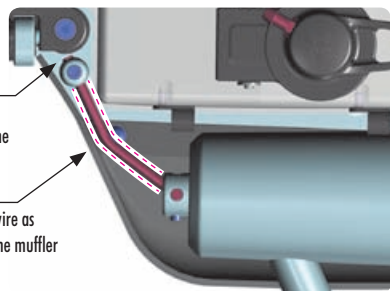

DETAIL



Muffler screw
NOT INCLUDED



DETAIL

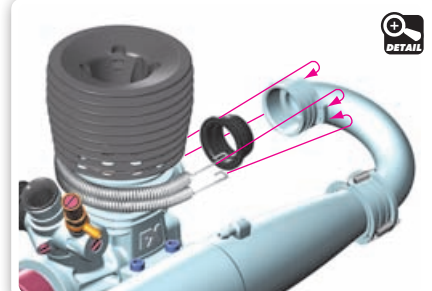

10. RADIO CASE

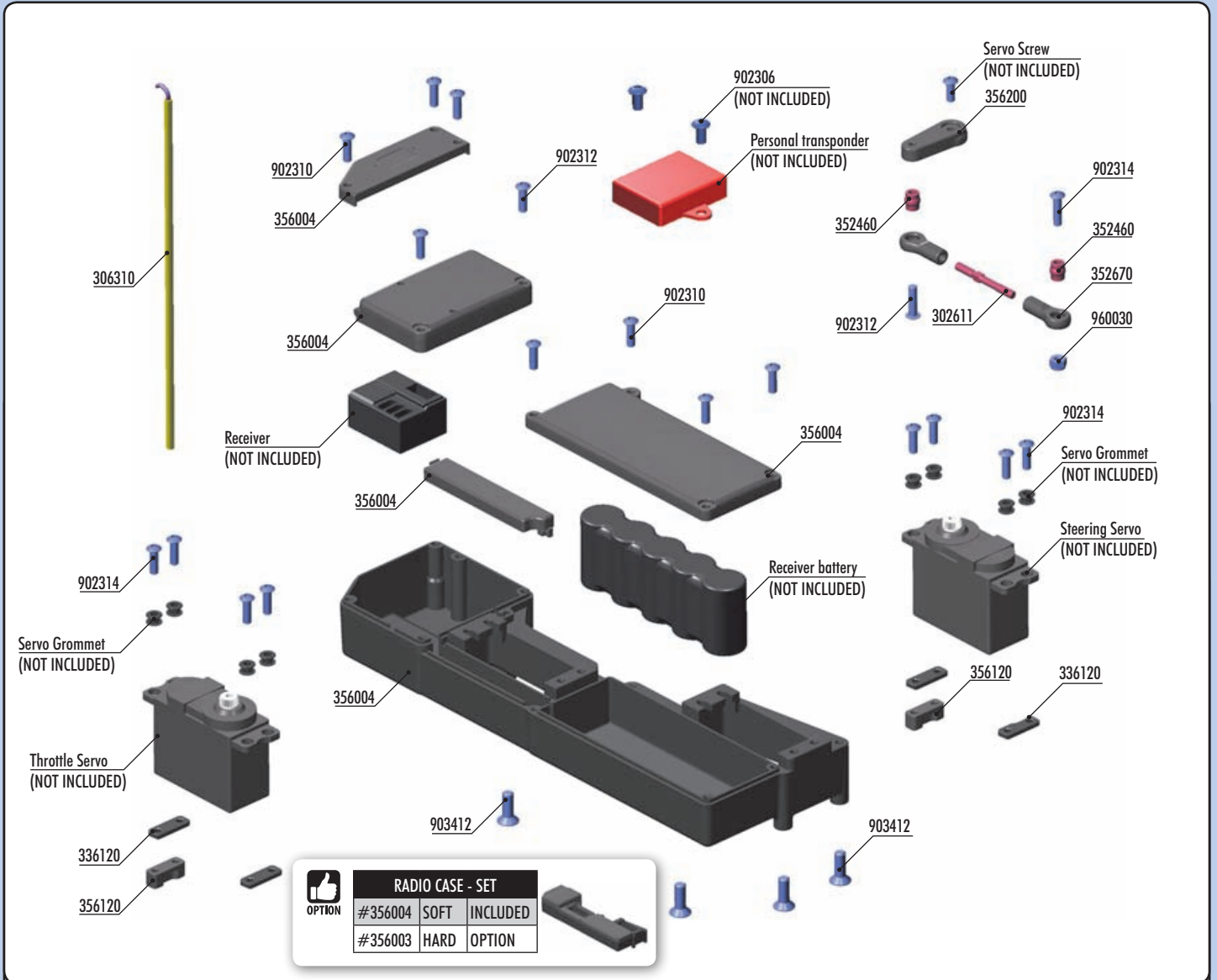

BAG

10

- 30 2611 ADJ. TURNBUCKLE L/R 35 MM - HUDY SPRING STEEL™ (2)
- 30 6310 ANTENNA TUBE (2)
- 33 6120 COMPOSITE STEERING SERVO HOLDER - SET - V2
- 35 2460 PIVOT BALL 5.8 (10)
- 35 2670 SERVO BALL JOINT 5.8MM (4)
- 35 6004 COMPOSITE RADIO CASE SET - SOFT
- 35 6050 BATTERY CABLE WITH SWITCH (OPTION)
- 35 6120 STEERING SERVO MOUNT - SET

- 35 6200 BRAKE/THROTTLE ARMS & STEERING SERVO ARMS - SET
- 38 9135 CONNECTING CABLE RECEIVER/BATT. PACK (OPTION)
- 90 2306 HEX SCREW SH M3x6 (10) (OPTION)
- 90 2310 HEX SCREW SH M3x10 (10)
- 90 2312 HEX SCREW SH M3x12 (10)
- 90 2314 HEX SCREW SH M3x14 (10)
- 90 3412 HEX SCREW SFH M4x12 (10)
- 96 0030 NUT M3 (10)



902312
SH M3x12

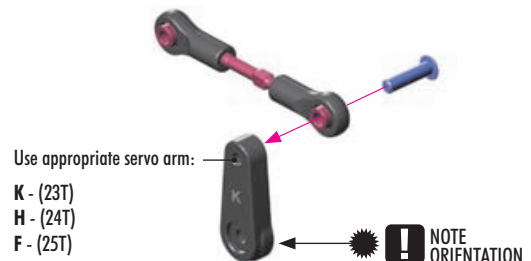
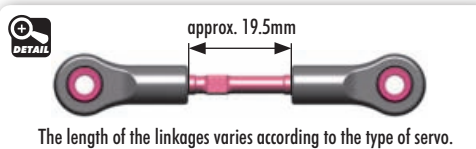
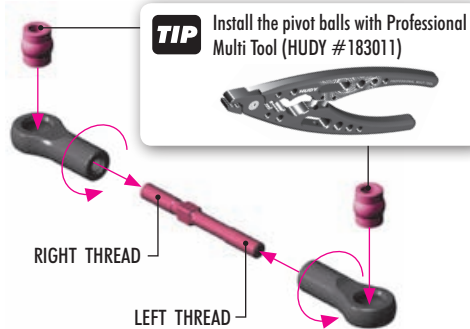

CLAMP ALU SERVO HORNS			
OPTION	#293407	23T	OPTION
HUDY	#293408	24T	OPTION
	#293409	25T	OPTION

ALU SERVO HORNS			
OPTION	#293501	23T	OPTION
HUDY	#293502	24T	OPTION
	#293503	25T	OPTION

10. RADIO CASE

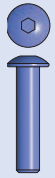

902314
SH M3x14

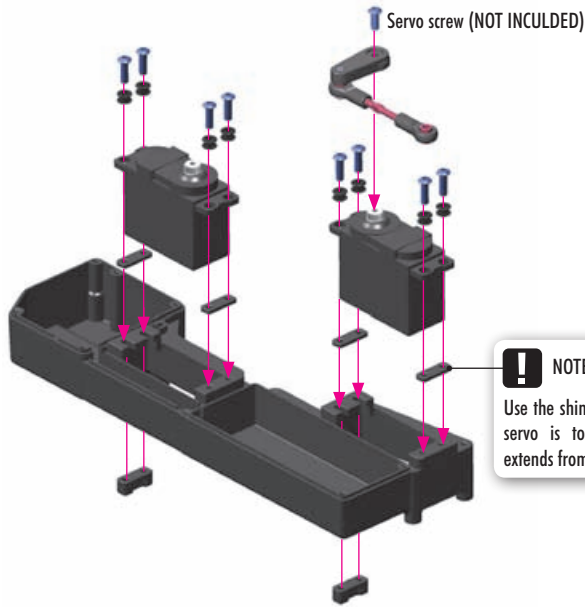

step 1

Plug the connectors into the receiver in Step 2

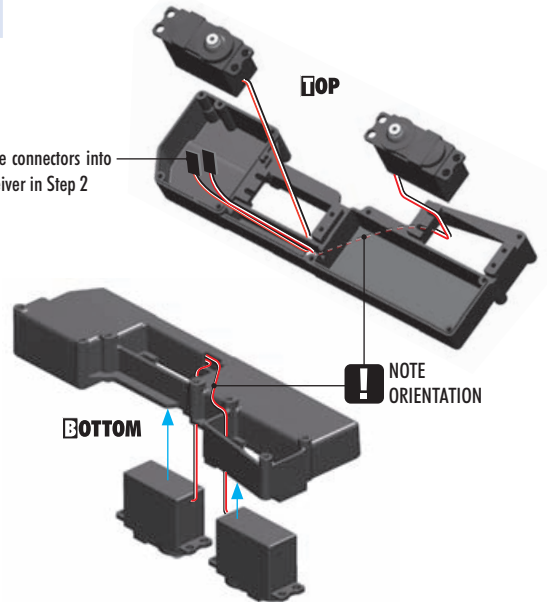

NOTE
Use the shims only if the servo is too high and extends from the case

NOTE
ORIENTATION



902310
SH M3x10



902312
SH M3x12



907206
SP M2x6

step 2

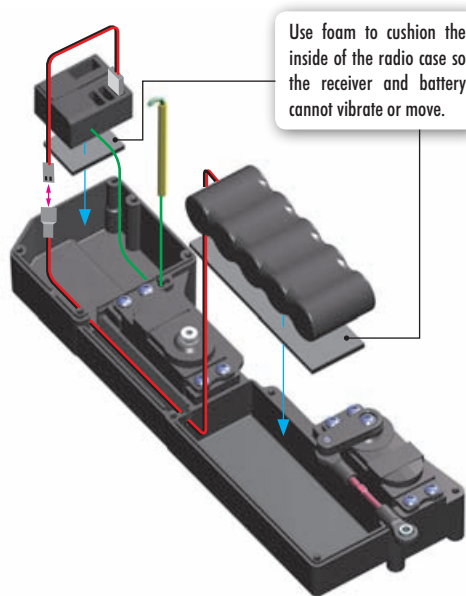

Use foam to cushion the inside of the radio case so the receiver and battery cannot vibrate or move.

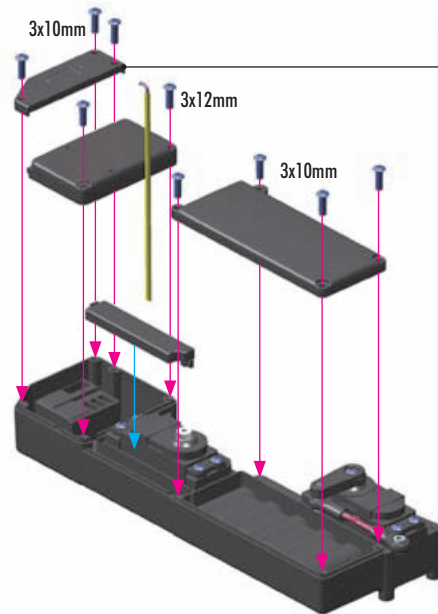

TIP CUT

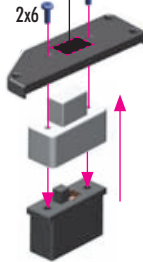

SWITCH #356050
OPTION

When receiver switch is used, use hobby knife to CAREFULLY remove the material from the cover and mount the switch.

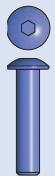

902314
SH M3x14



903412
SFH M4x12



960030
N M3

Personal transponder (NOT INCLUDED)
#902306 Screws (NOT INCLUDED)

Personal transponder can be placed on the top of the radio box or inside of the radio box

ALTERNATIVE 1

When the transponder is placed at the top of the radio box, cut out some material from the radio box in order to allow the transponder wire to come inside.

ALTERNATIVE 2

Place the transponder inside of the radio box by using double-sided tape.

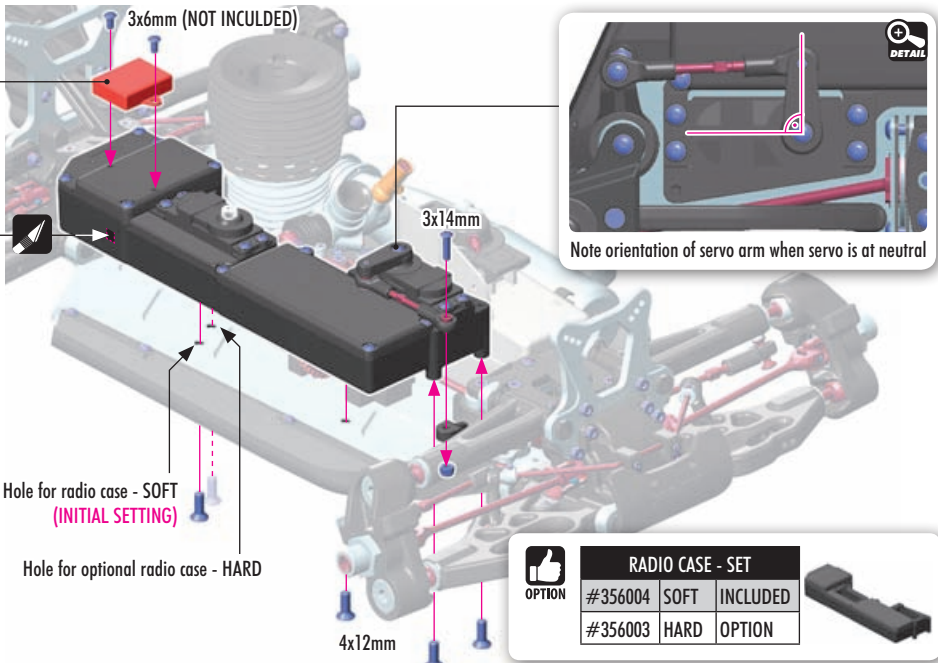

Hole for radio case - SOFT
(INITIAL SETTING)

Hole for optional radio case - HARD

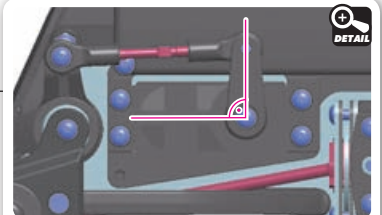

Note orientation of servo arm when servo is at neutral

RADIO CASE - SET		
#356004	SOFT	INCLUDED
#356003	HARD	OPTION



11. SHOCK ABSORBERS

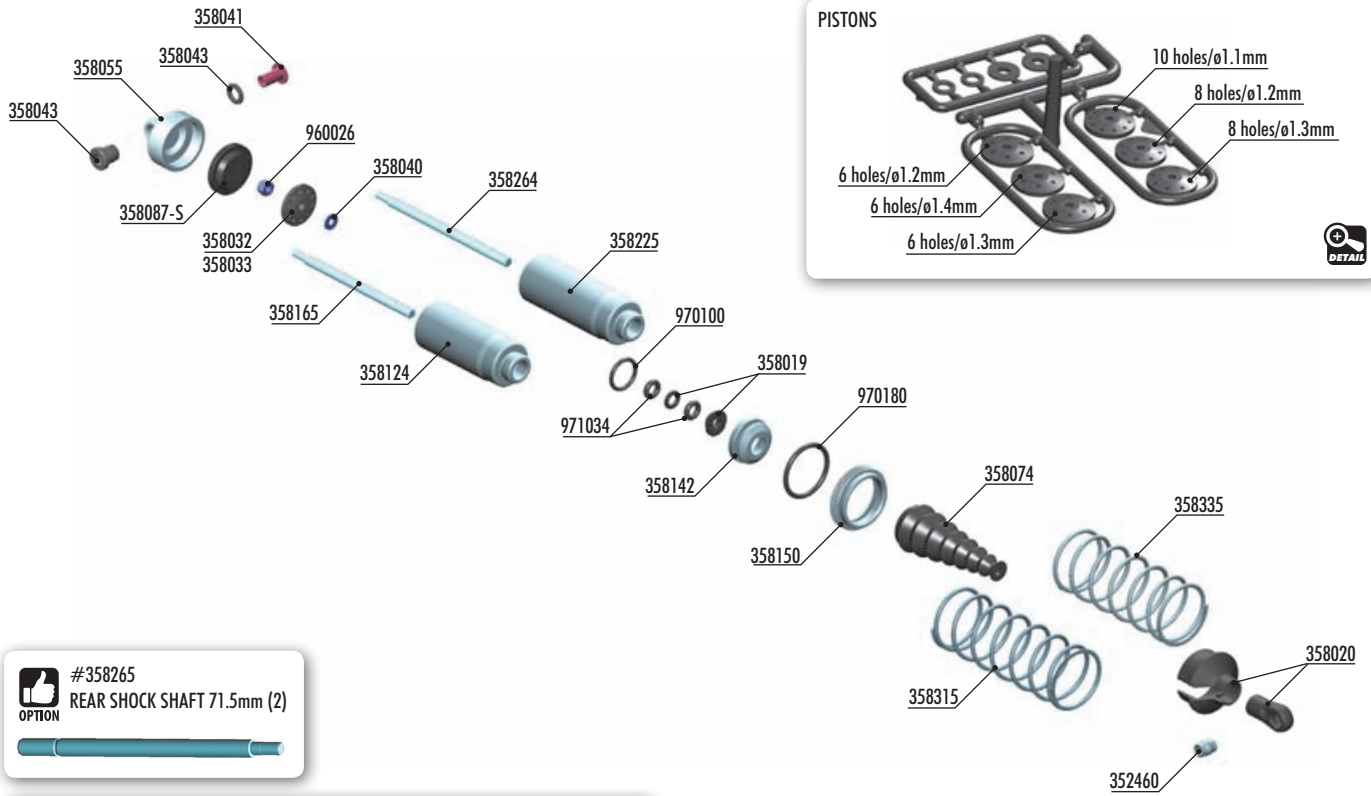

#358265
OPTION
 REAR SHOCK SHAFT 71.5mm (2)

#358027 PISTON 5-HOLE (1.5mm) & 2-HOLE (1.0mm) (4)
#358028 PISTON 6-HOLE (1.3mm) & 2-HOLE (1.1mm) (4)
#308029 PISTON 6-HOLE (1.4mm) & 2-HOLE (1.1mm) (4)
#358030 PISTON 8-HOLE (1.2mm) & 2-HOLE (1.2mm) (4)
#358031 PISTON 8-HOLE (1.3mm) & 2-HOLE (1.2mm) (4)

OPTION

FRONT LINEAR SPRINGS				
#358182	C=0.65	White	SHORT	OPTION
#358183	C=0.70	Grey	SHORT	OPTION
#358184	C=0.75	Silver	SHORT	OPTION
#358185	C=0.80	Grey-Blue	SHORT	OPTION
#358186	C=0.86	Blue	SHORT	OPTION
#358187	C=0.92	Violet	SHORT	OPTION
#358188	C=0.98	Purple	SHORT	OPTION

OPTION

REAR LINEAR SPRINGS				
#358282	C=0.47	White	LONG	OPTION
#358283	C=0.50	Grey	LONG	OPTION
#358284	C=0.53	Silver	LONG	OPTION
#358285	C=0.57	Grey-Blue	LONG	OPTION
#358286	C=0.61	Blue	LONG	OPTION
#358287	C=0.65	Violet	LONG	OPTION
#358288	C=0.70	Purple	LONG	OPTION

OPTION

SHOCK SPRINGS				
#358315	C=0.77-0.80	3 DOTS	FRONT	INCLUDED
#358316	C=0.80-0.83	4 DOTS	FRONT	OPTION
#358317	C=0.83-0.86	5 DOTS	FRONT	OPTION
#358335	C=0.68-0.70	3 DOTS	REAR	INCLUDED
#358336	C=0.70-0.73	4 DOTS	REAR	OPTION

OPTION

FRONT & REAR PROGRESSIVE SPRINGS				
#358174	C=0.7-0.8	Grey	SHORT	OPTION
#358274	C=0.5-0.6	Grey	MEDIUM	OPTION
#358275	C=0.65-0.7	1 STRIPE	MEDIUM	OPTION
#358276	C=0.7-0.75	2 STRIPES	MEDIUM	OPTION
#358277	C=0.72-0.8	3 STRIPES	MEDIUM	OPTION
#358278	C=0.75-0.83	4 STRIPES	MEDIUM	OPTION

OPTION

REAR PROGRESSIVE SPRINGS				
#358279	C=0.55-0.63	2 STRIPES	LONG	OPTION
#358280	C=0.6-0.68	3 STRIPES	LONG	OPTION
#358281	C=0.65-0.7	4 STRIPES	LONG	OPTION

#104005
OPTION
 HUDY AIR VAC - VACUUM PUMP
 - 1/8 OFF-ROAD



#358054
OPTION
 XB8 ALU SHOCK CAP NUT WITH
 VENT HOLE - BLACK COATED (2)



BAGS



352460	PIVOT BALL 5.8 - V3 (10)	358142	ALU SHOCK BODY NUT FOR SHOCK BOOT (2)
358019	COMPOSITE SET OF SHIMS FOR SHOCKS - V2 (2)	358150	ALU SHOCK BODY ADJ. NUT (2)
358020	COMPOSITE SHOCK PARTS	358165	FRONT SHOCK SHAFT 61mm (2)
358032	SHOCK PISTON SET 8-HOLE (1.2; 1.3) 10-H. (1.1MM) - DELRIN - V2	358225	ALU REAR SHOCK BODY - HARD COATED (2)
358033	COMPOSITE SHOCK 6-HOLE PISTON SET (1.2; 1.3; 1.4MM) - DELRIN - V2	358264	REAR SHOCK SHAFT 67.5mm (2)
358040	HARDENED SHOCK SHIMS (4)	358315	XRAY FRONT SPRING 69MM - 3 DOTS (2)
358041	STEEL SHOCK BUSHING (2)	358335	XRAY REAR SPRING 85MM - 3 DOTS
358043	COMPOSITE SHOCK BUSHING & SHIM (2+2)	960026	NUT M2.5 - SHORT (10)
358055	ALU SHOCK CAP NUT WITH 4 VENT HOLES - BLACK COATED (2)	970100	O-RING 10 x 1.5 (10)
358074	FOLDING SHOCK BOOT (4)	970180	O-RING 18 x 1.8 (10)
358087-S	SHOCK RUBBER MEMBRANE CELL - SOFT (4)	971034	SILICONE O-RING 3.5x2 (10)
358124	ALU FRONT SHOCK BODY - HARD COATED (2)		

11. SHOCK ABSORBERS



358040
S 2.5x6x0.5



960026
N M2.5

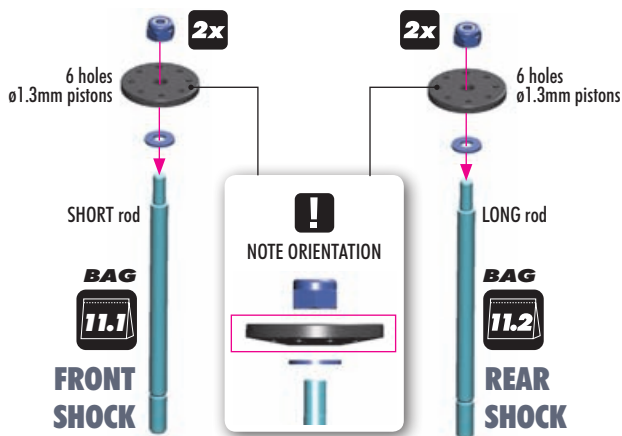

Install the piston with Professional Multi Tool (HUDY #183011)

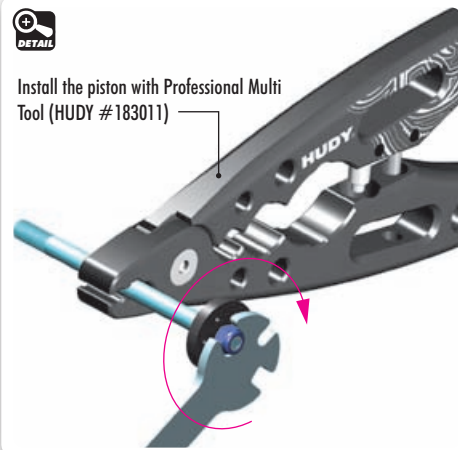

#358265
REAR SHOCK SHAFT 71.5mm (2)



#358027 PISTON 5-HOLE (1.5mm) & 2-HOLE (1.0mm) (4)
#358028 PISTON 6-HOLE (1.3mm) & 2-HOLE (1.1mm) (4)
#308029 PISTON 6-HOLE (1.4mm) & 2-HOLE (1.1mm) (4)
#358030 PISTON 8-HOLE (1.2mm) & 2-HOLE (1.2mm) (4)
#358031 PISTON 8-HOLE (1.3mm) & 2-HOLE (1.2mm) (4)



DO NOT OVERTIGHTEN

The self-locking nut is overtightened, causing distortion of the piston. This will negatively affect the free movement of the piston in the shock body.

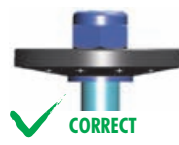

TIGHTEN GENTLY

The self-locking nut is gently tightened. The piston remains undistorted and fits inside the shock body perfectly, ensuring smooth movement of the piston.

SET-UP BOOK

SHOCK DAMPING
SHOCK PISTONS



970100
O 10x1.5



971034
O 3.4x2

2x FRONT SHOCKS (SHORT)

2x REAR SHOCKS (LONG)

There are two different thickness shims, use them as shown. Use the same procedure when building both front and rear shocks.

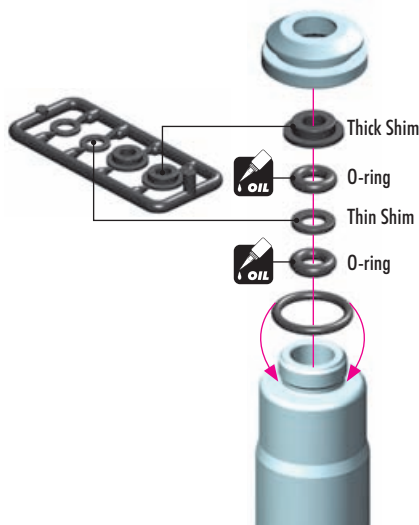

2x

FRONT SHOCKS

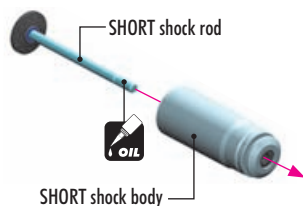

2x

REAR SHOCKS

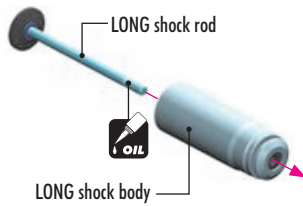

EXTREMELY IMPORTANT

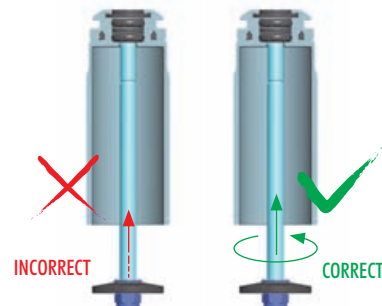

Do not push the shock rod straight through the lower shock body assembly; O-ring damage may result.

Twist the shock rod through the lower shock body assembly.

11. SHOCK ABSORBERS



970180
O 18x1.8

2x FRONT SHOCKS

2x REAR SHOCKS

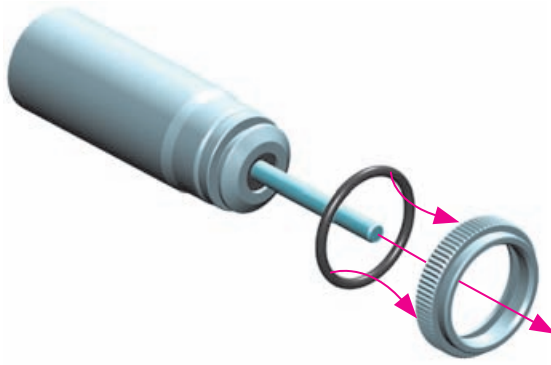

2x FRONT SHOCKS

2x REAR SHOCKS

Professional Multi Tool
(HUDY #183011)

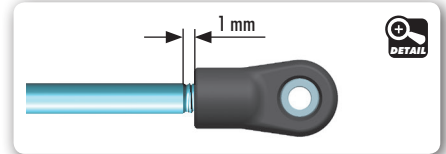
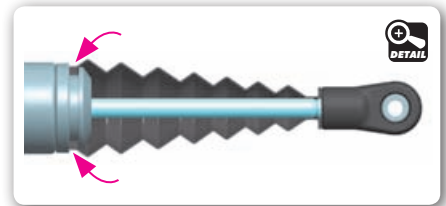
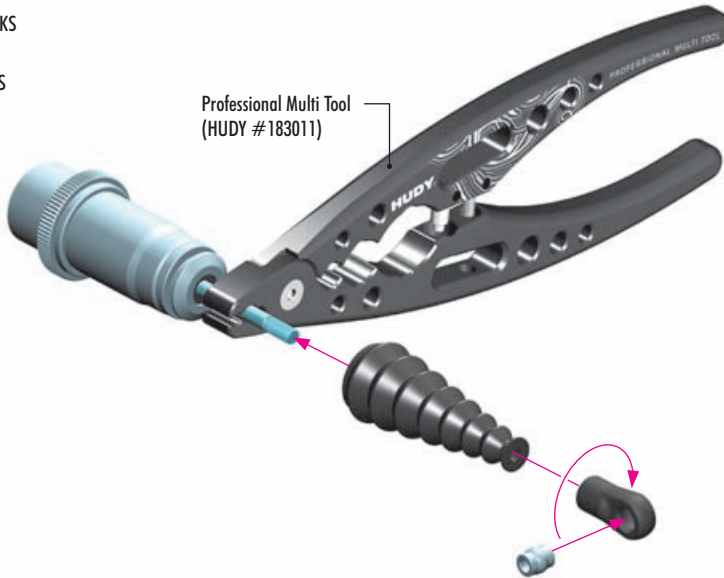

DEFAULT SHOCK REBOUND SETTING 0% (LOW REBOUND)

Follow the steps below to set the shock rebound to the default setting of 0%.

2x FRONT (SHORT)

Oil 450cSt

2x REAR (LONG)

Oil 350cSt

SET-UP BOOK
SHOCK OIL



1 Extend the shock shaft completely. Fill the shock body with the shock oil. For the FRONT shocks (short) use 450cSt oil. For the REAR shocks (long) use 350cSt oil.



2 Move the shock shaft up and down a few times to release the air bubbles trapped beneath the piston.



3 Orient the filled shock vertically for several minutes with the shock shaft fully extended. The remaining air bubbles will release.

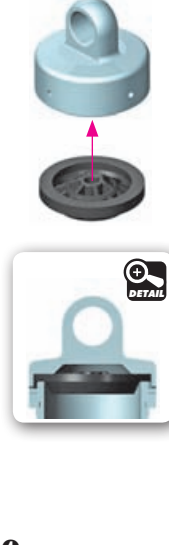

4 Install the shock membrane into the groove in the upper shock cap.



5 Gently place the shock cap assembly onto the filled shock body. Excess oil will spill from the shock. Screw the shock cap onto the body by only a few turns.

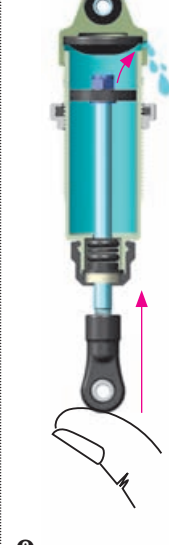

6 Gently push the shock shaft completely into the shock body. Excess oil will flow through the hole in the shock cap.



7 Keep the shock shaft pushed in the shock body and tighten the shock cap completely. The rebound will be at approximately 0%.

2x REAR SHOCKS
LONG rear shock

2x FRONT SHOCKS
SHORT front shock

LONG spring

SHORT spring

REAR shock PRELOAD
approx. 2mm

FRONT shock PRELOAD
approx. 2mm

SET-UP BOOK
SPRING RATE SHOCK PRELOAD RIDE HEIGHT

IMPORTANT! Both rear shocks must be the same overall length.

IMPORTANT! Both front shocks must be the same overall length.

DETAIL
FRONT & REAR SHOCKS
IMPORTANT!

TIP ALTERNATE SHOCK REBOUND SETTING (50% AND 100%)

The default shock rebound setting is 0% (as described on page 40). Alternatively, you may set the shock rebound setting to 50% or 100% as described below. Remove the shock springs before performing shock rebound adjustment.

SETTING THE SHOCK REBOUND TO 50% (MEDIUM REBOUND)

REMOVE SHOCK CAP

1 Extend the shock shaft completely and remove the shock cap.

2 Fill the shock body with shock oil up to the top. Make sure to use same viscosity shock oil as is in the shock.

3 Orient the filled shock vertically for several minutes with the shock shaft fully extended. The remaining air bubbles will release.

4 Gently place the shock cap assembly onto the filled shock body. Excess oil will spill from the shock.

5 Push the shock shaft 50% into the shock body. Excess oil will bleed through the hole in the shock cap.

6 Keep the shock shaft pushed 50% into the shock body and tighten the shock cap completely. The rebound will be at approximately 50%.

SETTING THE SHOCK REBOUND TO 100% (HIGH REBOUND)

REMOVE SHOCK CAP

1 Extend the shock shaft completely and remove the shock cap.

2 Fill the shock body with shock oil up to the top. Make sure to use same viscosity shock oil as is in the shock.

3 Orient the filled shock vertically for several minutes with the shock shaft fully extended. The remaining air bubbles will release.

4 Gently place the shock cap assembly onto the filled shock body. Keep the shock shaft extended 100% from the shock body and tighten the shock cap completely. The rebound will be at approximately 100%.

12. FINAL ASSEMBLY

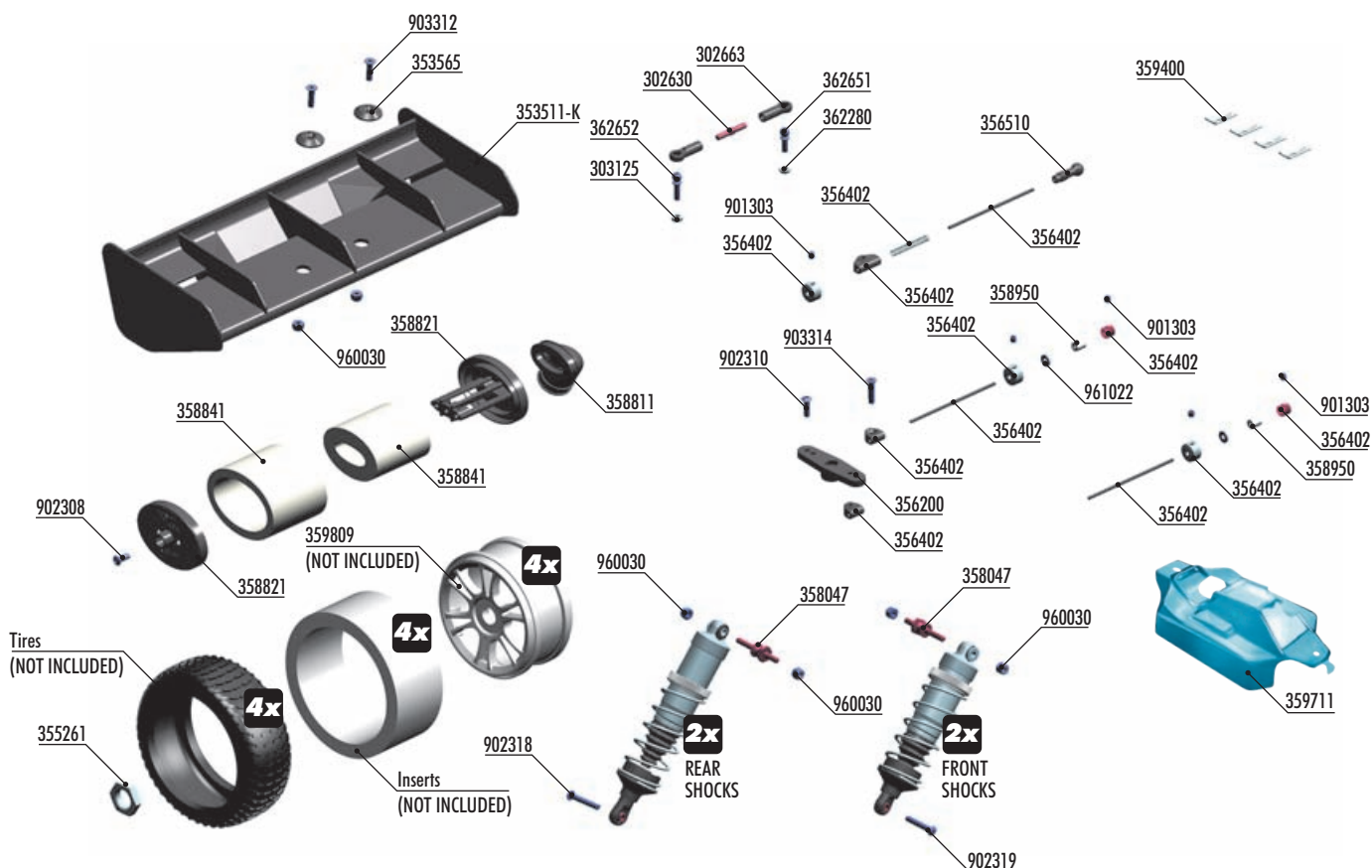

#358832
AIR FILTER RAIN COVER
OPTION



XRAY STARBURST WHEELS

#359808	PINK	OPTION
#359809	YELLOW	OPTION



WHEEL NUTS

#355261	OPEN	INCLUDED
#293560	COVERED	OPTION
#355265	COVERED	OPTION



WING SHIMS

#353565	COMPOSITE	INCLUDED
#293561	ALU	OPTION
#293561-0	ALU	OPTION
#353561	ALU	OPTION



CLAMP ALU SERVO HORNS

#293444	23T	OPTION
#293445	24T	OPTION
#293446	25T	OPTION
#293447	23T	OPTION
#293448	24T	OPTION
#293449	25T	OPTION



ALU SERVO HORNS

#293504	23T	OPTION
#293505	24T	OPTION
#293506	25T	OPTION
#293507	23T	OPTION
#293508	24T	OPTION
#293509	25T	OPTION



#359712
BODY HIGH-SPEED - LIGHTWEIGHT
OPTION



WINGS

#353511-K	BLACK	INCLUDED
#353511	WHITE	OPTION
#353511-Y	YELLOW	OPTION
#353512	LEXAN®	OPTION



- 302630 ADJ. TURNBUCKLE L/R 20 MM - HUDY SPRING STEEL™ (2)
- 302663 COMPOSITE BALL JOINT 4.9MM - OPEN - V2 (8)
- 303125 ALU SHIM 3x6x3.0MM (10)
- 353511-K XB8 REAR WING - BLACK
- 353565 COMPOSITE REAR WING SHIM - BLACK (2)
- 355261 WHEEL NUT - RIBBED - HARD COATED (2)
- 356200 BRAKE/THROTTLE ARMS & SERVO ARMS - SET
- 356402 XB8 BRAKE/THROTTLE SYSTEM - SET
- 356510 CLOSED BALL JOINT 3.9 (4)
- 358047 STEEL SCREW SHOCK PIVOT BALL WITH HEX (2)
- 358811 AIR FILTER ELBOW - LOW PROFILE
- 358821 AIR FILTER BODY & CAP - LOW PROFILE
- 358841 AIR FILTER FOAM & OIL - LOW PROFILE
- 358950 SILICONE TUBING 1M (2.4 x 5.5MM)
- 359400 BODY CLIP (10)

- 359711 XB8 BODY HIGH-SPEED FOR 1/8 OFF-ROAD BUGGY
- 362280 ALU CONICAL SHIM 3x6x2.0MM (10)
- 362651 BALL END 4.9MM WITH THREAD 8MM (2)
- 362652 BALL END 4.9MM WITH THREAD 10MM (2)
- 901303 HEX SCREW SB M3x3 (10)
- 902308 HEX SCREW SH M3x8 (10)
- 902310 HEX SCREW SH M3x10 (10)
- 902318 HEX SCREW SH M3x18 (10)
- 902319 HEX SCREW SH M3x18 - LEFT THREAD (10)
- 903312 HEX SCREW SFH M3x12 (10)
- 903314 HEX SCREW SFH M3x14 (10)
- 960030 NUT M3 (10)
- 961022 WASHER S 2.2 (10)

12. FINAL ASSEMBLY

FRONT SHOCKS (SHORT)

2x

L-R

902318 SH M3x18

902319 SH M3x18 LEFT thread

960030 N M3

SHORTER ← → LONGER

! NOTE ORIENTATION

! Use **STANDARD** M3x18 screw

FRONT

LEFT

RIGHT

3x18mm

On the front right arm use the **SILVER** M3x18 screw - this screw has **LEFT THREAD** **!**

DETAIL

L-R

INITIAL SETTING

DETAIL

INITIAL SETTING

L-R

REAR SHOCKS (LONG)

2x

L-R

902318 SH M3x18

902319 SH M3x18 LEFT thread

960030 N M3

SHORTER ← → LONGER

! NOTE ORIENTATION

! Use **STANDARD** M3x18 screw

REAR

RIGHT

LEFT

M3x18mm

On the rear left arm use the **SILVER** M3x18 screw - this screw has **LEFT THREAD** **!**

DETAIL

INITIAL SETTING

DETAIL

INITIAL SETTING

L-R

901303 SB M3x3

902310 SH M3x10

903314 SFH M3x14

Thread brake rods into plastic pivots until flush with outer end

Brake rod

Brake rod

Throttle rod

! Use servo horn to match your servo

Cut off remaining material

K - (23T) H - (24T) F - (25T)

ALU SERVO HORNS		
OPTION HUDY	#293504	23T
	#293505	24T
	#293506	25T
	#293507	23T
	#293508	24T
	#293509	25T

CLAMP ALU SERVO HORNS		
OPTION HUDY	#293444	23T
	#293445	24T
	#293446	25T
	#293447	23T
	#293448	24T
	#293449	25T

DETAIL

Small gap

Small gap

Tighten screw until snug. Pivots should move freely.

12. FINAL ASSEMBLY

901303
SB M3x3

961022
S 2.2

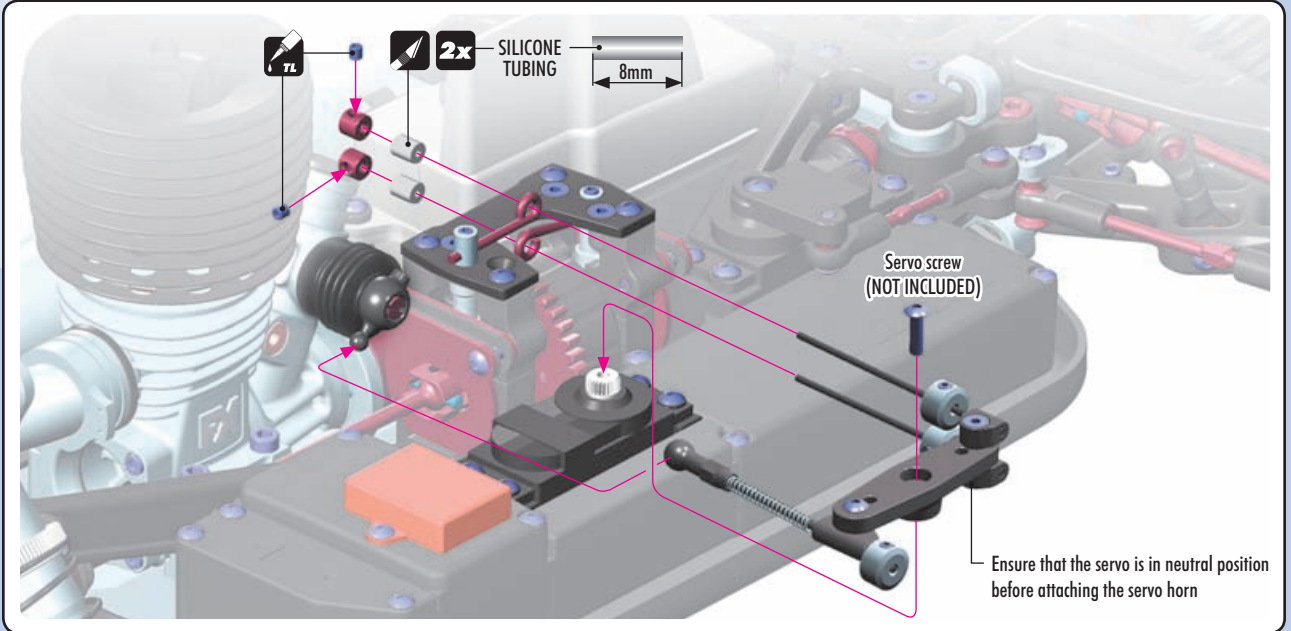

303125
SHIM 3x6x3

362280
CON. SHIM 3x6x2

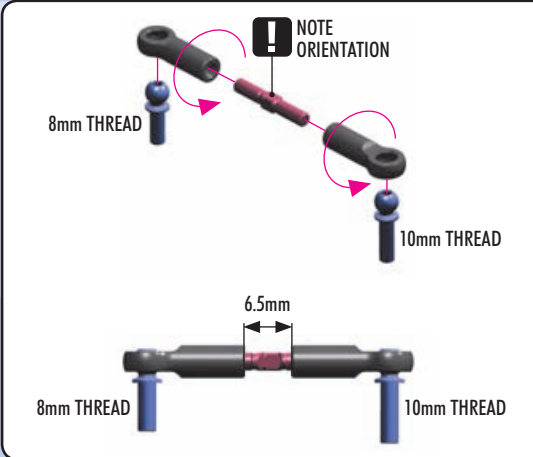

- 1 Remove the screws from mounting plate and servo horn
- 2 Install the servo brace
- 3 Check free move

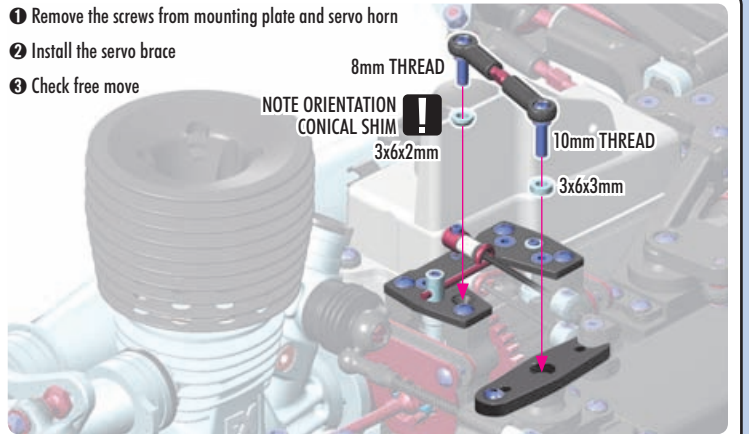

903312
SFH M3x12

960030
N M3

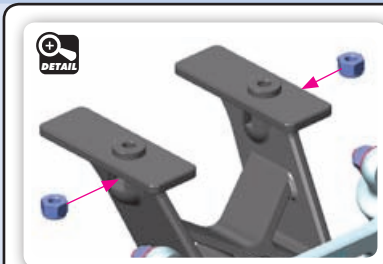

WINGS			
OPTION	#353511-K	BLACK	INCLUDED
	#353511	WHITE	OPTION
	#353511-Y	YELLOW	OPTION
	#353512	LEXAN®	OPTION



WING SHIMS			
OPTION	#353565	COMPOSITE	INCLUDED
	#293561	ALU	OPTION
	#293561-0	ALU	OPTION
	#353561	ALU	OPTION

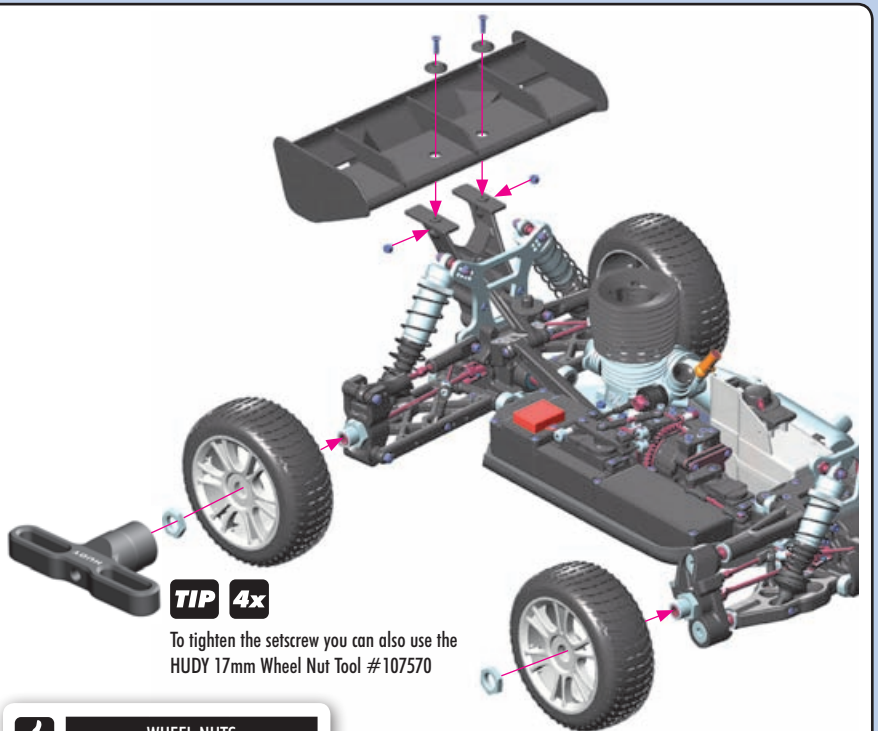

TIP 4x
To tighten the setscrew you can also use the HUDY 17mm Wheel Nut Tool #107570

WHEEL NUTS			
OPTION	#355261	OPEN	INCLUDED
	#293560	COVERED	OPTION
	#355265	COVERED	OPTION

XRAY STARBURST WHEELS			
OPTION	#359808	Pink	OPTION
	#359809	Yellow	OPTION



#358832
AIR FILTER RAIN COVER
OPTION

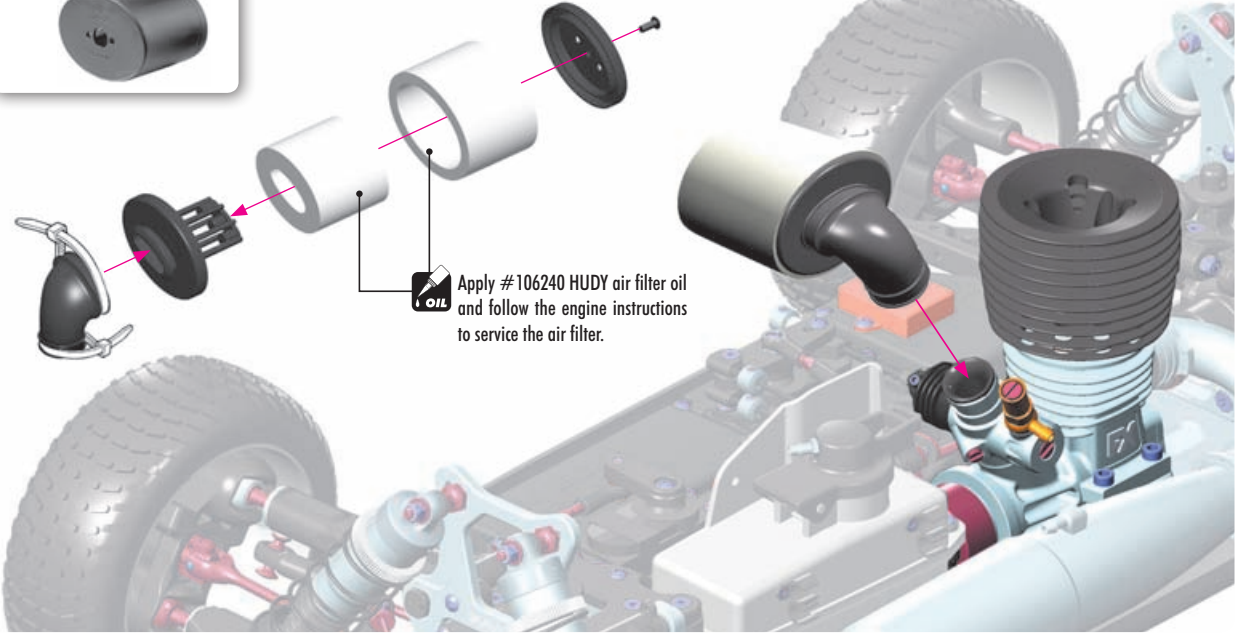

Cut the silicone tube depending on engine and muffler. Use the plastic clips to hold the tubes together.

SILICONE TUBE MARKED AS
BLUE = FROM FUEL TANK TO CARBURETOR

SILICONE TUBE MARKED AS
RED = FROM MUFFLER TO FUEL TANK (TOP)

! Keep fuel line away from clutchbell and flywheel.

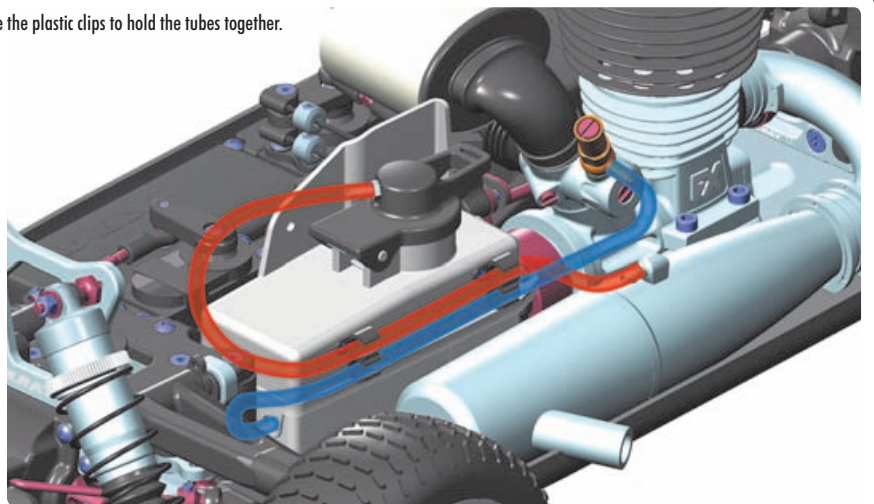

- 1 Before cutting and making holes on the body, put the unpainted body on the chassis to confirm the mounting position and location for holes and cutouts.
- 2 Before painting, wash the inside of the body with mild detergent, and then rinse and dry thoroughly.
- 3 Mask all windows.
- 4 Apply paint masks as appropriate.



- 5 Paint the body using paints formulated for polycarbonate bodies.
- 6 When the paint is dry, remove the masking.
- 7 Carefully cut out the body using appropriate scissors or cutting tools.
- 8 When you have finished cutting, peel off the external protective films.

Body Reamer (HUDY #107600)

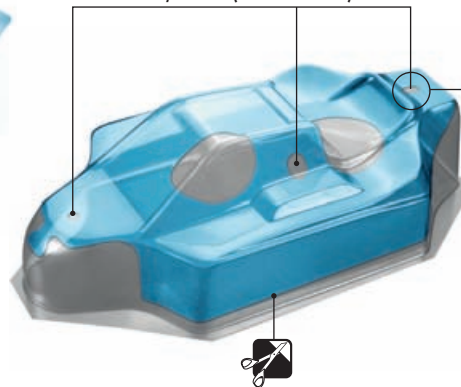

Ensure to make this rear body mount hole oval so in the case of chassis flex after a big jump the body mount will not tear up the hole.

#359712
BODY HIGH-SPEED - LIGHTWEIGHT
OPTION

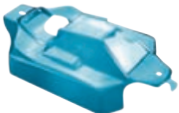

TIP To reinforce the body or to fix broken body use #106280 HUDY BODY FIX



13. FRONT C-HUB SUSPENSION

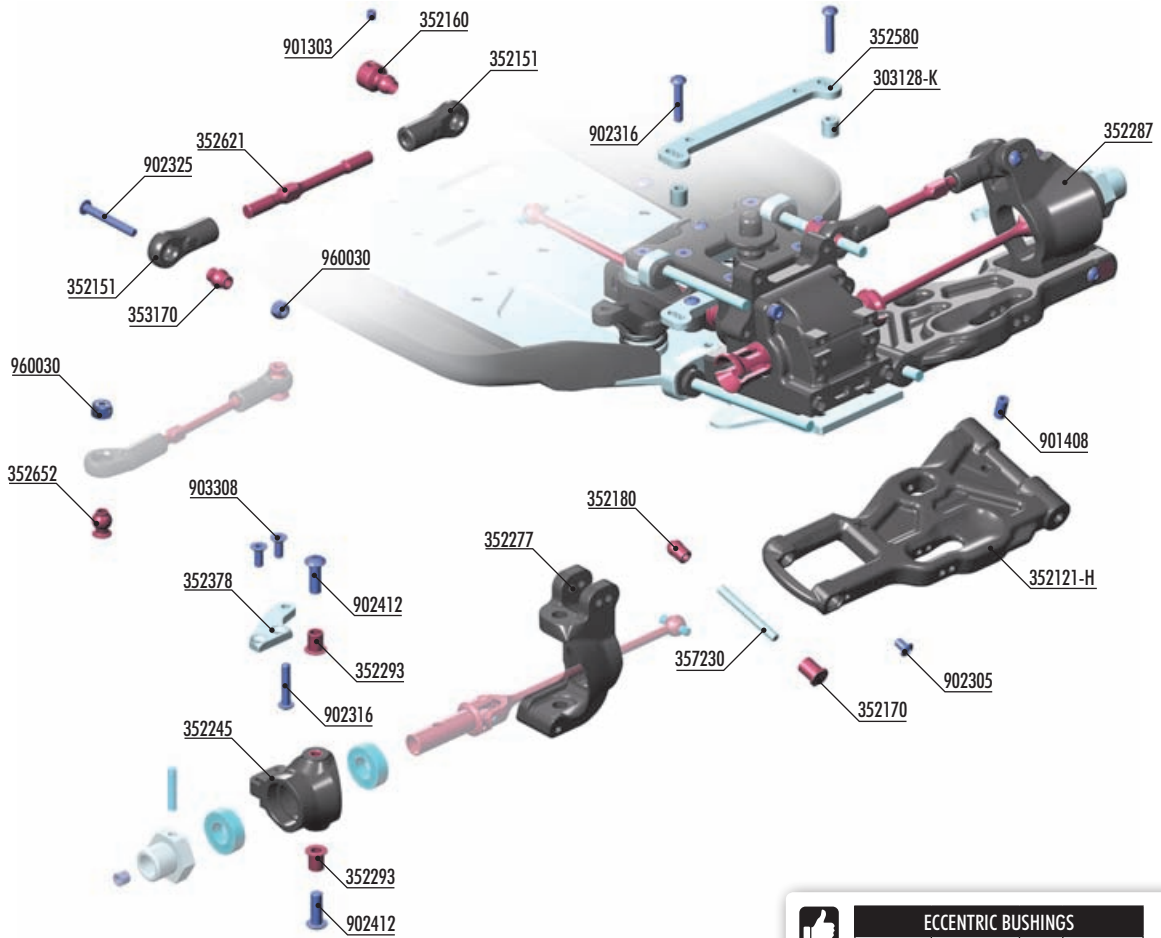

ECCENTRIC BUSHINGS			
OPTION	#352170	0° - STEEL	<input type="radio"/> INCLUDED
	#352171	1° - STEEL	<input type="radio"/> OPTION

BAG

13

- | | | | | | |
|----------|---|--------|--|--------|-------------------------|
| 303128-K | ALU SHIM 3x6x6.0MM - BLACK (10) | 352293 | STEEL BUSHING FOR CASTER BLOCK (2) | 901408 | HEX SCREW SB M4x8 (10) |
| 352121-H | COMPOSITE FRONT LOWER SUSPENSION ARM - HARD | 352378 | ALU STEERING PLATE - SWISS 7075 T6 (L+R) | 902305 | HEX SCREW SH M3x5 (10) |
| 352151 | FRONT UPPER ARM BALL JOINT (2) - V2 | 352580 | ALU STEERING PLATE - SWISS 7075 T6 | 902316 | HEX SCREW SH M3x16 (10) |
| 352160 | STEEL MOUNTING BALL 6.8MM (2) | 352621 | ADJ. TURNBUCKLE M5 L/R 58mm (2) | 902325 | HEX SCREW SH M3x25 (10) |
| 352170 | STEEL ECCENTRIC BUSHING 0° (2) | 352652 | BALL STUD 6.8MM (4) | 902412 | HEX SCREW SH M4x12 (10) |
| 352180 | BALL MOUNT (2) | 353170 | PIVOT BALL 6.8 (4) | 903308 | HEX SCREW SFH M3x8 (10) |
| 352245 | STEERING BLOCK | 357230 | FRONT LOWER OUTER PIVOT PIN (2) | 960030 | NUT M3 (10) |
| 352277 | COMPOSITE CASTER BLOCK 16° RIGHT | | | | |
| 352287 | COMPOSITE CASTER BLOCK 16° LEFT | 901303 | HEX SCREW SB M3x3 (10) | | |

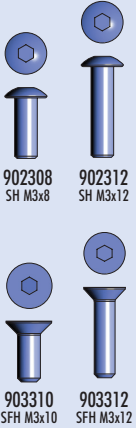

! Use this screws from BAG 7 + BAG 13

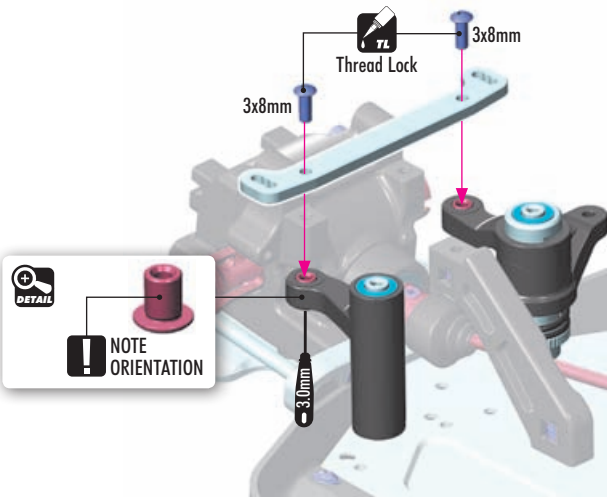

! Use this screws from BAG 7 + BAG 13

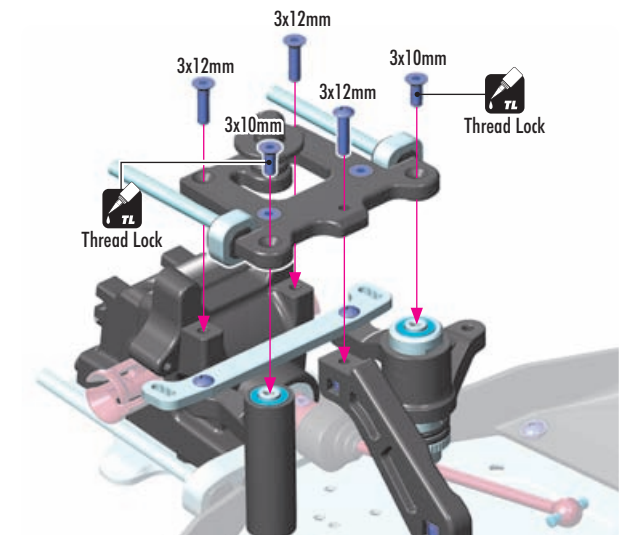

13. FRONT C-HUB SUSPENSION

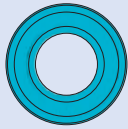

940816
BB 8x16x5



980317
P 3x17



901504
SB M5x4



903308
SFH M3x8

2x 

NOTE ORIENTATION 

Follow the TECH TIP on page 5 for drive shaft pin servicing **TIP**

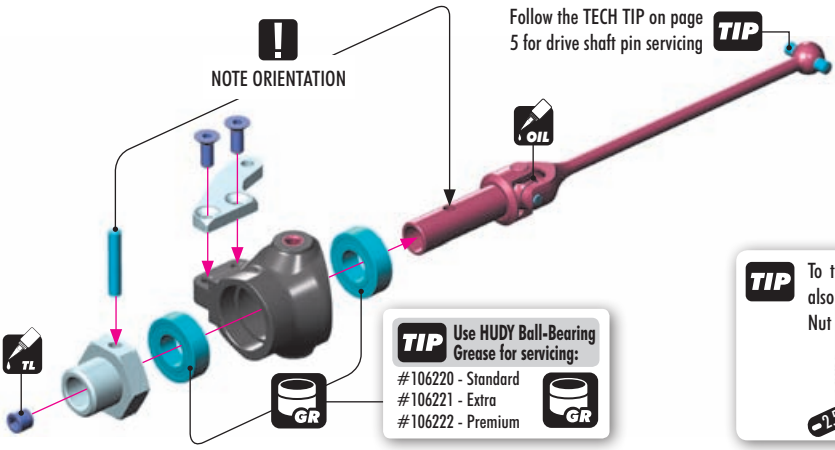

TIP Use HUDY Ball-Bearing Grease for servicing:
#106220 - Standard
#106221 - Extra
#106222 - Premium

TIP To tighten the setscrew you can also use the HUDY 17mm Wheel Nut Tool #107570





902412
SH M4x12

2x 

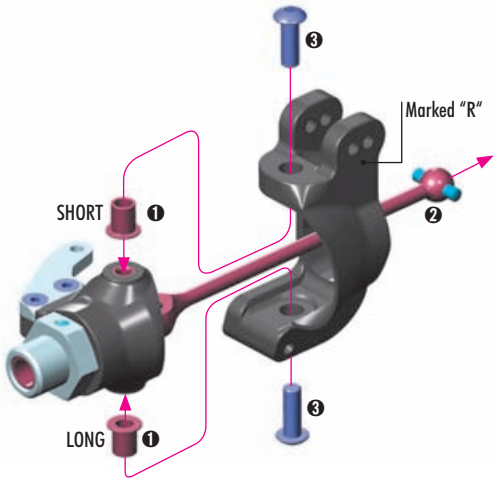

SHORT ①

LONG ①

Marked "R"

2x 

TIP Install the pivot balls with Professional Multi Tool (HUDY #183011)



LEFT THREAD

RIGHT THREAD

32.5mm

LEFT

RIGHT





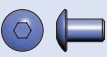

901408
SB M4x8



902305
SH M3x5



902325
SH M3x25



960030
N M3

2x 

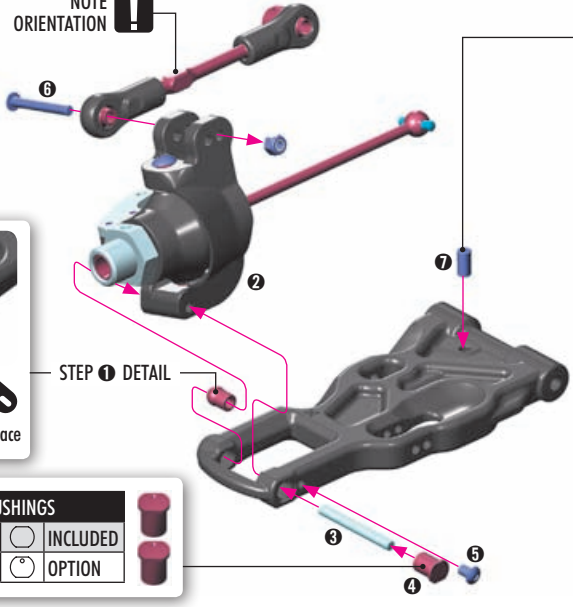

NOTE ORIENTATION 



STEP ① DETAIL



TIP Press pivot ball into arm until it snaps into place

OPTION

ECCENTRIC BUSHINGS			
#352170	0° - STEEL		INCLUDED
#352171	1° - STEEL		OPTION

TOP DOWNSTOP SETTING

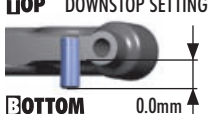
STEP ⑦ DETAIL **BOTTOM** 0.0mm





13. FRONT C-HUB SUSPENSION

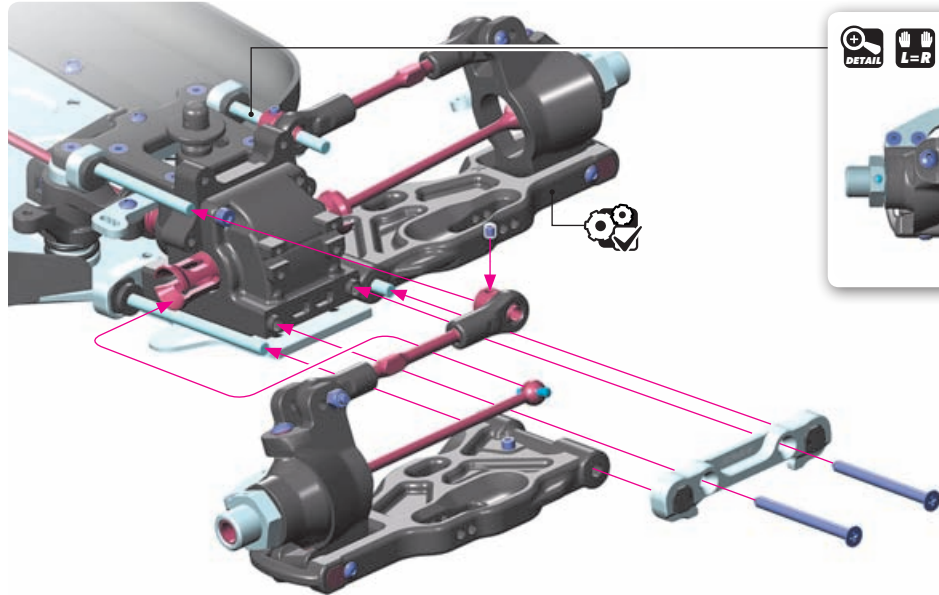

909395
SS 3.5x45

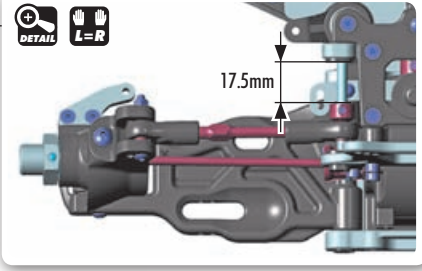



DETAIL L=R
17.5mm

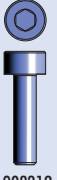

908312
SCH M3x12

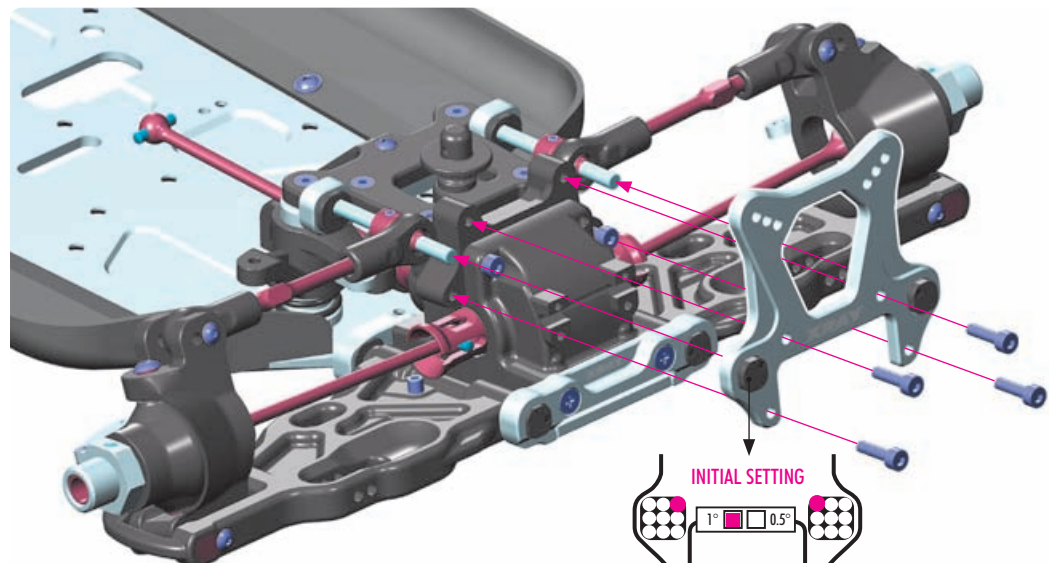

INITIAL SETTING

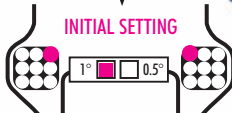





901303
SB M3x3



901305
SB M3x5



902318
SFH M3x18



903308
SFH M3x5



903412
SFH M4x12

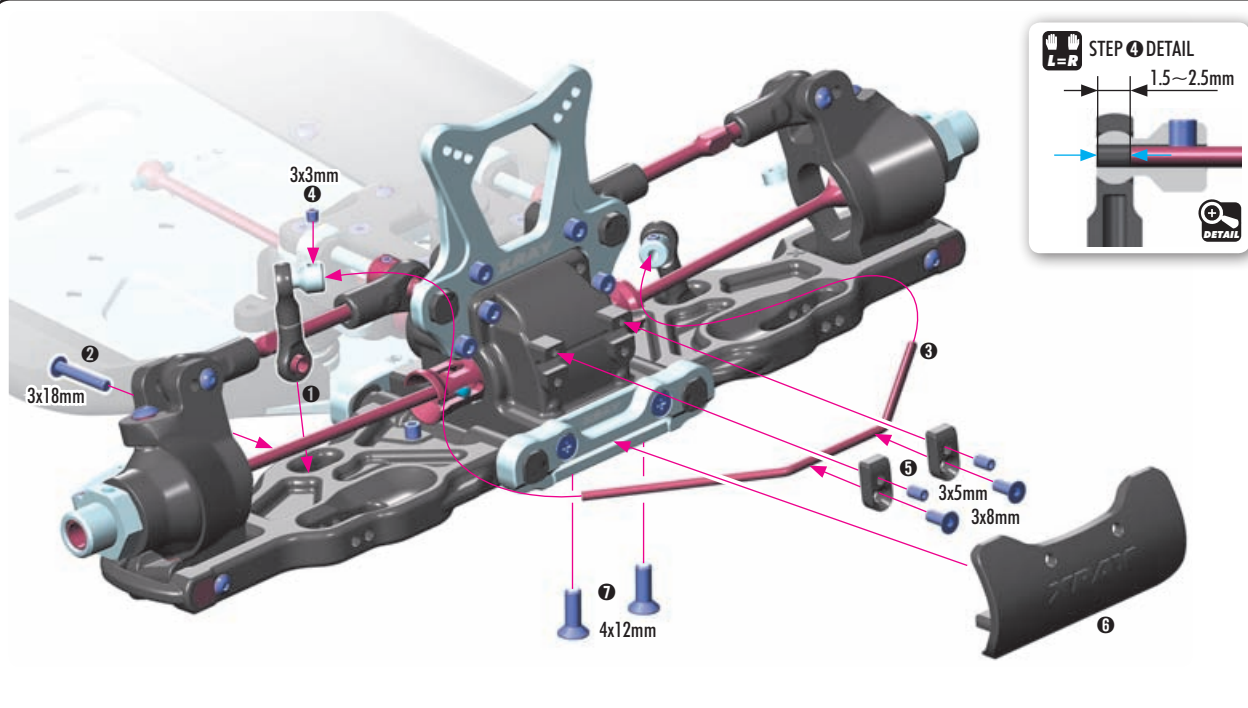

STEP 4 DETAIL L=R

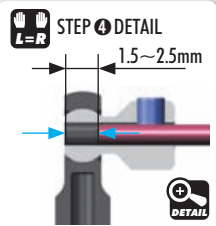

1.5~2.5mm

13. FRONT C-HUB SUSPENSION

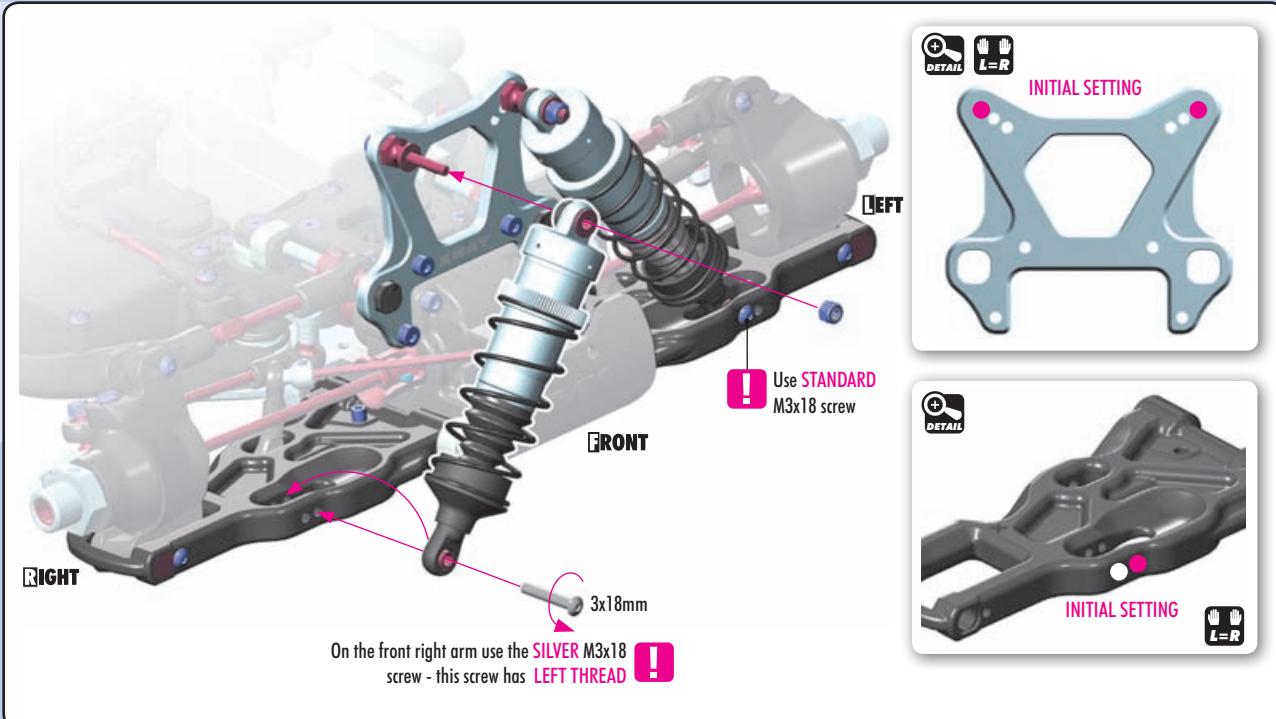
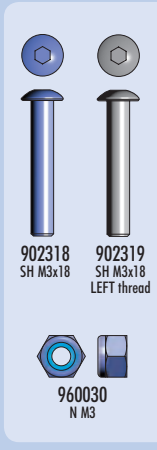
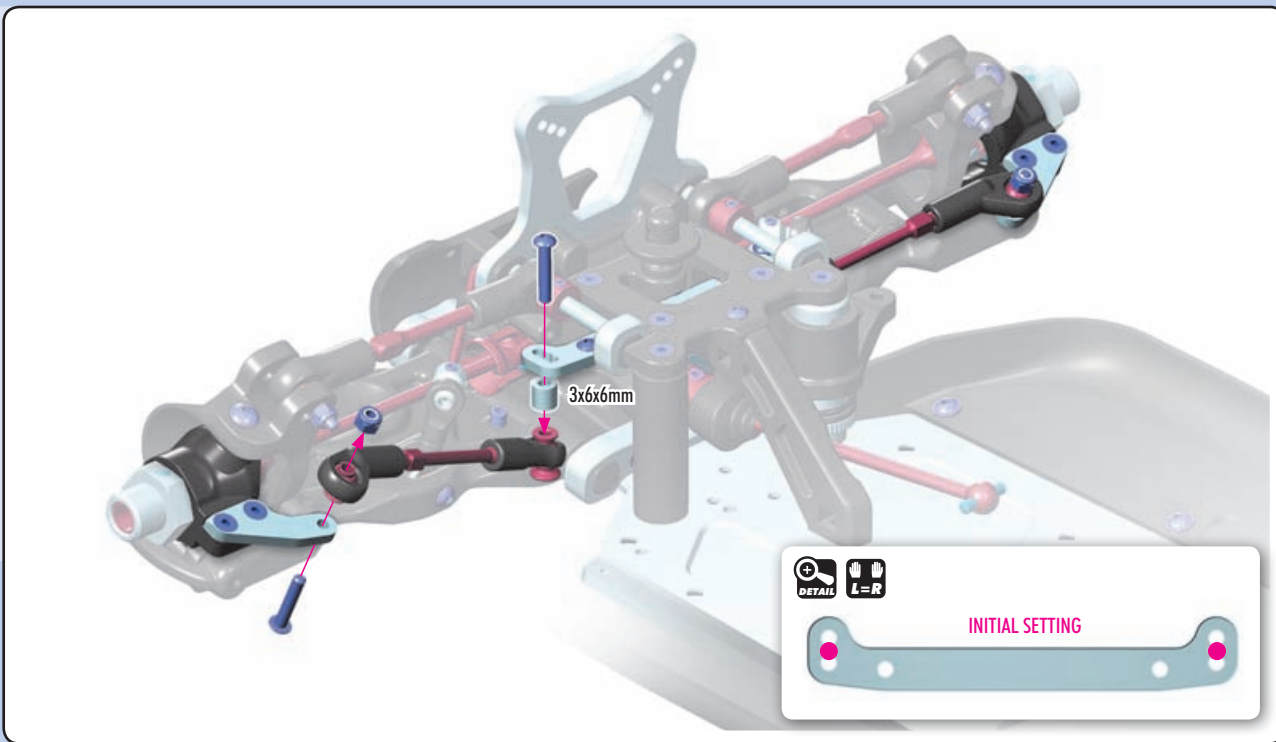
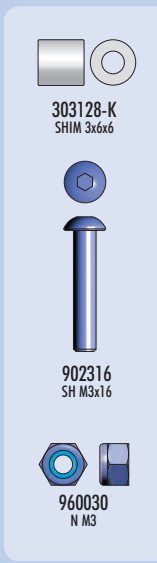
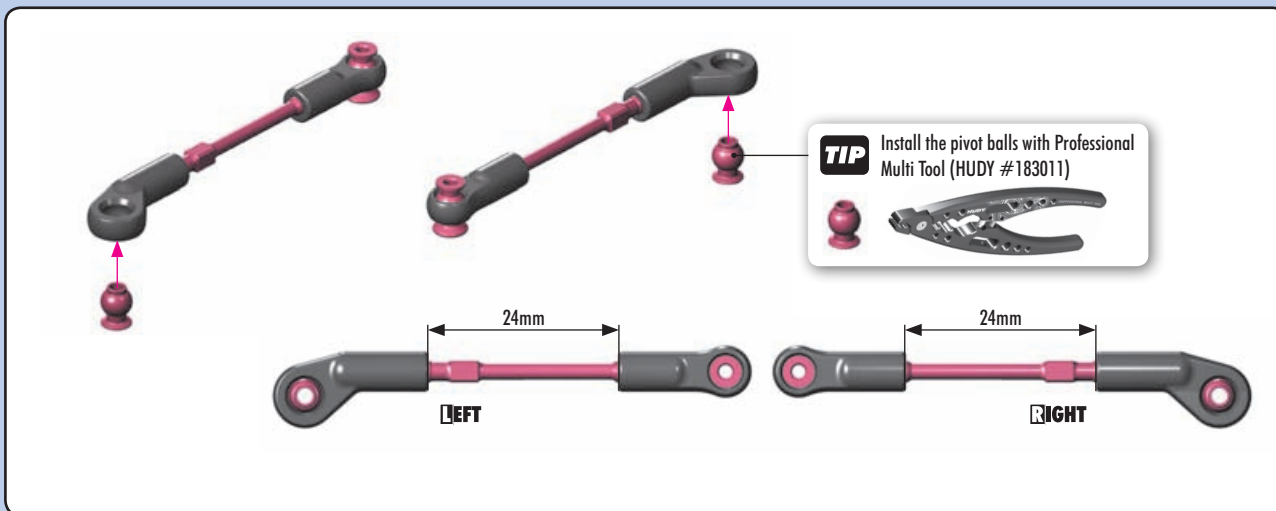

ENGINE OPERATION

PREPARING TO OPERATE THE ENGINE

- Never modify the engine or muffler.
- Confirm the position of needle and idling before running. Be sure to run a new engine smoothly.
- Make sure the air filter is clean and oiled.
- Never run your engine without an air filter. Your engine can be seriously damaged if dirt and debris get inside the engine.
- For proper engine break-in, please refer to the manual that came with the engine.
- The engine may not start or run properly if the air filter is dirty, or choked with sand and dust.
- If the fuel pipe is choked or deteriorates, the engine may not start, and there is danger that fuel will leak out.

STARTING AND RUNNING THE ENGINE

Be sure to observe the following starting process. Failure to do so may cause the model car to start suddenly, which may lead to damage or unexpected accidents.

1. Make sure the transmitter and receiver batteries are fully charged.
2. Make sure that your transmitter and receiver are both on the same frequency. If you have a transmitter with multiple model memory, make sure you have selected the proper profile for your car.
3. Put the car on the starter box and keep the tires from touching the ground.
4. Turn on the transmitter.
5. Turn on the receiver in the car.
6. Make sure the steering servo and engine servos work normally and adjust them correctly.
7. Put fuel in the fuel tank, and close the cap securely.
8. Apply the glow igniter to the engine glowplug.
9. Push the model car onto the starter box to start the engine. (If the engine is new, follow the instruction manual and be sure to break in the new engine properly).
10. When the engine has started, remove the glow igniter.
11. Follow your engine break-in procedure and tune the engine as appropriate.

STOPPING THE ENGINE

Before you stop the engine, try to make sure the engine is at idle first. There are several ways to stop the engine:

- Use a rag to cover the exhaust tip. Be careful! The exhaust is extremely hot so use a thick rag and gloves.
- Pinch the fuel tubing to stop the flow of fuel to the carb. Be careful, this can make the motor run lean which can damage the motor.
- Put your hand over the air filter, or squeeze the air filter element to block the airflow.
- Press an object (such as a screwdriver handle or shoe) against the rotating flywheel to stop its rotation. Be very careful, and do not stick your hand or fingers near the rotating flywheel.

FINISHING OPERATIONS

1. Stop the engine.
2. Turn off the receiver in the car
3. Turn off the transmitter.

MAINTENANCE AFTER RUNNING

Take proper care of your car after running to keep it performing well, and take notice of any damage and wear.

1. Do not leave fuel in the tank.
2. Go outside to drain any residual fuel from the exhaust pipe.
3. Clean the car and remove all sand, mud, and other debris.
4. Use after-run oil in your engine after you have finished running for the day.

SHOCK MAINTENANCE

The most important maintenance task for keeping consistent shock performance is refilling and bleeding them correctly. If built correctly, it will not be necessary to re-build them often. Replacing warped/hard rubber bladders and o-rings, scarred piston rods, or shaved/split/loose composite upper and lower ball joints are also important.

- For club racing, it is recommended to check the shocks for air inside before each race and only re-fill and bleed them if necessary. Before each race day, make sure you take the spring off of each shock, hold it up to your ear, and quickly compress the shock rod fully into the body while listening for any air making a "whistling" or "squishy" sound as it passes through the piston holes. If you hear any air, refill and bleed your shocks. For high-competition racing, it is recommended that the shocks be re-filled and bled before a large event.
- If building or pairing new shocks, always make sure they are the same length using a shock length measuring tool and adjust the lower ball joints as needed.
- If installing new rubber bladders, carefully trim the thin excess rubber from the edges of their lips. Curved body scissors work the best.
- Regularly inspect the amount of dirt on the felt protector in the shocks (if present) and regularly replace with a new one.
- During regular shock operation, oil naturally gets on the shock shaft and drop-by-drop slightly gets out of the shock body. Shocks should be inspected regularly after each race, and oil replaced as required.

BEARING MAINTENANCE

Ball-bearings in an off-road car or truggy must be properly maintained for smooth operation and long lifespan.

Typically, the ball-bearings included in new cars are greased for highest lifespan and as such the drivetrain may not seem to be as free as with lightly-oiled ball-bearings. However, when the car is run the ball-bearings will become more free and the drivetrain will become very efficient.

There are several types of bearings discussed here: bearings which already come greased from the factory, bearings which must be lubricated using the HUDY Bearing Grease, and then there are also bearings in the steering system which need to be lubricated with HUDY Bearing Oil.

The following procedures are recommended to clean all of the bearings in your off-road car or truggy. For high-competition racing, we recommended doing this every 3-4 weeks, or before a major race.

1. Remove the seals on both sides of the bearing (if present). If the seals bend a little and you can see a kink, carefully flatten the kink out by hand.
2. Spray the seals with motor cleaner and blow dry with compressed air.
3. Spray the bearing on both sides with motor cleaner.
4. Spin the bearing while it is still wet to dislodge any particles with the cleaner.
5. Spray the bearing on both sides again.
6. Blow both sides of the bearing dry with compressed air to make sure particles come out.
7. Hold the inner part of the bearing with my left thumb/forefinger and spin it to make sure it spins free without any abnormal vibrations or sounds.
8. Place one drop of bearing oil into each side of the bearing.
9. Replace both seals at the same time by lining them up on each side of the bearing and lightly pressing them in all the way around the bearings circumference with your thumb and forefinger. Do not press too hard or use any type of tool, such as a wrench tip, to push the blue seals in as they will push in too far, bend and cause drag.

If you spin test the bearing after you have re-oiled and sealed it, it will not spin freely for an extended period of time. The lightest of oils may allow it to spin for 1-2 seconds. This is normal and once you have mounted the bearings in the car again, the drive train will spin freely.

Make sure you use a motor cleaner that does not leave a residue after it dries as this may cause drag and wear in the bearings.

CLUTCH BEARINGS

To prolong the lifespan of the clutch bearings, they must be regularly cleaned and lubricated (preferably after each run) using a high-quality grease such as HUDY Bearing Grease. However, after some time the clutch bearings must be replaced with new ones.

RECOMMENDED PRODUCTS

- Use HUDY Bearing Grease to regularly lubricate grease-bearing ball-bearings.
- Use HUDY Bearing Oil to lubricate the bearings of the steering system.
- Use HUDY Bearing Grease to regularly lubricate the clutch bearings.

HUDY #106213



HUDY #106220



HUDY #106222



HUDY #106221



HUDY #106230



THROTTLE LINKAGE ADJUSTMENT

NEUTRAL (IDLE)

ADJUST INDIVIDUAL LINKAGES SEPARATELY TO AVOID INTERFERING WITH THE OPERATION OF THE OTHERS

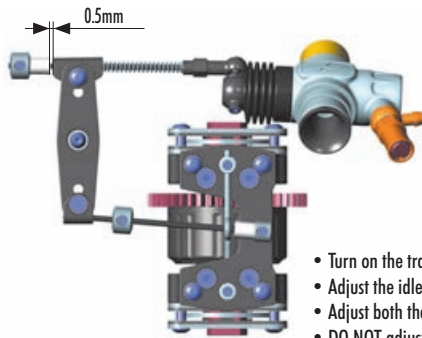

- Turn on the transmitter and receiver and set the engine control servo trim to the neutral position.
- Adjust the idle adjustment screw on the carburetor to open approx. 1mm.
- Adjust both the throttle linkage and brake linkages accordingly.
- DO NOT adjust the linkage with the engine running.

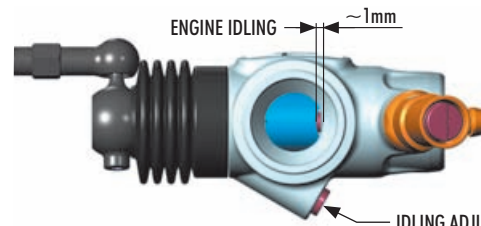

ENGINE IDLING ~1mm
IDLING ADJUSTMENT SCREW.
Use to adjust the idle setting of the carburetor. Do not allow carburetor to close to less than 1mm.

FULL THROTTLE

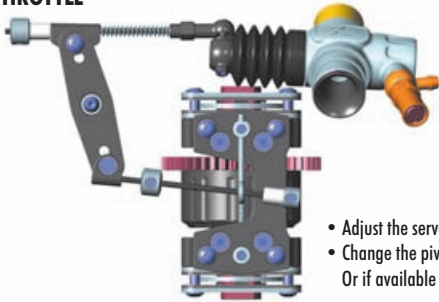

- Adjust the servo-horn mounting position for the carburetor to open fully.
- Change the pivot mounting position on the servo horn in case the carburetor is not opening fully or if it is opening excessively. Or if available on the transmitter, adjust the throttle high end point.

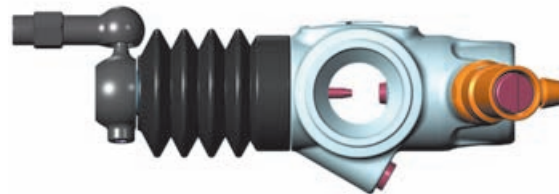

BRAKE

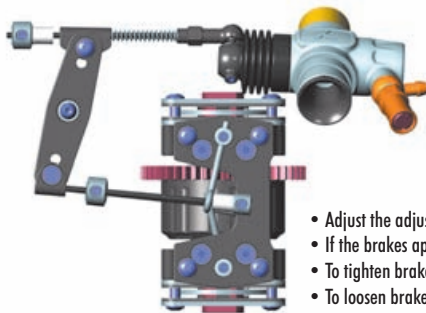

- Adjust the adjustable collars so the brakes work smoothly.
- If the brakes apply too much or not enough, adjust the adjustable collars accordingly. Or if available on the transmitter, adjust the brake endpoint.
- To tighten brakes, turn collar to thread brake rod INTO pivot.
- To loosen brakes, turn collar to thread brake rod OUT of pivot.

ENGINE IDLING cca 1mm

BRAKE ADJUSTING KNOBS:
Upper linkage - rear brake
Lower linkage - front brake

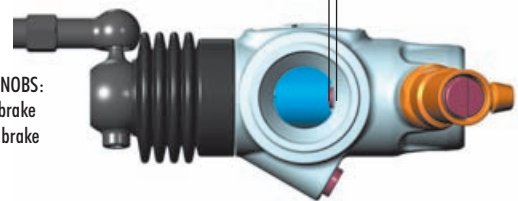

TROUBLESHOOTING GUIDE

PROBLEM	CAUSE	SOLUTION
ENGINE DOES NOT START	<ul style="list-style-type: none"> • Fuel tank is empty or carburetor is not primed • Bad glowplug or dead glowdriver battery • Fuel lines, fuel filter, air cleaner, or muffler is clogged • Engine is flooded due to over-priming • Carburetor is not adjusted properly • Throttle servo linkage not adjusted properly 	<ul style="list-style-type: none"> • Fill fuel tank with fuel and prime • Replace glowplug or recharge/replace glowdriver battery • Clean or replace clogged part(s) • Remove glowplug, turn car over to discharge fuel from cylinder. Test glowplug and replace if defective • Set idle and main/slow needle adjusting screw to standard starting position • Move throttle servo to neutral position and re-adjust linkage(s)
ENGINE STARTS BUT THEN STALLS	<ul style="list-style-type: none"> • Fuel tank is empty • Fuel lines, fuel filter, air cleaner, or muffler is clogged • Carburetor is not adjusted properly • Engine has overheated 	<ul style="list-style-type: none"> • Fill fuel tank with fuel • Clean or replace clogged part(s) • Re-adjust idle and main/slow needle adjusting screw • Allow engine to thoroughly cool down and open main needle adjusting screw 30° turn richer (CCW)
BAD REACTION AND RESPONSE FROM ENGINE	<ul style="list-style-type: none"> • Carburetor is not adjusted properly • Fuel lines, fuel filter, air cleaner, or muffler is clogged • Low fuel pressure from muffler 	<ul style="list-style-type: none"> • Re-adjust main/slow needle adjusting screw • Clean or replace clogged part(s) • Properly install pressure line between muffler and fuel tank
CAR IS HARD TO CONTROL	<ul style="list-style-type: none"> • Weak transmitter and/or receiver batteries • Low reception from radio antennas • Servo linkages not adjusted properly 	<ul style="list-style-type: none"> • Recharge or replace batteries • Fully extend transmitter and receiver antennas • Move servo to neutral then re-adjust linkage(s)
STEERING DOES NOT WORK PROPERLY	<ul style="list-style-type: none"> • Weak transmitter and/or receiver batteries • Bent linkages or driveshafts • Loose steering components • Drivetrain damage 	<ul style="list-style-type: none"> • Recharge or replace batteries • Check tightness of steering components and tighten if necessary • Replace damaged parts
HANDLING PROBLEMS	<ul style="list-style-type: none"> • Shocks are not working properly • Suspension is binding • Improper tires 	<ul style="list-style-type: none"> • Rebuild the shocks and replace worn or broken parts • Make sure suspension moves freely. Replace worn or broken parts • Use different tires
STEERING FEELS SLUGGISH OR VAGUE	<ul style="list-style-type: none"> • Suspension is binding • Damaged steering servo 	<ul style="list-style-type: none"> • Make sure suspension moves freely, and replace worn or broken parts • Check the steering servo for damage and wear, and replace/repair if necessary
THE CAR DOES NOT DRIVE STRAIGHT	<ul style="list-style-type: none"> • Suspension is binding • Steering trim is off-center • Wheels are loose • Damaged steering servo 	<ul style="list-style-type: none"> • Make sure suspension moves freely, and replace worn or broken parts • Adjust steering trim until car drives straight • Check the make sure the wheel nuts are properly tightened • Check the steering servo for damage and wear, and replace/repair if necessary

www.teamxray.com

XRAY EUROPE

XRAY, K VÝSTAVISKU 6992, 91101 TRENCIN, SLOVAKIA, EUROPE
PHONE: +421-32-740 11 00, FAX: +421-32-740 11 09, info@teamxray.com

XRAY USA

RC AMERICA, 2030 Century Center Blvd #15, Irving, TX 75062, USA
PHONE: 214-744-2400, FAX: 214-744-2401, xray@rcamerica.com



/TeamXray



/TeamXray



/TeamXray



/TeamXrayRC



/XrayRacing



/XrayRacing