

# Enduro Sport Edition Chassis

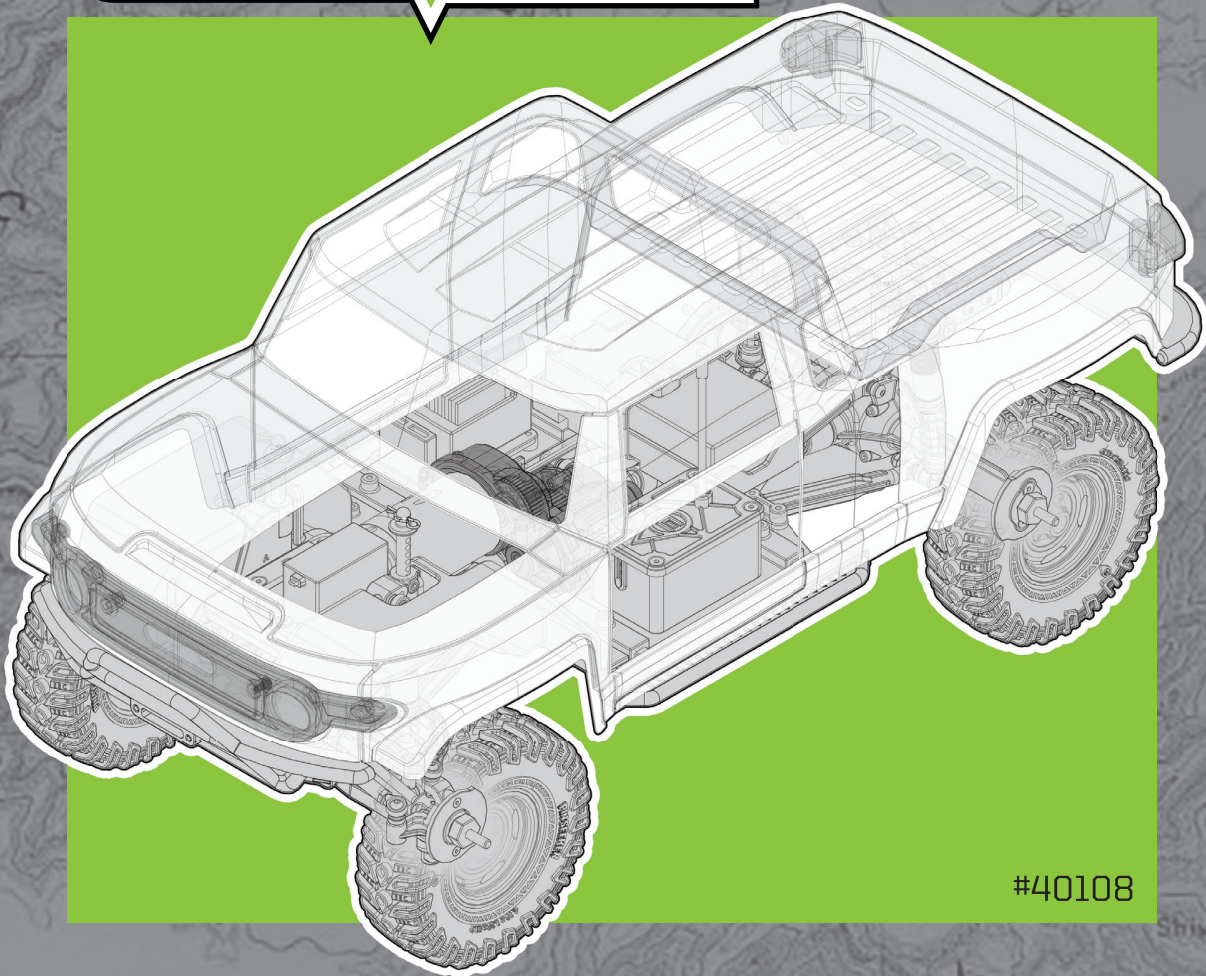

#40108

**UTRON SE**

## REPAIR MANUAL

- Enduro Chassis
- Sport Edition
- Independent Front Suspension
- Stealth-XF Transmission
- Four-Wheel-Drive





**Associated Electrics, Inc.**  
**21062 Bake Parkway**  
**Lake Forest, CA 92630**

**Customer Service**  
**Tel: 949.544.7500**  
**Fax: 949.544.7501**

Follow Us On Social Media



ElementRC



@Element\_RC

[www.ElementRC.com](http://www.ElementRC.com)

AE is a Registered Trademark of Associated Electrics, Inc.

TEAM ASSOCIATED is a Registered Trademark of Associated Electrics, Inc.

REEDY is a Registered Trademark of Associated Electrics, Inc.

FACTORY TEAM is a Registered Trademark of Associated Electrics, Inc.

ELEMENT™ is a Trademark of Associated Electrics, Inc.

AREA 51 is a Registered Trademark of Associated Electrics, Inc.

STEALTH is a Registered Trademark of Associated Electrics, Inc.

GREEN SLIME is a Registered Trademark of Associated Electrics, Inc.

## ITEMS NEEDED

The following items are required to build or maintain your Enduro Trail Truck.

- 1.5mm Allen Wrench (#1500)
- 2mm Allen Wrench (#1501)
- 2.5mm Allen Wrench (#1503)
- Pliers
- Long Nose Pliers
- 5.5mm Nut Driver (#1507)
- 7mm Nut Driver (#1508)

## OTHER HELPFUL ITEMS

The following items aren't required, but will aid in the building and maintaining of your Enduro Trail Truck.

- Threadlock (#1596)
- Green Slime (#1105)
- Black Grease (#6588)

**Your journey begins here.**



## INTRODUCTION

Thank you for purchasing this Element RC product. This assembly manual contains instructions and tips for building and maintaining your new Enduro chassis. Please take a moment to read through this manual to help familiarize yourself with these steps. We are continually changing and improving our designs; therefore, actual parts may appear slightly different than in the illustrations. New parts will be noted on supplementary sheets located in the appropriate parts bags.

## FEATURES

- Front injection molded inner fenders
- New IFS2 SUSPENSION
- 1.9" bead lock wheels
- 1.9" x 4.19" PinSeeker Tires
- High clearance front and rear bumpers
- 12.8" wheelbase
- 1-piece polycarbonate UTRON SE body
- Adjustable front and rear bumper mounts with integrated winch line routing
- Adjustable width rock sliders

### IFS2 FEATURES:

- 0 bumper steer suspension design
- Increased suspension travel
- Linear / slider steering rack
- Improved clearance and approach angles on front suspension arms and skid plates
- Scale upper and lower control arms
- Suspension arms are symmetric left to right
- Lower pivot ball mounting has been flipped for increased ground clearance
- More traditional steering servo mounting location
- Servo winch mount location

- Steel servo horn
- Heavy duty steel suspension balls
- Metal ring and pinion gears
- 12mm wheel hexes
- Universal front drive axles
- Larger 5x12x4mm input bearing / bushing cavity
- 45° steering throw

### ADDITIONAL FEATURES:

- 90mm shock length
- Stamped steel high clearance frame rails
- Enclosed receiver box
- ESC tray for cleaner wiring
- Two battery boxes
- Aluminum motor plate
- Adjustable body posts
- Optimized ball cups and links for more fluid axle articulation
- POM-filled injection molded pivot balls
- Adjustable rear shock mount positions for tuning wheelbase and shock angles
- Telescopic driveshafts front and rear
- One-piece rear axle design
- Plastic StealthXF upper transmission gears
- Machined steel top shaft

**UPDATED AXLES:** New axles with larger input bushings (upgradable to bearings) handle higher loads. New diff covers feature the ability to add weights on the inside to maintain a scale look, and faux disk brakes with calipers add even more scale details.







**THREADED SHOCK BODIES AND MINI SPRINGS:** Just as smooth and reliable as our aluminum shocks, these durable plastic shocks feature caps with a bleeder screw for easy airless bleeding and mini springs for a more scale appearance and to keep the weight low..

**STEALTH® XF GEARBOX WITH FORWARD MOTOR MOUNT:** At the heart of the Enduro is our all-new Stealth® XF gearbox. The new design moves the motor forward to help keep the weight over the front wheels. This new design comes stock with a one-to-one ratio, but still maintains the ability to adjust the rear drive ratio independently from the front with the use of our optional Factory Team gears. Sold separately, these gears allow the transmission to overdrive the front a mild 5.7% or a more aggressive 11.83%.

















**HARDWARE 1:1 SCALE VIEW**

HARDWARE USED WITH OPTIONAL REPLACEMENT PART NUMBERS





**FLAT HEAD SCREWS (FHCS)**

	2.5x10mm (31350)
	2.5x14mm (41077)
	3x6mm (31541)
	3x8mm (25201)
	3x10mm (25202)
	3x12mm (25203)
	3x14mm (89208)









**BUTTON HEAD SCREWS (BHCS)**

	2x3mm (31509)
	2.6x10mm, SelfTapping (41088)
	3x4mm (91158)
	3x5mm (31530)
	3x6mm (31531)
	3x8mm (31532)
	3x10mm (25211)
	3x12mm (89202)
	3x14mm (25187)
	3x16mm (89203)
	3x18mm (2308)
	3x20mm (25188)
	3x22mm (25189)
	3x24mm (89204)
	3x26mm (89205)
	3x28mm (41078)

**LP SOCKET HEAD SCREWS (LP SHCS)**

	3x6mm (41089)
	3x10mm (41090)
	3x16mm (41092)
	3x20mm (41091)



**SOCKET HEAD SCREWS (SHCS)**

	2x5mm (31511)
	2x8mm (7187)
	2.5x6mm (41079)
	2.5x10mm (41087)
	2.5x14mm (71032)
	2.5x16mm (41086)
	2.6x10mm (42332)
	3x6mm (41089)



**SET SCREWS**

	3x3mm (25225)
	3x16mm (4689)
	4x16mm (4677)

**PIVOT BALLS**

	Pivot Ball, Short (42041)
	Pivot Ball, Long, Upper Shock (42041)

**LOCK NUTS**

	M3 Locknuts (25215) Aluminum (31550)
	M4 Locknut W/Flange (25391)

**BEARINGS**

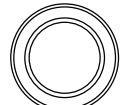



	4x8x3mm (91568)
	5x10x4mm (91560)
	5x12x4mm (91567)
	7x14x3.5mm (91479)
	10x15x4mm (91563)

**SHIMS AND WASHERS**

	3x7mmx1mm (42260)
	3x7mmx2mm (42260)
	3x7x3mm (42260)
	3x7x5mm (42260)
	3x7x7mm (42260)

	Drive Gear Shim (42027)
---	-------------------------

**MISC. SCREWS**

	Shoulder Screw 3x4x10mm (42070)
	Screw Pin (42022)
	Pin 2x9mm (31872)
	Pin 2x11mm (42019)

## TABLE OF CONTENTS

4/17/2023

<b>01</b>	COVER	<b>12</b>	DRIVESHAFTS BUILD
<b>02</b>	INTRODUCTION	<b>13</b>	SHOCKS BUILD
<b>03</b>	1:1 HARDWARE "FOLD OUT"	<b>14</b>	BUMPERS BUILD
<b>04</b>	TABLE OF CONTENTS	<b>15</b>	WHEELS/TIRES BUILD
<b>05</b>	Stealth XF BUILD	<b>15</b>	BODY BUILD
<b>06</b>	Chassis BUILD	<b>16</b>	OPTIONAL GEARBOX BUILD
<b>11</b>	REAR AXLES BUILD	<b>17</b>	TRAIL TIPS
<b>12</b>	LINKS BUILD	<b>18</b>	BACK COVER

## USING THIS MANUAL



This symbol indicates a special note or instruction in the manual.

**x2**

This symbol indicates the number of the same part that is required.



This symbol indicates the order within a step to assemble parts.



This symbol indicates there are optional FT parts available



This symbol indicates a Trail Tip.



This symbol indicates where Black Grease should be applied.



This symbol indicates where Green Slime can be applied. \*not included

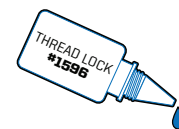

This symbol indicates where Thread Lock Adhesive should be applied. \*not included



This symbol indicates where Shock Fluid should be applied.



There is a 1:1 hardware foldout page in the front of the manual. To check the size of a part, line up your hardware with the correct drawing until you find the exact size. Each part in the foldout has a number assigned to it for ordering replacement parts.

**GATE 01** STEALTH XF BUILD:

**42316** x1 Stealth XF Drive Gear, 52T

**42320** x1 Stealth XF

**31350** x4 2.5x10mm FHCS

**42321** x2 10x15x4mm Bushing

**91563** x2 10x15x4mm Bearing

**42025** x1 Idler Shaft Pin 2x9mm

**42025** x1 Idler Shaft

**42316** x1 Stealth XF Idler Gear, 28T

**42321** x2 5x10x4mm Bushing

**91560** x2 5x10x4mm Bearing

**42315** x1 Stealth XF Case

**42319** x1 Top Shaft

**42321** x2 5x10x4mm Bushing

**91560** x2 5x10x4mm Bearing

**42315** x1 Stealth XF Case

**FACTORY TEAM**

**BLACK GREASE** #32000

**GATE 02** STEALTH XF BUILD:

**42315** x1 Stealth XF Case

**42315** x1 Stealth XF Case

**42332** x6 2.6x10mm SHCS, Silver

**41078** x2 3x28mm BHCS

**89202** x3 3x12mm BHCS

**31350** x3 2.5x10mm FHCS

**NOTE:** Do not overtighten the 3x28mm BHCS

**FACTORY TEAM**

**GATE 03** STEALTH XF BUILD:

**42316** x1 Stealth XF Spur Gear, 50T Plastic

**42318** x2 Stealth XF Slipper Plate

**25391** x1 FT M4 Locknut

**42318** x3 Conical Washer

**42318** x2 Stealth XF Slipper Pad

**42333** FT Slipper Lockout

**42315** x1 Stealth XF Case

**42332** x6 2.6x10mm SHCS, Silver

**FACTORY TEAM**

## GATE 04 STEALTH XF BUILD:

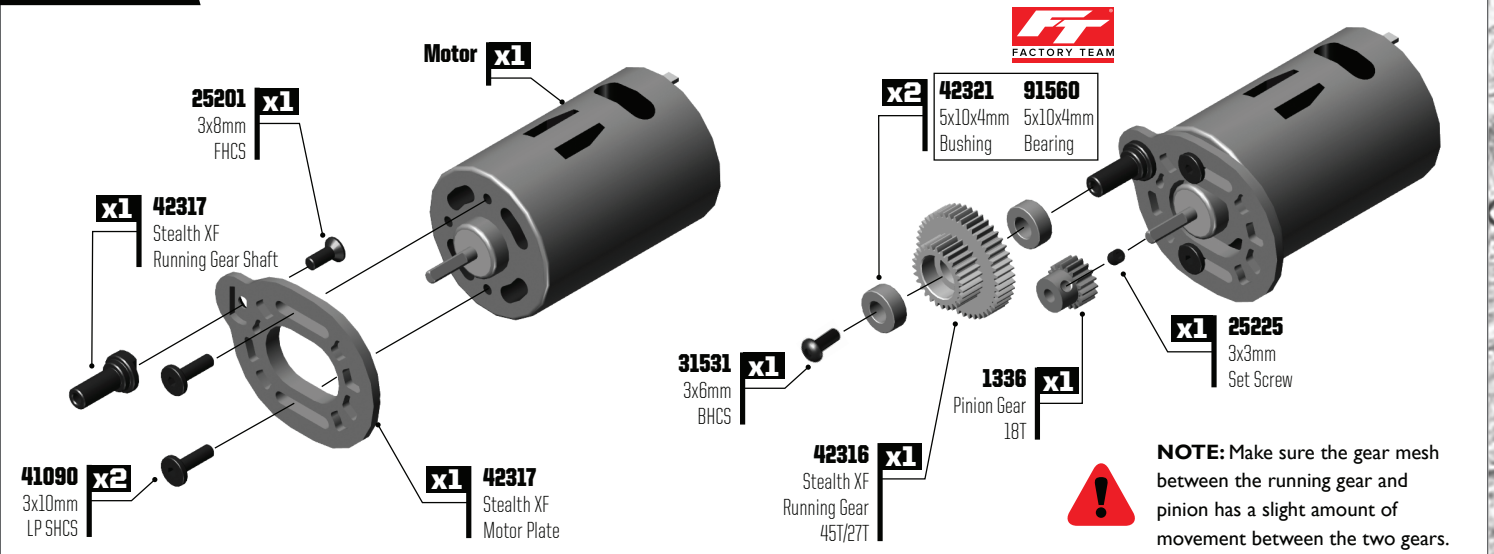

## GATE 05 / 01 STEALTH XF BUILD: / CHASSIS BUILD:

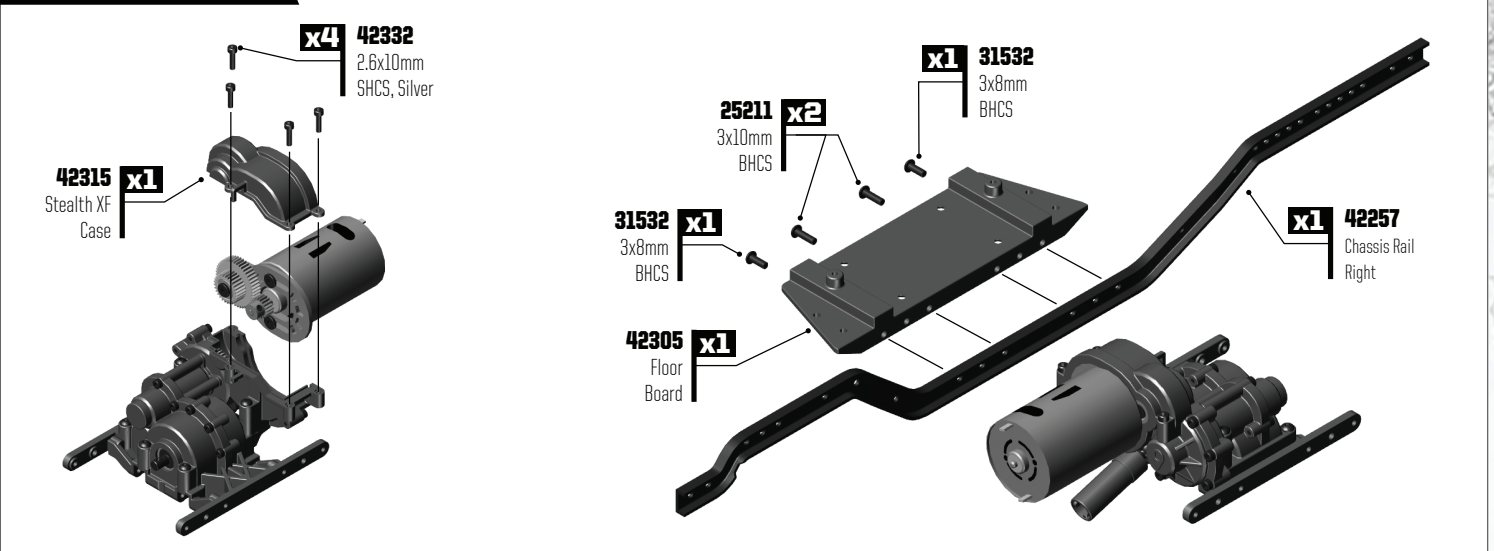

## GATE 02 CHASSIS BUILD:

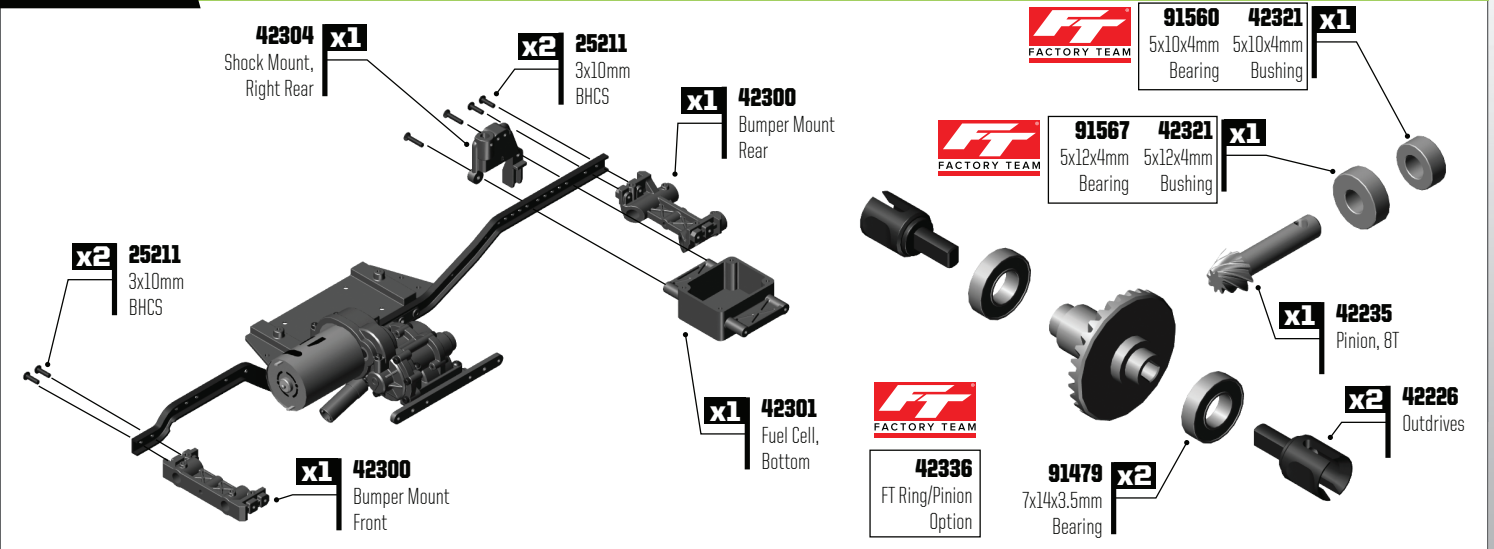

## GATE 03 CHASSIS BUILD:

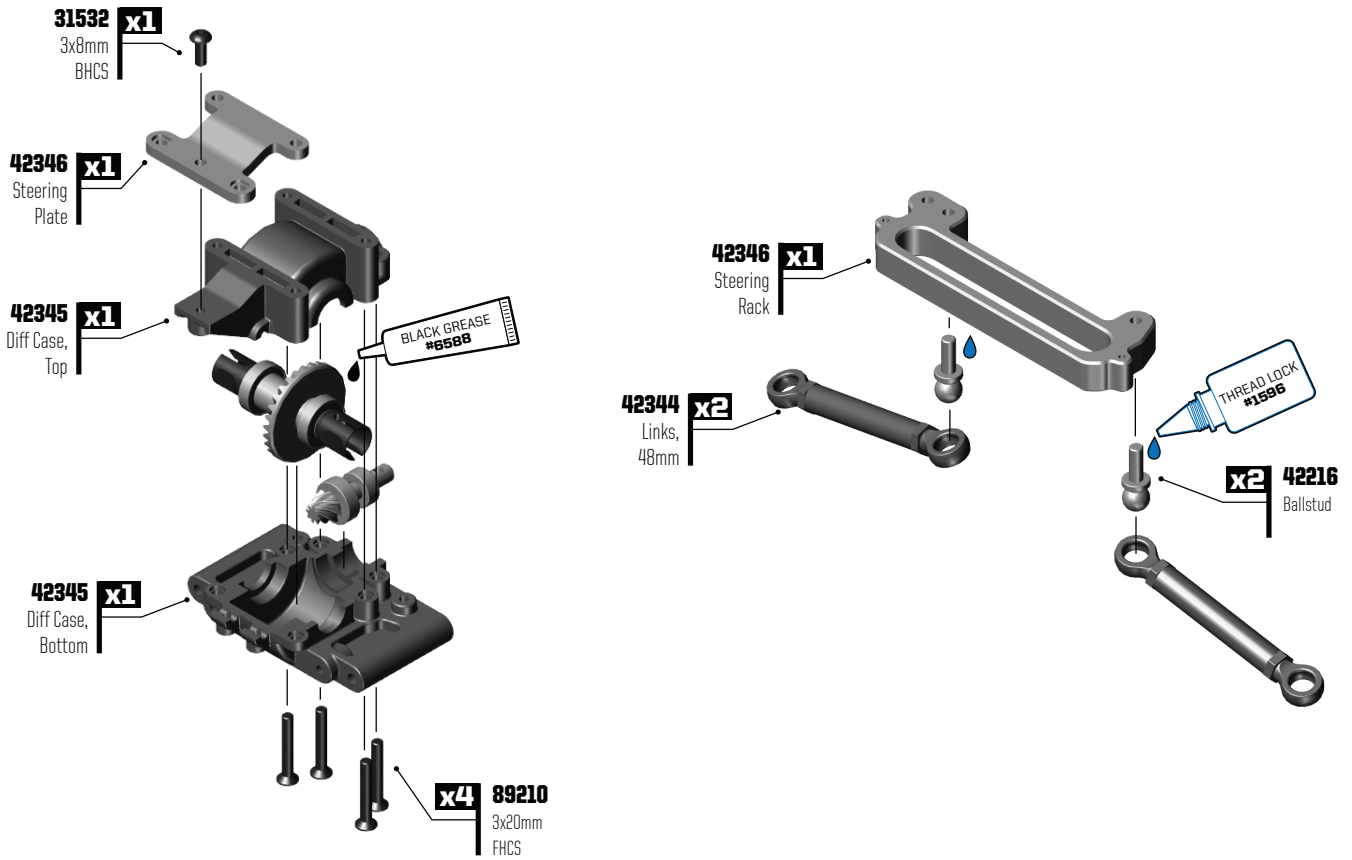

## GATE 04 CHASSIS BUILD:

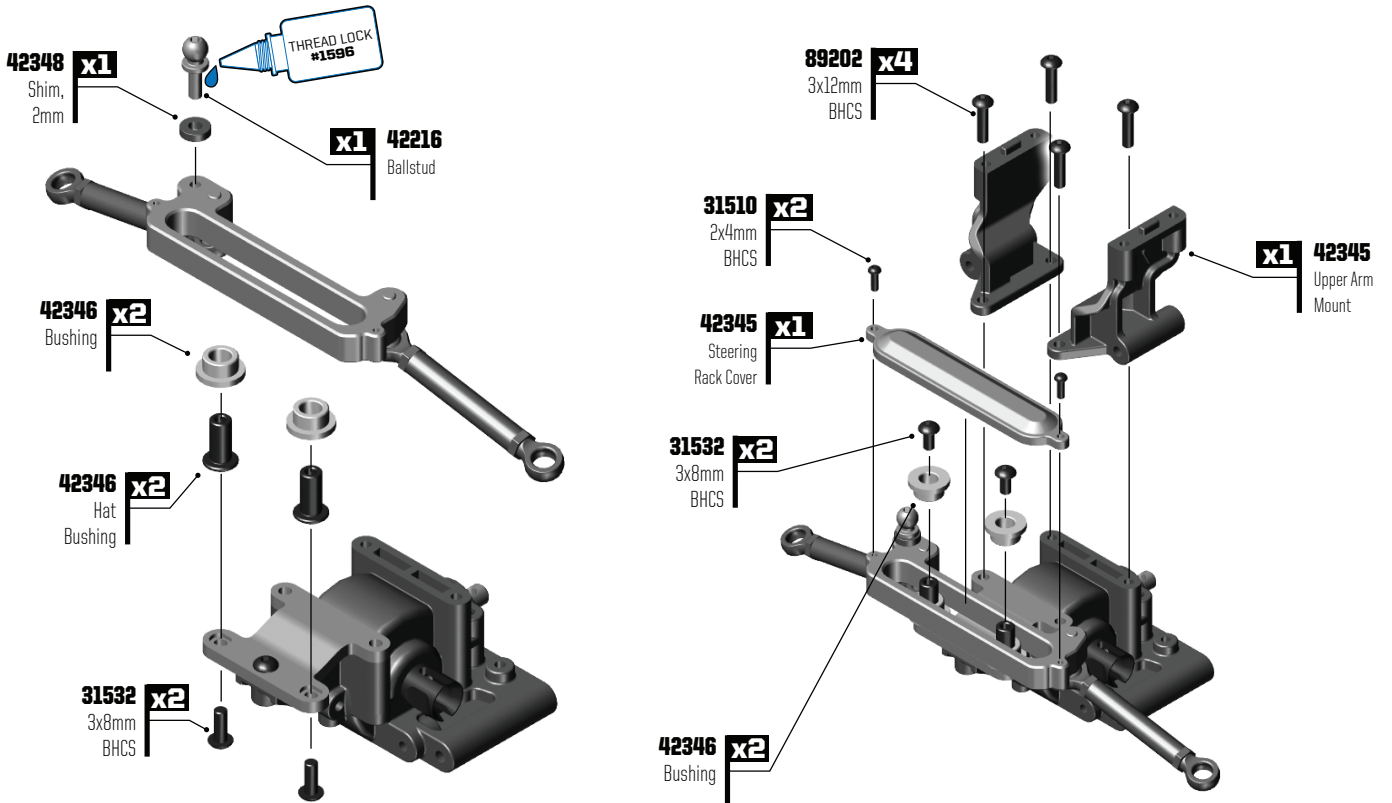

## GATE 05 CHASSIS BUILD:

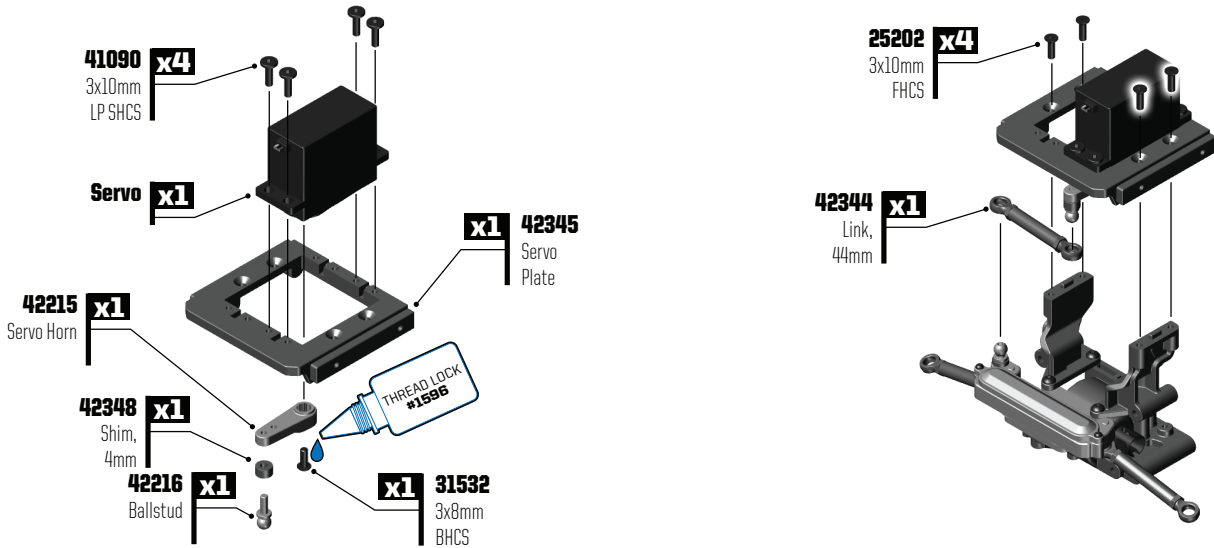

## GATE 06 CHASSIS BUILD:

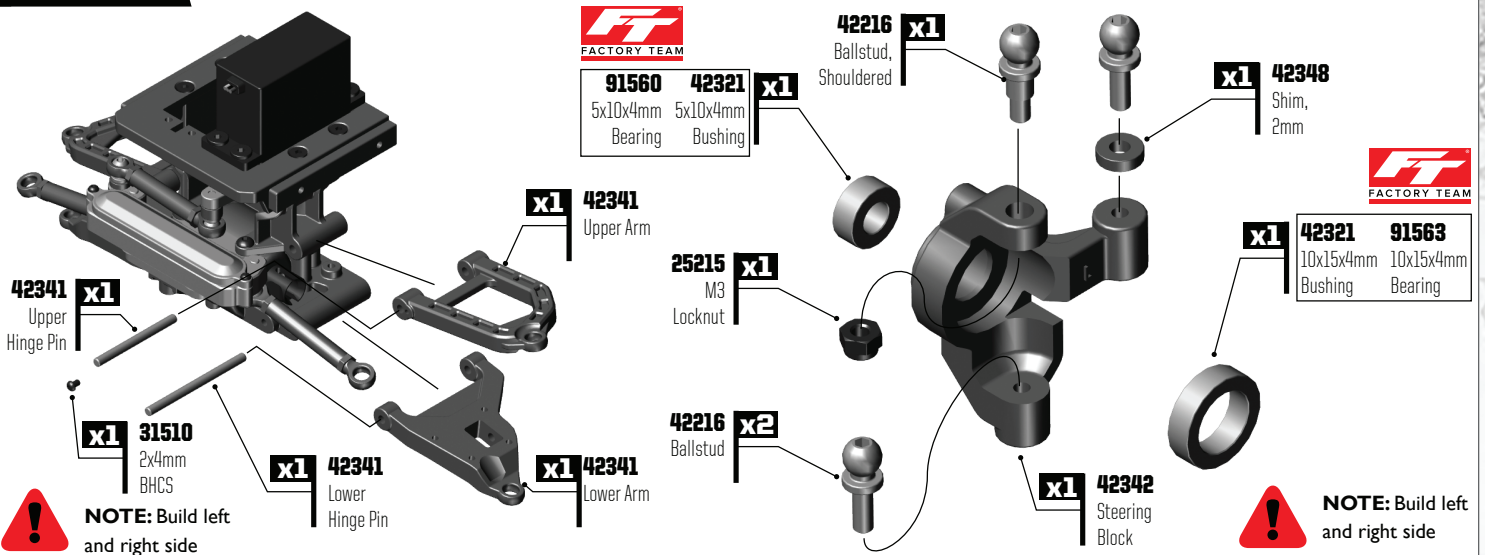

## GATE 07 CHASSIS BUILD:

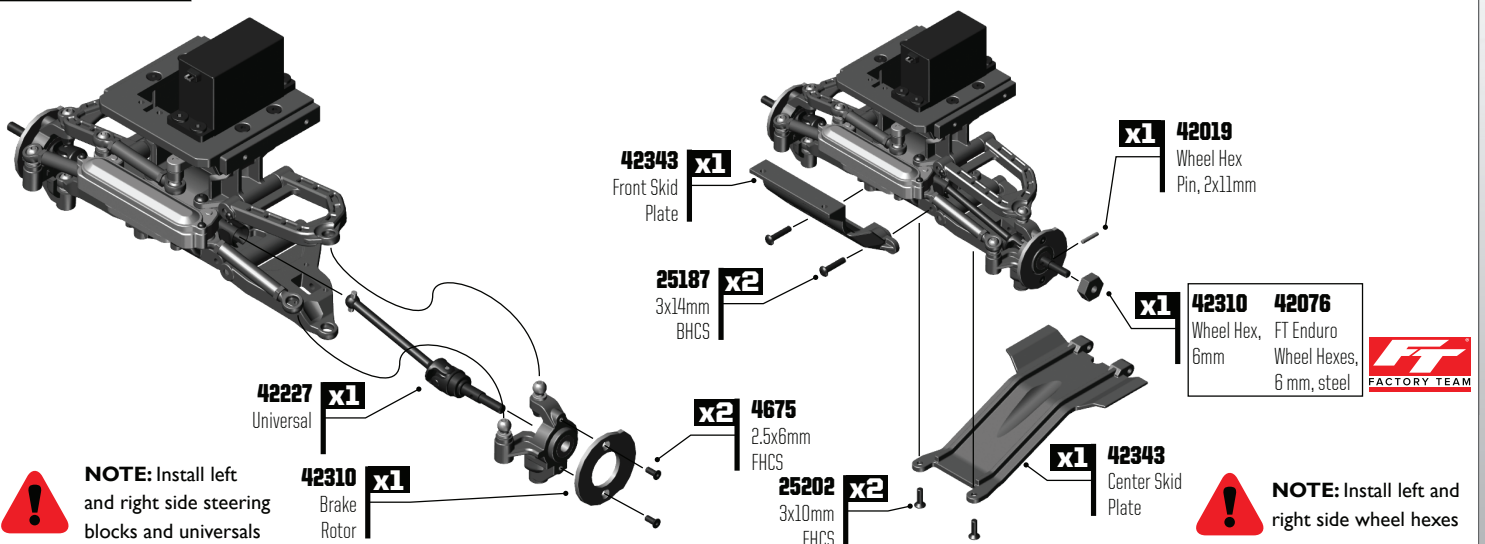



### GATE 08 CHASSIS BUILD:

- x2** 42021 Pin, 2x11mm
- x1** 42314 Drive Shaft, Female (33mm, 42mm)
- x2** 31532 3x8mm BHCS
- 42021 Drive Shaft, Male, CVA
- x2** 42021 Drive Shaft, Female, CVA
- x2** 42021 Drive Shaft Barrel
- x1** 42314 Pin Retainer, Short
- x1** 42314 Drive Shaft, Male (46mm, 60mm)
- x1** 42020 Gearbox Side
- x1** 42020 Axle Side
- x1** 42020 Pin Retainer, Long

**Drive Shaft Lengths**

	Front (mm)	Rear (mm)
Female 1	33	33
Female 2	33	42
Male	46	60

**NOTE:** Build a front and rear drive shaft

### GATE 09 CHASSIS BUILD:

- x1** 42022 Screw Pin
- x1** 42022 Screw Pin

**NOTE:** Install the front drive shaft

### GATE 10 CHASSIS BUILD:

- x2** 25203 3x12mm FHCS
- x1** 42304 Shock Mount (Right, Front)
- x1** 4689 3x16mm Set Screw
- x1** 42314 Drive Shaft, Male (46mm, 60mm)
- x2** 25211 3x10mm BHCS
- x1** 42305 Floor Board
- x1** 31532 3x8mm BHCS
- x2** 25211 3x10mm BHCS
- x1** 31532 3x8mm BHCS
- x1** 42257 Chassis Rail Left
- x2** 25211 3x10mm BHCS
- x1** 31532 3x8mm BHCS

## GATE 11

### CHASSIS BUILD:

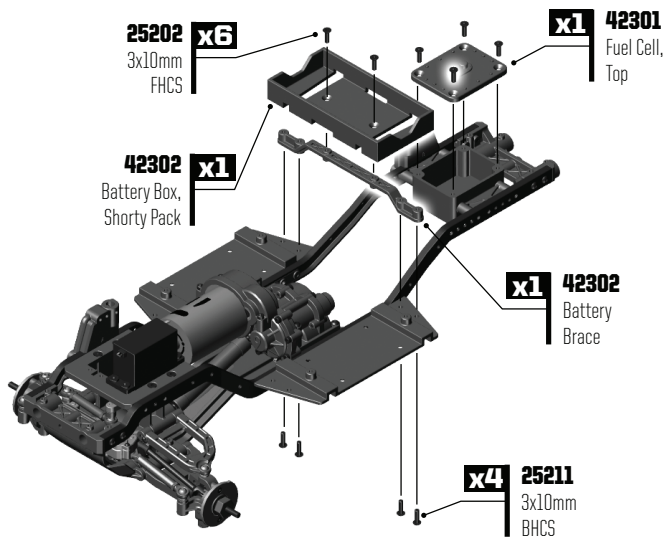

**NOTE:** Install Left and Right side Rock Sliders

**71050** x2  
Hook and Loop Straps

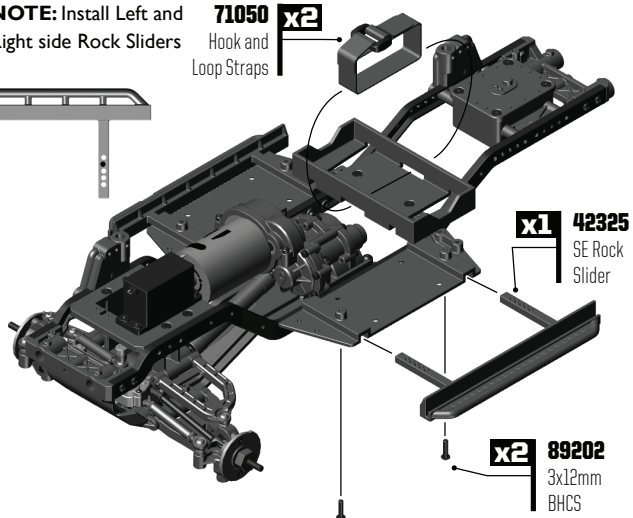

## GATE 12

### CHASSIS BUILD:



**NOTE:** Install Left and Right side Fenders

**42303** x1  
Front Fender (Left, Right)

**x1** Battery

**25188** x1  
3x20mm BHCS

**x2** **31532**  
3x8mm BHCS

**42007** x1  
Receiver Grommet Plug

**x1** **42007**  
Receiver Grommet

**42305** x1  
ESC Tray

**x1** **42305**  
Receiver Box Bottom

**25201** x4  
3x8mm FHCS

**x4** **25202**  
3x10mm FHCS

## GATE 13

### CHASSIS BUILD:

**ESC** x1

**6727** x1  
Servo Tape

**x1** Receiver

**x1** **6727**  
Servo Tape

**6338** x1  
Antenna Tube and Cap

**x1** **25225**  
3x3mm Set Screw

**42305** x1  
Receiver Box Lid

**x4** **25202**  
3x10mm FHCS

**x1** **42007**  
Receiver Box Grommet

**GATE 14** CHASSIS BUILD:

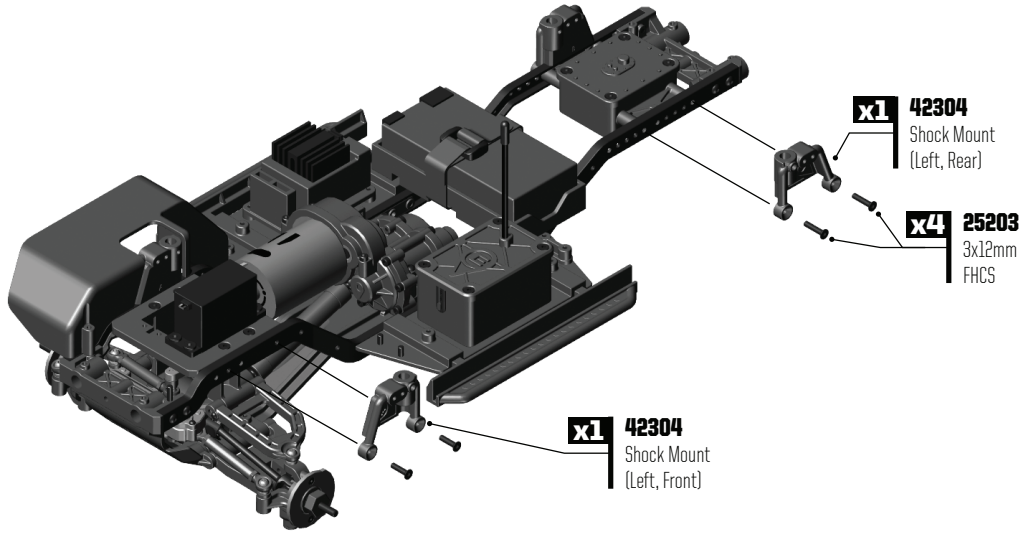

**GATE 01** REAR AXLE BUILD:



**42336**  
FT Ring/Pinion Option

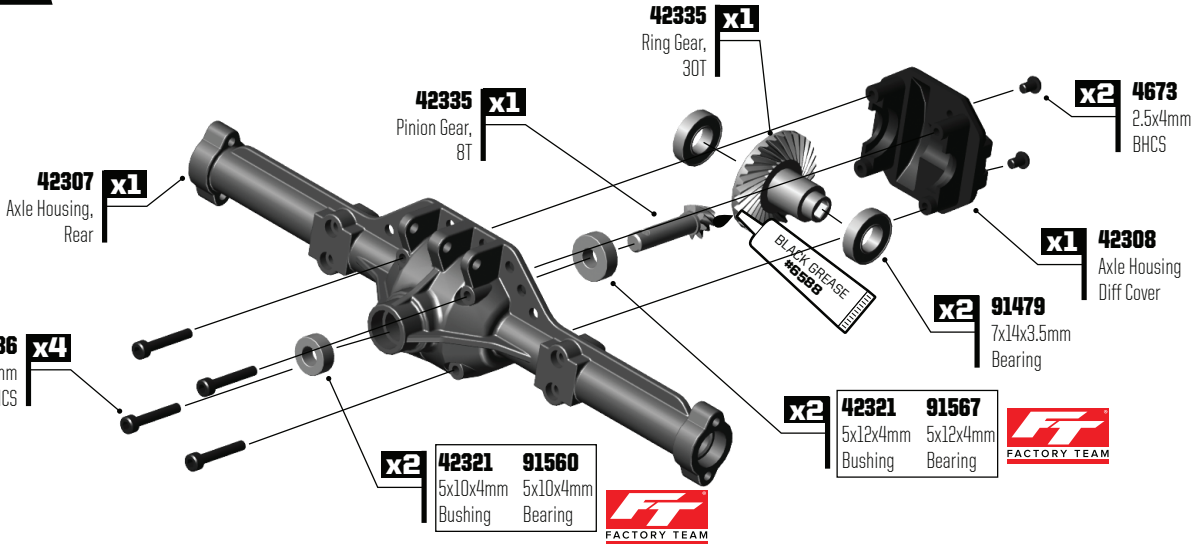

**GATE 02** REAR AXLE BUILD:

**NOTE:** Install left and right side axle mounts and wheel hexes

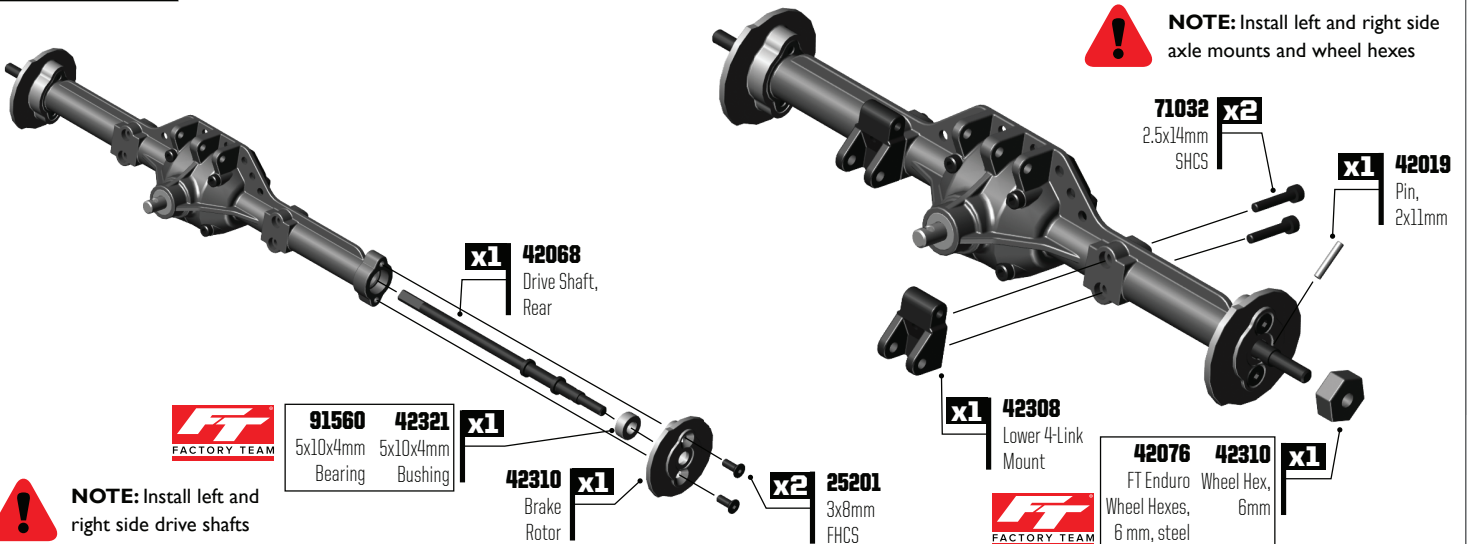

**NOTE:** Install left and right side drive shafts

**GATE 01 LINKS BUILD:**

**NOTE:** Build and install two rear upper links

**NOTE:** Check the rod end angles before installation

**NOTE:** Install the rear drive shaft

42041 x2 Pivot Ball, 6mm

42344 x1 Link, 146mm

25188 x1 3x20mm, BHCS

41078 x1 3x28mm BHCS

25215 x2 M3 Locknut, Black

146.00mm

**GATE 02 LINKS BUILD:**

**NOTE:** Check the rod end angles before installation

**NOTE:** Build and install two rear lower links

42344 x1 Link, 152mm

42041 x2 Pivot Ball, 6mm

4689 x1 3x18mm Set Screw

152.00mm

**GATE 01 REAR DRIVESHAFT BUILD:**

**NOTE:** Make sure the screw pins are aligned with each female CVA during assembly

**NOTE:** Make sure the phasing of the drive shafts is correct when installing them to the axles and gearbox.

FRONT

REAR

33 46 33 42 60 33

42022 x4 Screw Pin

THREAD LOCK #1596

Correct Phasing

Incorrect Phasing

**GATE 01 SHOCK BUILD:**

**Pro Tip:**  
Use #1105 Green Slime on O-Rings

+0	
+3	Rear
+6	Front

**NOTE:** Build 4 complete shocks

**GATE 02 SHOCK BUILD:**

**Shock Bleeding Steps:**

1. Pull shock shaft down.
2. Fill shock body 3/4 full with silicone fluid.
3. Slowly move the shock shaft up and down to remove air from under piston.
4. Wait for bubbles to come to surface.
5. Fill shock body to top with silicone fluid.
6. Place a drop of oil in the cap and on cap threads.
7. Install cap and tighten completely.
8. Slowly compress shaft all the way to the top. If there is pressure at the top of the stroke, there is too much oil or air. You must bleed it out.
9. Slowly pull shaft out.
10. Unscrew the cap 3/4 turn and tilt the shock at a slight angle.
11. Slowly compress the shaft to push out excess oil and air. You should see bubbles coming out from under the cap.
12. With the shaft compressed, tighten the cap and re-check for pressure at the top of the stroke. If there is still pressure, repeat steps 9 thru 11.

Front	1,000
Rear	350

**NOTE:** Build 4 complete shocks

**GATE 03 SHOCK BUILD:**

#42313 Soft	Green	Rear Spring
	White	
	Gray	
	Blue	
#42347 Hard	Yellow	Front Spring
	Red	
	Orange	
	Purple	

**NOTE:** Build 4 complete shocks

**GATE 04 SHOCK BUILD:**

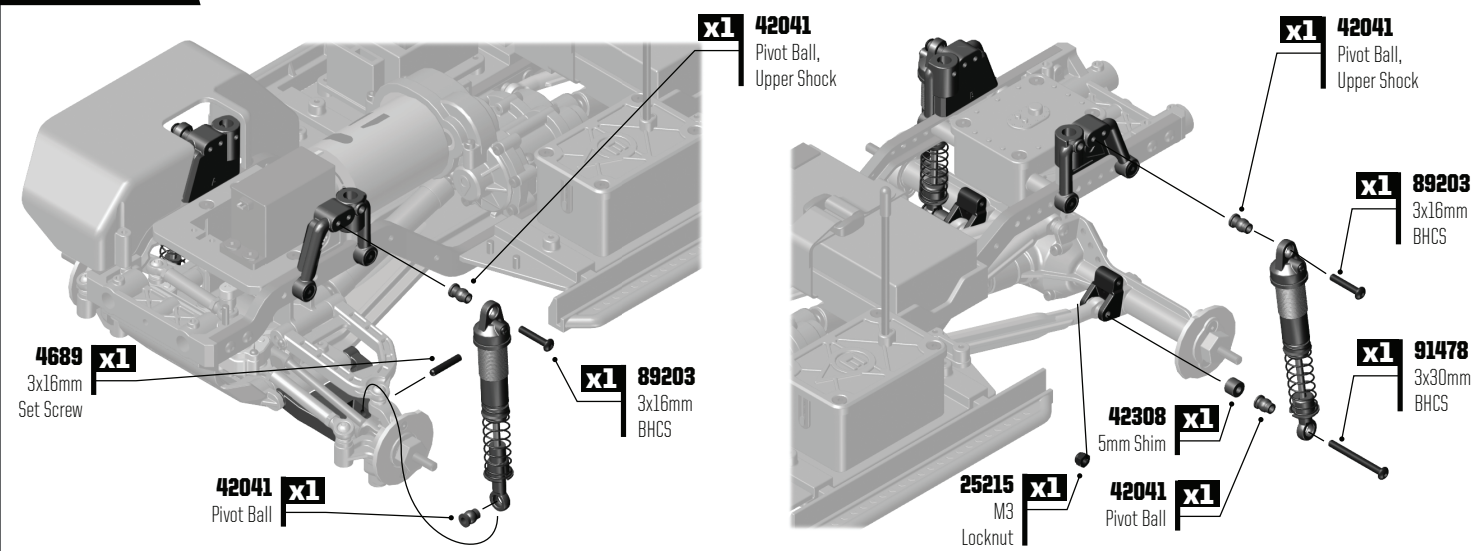

**GATE 01 BUMPER BUILD:**

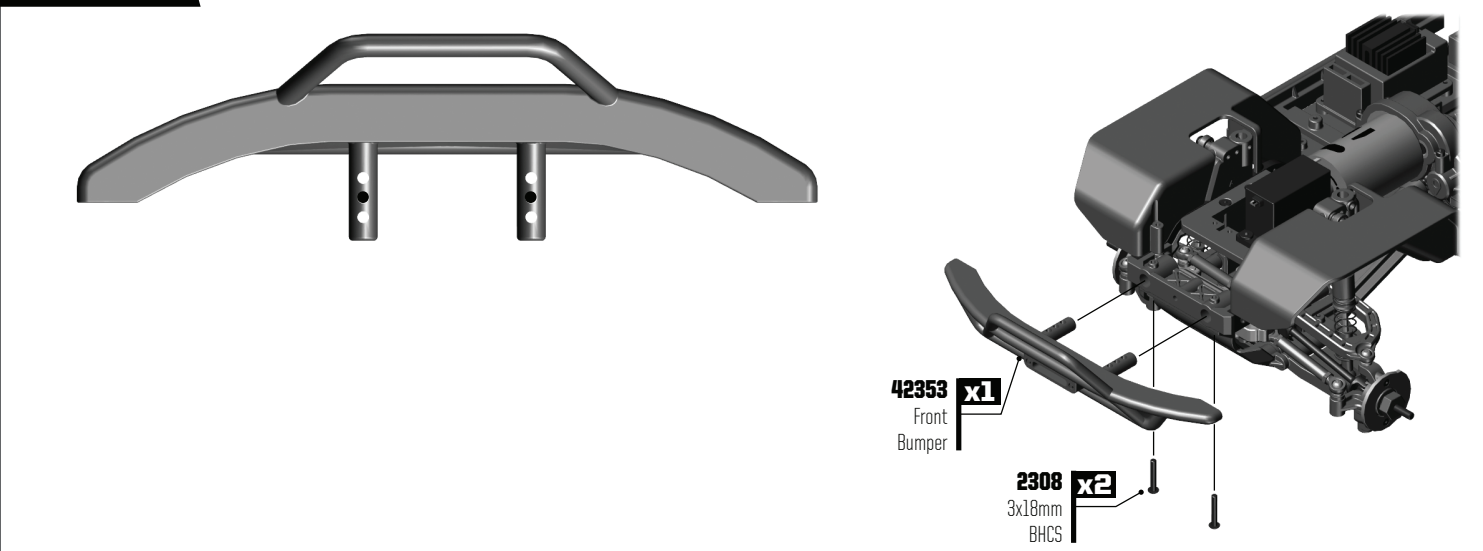

**GATE 02 BUMPER BUILD**

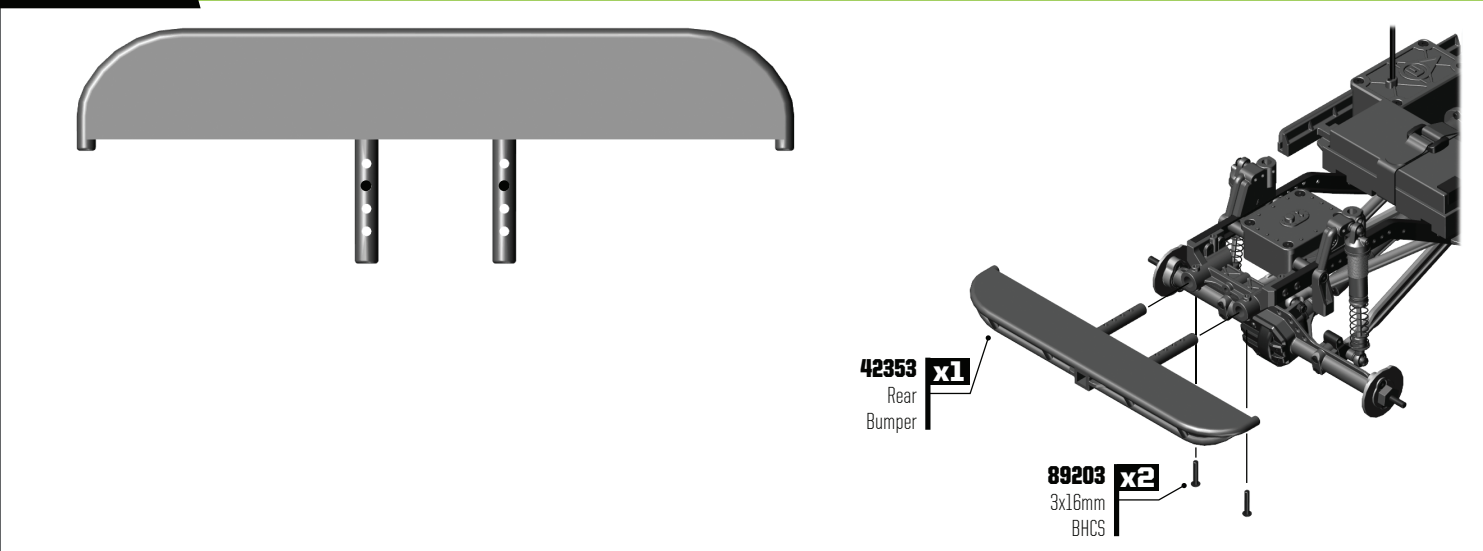

## GATE 01 WHEEL/TIRE BUILD

**x1 42328** Inner Wheel, Black

**x1 42349** Pinseeker Tire

**x1 42329** Tire, Insert

**x1 42328** Ring, Black

**x1 42328** Outer Wheel, Black

**\*Optional Hex Adapters**  
 42103 Aluminum  
 42104 Brass

**x1 42328** Hex Adapter, Black

**NOTE:** Install #41088 screws in a crossing pattern

**x6 42332** 2.6x10mm SHCS, Silver

**NOTE:** Build 4 wheels/tires

## GATE 02 WHEEL/TIRE BUILD

**NOTE:** Install 4 wheels/tires

**Front Post** **Rear Post**

**x2 42009** Body Mount, Short Pin

**x2 42328** Nut Cap, Black

**x2 25391** FT M4 Locknut, Blue

**x2 42022** Screw Pin

**NOTE:** Install 4 body mounts

## GATE 01 BODY BUILD:

Bodies	
42351	RTR - Painted
42352	Clear

**x1 42352** Front Grill

**x1 42352** Utron Body

**x2 42352** Utron Rear Brake Light

**x2 42352** Utron Rear Brake Light Bracket

**x2 31531** 3x6mm BHCS

**x1 42352** Front Grill Bracket

**6332 x4** Body Clips

**GATE 01** STEALTH XF: BUILD CONFIGURATION:



**OVERDRIVE:**

Overdrive is a scenario where the front and rear wheels do not rotate at the same speed. The Stealth XF gearbox is designed to allow the front wheels to spin faster than the rear wheels. Overdrive is advantageous when climbing up rock faces because the front tires will want to pull the vehicle up the rock. On deserts, the rear tires rotating slower than the front tires will help keep the chassis more stable and keep the rear tires planted on the ground.

**Stealth XF:**

The Stealth XF gearbox comes factory assembled with no overdrive (1:1).

With additional parts, the Stealth XF gearbox allows the driver to change the front to rear drive ratios with 3 separate ratio adjustments to the rear drive shaft.

**Items Needed for OVERDRIVE:**

#42025, #42027, #91563, #42026 -OR- #42031, #42028 -OR- #42032

**Please Note:**

The 20T top shaft, 28T idler gear, and 52T drive gear will always be meshed together in all 3 gearbox configurations.

**GATE 02** STEALTH X: BUILD CONFIGURATION: MOTOR MOUNT FACING REAR (STOCK)

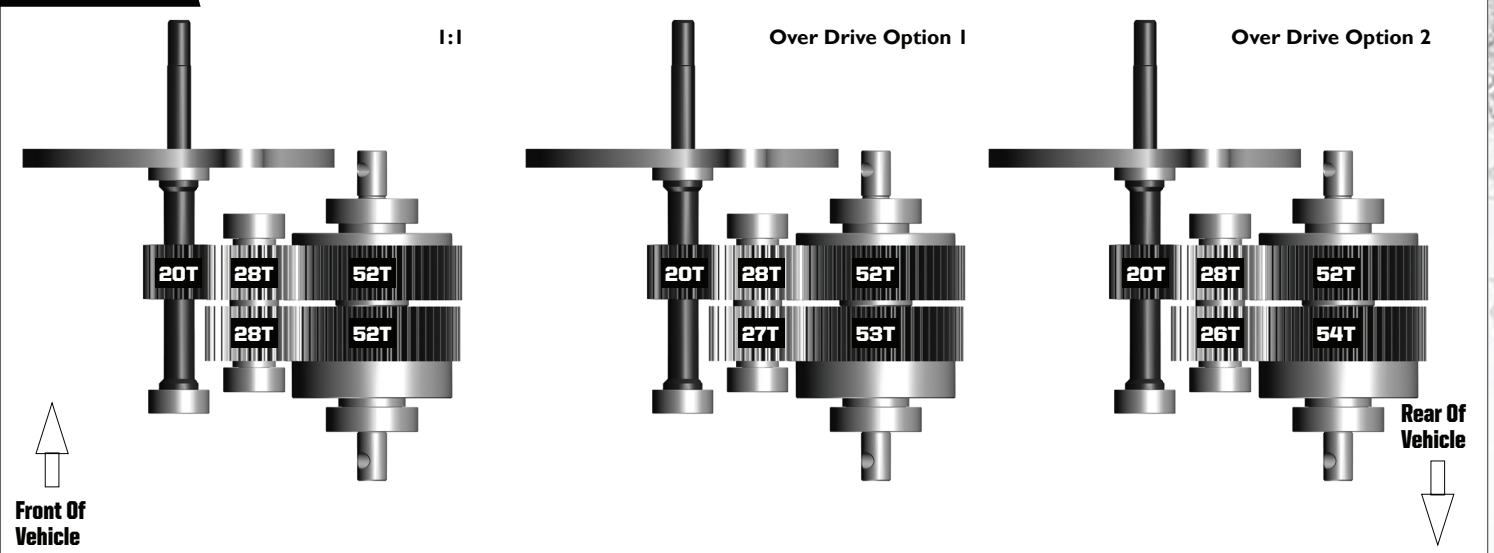

**GATE 03** LINKS: WHEELBASE CHART - PARTS NEEDED

**WHEELBASE CHART**

WB	FRONT UPPER	FRONT LOWER	REAR UPPER	REAR LOWER
11.8"	93mm #42184	100mm #42185 #42186	93mm #42184	100mm #42185 #42186
12.0"	93mm #42184	100mm #42185 #42186	100mm #42185	108mm #42187 #42188
12.3"	93mm #42184	100mm #42185 #42186	108mm #42187	114mm #42189 #42190
12.8"	93mm #42184	100mm #42185 #42186	121mm #42191	127mm #42192 #42193



**Items Needed for Links:**

#42040 - Rod Ends

**Panhard Links [CMS]:**

Panhard - #42183

Steering Input - #42182

Steering Link - #42180

**Servo on Axle Links [SOA]:**

[SOA]:

Links - #42323

Steering Link - #42180

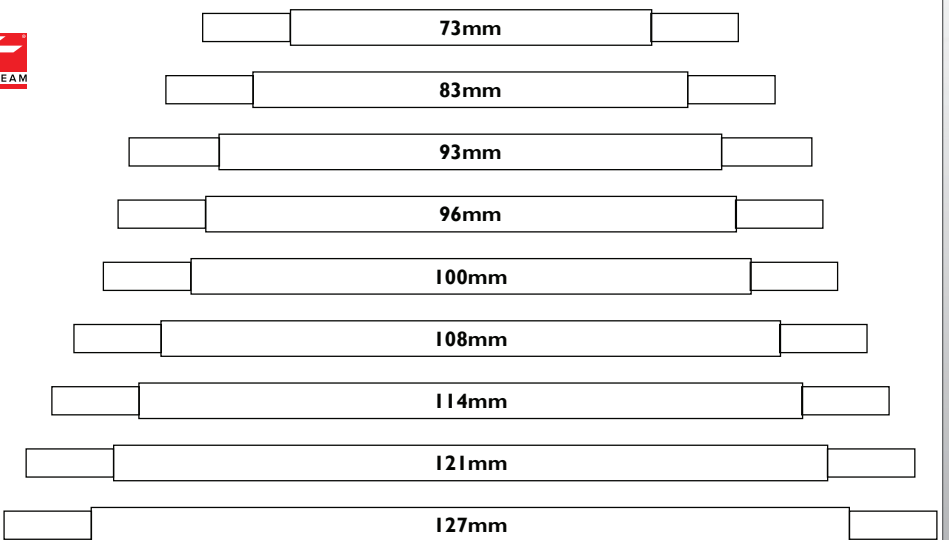



## TRAIL TIPS AND CHECKLIST

### PREPARING TO HIT THE TRAIL:

When preparing to hit the trail, it's a good idea to have a checklist to make sure you have everything and don't end up having to head back early. We've compiled a checklist of the things we think you'll need on the trail. We've also left some space for you to add your specific items to the list. Keep in mind these are suggestions and every person will require different items. Weather and altitude will also dictate how much food and water a person will require. Do a little research first before heading out for a full day on the trail.

- Truck with Charged Battery
- 1-2 spare Charged Batteries for your rig
- Radio with Charged Batteries
- Spare radio batteries
- Check all nuts and screws and tighten them. Including Wheel nuts!
- Spare parts (Nuts, Screws, Body Clips, and anything that may wear or break)
- Backpack
- Water (2 liters per person minimum)
- Snacks (protein bars, trailmix, etc.)
- Sturdy shoes (Hiking boots preferably or something with grip and ankle support)
- Element Hat or Beanie
- Element Hoodie or Jacket
- Sunscreen
- Bug Spray
- Lip Balm
- Nut Drivers (Factory Team Nut Drivers #1507, 1508)
- Allen wrenches (Factory Team Hex Driver set #1655)
- Cell phone and charger
- Headlight or flashlight with spare batteries
- Compact action camera
- Camera
- Tripod
- \_\_\_\_\_
- \_\_\_\_\_
- \_\_\_\_\_
- \_\_\_\_\_
- \_\_\_\_\_
- \_\_\_\_\_

### TREAD LIGHTLY:

Remember, when driving your rig out on the trails, it's important to tread lightly. We all know that the best place to enjoy our hobby is out in nature, and that means we need to preserve it for future hobbyist so we all have a place to enjoy. Here are a few tips to remember when out on the trail.

- **Pack In/Pack Out:**

Don't leave anything behind. Whether it's trash, parts, or food. If you brought it, take it with you.

- **National and Public Parks:**

If visiting a national park, leave the RC cars at home. It is illegal to drive any radio control vehicle within national park boundaries. Public parks are slightly different, some may allow radio control cars and others may not. Check with your local officials before driving in a public park.

- **Be Considerate:**

Where ever you drive your radio control car, always be considerate of others. Hikers, bicyclists, and animals should always be given the right of way.

- **Keep It Quiet:**

If you're sharing an area with other people, try to keep the noise to a minimum. If you come across animals or anglers, please be considerate and give them space.

- **Give A Hoot, Don't Pollute:**

When enjoying the outdoors take your trash with you. Not only is it bad for the environment, it's unsightly. If you see trash, pick it up, even if it isn't yours. If we all do our part we can work together to keep our planet beautiful for future generations.

- **Only You Can Prevent Wild Fires:**

Some of us like to mix camping with RC cars. This is great! Just remember to follow all safety precautions and put out any camp fires before calling it a night. Also, be sure to unplug and **store all LiPo batteries in LiPo sacks and a fire resistant storage device.**

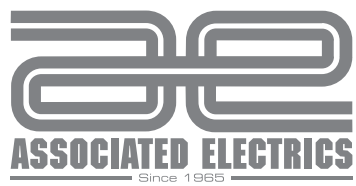
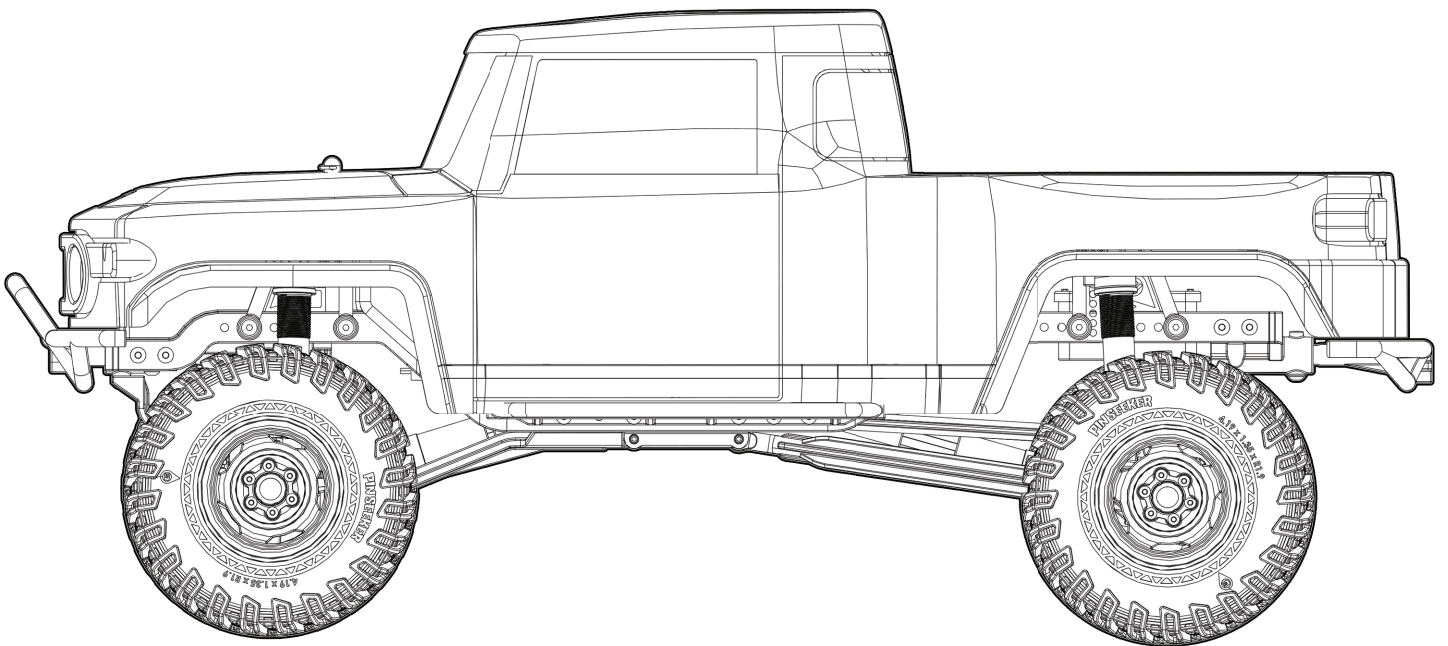

**ASSOCIATED ELECTRICS, INC.**  
**21062 BAKE PARKWAY, LAKE FOREST, CA 92630 USA**

CALL: (949) 544-7500 - FAX: (949) 544-7501  
CHECK OUT THE FOLLOWING WEB SITES FOR ALL OF OUR KITS,  
CURRENT PRODUCTS, NEW RELEASES, SETUP HELP, TIPS, AND RACING INFO!  
**[WWW.ASSOCIATEDELECTRICS.COM](http://WWW.ASSOCIATEDELECTRICS.COM)**



ElementRC



@Element\_RC