

XRAY
1/10 LUXURY ELECTRIC STADIUM TRUCK

INSTRUCTION MANUAL

MADE IN
EUROPE



INTRODUCTION

The XRAY XT2 is a modern, high-competition premium luxury racing 1/10 electric 2WD off-road stadium truck that is the epitome of high-performance and fine distinctive design. Your XT2 offers highest performance, responsive handling, and traditionally exceptional XRAY quality, engineering, and design. The superb craftsmanship and attention to detail are clearly evident everywhere on the XRAY XT2.

XT2 was designed around a no compromise platform; the attention to detail creates a low maintenance, extra long life electric stadium truck. The ultra-low center of gravity (CG) and optimized weight balance makes set-up, driving, and maintenance easy and quick.

CUSTOMER SUPPORT

We have made every effort to make these instructions as easy to understand as possible. However, if you have any difficulties, problems, or questions, please do not hesitate to contact the XRAY support team at info@teamxray.com. Also, please visit our Web site at www.teamxray.com to find the latest updates, set-up information, option parts, and many other goodies. We pride ourselves on taking excellent care of our customers.

You can join thousands of XRAY fans and enthusiasts in our online community at: www.teamxray.com

The XRAY XT2 was created by blending highest-quality materials and excellent design. On high-speed flat tracks or bumpy tracks, whether driving for fun or racing to win, the XT2 delivers outstanding performance, speed, and precision handling.

We have made every effort to make these instructions as easy to understand as possible. However, if you have any difficulties, problems, or questions, please do not hesitate to contact the XRAY support team at info@teamxray.com. Also, please visit our web site at www.teamxray.com to find the latest updates, set-up information, option parts, and many other goodies. We pride ourselves on taking excellent care of our customers.

XRAY Europe

K Výstavisku 6992
91101 Trenčín
Slovakia, EUROPE
Phone: +421-32-7401100
Fax: +421-32-7401109
Email: info@teamxray.com

XRAY USA

RC America, 2030 Century Center Blvd #15
Irving, TX 75062
USA
Phone: (800) 519-7221 * (214) 744-2400
Fax: (214) 744-2401
Email: xray@rcamerica.com

Failure to follow these instructions will be considered as abuse and/or neglect.

SAFETY PRECAUTIONS

Contains:

LEAD (CAS 7439-92-1) ANTIMONY (CAS 7440-36-0)

WARNING: This product contains a chemical known to the state of California to cause cancer and birth defects or other reproductive harm.

CAUTION: CANCER HAZARD

Contains lead, a listed carcinogen. Lead is harmful if ingested. Wash thoroughly after using. DO NOT use product while eating, drinking or using tobacco products. May cause chronic effects to gastrointestinal tract, CNS, kidneys, and blood. MAY CAUSE BIRTH DEFECTS.

When building, using and/or operating this model always wear protective glasses and gloves.

Take appropriate safety precautions prior to operating this model. You are responsible for this model's assembly and safe operation! Please read the instruction manual before building and operating this model and follow all safety precautions. Always keep the instruction manual at hand for quick reference, even after completing the assembly. Use only genuine and original authentic XRAY parts for maximum performance. Using any third party parts on this model will void guaranty immediately.

Improper operation may cause personal and/or property damage. XRAY and its distributors have no control over damage resulting from shipping, improper construction, or improper usage. XRAY assumes and accepts no responsibility for personal and/or property damages resulting from the use of improper building materials, equipment and operations. By purchasing any item produced by XRAY, the buyer expressly warrants that he/she is in compliance with all applicable federal, state and local laws and regulation regarding the purchase, ownership and use of the item. The buyer expressly agrees to indemnify and hold harmless XRAY for all claims resulting directly or indirectly from the purchase, ownership or use of the product. By the act of assembling or operating this product, the user accepts all resulting liability. If the buyer is not prepared to accept this liability, then he/she should return this kit in new, unassembled, and unused condition to the place of purchase.

IMPORTANT NOTES - GENERAL

- This product is not suitable for children under 16 years of age without the direct supervision of a responsible and knowledgeable adult.
- Carefully read all manufacturers warnings and cautions for any parts used in the construction and use of your model.
- Assemble this kit only in places away from the reach of very small children.
- First-time builders and users should seek advice from people who have building experience in order to assemble the model correctly and to allow the model to reach its performance potential.
- Exercise care when using tools and sharp instruments.
- Take care when building, as some parts may have sharp edges.
- Keep small parts out of reach of small children. Children must not be allowed to put any parts in their mouth, or pull vinyl bag over their head.
- Read and follow instructions supplied with paints and/or cement, if used (not included in kit).
- Immediately after using your model, do NOT touch equipment on the model such as the motor and speed controller, because they generate high temperatures. You may seriously burn yourself seriously touching them.
- Follow the operating instructions for the radio equipment at all times.
- Do not put fingers or any objects inside rotating and moving parts, as this may cause damage or serious injury as your finger, hair, clothes, etc. may get caught.
- Be sure that your operating frequency is clear before turning on or running your model, and never share the same frequency with somebody else at the same time. Ensure that others are aware of the operating frequency you are using and when you are using it.
- Use a transmitter designed for ground use with RC cars. Make sure that no one else is using the same frequency as yours in your operating area. Using the same frequency at the same time, whether it is driving, flying or sailing, can cause loss of control of the RC model, resulting in a serious accident.
- Always turn on your transmitter before you turn on the receiver in the car. Always turn off the receiver before turning your transmitter off.
- Keep the wheels of the model off the ground when checking the operation of the radio equipment.
- Disconnect the battery pack before storing your model.
- When learning to operate your model, go to an area that has no obstacles that can damage your model if your model suffers a collision.
- Remove any sand, mud, dirt, grass or water before putting your model away.
- If the model behaves strangely, immediately stop the model, check and clear the problem.
- To prevent any serious personal injury and/or damage to property, be responsible when operating all remote controlled models.
- The model car is not intended for use on public places and roads or areas where its operation can conflict with or disrupt pedestrian or vehicular traffic.
- Because the model car is controlled by radio, it is subject to radio interference from many sources that are beyond your control. Since radio interference can cause momentary loss of control, always allow a safety margin in all directions around the model in order to prevent collisions.
- Do not use your model:
 - Near real cars, animals, or people that are unaware that an RC car is being driven.
 - In places where children and people gather
 - In residential districts and parks
 - In limited indoor spaces
 - In wet conditions
 - In the street
 - In areas where loud noises can disturb others, such as hospitals and residential areas.
 - At night or anytime your line of sight to the model may be obstructed or impaired in any way.

To prevent any serious personal injury and/or damage to property, please be responsible when operating all remote controlled models.

IMPORTANT NOTES - ELECTRICAL

- Insulate any exposed electrical wiring (using heat shrink tubing or electrical tape) to prevent dangerous short circuits. Take maximum care in wiring, connecting and insulating cables. Make sure cables are always connected securely. Check connectors for if they become loose. And if so, reconnect them securely. Never use R/C models with damaged wires. A damaged wire is extremely dangerous, and can cause short-circuits resulting in fire. Please have wires repaired at your local hobby shop.
- Low battery power will result in loss of control. Loss of control can occur due to a weak battery in either the transmitter or the receiver. Weak running battery may also result in an out of control car if your car's receiver power is supplied by the running battery. Stop operation immediately if the car starts to slow down.
- When not using RC model, always disconnect and remove battery.
- Do not disassemble battery or cut battery cables. If the running battery short-circuits, approximately 300W of electricity can be discharged, leading to fire or burns. Never disassemble battery or cut battery cables.
- Use a recommended charger for the receiver and transmitter batteries and follow the instructions correctly. Over-charging, incorrect charging, or using inferior chargers can cause the batteries to become dangerously hot.

- Recharge battery when necessary. Continual recharging may damage battery and, in the worst case, could build up heat leading to fire. If battery becomes extremely hot during recharging, please ask your local hobby shop for check and/or repair and/or replacement.
- Regularly check the charger for potential hazards such as damage to the cable, plug, casing or other defects. Ensure that any damage is rectified before using the charger again. Modifying the charger may cause short-circuit or overcharging leading to a serious accident. Therefore do not modify the charger.
- Always unplug charger when recharging is finished.
- Do not recharge battery while battery is still warm. After use, battery retains heat. Wait until it cools down before charging.
- Do not allow any metal part to short circuit the receiver batteries or other electrical/electronic device on the model.
- Immediately stop running if your RC model gets wet as may cause short circuit.
- Please dispose of batteries responsibly. Never put batteries into fire.

R/C & BUILDING TIPS

- Make sure all fasteners are properly tightened. Check them periodically.
- Make sure that chassis screws do not protrude from the chassis.
- For the best performance, it is very important that great care is taken to ensure the free movement of all parts.
- Clean all ball-bearings so they move very easily and freely.
- Tap or pre-thread the plastic parts when threading screws.
- Self-tapping screws cut threads into the parts when being tightened. Do not use excessive force when tightening the self-tapping screws because you may strip out the thread in the plastic. We recommended you stop tightening a screw when you feel some resistance.
- Ask your local hobby shop for any advice.

Please support your local hobby shop. We at XRAY Model Racing Cars support all local hobby dealers. Therefore we ask you, if at all possible, to purchase XRAY products at your hobby dealer and give them your support like we do. If you have difficulty finding XRAY products, please check out www.teamxray.com to get advice, or contact us via email at info@teamxray.com, or contact the XRAY distributor in your country.

WARRANTY

XRAY guarantees this model kit to be free from defects in both material and workmanship within 30 days of purchase. The total monetary value under warranty will in no case exceed the cost of the original kit purchased. This warranty does not cover any components damaged by use or modification or as a result of wear. Part or parts missing from this kit must be reported within 30 days of purchase. No part or parts will be sent under warranty without proof of purchase. Should you find a defective or missing part, contact the local distributor. Service and customer support will be provided through local hobby store where you have purchased the kit, therefore make sure to purchase any XRAY products at your local hobby store. This model racing car is considered to be a high-performance racing vehicle. As such this vehicle will be used in an extreme range of conditions and situations, all which may cause premature wear or failure of any component. XRAY has no control over usage of vehicles once they leave the dealer, therefore XRAY can only offer warranty against all manufacturer's defects in materials, workmanship, and assembly at point of sale and before use. No warranties are expressed or implied that cover damage caused by what is considered normal use, or cover or imply how long any model cars' components or electronic components will last before requiring replacement.

Due to the high performance level of this model car you will need to periodically maintain and replace consumable components. Any and all warranty coverage will not cover replacement of any part or component damaged by neglect, abuse, or improper or unreasonable use. This includes but is not limited to

damage from crashing, chemical and/or water damage, excessive moisture, improper or no maintenance, or user modifications which compromise the integrity of components. Warranty will not cover components that are considered consumable on RC vehicles. XRAY does not pay nor refund shipping on any component sent to XRAY or its distributors for warranty. XRAY reserves the right to make the final determination of the warranty status of any component or part.

Limitations of Liability

XRAY makes no other warranties expressed or implied. XRAY shall not be liable for any loss, injury or damages, whether direct, indirect, special, incidental, or consequential, arising from the use, misuse, or abuse of this product and/or any product or accessory required to operate this product. In no case shall XRAY's liability exceed the monetary value of this product.

Take adequate safety precautions prior to operating this model. You are responsible for this model's assembly and safe operation.

Disregard of the any of the above cautions may lead to accidents, personal injury, or property damage. XRAY MODEL RACING CARS assumes no responsibility for any injury, damage, or misuse of this product during assembly or operation, nor any addictions that may arise from the use of this product.

All rights reserved.

QUALITY CERTIFICATE

XRAY MODEL RACING CARS uses only the highest quality materials, the best compounds for molded parts and the most sophisticated manufacturing processes of TQM (Total Quality Management). We guarantee that all parts of a newly-purchased kit are manufactured with the highest regard to quality. However, due to the many factors inherent in model racecar competition, we cannot guarantee

any parts once you start racing the car. Products which have been worn out, abused, neglected or improperly operated will not be covered under warranty. We wish you enjoyment of this high-quality and high-performance RC car and wish you best success on the track!

In line with our policy of continuous product development, the exact specifications of the kit may vary. In the unlikely event of any problems with your new kit, you should contact the model shop where you purchased it, quoting the part number.

We do reserve all rights to change any specification without prior notice. All rights reserved.

SYMBOLS USED

Part bags used 	Assemble in the specified order 	Assemble left and right sides the same way 	Pay attention here 	Assemble as many times as specified (here twice) 	Apply threadlock 	Apply CA glue 	Apply oil
Scale 	Apply grease 	Optional parts 	Ensure smooth non-binding movement 	Tighten screw gently 	Completed assembly 	Detail 	Apply cleaner

TOOLS REQUIRED

Scissors (HUDY #188990) 	Special Tool for turnbuckles, nuts (HUDY #181090) 	Turnbuckle Wrench 3mm (HUDY #181030) 	Side Cutters (HUDY #189010) 	Hobby Knife 	Combination Pliers (HUDY #189020) 	Reamer (HUDY #107600) or (HUDY #107601)
Tweezer 	HUDY TOOLS: Allen 1.5mm Allen 2.0mm Socket 5.5mm Socket 7.0mm Arm Reamer 3.0mm					

ITEMS INCLUDED

HUDY Premium Silicone Oils Oil 500cSt (#106350) 	HUDY Premium Silicone Oils Oil 600cSt (#106360) 	HUDY Premium Silicone Oils Oil 5000cSt (#106450) 	Graphite Grease (HUDY #106210)
--	--	---	---------------------------------------

EQUIPMENT REQUIRED

Transmitter 	Receiver 	Steering Servo 	Electric Motor & Pinion Gear with Setscrew 	Bearing Oil (HUDY #106230) 	CA glue
Speed Controller 	LiPo Battery 	Lexan™ Paint 	Battery Charger 	Double-sided Tape 	Tires & Wheels

NOT INCLUDED



Follow Set-Up Book

To ensure that you always have access to the most up-to-date version of the Set-up Book you can download the HUDY Set-up Book from their web site at [www.hudy.net] By offering this online version instead of including a hardcopy printed version in kits, you will always be assured of having the most current updated version.

SAMPLE OF OPTIONAL PARTS

#32XXXX	OPTION 1
#32XXXX	OPTION 2
#32XXXX	INCLUDED
#32XXXX	OPTION 3

XRAY offers wide range of optional tuning parts which are listed in a table like this. Please refer to the exploded view of each main section to verify which part is included in the kit while all other parts are available only as an optional part and must be purchased separately.

COLOR INDICATIONS

At the beginning of each section is an exploded view of the parts to be assembled. There is also a list of all the parts and part numbers that are related to the assembly of that section.

The part descriptions are color-coded to make it easier for you to identify the source of a part. Here are what the different colors mean:

365884

STYLE A - indicates parts that are included in the bag marked for the section.

321100

STYLE B - indicates parts that are included in the box.

324900

STYLE C - indicates parts that are already assembled from previous steps.

XB2 TECH TIPS

TIP DRIVE SHAFT PIN SERVICING

To enjoy the longest possible lifespan of the drive shafts and diff outrives, it is extremely important to properly service the drive shaft pins. Inspect the pins after every 3 hours of runtime. If the pins show any wear, replace them with new pins.



1 Do not use drive shafts when the pins are worn.

2 Press out the worn pins.

3 Press in new pins and regularly inspect for wear.



For quick & easy drive pin replacements use #106000 HUDY Drive Pin Replacement Tool.



To replace the worn pins use only premium HUDY drive pins #106051.

1. REAR DIFFERENTIAL



BEVEL & SATELLITE GEARS + PINS

OPTION	#304932 + #304980	COMPOSITE	INCLUDED
	#335030 + #335080	STEEL	OPTION

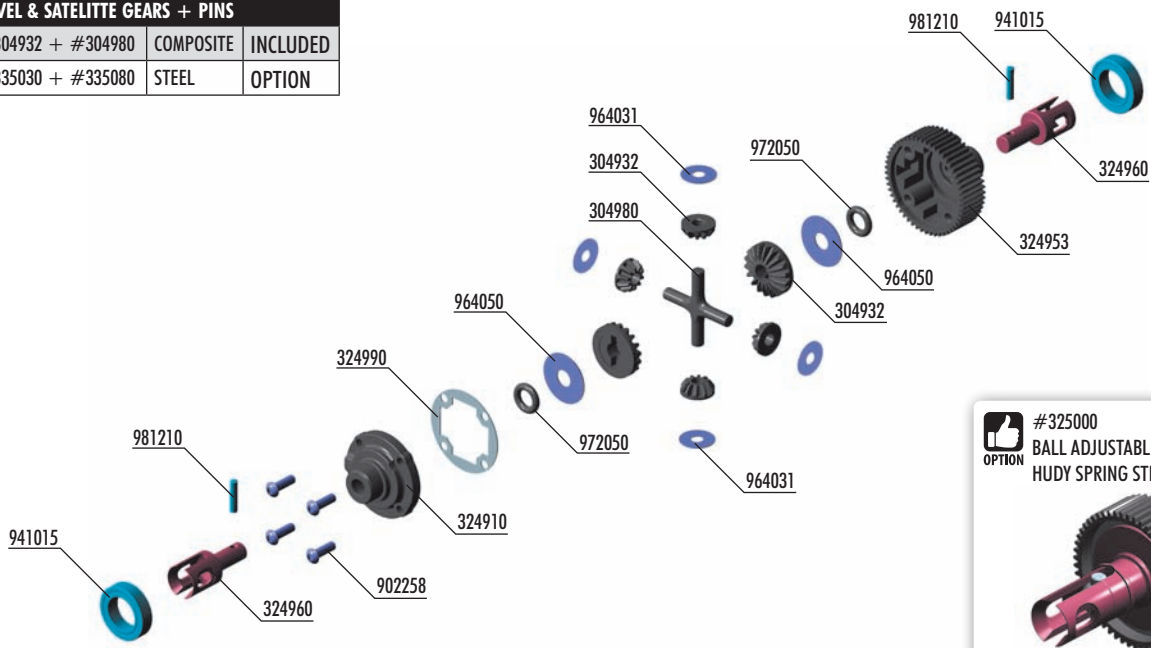

BAG



- 30 4932 GRAPHITE GEAR DIFF BEVEL & SATELLITE GEARS (2+4)
- 30 4980 COMPOSITE GEAR DIFF CROSS PIN
- 32 4990 DIFF GASKET (4)
- 32 4900 GEAR DIFFERENTIAL - SET
- 32 4910 COMPOSITE GEAR DIFFERENTIAL CASE
- 32 4953 COMPOSITE GEAR DIFFERENTIAL CASE WITH PULLEY 53T
- 32 4960 GEAR DIFF OUTDRIVE ADAPTER - HUDY SPRING STEEL™ (2)

- 32 5000 BALL ADJUSTABLE DIFFERENTIAL - SET - HUDY SPRING STEEL™ (OPTION)
- 90 2258 HEX SCREW SH M2.5x8 (10)
- 94 1015 HIGH-SPEED BALL-BEARING 10x15x4 RUBBER SEALED (2)
- 96 4031 WASHER S 3.5x10x0.2 (10)
- 96 4050 WASHER S 5x15x0.3 (10)
- 97 2050 SILICONE O-RING 5x2 (10)
- 98 1210 PIN 2x10 (10)

- 964050
S 5x15x0.3
- 972050
O 5x2
- 981210
P 2x10

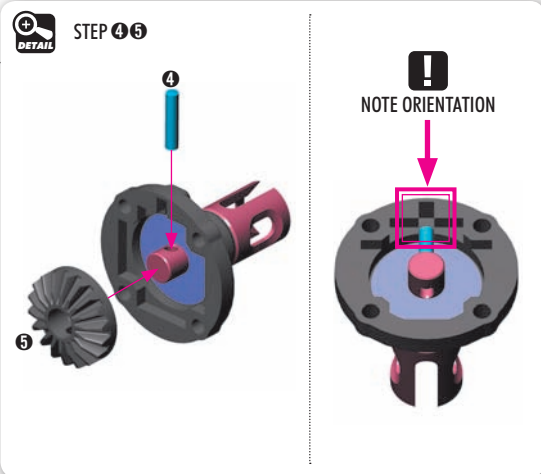
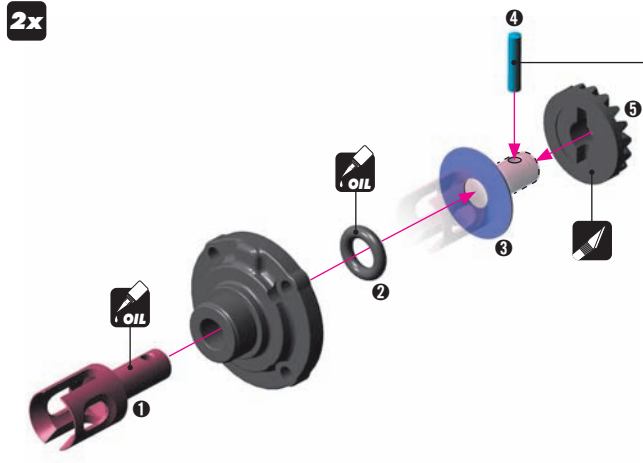

- 964050
S 5x15x0.3
- 972050
O 5x2
- 981210
P 2x10

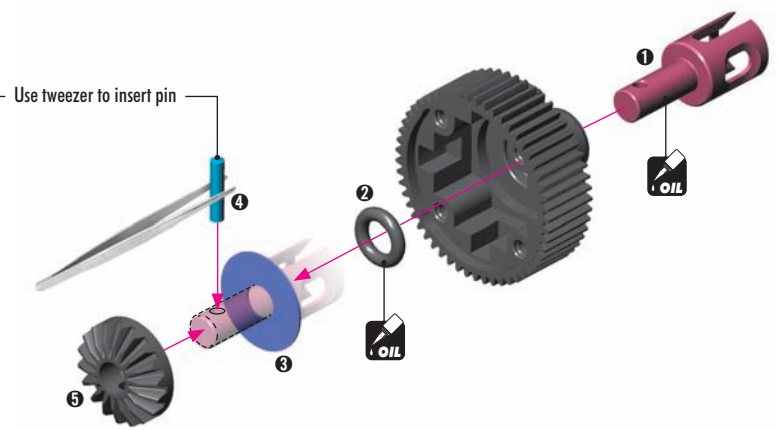
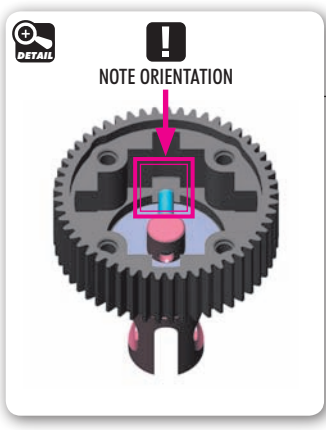

1. REAR DIFFERENTIAL



964031
5.3.5x10x0.2

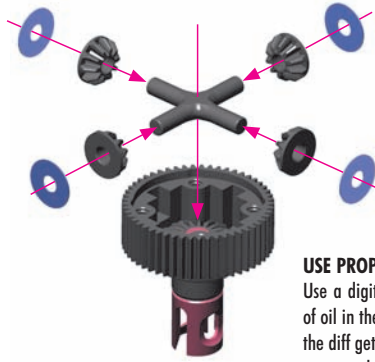

USE PROPER AMOUNT OF OIL IN THE DIFFS

Use a digital scale to measure the exact amount of oil in the diff. Remember that during operation the diff gets hotter and the heat may allow the oil to expand. If there is too much oil inside it may interfere with the diff operation and damage the internal gears.

Rear diff

Silicone oil 5 000cSt
Fill just above the diff pin.

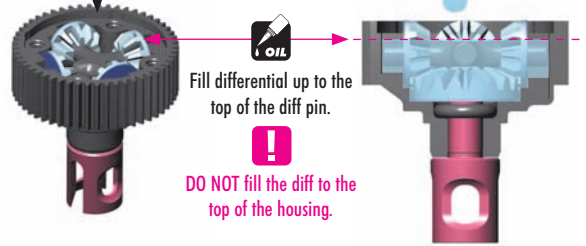

Fill differential up to the top of the diff pin.

DO NOT fill the diff to the top of the housing.

TO ENSURE YOU HAVE THE SAME AMOUNT OF OIL FROM REBUILD TO REBUILD, DO THE FOLLOWING:

1 Put the diff (without oil) on the scale and check the weight (approximately 11.23g)

2 Slowly pour oil into the diff and watch the weight. Add 0.95g of oil into the diff. The approximate weight of the diff including oil is 12.18g.

#107865
HUDY Ultimate Digital Pocket Scale 300g ± 0.01g

$11.23g + 0.95g = 12.18g$

TIP TIPS FOR REAR DIFFERENTIAL

LOW-MEDIUM TRACTION 3 000cSt (HUDY #106430)
MEDIUM-HIGH TRACTION 5 000cSt (HUDY #106450)

NOTE: Softer oil increases rear traction, harder oil increases on-power steering.



HUDY ULTIMATE SILICONE OILS

OPTION	Oil #	Viscosity	Availability
	#106410	1000 cSt - 50ml	OPTION
	#106420	2000 cSt - 50ml	OPTION
	#106430	3000 cSt - 50ml	OPTION
	#106450	5000 cSt - 50ml	INCLUDED
	#106460	6000 cSt - 50ml	OPTION
	#106470	7000 cSt - 50ml	OPTION

SET-UP BOOK

DIFFERENTIAL OIL



902258
SH M2.5x8



941015
BB 10x15x4



Tighten the screws equally but do NOT tighten them completely.

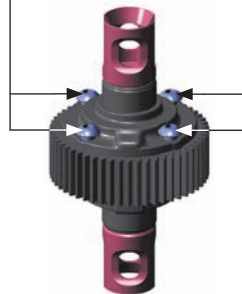

Finish tightening in this order.

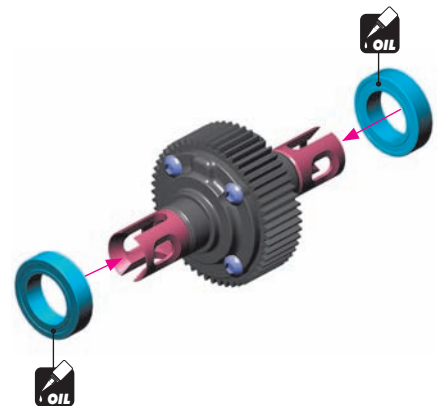
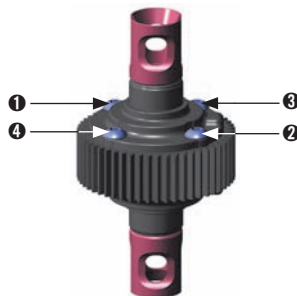

2. REAR TRANSMISSION

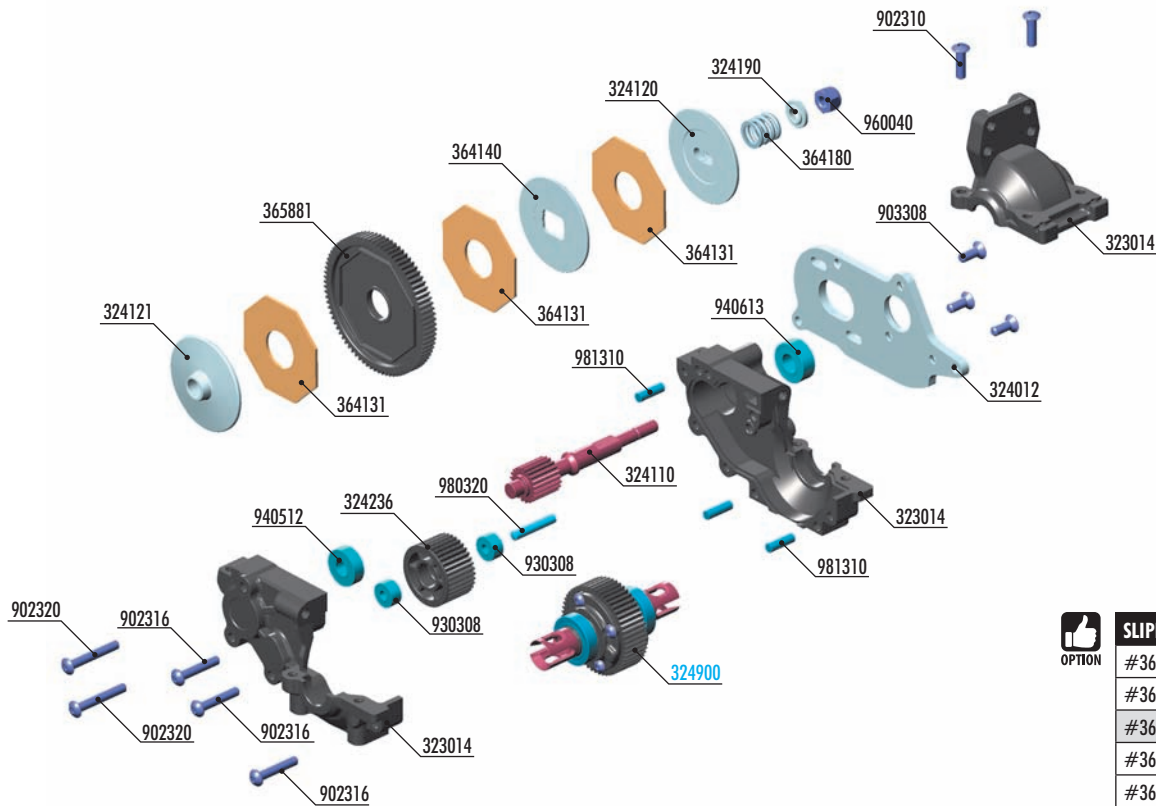

SLIPPER CLUTCH SPUR GEARS			
#365875	75T / 48	OPTION	
#365878	78T / 48	OPTION	
#365881	81T / 48	INCLUDED	
#365884	84T / 48	OPTION	
#365887	87T / 48	OPTION	

BAG

02

- 32 3014 COMPOSITE FRONT-MID MOTOR GEAR BOX (3 GEARS) SET
- 32 4012 ALU FRONT-MID MOTOR (3 GEARS) PLATE - SWISS 7075 T6
- 32 4110 ALU TOP SHAFT 20T - SWISS 7075 T6 - HARD COATED
- 32 4120 ALU 3-PAD SLIPPER CLUTCH PLATE - SWISS 7075 T6
- 32 4121 ALU 3-PAD SLIPPER CLUTCH PLATE WITH ADAPTER
- 32 4190 ALU 3-PAD SLIPPER CLUTCH SHIM
- 32 4236 COMPOSITE GEAR 36T - GRAPHITE
- 36 4131 SLIPPER CLUTCH PAD "SLS" - V2 (2)
- 36 4140 ALU 3-PAD SLIPPER CLUTCH PLATE DISC - 7075 T6
- 36 4180 SLIPPER CLUTCH SPRING C=30 - BLACK
- 36 5875 COMPOSITE 3-PAD SLIPPER CLUTCH SPUR GEAR 75T / 48 (OPTION)
- 36 5878 COMPOSITE 3-PAD SLIPPER CLUTCH SPUR GEAR 78T / 48 (OPTION)
- 36 5881 COMPOSITE 3-PAD SLIPPER CLUTCH SPUR GEAR 81T / 48
- 36 5884 COMPOSITE 3-PAD SLIPPER CLUTCH SPUR GEAR 84T / 48 (OPTION)

- 36 5887 COMPOSITE 3-PAD SLIPPER CLUTCH SPUR GEAR 87T / 48 (OPTION)
- 90 2310 HEX SCREW SH M3x10 (10)
- 90 2316 HEX SCREW SH M3x16 (10)
- 90 2320 HEX SCREW SH M3x20 (10)
- 90 3308 HEX SCREW SFH M3x8 (10)
- 93 0308 BALL-BEARING 3x8x4 (2)
- 94 0512 HIGH-SPEED BALL-BEARING 5x12x4 RUBBER SEALED (2)
- 94 0613 HIGH-SPEED BALL-BEARING 6x13x5 RUBBER SEALED (2)
- 96 0040 NUT M4 (10)
- 98 0320 PIN 3x20 (10)
- 98 1310 PIN 3x10 (10)

32 4900 GEAR DIFFERENTIAL - SET



981310
P 3x10



980320
P 3x20

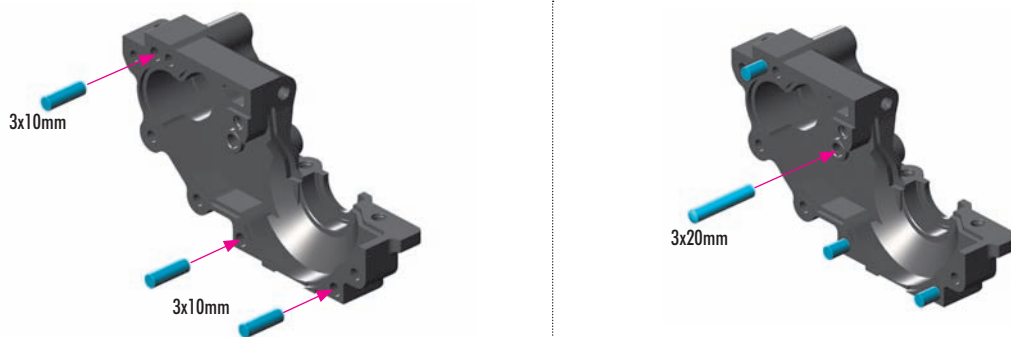

940613
BB 6x13x5



940613
BB 6x13x5

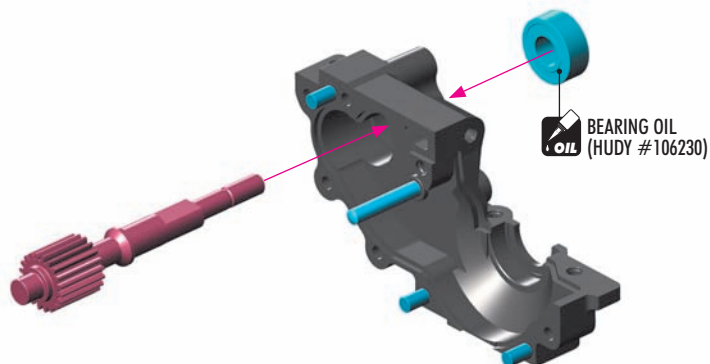

2. REAR TRANSMISSION



930308
BB 3x8x4

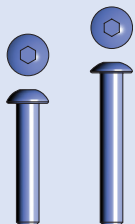
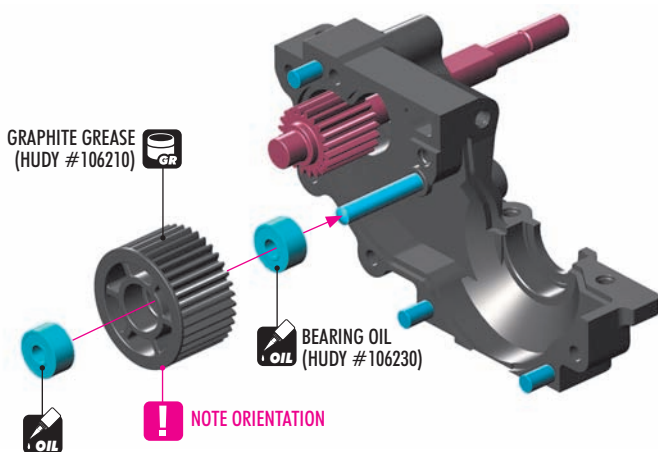

902316
SH M3x16

902320
SH M3x20

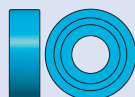

940512
BB 5x12x4

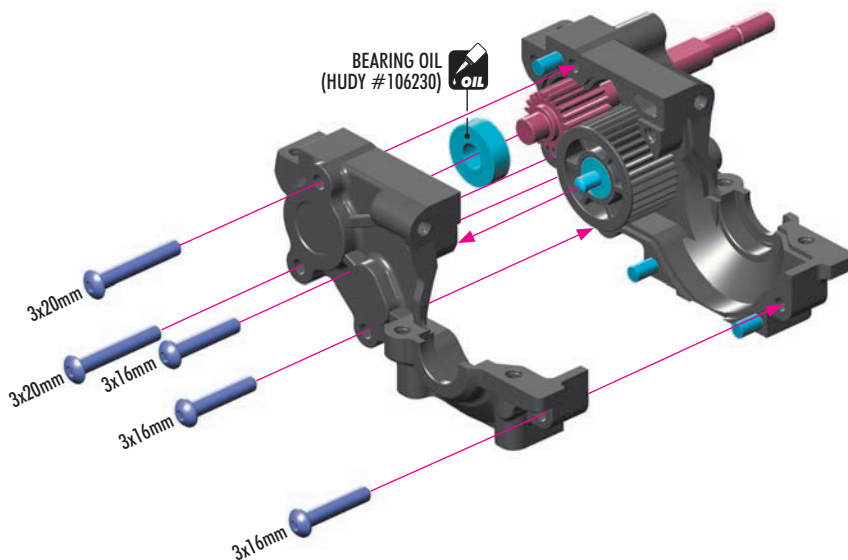

902310
SH M3x10

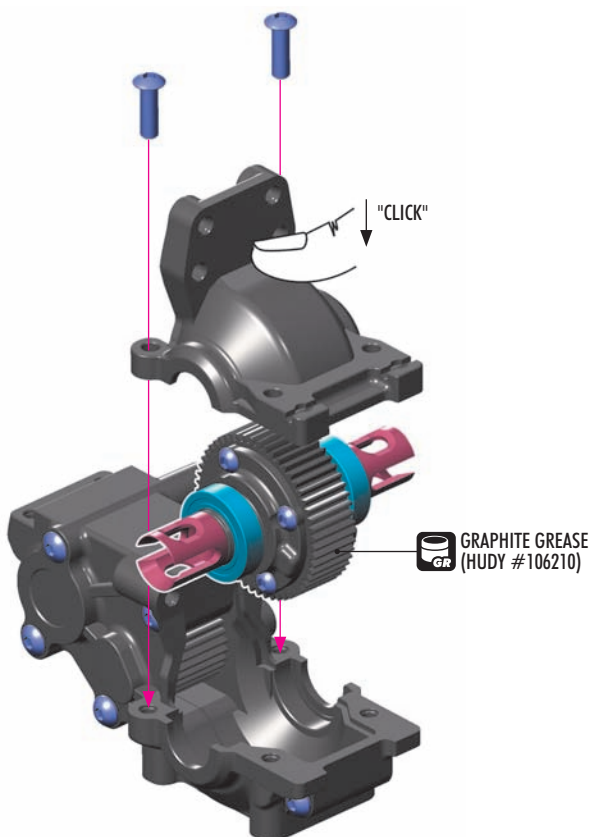

2. REAR TRANSMISSION

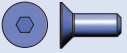

903308
SFH M3x8

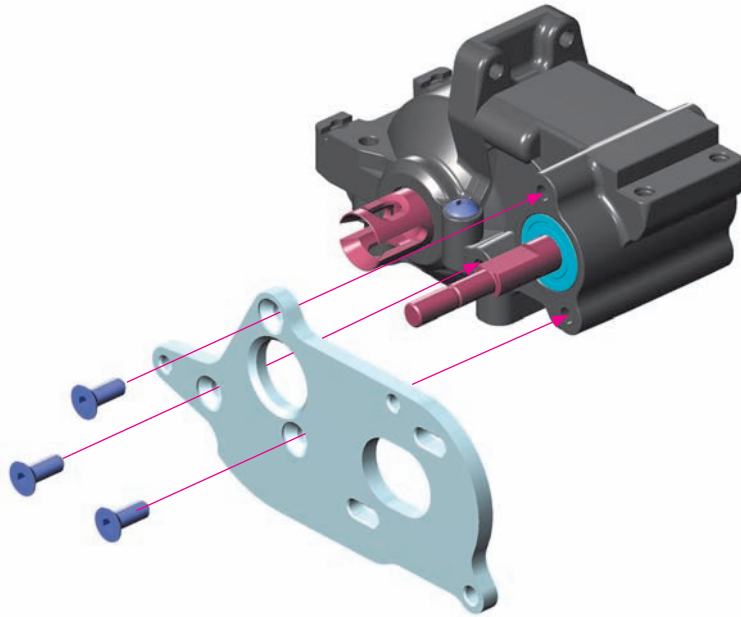

NOTE ORIENTATION !

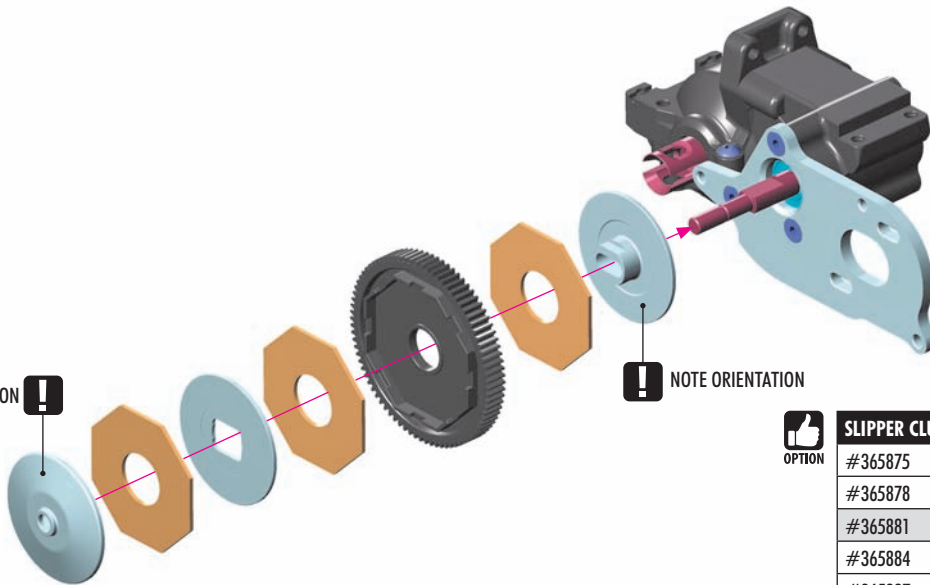

NOTE ORIENTATION !



SLIPPER CLUTCH SPUR GEARS

#365875	75T / 48	OPTION
#365878	78T / 48	OPTION
#365881	81T / 48	INCLUDED
#365884	84T / 48	OPTION
#365887	87T / 48	OPTION



960040
N M4

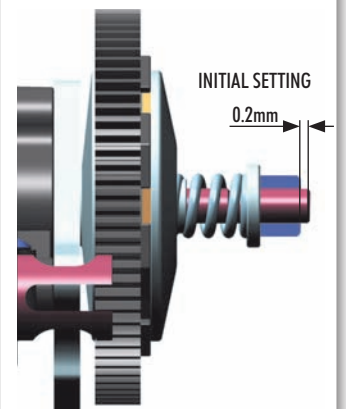
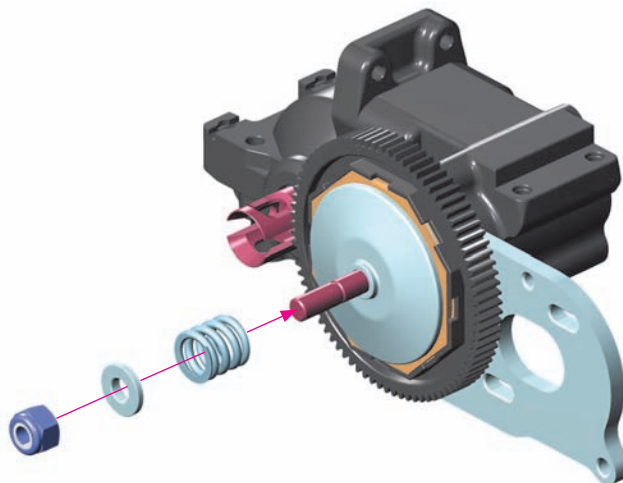

3. REAR SUSPENSION

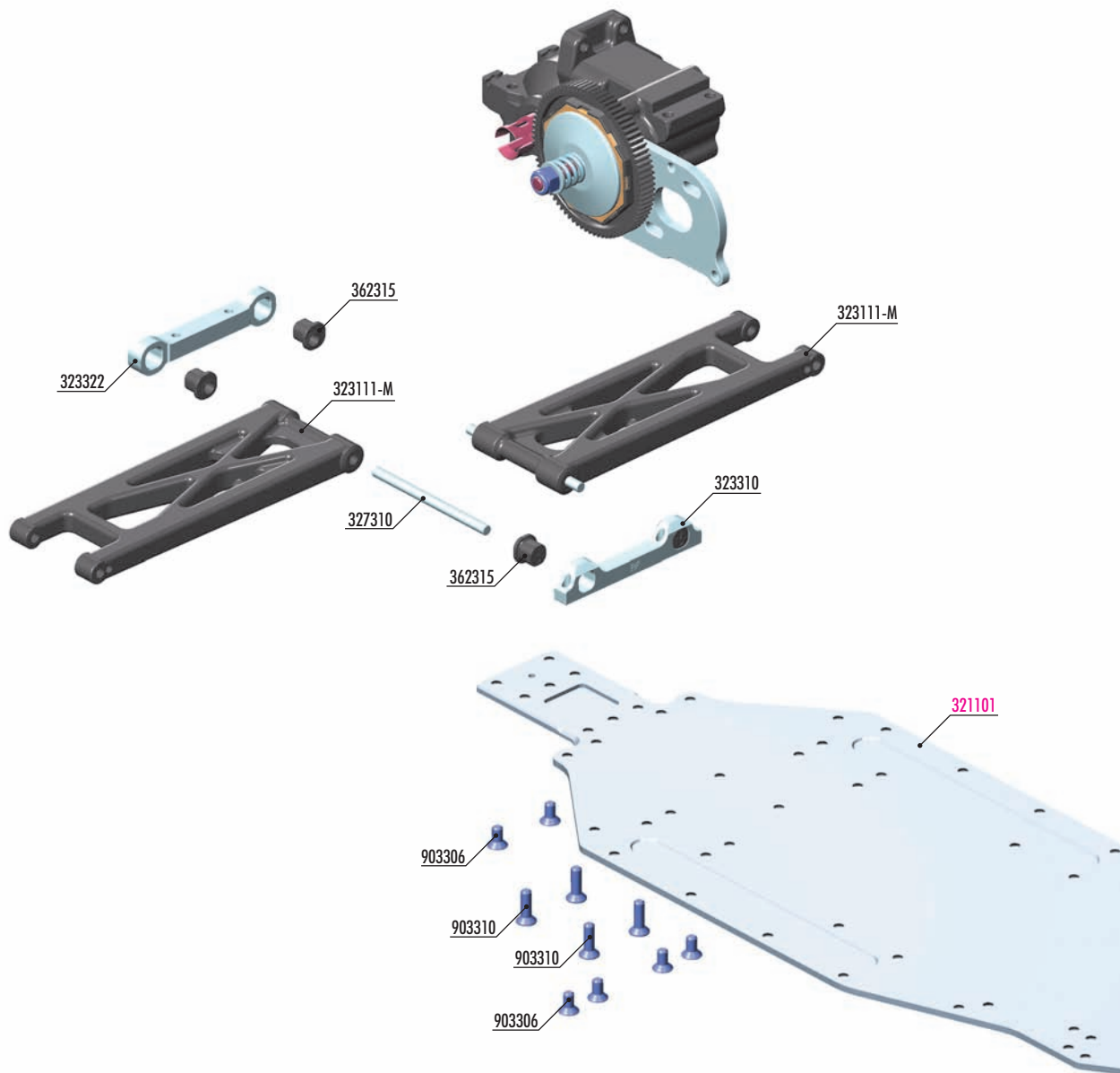

REAR LOWER SUSPENSION HOLDERS

#	MATERIAL	TYPE	STATUS
#323310	ALU	RF	INCLUDED
#323311	BRASS	RF	OPTION
#323321	BRASS	RR	OPTION
#323322	ALU	RR	INCLUDED



REAR SUSPENSION ARMS

#	MATERIAL	STATUS
#323111-M	MEDIUM	INCLUDED
#323111-H	HARD	OPTION
#323111-G	GRAPHITE	OPTION

BAG

03

32 3082-H	XT2 COMPOSITE SHOCK TOWER REAR - HARD	36 2315	ECCENTRIC BUSHING SET (2)
32 3111-M	COMPOSITE SUSPENSION ARM REAR LOWER RIGHT - MEDIUM	90 2310	HEX SCREW SH M3x10 (10)
32 3111-G	XT2 COMPOSITE SUSPENSION ARM REAR LOWER - GRAPHITE (OPTION)	90 2322	HEX SCREW SH M3x22 (10)
32 3111-H	COMPOSITE SUSPENSION ARM REAR LOWER RIGHT - HARD (OPTION)	90 2335	HEX SCREW SH M3x35 (10)
32 3310	ALU REAR LOWER SUSP. HOLDER - FRONT - SWISS 7075 T6 (5MM)	90 3306	HEX SCREW SFH M3x6 (10)
32 3311	BRASS REAR LOWER SUSP. HOLDER - FRONT (OPTION)	90 3310	HEX SCREW SFH M3x10 (10)
32 3321	BRASS REAR LOWER SUSP. HOLDER - REAR (OPTION)		
32 3322	ALU REAR LOWER SUSP. HOLDER - REAR - SWISS 7075 T6 (5MM)		
32 3550	COMPOSITE REAR SHOCK TOWER ADJUSTING SHIM	32 1101	XT2 ALU CHASSIS - SWISS 7075 T6 (2MM)
32 3551	XT2 COMPOSITE REAR BODY MOUNT (2)		
32 7310	REAR SUSPENSION PIVOT PIN (2)		

3. REAR SUSPENSION

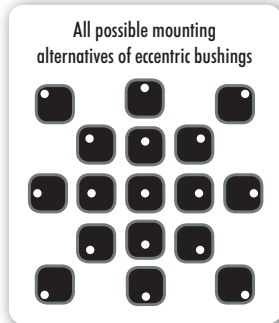
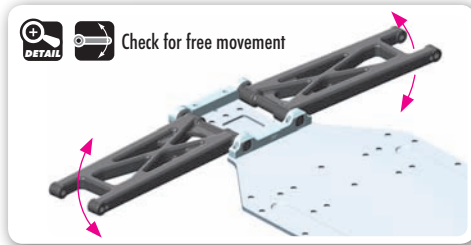
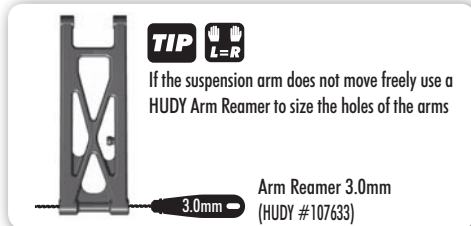
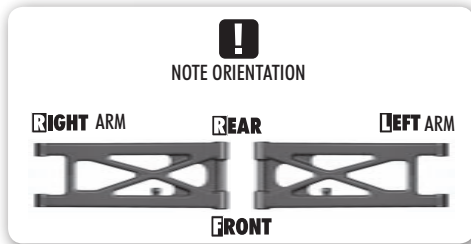
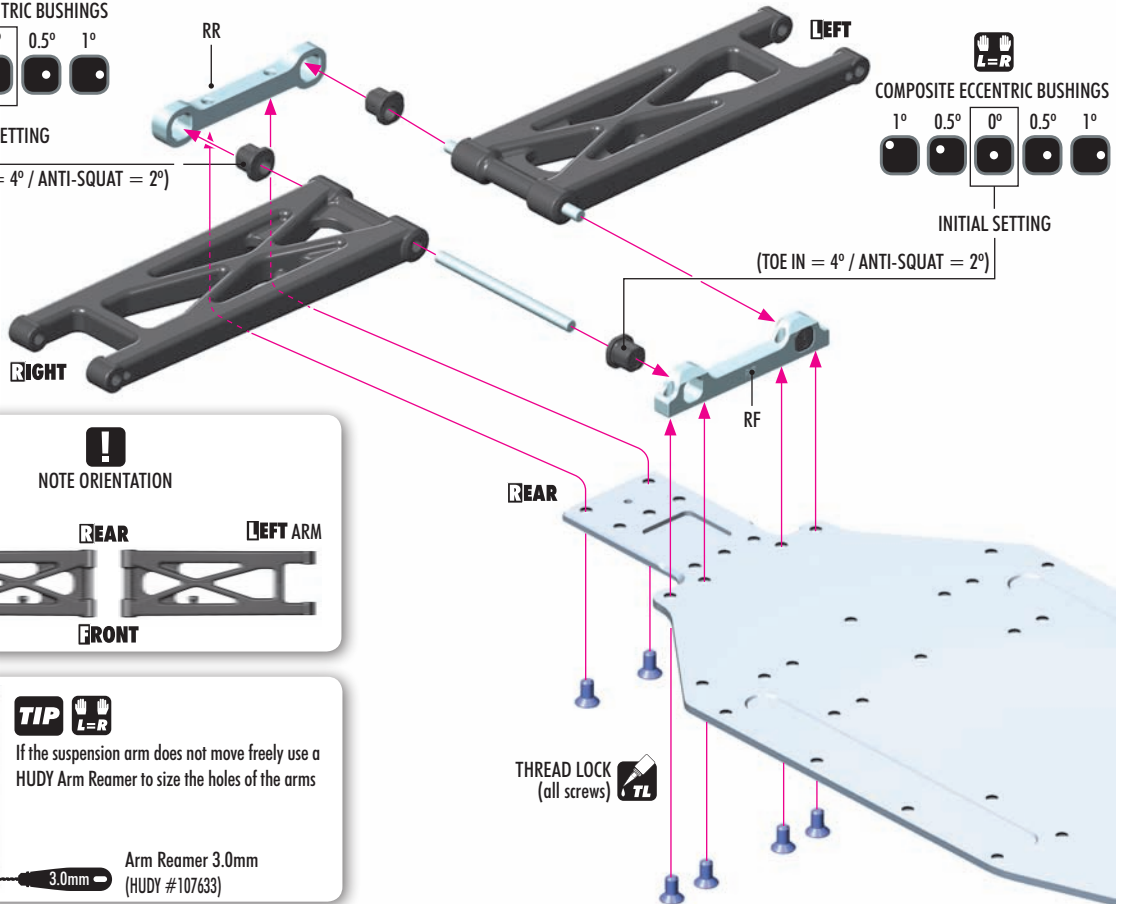
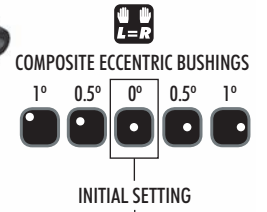
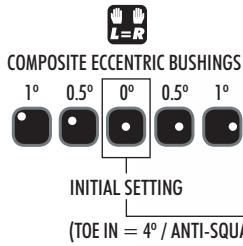

REAR LOWER SUSPENSION HOLDERS

OPTION	Part #	Material	Orientation	Status
	#323310	ALU	RF	INCLUDED
	#323311	BRASS	RF	OPTION
	#323321	BRASS	RR	OPTION
	#323322	ALU	RR	INCLUDED

REAR SUSPENSION ARMS

OPTION	Part #	Material	Status
	#323111-M	MEDIUM	INCLUDED
	#323111-H	HARD	OPTION
	#323111-G	GRAPHITE	OPTION

MEDIUM - For very-low & low traction
 HARD - For medium & high traction
 GRAPHITE - For high & very-high traction

SET-UP BOOK

TOE-IN
 ANTI-SQUAT
 ROLL CENTER
 TRACK-WIDTH

ECCENTRIC BUSHINGS HAVE TWO DIFFERENT OFFSETS FROM THE CENTER.

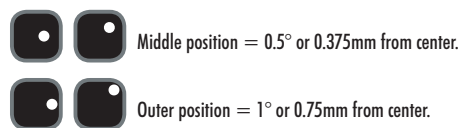

ANTI-SQUAT

RR	RF	(°)
0	0	= 2°
0	0	= 3°
0	0	= 1°
0	0	= 3°
0	0	= 2°
0	0	= 4°
0	0	= 1°
0	0	= 2°
0	0	= 0°

ROLL CENTER

RR	RF	(mm)
0	0	= +0.75mm
0	0	= 0mm
0	0	= -0.75mm

TRACK-WIDTH

RR	RF	(mm)
0	0	= +1.5mm
0	0	= 0mm
0	0	= -1.5mm

The track-width is directly influenced by the size of the wheels and tires used.

TOE-IN

RR	RF	(°)
0	0	= 4°
0	0	= 5°
0	0	= 3°
0	0	= 3°
0	0	= 4°
0	0	= 2°
0	0	= 5°
0	0	= 6°
0	0	= 4°

The tables describe the amounts of adjustment using the center and outside positions of the eccentric bushings. The middle position eccentric bushings allow for finer adjustment increments.

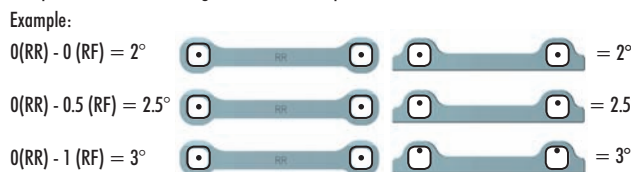

3. REAR SUSPENSION



903310
SFH M3x10

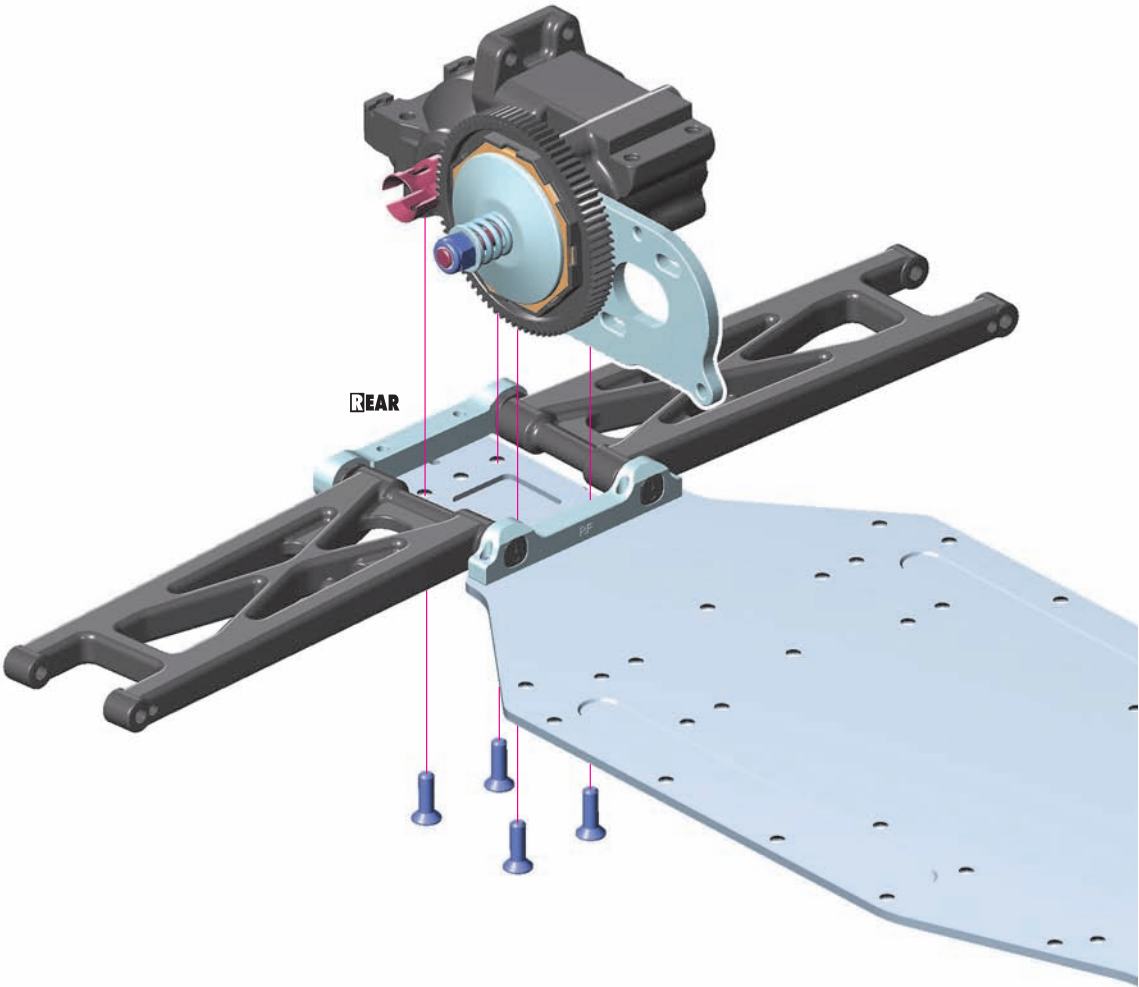

3. REAR DRIVETRAIN



DRIVE SHAFT COLLAR		
#365470	COMPOSITE	INCLUDED
#365471-K	ALU - BLACK	OPTION
#365471-O	ALU - ORANGE	OPTION



REAR UPRIGHTS		
#323350-M	MEDIUM	OPTION
#323350-H	HARD	INCLUDED
#323351	ALU	OPTION



WHEEL HUBS 12MM		
#365359	+3.75mm - 5 slots	OPTION
#365358	+3.0mm - 4 slots	INCLUDED
#365357	+2.25mm - 3 slots	OPTION
#365356	+1.5mm - 2 slots	OPTION
#365355	+0.75mm - 1 slot	OPTION
#365353	0mm - 0 slots	OPTION
#365354	-0.75mm - Lightw.	OPTION



REAR ROLL CENTER HOLDER		
#323040	COMPOSITE	INCLUDED
#323041	ALU	OPTION



#362400
ANTI-ROLL BAR 1.0MM SET
901306

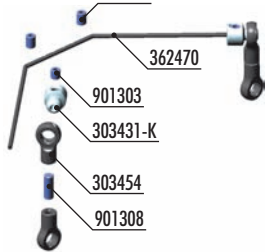

REAR ANTI-ROLL BARS

#362470	1.0mm
#362471	1.1mm
#362472	1.2mm
#362473	1.3mm
#362474	1.4mm
#362476	1.6mm
#362478	1.8mm
#362480	2.0mm

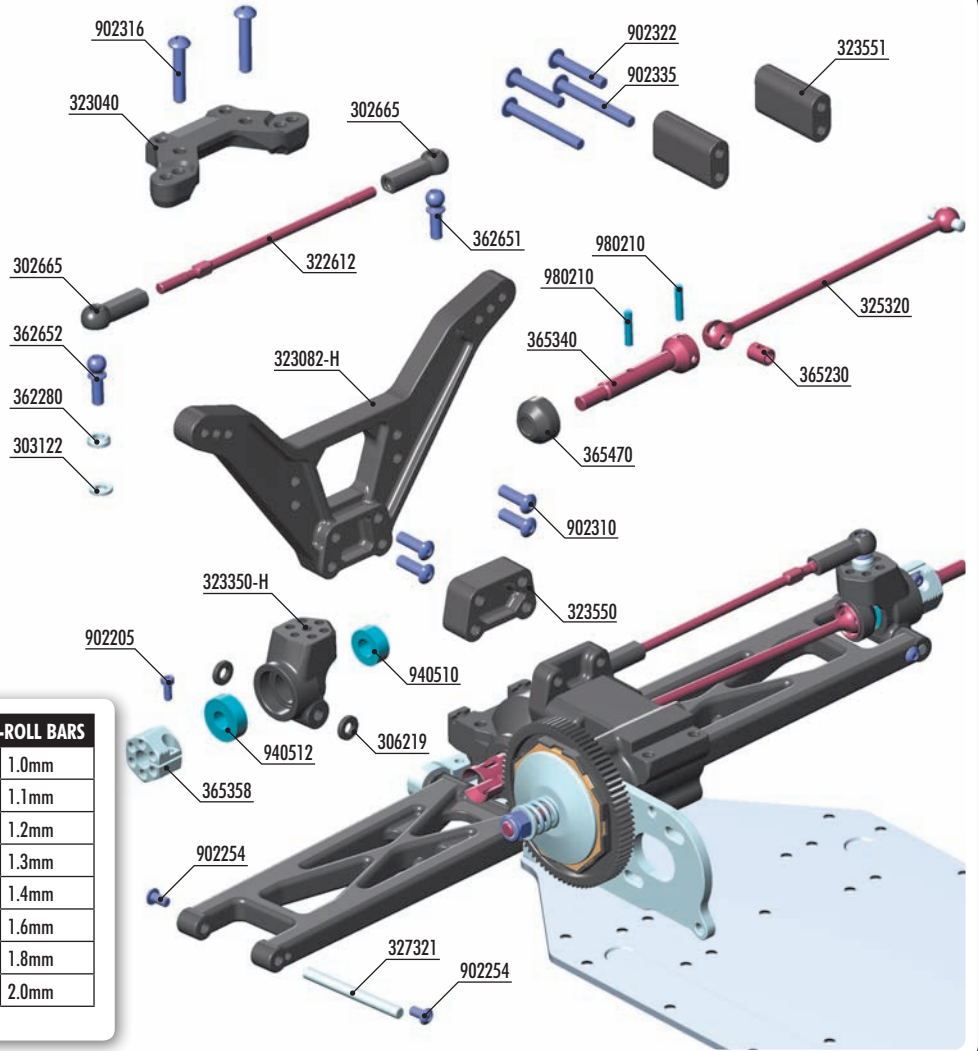

30 2665	COMPOSITE BALL JOINT 4.9MM - CLOSED WITH HOLE (4)	36 2476	ANTI-ROLL BAR 1.6 MM (OPTION)
30 3122	ALU SHIM 3x6x1.0MM (10)	36 2478	ANTI-ROLL BAR 1.8 MM (OPTION)
30 3431-K	ALU 4.9MM BALL END - BLACK (2) (OPTION)	36 2480	ANTI-ROLL BAR 2.0 MM (OPTION)
30 3454	BALL JOINT 4.9MM - OPEN (4) (OPTION)	36 2651	BALL END 4.9MM WITH THREAD 8MM (2)
30 6219	COMPOSITE SET OF SERVO SHIMS (4)	36 2652	BALL END 4.9MM WITH THREAD 10MM (2)
32 2612	ADJUSTABLE TURNBUCKLE 75MM M3 L/R - HUDY SPRING STEEL™ (2)	36 5230	DRIVE SHAFT COUPLING - HUDY SPRING STEEL™
32 3040	COMPOSITE REAR ROLL CENTER HOLDER - CARPET EDITION	36 5340	REAR DRIVE AXLE - HUDY SPRING STEEL™
32 3041	ALU REAR ROLL CENTER HOLDER - SWISS 7075 T6 (OPTION)	36 5358	ALU WHEEL HUB 12MM - OFFSET "+3.0MM" (2)
32 3350-M	COMPOSITE UPRIGHT REAR - MEDIUM (OPTION)	36 5470	COMPOSITE DRIVE SHAFT SAFETY COLLAR - V2 (3)
32 3350-H	COMPOSITE UPRIGHT REAR - HARD		
32 3351	ALU REAR UPRIGHT - SWISS 7075 T6 (OPTION)	90 1303	HEX SCREW SB M3x3 (10) (OPTION)
32 5320	REAR DRIVE SHAFT 90MM - HUDY SPRING STEEL™	90 1306	HEX SCREW SB M3x6 (10) (OPTION)
32 7321	REAR ARM PIVOT PIN (2)	90 1308	HEX SCREW SB M3x8 (10) (OPTION)
36 2280	ALU CONICAL SHIM 3x6x2.0MM (10)	90 2205	HEX SCREW SH M2x5 (10)
36 2400	ANTI-ROLL BAR 1.0MM SET (OPTION)	90 2254	HEX SCREW SH M2.5x4 (10)
36 2470	ANTI-ROLL BAR 1.0 MM (OPTION)	90 2316	HEX SCREW SH M3x16 (10)
36 2471	ANTI-ROLL BAR 1.1 MM (OPTION)	94 0510	HIGH-SPEED BALL-BEARING 5x10x4 RUBBER SEALED (2)
36 2472	ANTI-ROLL BAR 1.2 MM (OPTION)	94 0512	HIGH-SPEED BALL-BEARING 5x12x4 RUBBER SEALED (2)
36 2473	ANTI-ROLL BAR 1.3 MM (OPTION)	98 0210	PIN 2x9.8 (10)
36 2474	ANTI-ROLL BAR 1.4 MM (OPTION)		

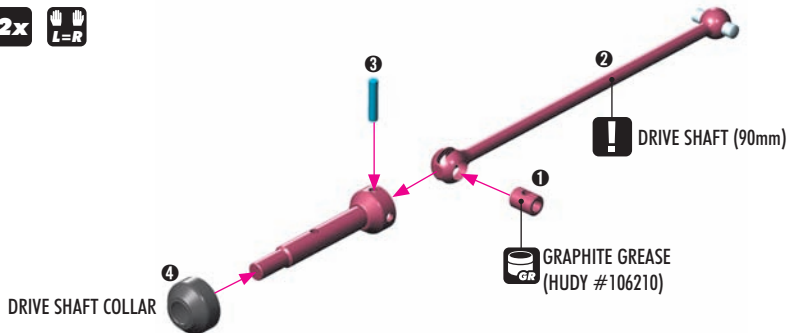
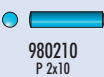

DRIVE SHAFT COLLAR		
#365470	COMPOSITE	INCLUDED
#365471-K	ALU - BLACK	OPTION
#365471-O	ALU - ORANGE	OPTION

3. REAR DRIVETRAIN

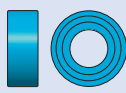

940510
BB 5x10x4



940512
BB 5x12x4

2x



OPTION

REAR UPRIGHTS

Part #	Material	Status
#323350-M	MEDIUM	OPTION
#323350-H	HARD	INCLUDED
#323351	ALU	OPTION

MEDIUM - For very-low & low traction
 HARD - For medium & high traction
 ALU - For very-high traction



980210
P 2x10



902205
SH M2x5

2x

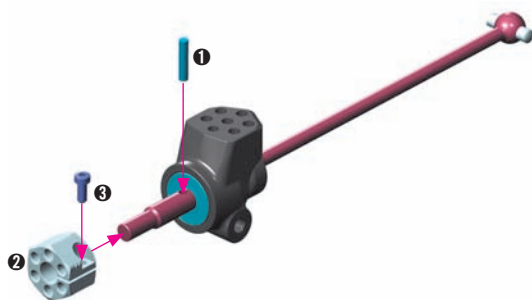

OPTION

WHEEL HUBS 12MM

Part #	Offset	Slots	Status
#365359	+3.75mm	- 5 slots	OPTION
#365358	+3.0mm	- 4 slots	INCLUDED
#365357	+2.25mm	- 3 slots	OPTION
#365356	+1.5mm	- 2 slots	OPTION
#365355	+0.75mm	- 1 slot	OPTION
#365353	0mm	- 0 slots	OPTION
#365354	-0.75mm	- Lightw.	OPTION

OPTIONAL HEX HUB EFFECTS

Different off-set hex hubs are used to increase or decrease the track-width.

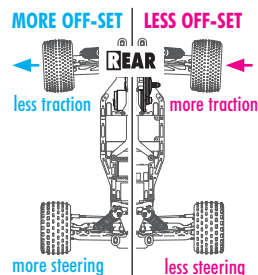

902316
SH M3x16

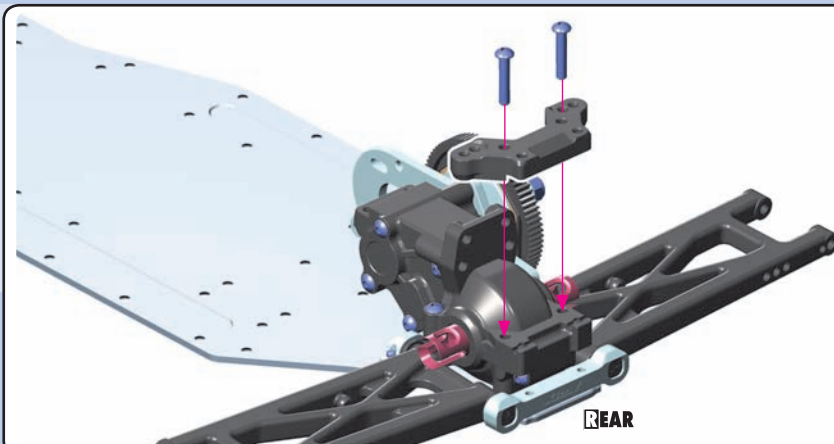

OPTION

REAR ROLL CENTER HOLDER

Part #	Material	Status
#323040	COMPOSITE	INCLUDED
#323041	ALU	OPTION

COMPOSITE - For low, medium & high traction
 ALU - For very-high traction



306219
SHIM 3x6x2



902254
SH M2.5x4

TIP Ensure that the rear upright moves freely. If it does not move freely, use sandpaper to thin both wheelbase adjustment shims.

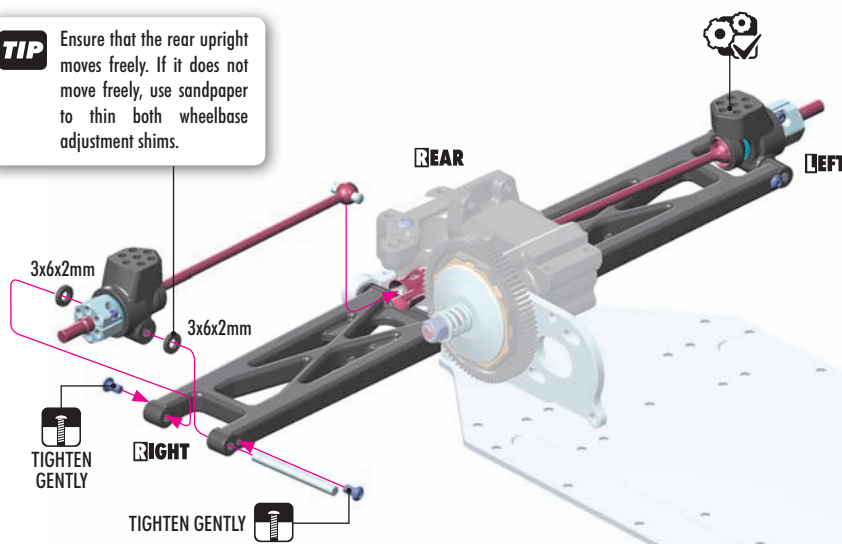

LONGER WHEELBASE (INITIAL SETTING)

Adjustment Shim **IN FRONT OF HUB** moves hub rearward.

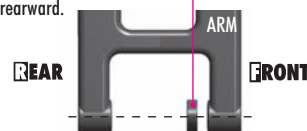

SHORTER WHEELBASE

Adjustment Shim **BEHIND HUB** moves hub forward.

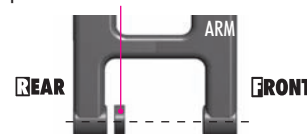

DETAILS

Check for free movement



3. REAR DRIVETRAIN

2x **L=R**

NOTE ORIENTATION !

RIGHT THREAD

LEFT THREAD

10mm THREAD

8mm THREAD

2x **L=R**

56mm

303122
SHIM 3x6x1

362280
CON. SHIM 3x6x2

2x **L=R**

NOTE ORIENTATION !

NOTE ORIENTATION !

8mm THREAD

10mm THREAD

CONICAL SHIM 3x6x2mm

3x6x1mm

INITIAL SETTING

INITIAL SETTING

L=R

L=R

902310
SH M3x10

NOTE ORIENTATION !

NOTE ORIENTATION !

REAR

Larger diameter hole

L=R

902322
SH M3x22

902335
SH M3x35

REAR

3x22mm

3x35mm

3x22mm

3x35mm

4. FRONT ASSEMBLY



FRONT LOWER ARM MOUNT		
#322310	ALU 26°	OPTION
#322311	COMPOSITE 26°	INCLUDED
#322312	BRASS 26°	OPTION
#322313	ALU 23°/29°	OPTION
#321211	SUSP. HOLDER BRACE 23°/29°	OPTION
#322314	BRASS 23°/29°	OPTION
#321211	SUSP. HOLDER BRACE 23°/29°	OPTION

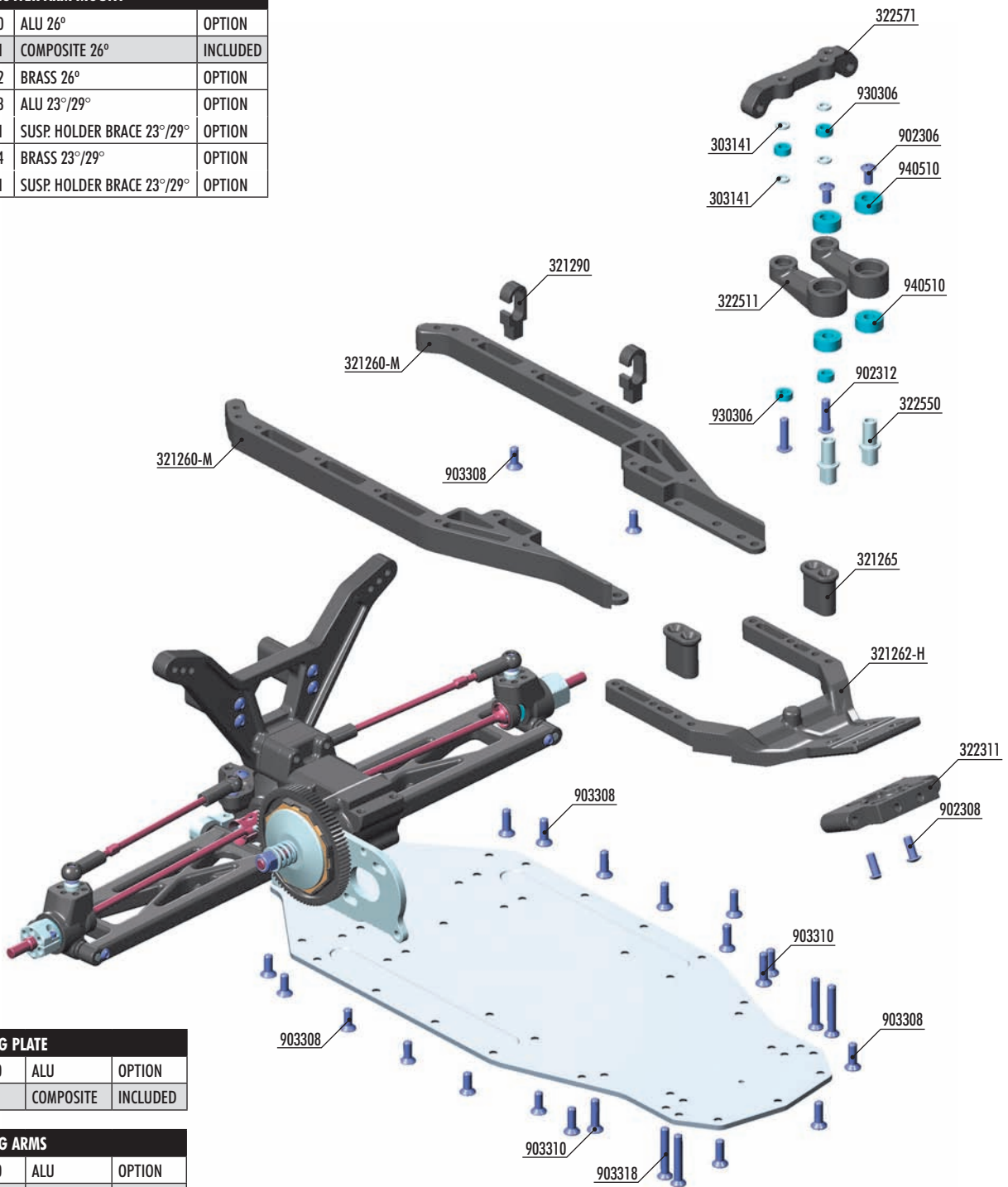

STEERING PLATE		
#322570	ALU	OPTION
#322571	COMPOSITE	INCLUDED



STEERING ARMS		
#322510	ALU	OPTION
#322511	COMPOSITE	INCLUDED



FRONT LOWER CHASSIS BRACE		
#321262-M	MEDIUM	OPTION
#321262-H	HARD	INCLUDED



SIDE CHASSIS GUARDS		
#321260-M	MEDIUM	INCLUDED
#321260-H	HARD	OPTION

BAG

04

- 30 3141 ALU SHIM 3x5x1.0MM (10)
- 32 1260-M COMPOSITE CHASSIS SIDE GUARDS L + R - MEDIUM
- 32 1260-H COMPOSITE CHASSIS SIDE GUARDS L + R - HARD (OPTION)
- 32 1262-M COMPOSITE CHASSIS FRONT GUARD - MEDIUM (OPTION)
- 32 1262-H COMPOSITE CHASSIS FRONT GUARD - HARD
- 32 1265 COMPOSITE FRONT CHASSIS SIDE BRACE (2)
- 32 1290 COMPOSITE WIRE HOLDER (2)
- 32 2310 ALU FRONT LOWER ARM MOUNT 26° KICK-UP (OPTION)
- 32 2311 COMPOSITE FRONT LOWER SUSPENSION HOLDER
- 32 2312 BRASS 46G FRONT LOWER ARM MOUNT 26° KICK-UP (OPTION)
- 32 2313 ALU FRONT LOWER ARM MOUNT 23°/29° KICK-UP (OPTION)
- 32 2314 BRASS 46G LOWER FRONT ARM MOUNT 23°/29° KICK-UP (OPTION)
- 32 2570 ALU STEERING PLATE - SWISS 7075 T6 (OPTION)

- 32 2571 COMPOSITE STEERING PLATE
- 32 2510 ALU STEERING ARM (2) (OPTION)
- 32 2511 COMPOSITE STEERING ARM (2)
- 32 2550 ALU SERVO SAVER PIVOT SHAFT (2)
- 90 2306 HEX SCREW SH M3x6 (10)
- 90 2308 HEX SCREW SH M3x8 (10)
- 90 2312 HEX SCREW SH M3x12 (10)
- 90 3308 HEX SCREW SFH M3x8 (10)
- 90 3310 HEX SCREW SFH M3x10 (10)
- 90 3318 HEX SCREW SFH M3x18 (10)
- 93 0306 BALL-BEARING 3x6x2.5 (2)
- 94 0510 HIGH-SPEED BALL-BEARING 5x10x4 RUBBER SEALED (2)

4. FRONT ASSEMBLY

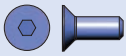

903308
SFH M3x8

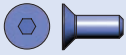
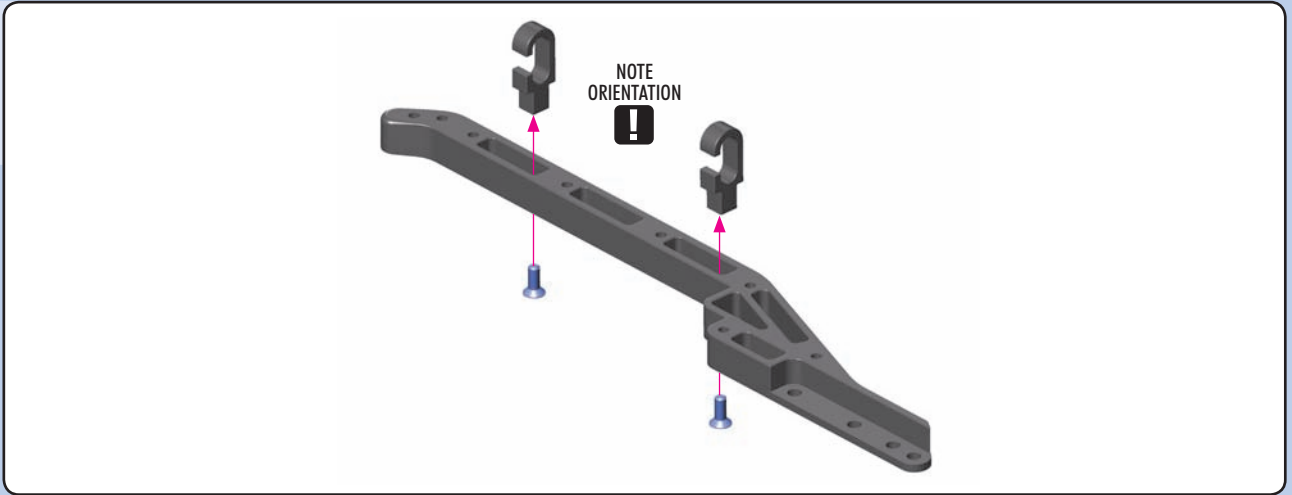

903308
SFH M3x8

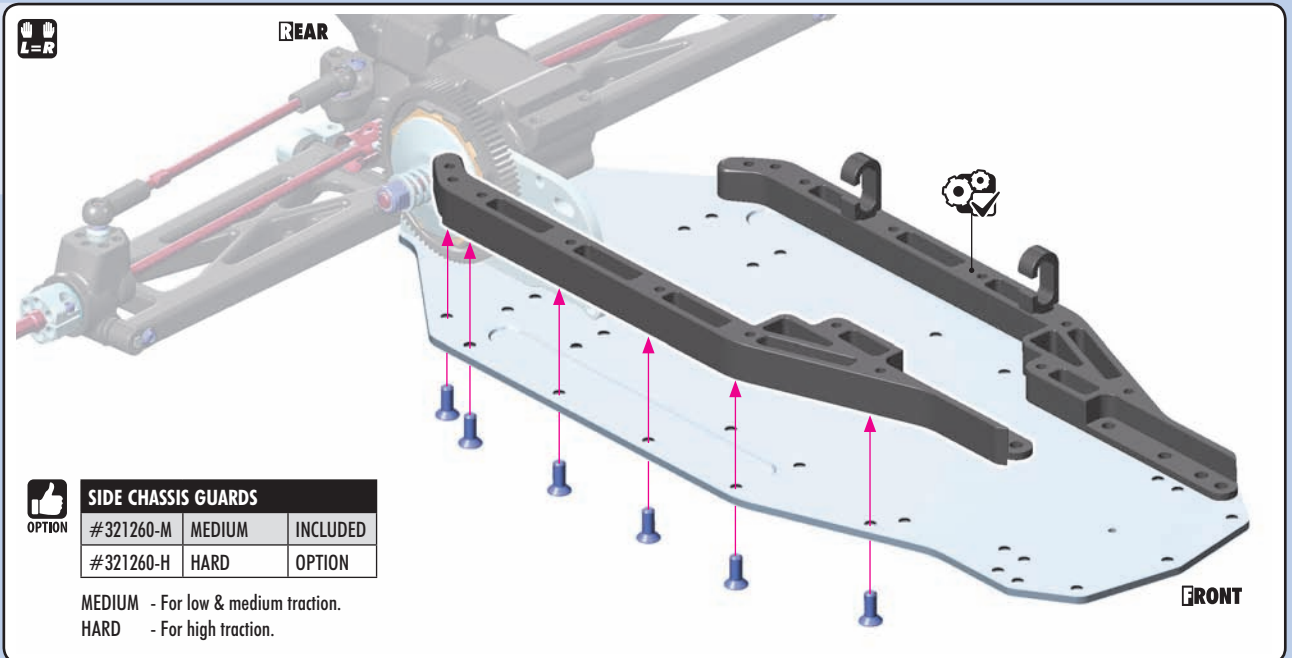

SIDE CHASSIS GUARDS

#321260-M	MEDIUM	INCLUDED
#321260-H	HARD	OPTION

MEDIUM - For low & medium traction.
HARD - For high traction.

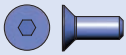

903308
SFH M3x8

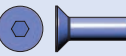

903310
SFH M3x10



903318
SFH M3x18

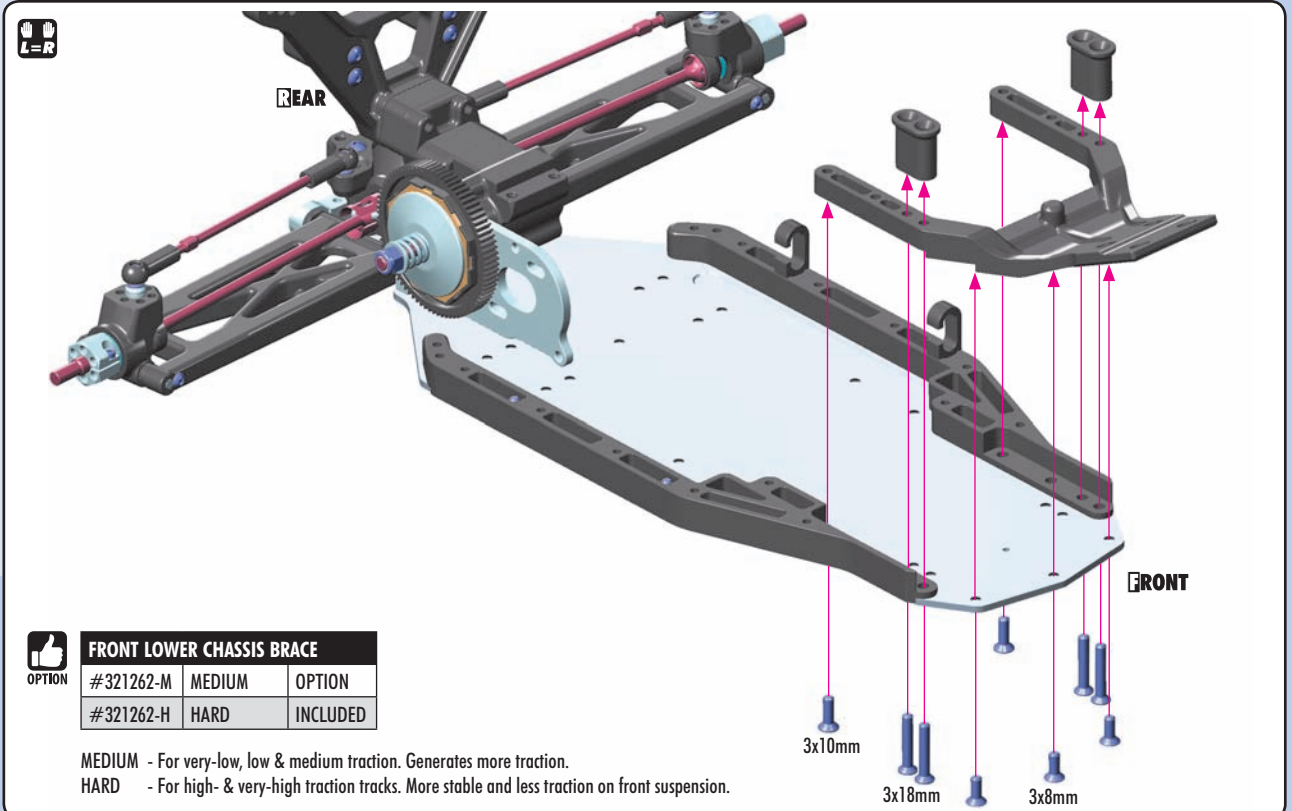

FRONT LOWER CHASSIS BRACE

#321262-M	MEDIUM	OPTION
#321262-H	HARD	INCLUDED

MEDIUM - For very-low, low & medium traction. Generates more traction.
HARD - For high- & very-high traction tracks. More stable and less traction on front suspension.

3x10mm

3x18mm

3x8mm

4. FRONT ASSEMBLY



303141
SHIM 3x5x1



902312
SH M3x12



930306
BB 3x6x2.5



STEERING PLATE

#322570	ALU	OPTION
#322571	COMPOSITE	INCLUDED

COMPOSITE - Easy to drive, more forgiving, less steering.
ALU - More aggressive, more steering, more precise steering.



STEERING ARMS

#322510	ALU	OPTION
#322511	COMPOSITE	INCLUDED

COMPOSITE - Easy to drive and more forgiving.
ALU - More aggressive, more precise steering.

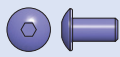
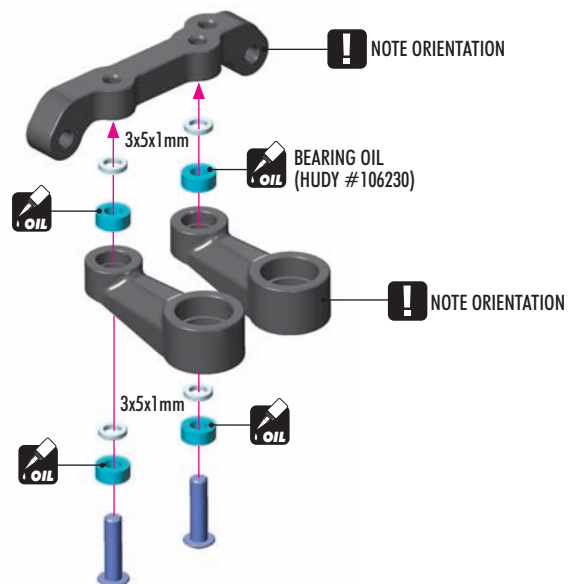

902306
SH M3x6

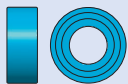

940510
BB 5x10x4

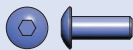
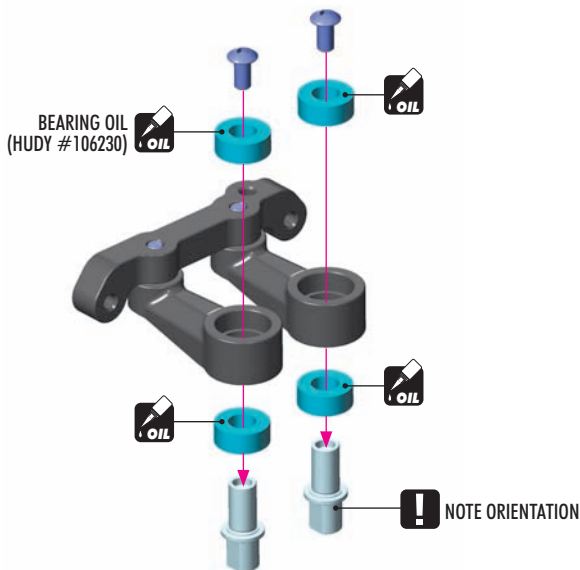

902308
SH M3x8



FRONT LOWER ARM MOUNT

#322310	ALU 26°	OPTION
#322311	COMPOSITE 26°	INCLUDED
#322312	BRASS 26°	OPTION
#322313	ALU 23°/29°	OPTION
#321211	SUSP. HOLDER BRACE 23°/29°	OPTION
#322314	BRASS 23°/29°	OPTION
#321211	SUSP. HOLDER BRACE 23°/29°	OPTION

COMPOSITE - Generates more traction in front.
ALU - Makes car more stable.
BRASS - Adds more weight in front, less weight transfer.

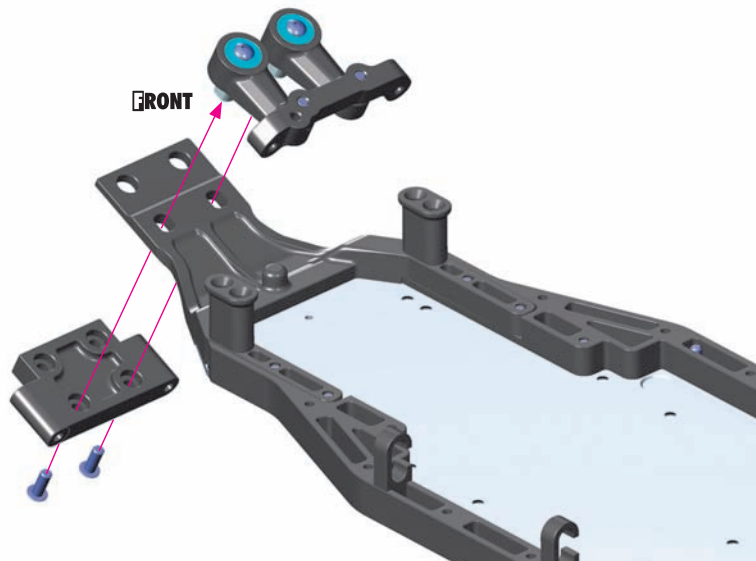

5. FRONT SUSPENSION

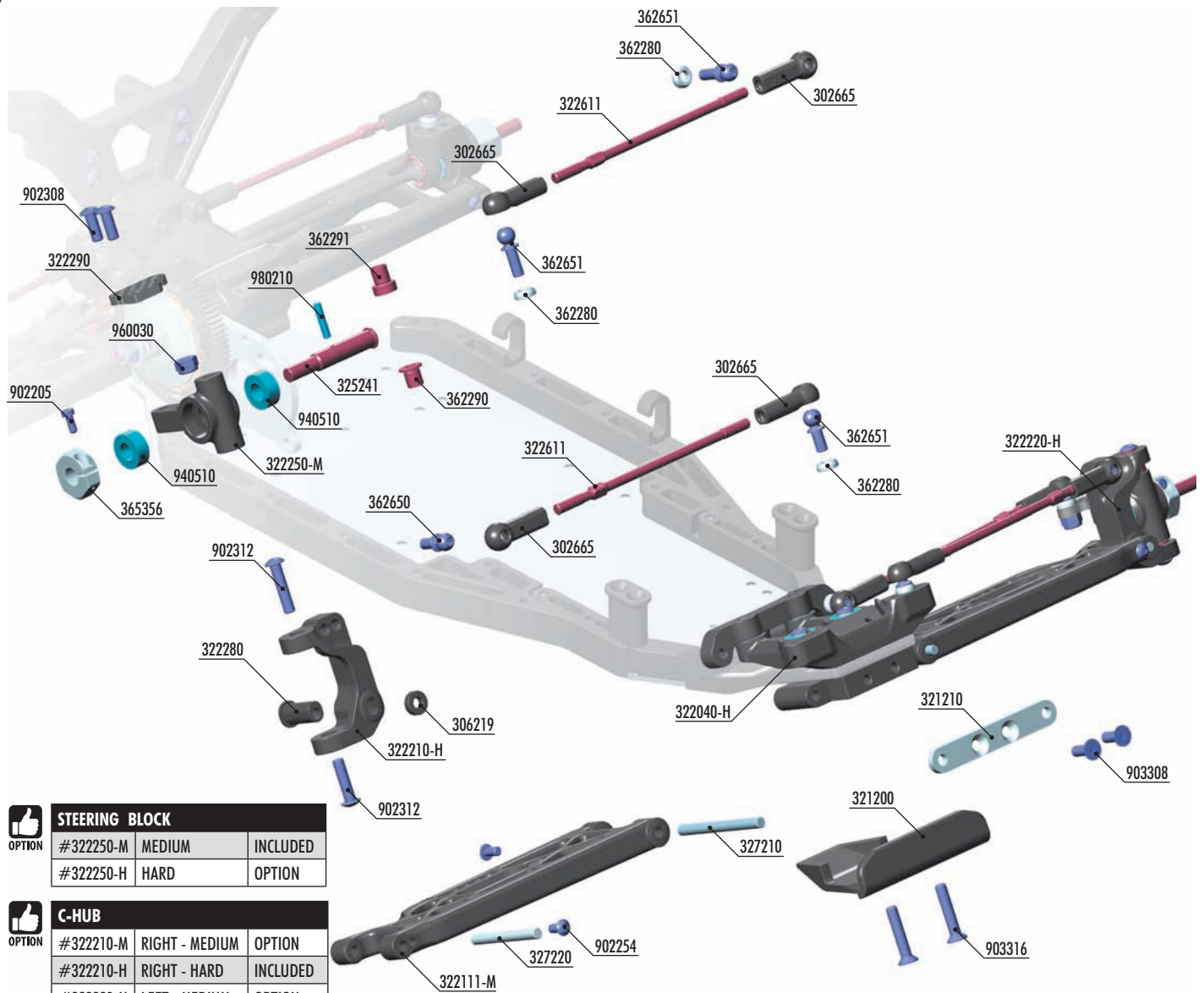

OPTION **STEERING BLOCK**

#322250-M	MEDIUM	INCLUDED
#322250-H	HARD	OPTION

OPTION **C-HUB**

#322210-M	RIGHT - MEDIUM	OPTION
#322210-H	RIGHT - HARD	INCLUDED
#322220-M	LEFT - MEDIUM	OPTION
#322220-H	LEFT - HARD	INCLUDED

OPTION **WHEEL HUBS 12MM**

#365359	+3.75mm - 5 slots	OPTION
#365358	+3.0mm - 4 slots	OPTION
#365357	+2.25mm - 3 slots	OPTION
#365356	+1.5mm - 2 slots	INCLUDED
#365355	+0.75mm - 1 slot	OPTION
#365353	0mm - 0 slots	OPTION
#365354	-0.75mm - Lightw.	OPTION

OPTION **SUSPENSION ARM**

#322111-M	MEDIUM	INCLUDED
#322111-H	HARD	OPTION
#322111-H	GRAPHITE	OPTION

OPTION **STEERING BLOCK EXTENSION**

#322290	2-SLOTS	INCLUDED
#322291	1-SLOT	OPTION
#322292	0-SLOTS	OPTION

OPTION **FRONT ROLL CENTER HOLDER**

#322040-M	MEDIUM	OPTION
#322040-H	HARD	INCLUDED
#322041	ALU	OPTION

BAG

05

- 30 2665 COMPOSITE BALL JOINT 4.9MM - CLOSED WITH HOLE (4)
- 30 6219 COMPOSITE SET OF SERVO SHIMS (4)
- 32 1200 COMPOSITE FRONT BUMPER
- 32 1210 ALU SUSPENSION HOLDER BRACE - SWISS 7075 T6 (3MM)
- 32 2040-M COMPOSITE FRONT ROLL CENTER HOLDER - MEDIUM (OPTION)
- 32 2040-H COMPOSITE FRONT ROLL CENTER HOLDER - HARD
- 32 2041 ALU FRONT ROLL CENTER HOLDER - SWISS 7075 T6 (OPTION)
- 32 2111-M COMPOSITE SUSPENSION ARM FRONT LOWER - MEDIUM
- 32 2111-G COMPOSITE SUSPENSION ARM FRONT LOWER - GRAPHITE (OPTION)
- 32 2111-H COMPOSITE SUSPENSION ARM FRONT LOWER - HARD (OPTION)
- 32 2210-M COMPOSITE C-HUB 0° DEG. RIGHT - MEDIUM (OPTION)
- 32 2210-H COMPOSITE C-HUB 0° DEG. RIGHT - HARD
- 32 2220-M COMPOSITE C-HUB 0° DEG. LEFT - MEDIUM (OPTION)
- 32 2220-H COMPOSITE C-HUB 0° DEG. LEFT - HARD
- 32 2250-M COMPOSITE STEERING BLOCK - MEDIUM
- 32 2250-H COMPOSITE STEERING BLOCK - HARD (OPTION)
- 32 2280 COMPOSITE CASTER ECCENTRIC BUSHING (2+2+2)
- 32 2290 GRAPHITE EXTENSION FOR STEERING BLOCK - 2 SLOTS (2)
- 32 2291 GRAPHITE EXTENSION FOR STEERING BLOCK - 1 SLOT (2) (OPTION)
- 32 2292 GRAPHITE EXTENSION FOR STEERING BLOCK - 0 SLOTS (2) (OPTION)

- 32 2611 ADJUSTABLE TURNBUCKLE 70MM M3 L/R - HUDY SPRING STEEL™ (2)
- 32 5241 XT2 FRONT DRIVE AXLE - HUDY SPRING STEEL™
- 32 7210 FRONT SUSPENSION PIVOT PIN (2)
- 32 7220 FRONT ARM PIVOT PIN (2)
- 36 2280 ALU CONICAL SHIM 3x6x2.0MM (10)
- 36 2290 STEEL STEERING BUSHING - SHORT (2)
- 36 2291 STEEL STEERING BUSHING - LONG (2)
- 36 2650 BALL END 4.9MM WITH THREAD 6MM (2)
- 36 2651 BALL END 4.9MM WITH THREAD 8MM (2)
- 36 5356 ALU WHEEL HUB 12MM - OFFSET " + 1.50MM" (2)
- 90 2205 HEX SCREW SH M2x5 (10)
- 90 2254 HEX SCREW SH M2.5x4 (10)
- 90 2308 HEX SCREW SH M3x8 (10)
- 90 2312 HEX SCREW SH M3x12 (10)
- 90 3308 HEX SCREW SFH M3x8 (10)
- 90 3316 HEX SCREW SFH M3x16 (10)
- 94 0510 HIGH-SPEED BALL-BEARING 5x10x4 RUBBER SEALED (2)
- 96 0030 NUT M3 (10)
- 98 0210 PIN 2x9.8 (10)

5. FRONT SUSPENSION



902254
SH M2.5x4

2x
L=R

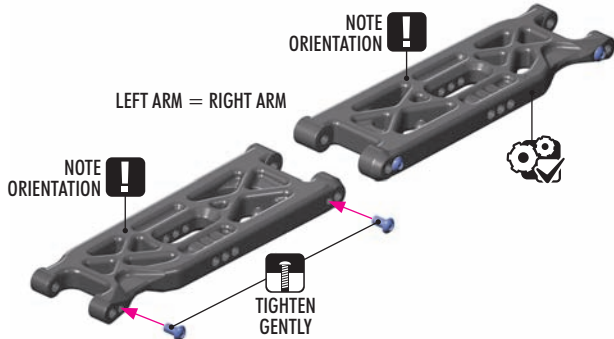

SUSPENSION ARM

OPTION	Part #	Material	Status
	#322111-M	MEDIUM	INCLUDED
	#322111-H	HARD	OPTION
	#322111-H	GRAPHITE	OPTION

MEDIUM - For very-low & low traction
 HARD - For medium & high traction
 GRAPHITE - For high & very-high traction



903308
SFH M3x8

L=R

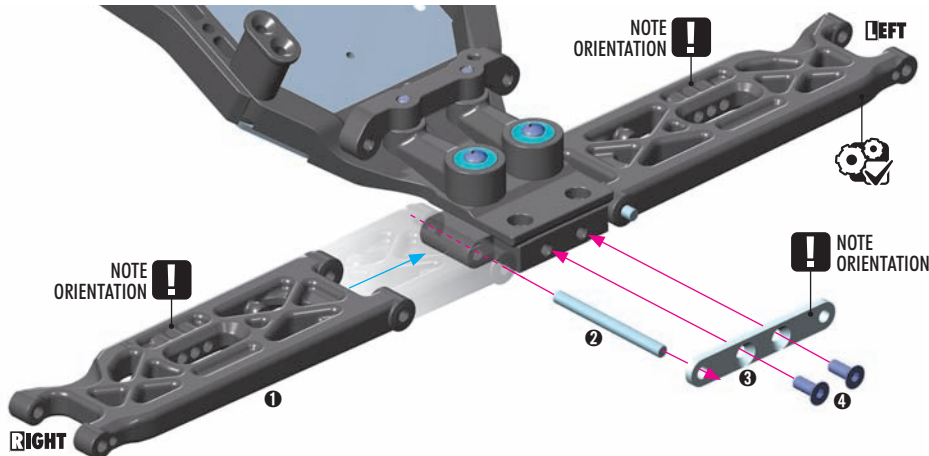

FRONT ROLL CENTER HOLDER

OPTION	Part #	Material	Status
	#322040-M	MEDIUM	OPTION
	#322040-H	HARD	INCLUDED
	#322041	ALU	OPTION

MEDIUM - Generates more traction, absorbs bumps better.

HARD - More precise, absorbs less bumps than medium but still more than alu, more reactive than medium composite but less than alu.

ALU - More precise and increased strength.



903316
SFH M3x16

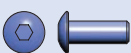
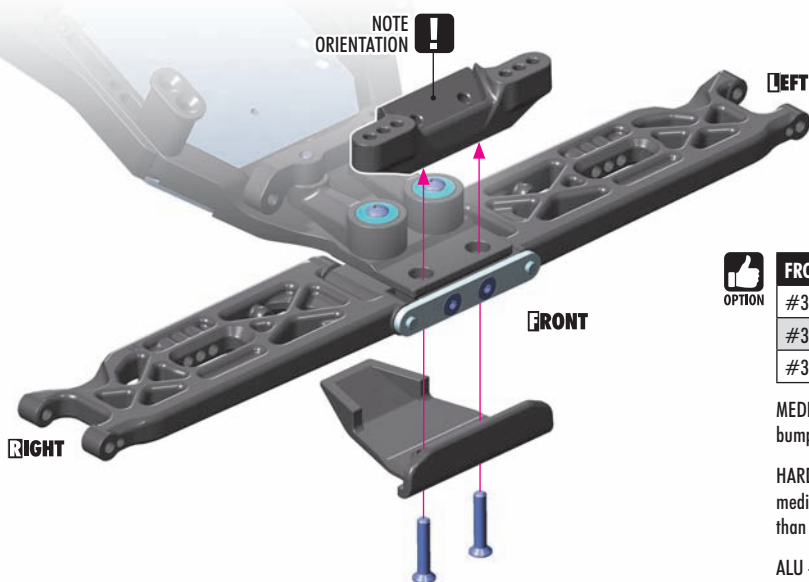

902308
SH M3x8

2x
L=R

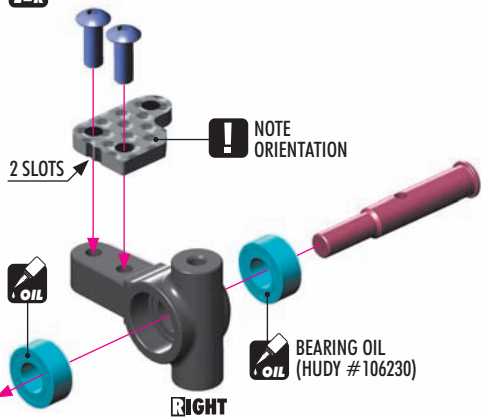

STEERING BLOCK EXTENSION

OPTION	Part #	Material	Status
	#322290	2-SLOTS	INCLUDED
	#322291	1-SLOT	OPTION
	#322292	0-SLOTS	OPTION

2 SLOTS - Turns outside wheels less, easier to drive, less aggressive.

1 SLOT - Between 2 and 0.

0 SLOTS - Most aggressive steering, suggested for very technical small tracks.



STEERING BLOCK

OPTION	Part #	Material	Status
	#322250-M	MEDIUM	INCLUDED
	#322250-H	HARD	OPTION

MEDIUM - More steering, more aggressive.

HARD - Easy to drive, less steering on-power.

5. FRONT SUSPENSION



902205
SH M2x5

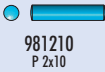

981210
P 2x10

2x L=R

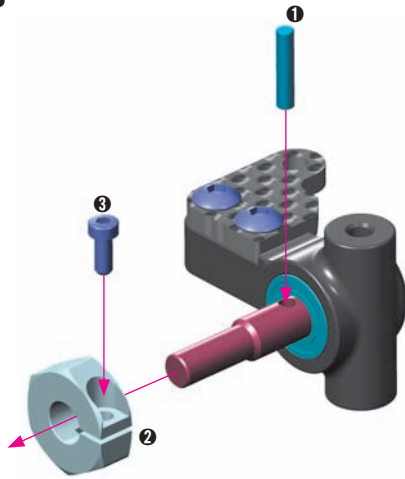

WHEEL HUBS 12MM		
#365359	+3.75mm - 5 slots	OPTION
#365358	+3.0mm - 4 slots	OPTION
#365357	+2.25mm - 3 slots	OPTION
#365356	+1.5mm - 2 slots	INCLUDED
#365355	+0.75mm - 1 slot	OPTION
#365353	0mm - 0 slots	OPTION
#365354	-0.75mm - Lightw.	OPTION

OPTIONAL HEX HUB EFFECTS
Different off-set hex hubs are used to increase or decrease the track-width.

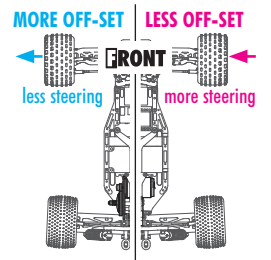

902312
SH M3x12

2x L=R

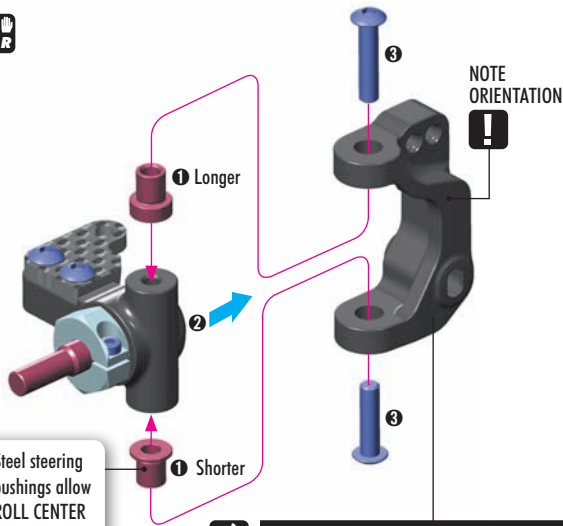

Steel steering bushings allow ROLL CENTER adjustment.



C-HUB		
#322210-M	RIGHT - MEDIUM	OPTION
#322210-H	RIGHT - HARD	INCLUDED
#322220-M	LEFT - MEDIUM	OPTION
#322220-H	LEFT - HARD	INCLUDED

MEDIUM - For very-low, low & medium traction. Absorbs bumps better, easy to drive.
HARD - For high & very-high traction. More steering, more aggressive.



LOWER ROLL CENTER (INITIAL SETTING)
TOP = LONGER bushing
BOTTOM = SHORTER bushing
Recommended for rough tracks to improve stability.

HIGHER ROLL CENTER
TOP = SHORTER bushing
BOTTOM = LONGER bushing
Recommended for smooth tracks to gain more steering.



306219
SHIM 3x6x1



902254
SH M2.5x4

2x L=R

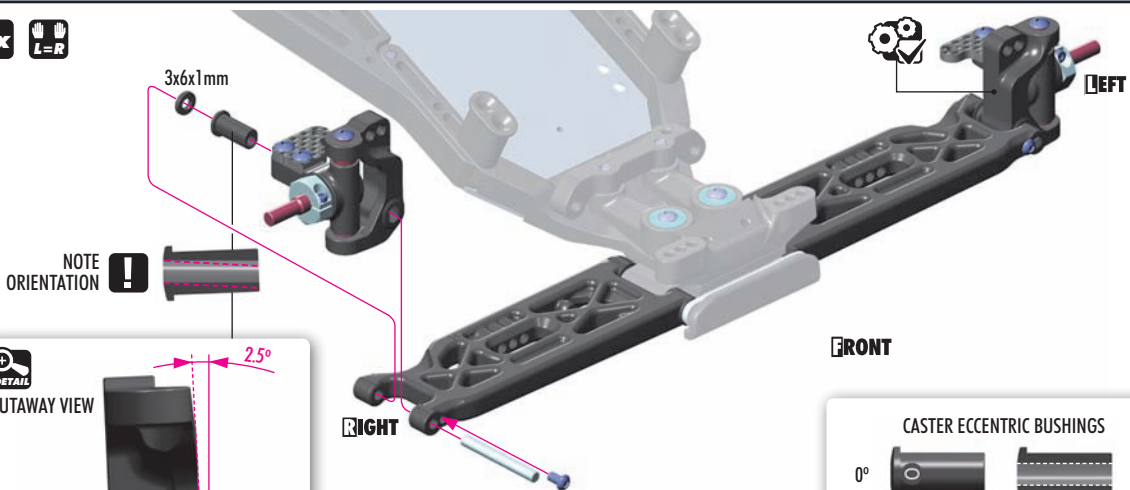

NOTE ORIENTATION

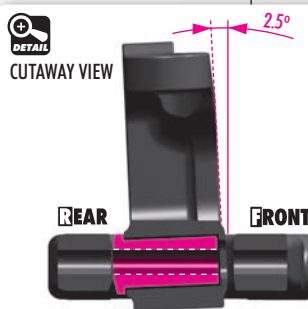

LESS CASTER = increased steering off-power
MORE CASTER = less steering off-power

FRONT

CASTER ECCENTRIC BUSHINGS

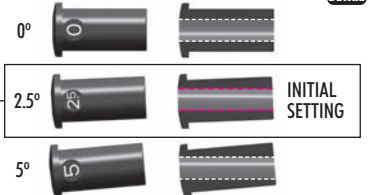

5. FRONT SUSPENSION

ROLL CENTER LINKS

2x 

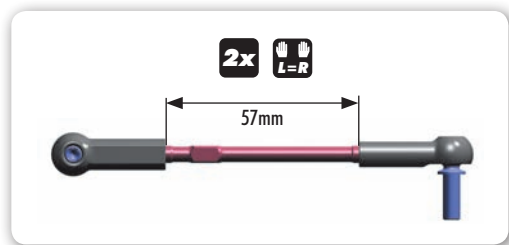
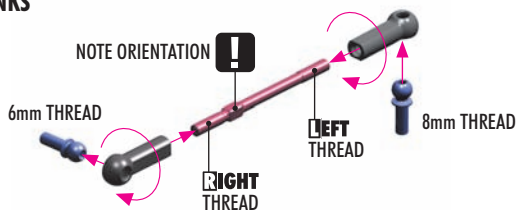

362280
CON. SHIM 3x6x2

ROLL CENTER LINKS

2x 

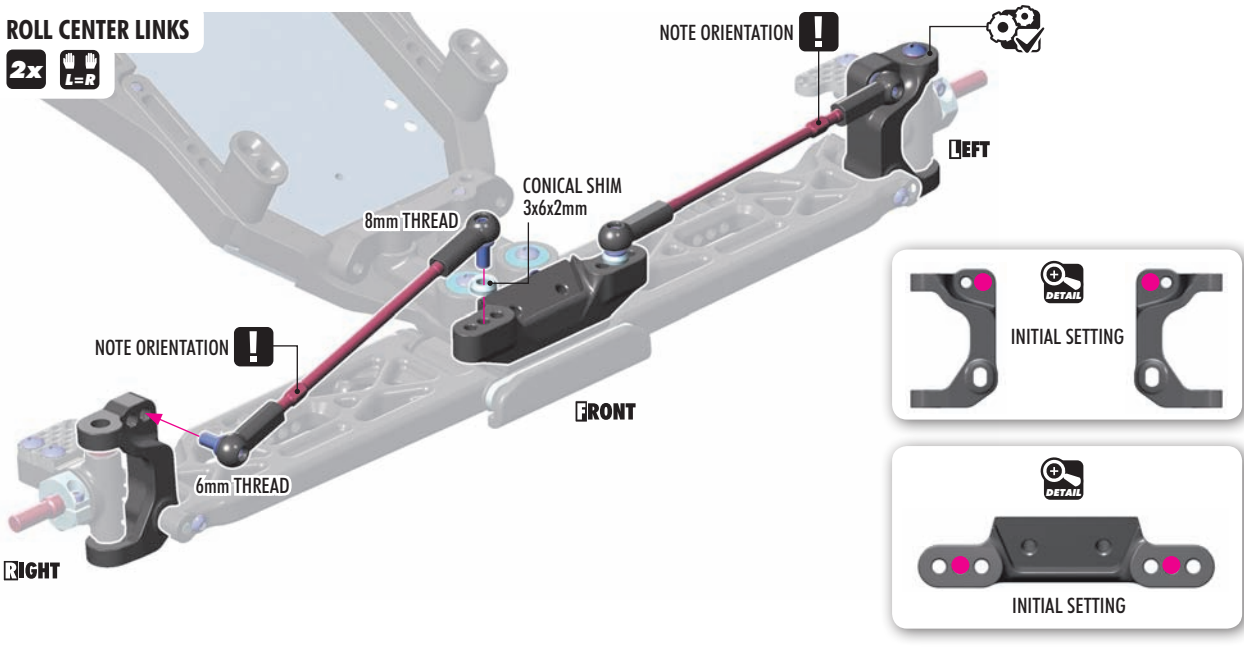

STEERING LINKS

2x 

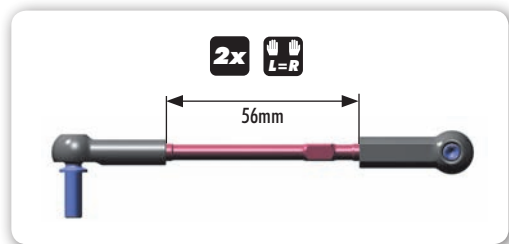
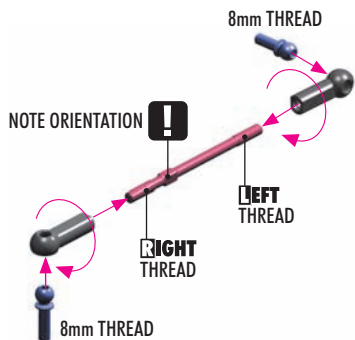

362280
CON. SHIM 3x6x2



960030
NUT M3

STEERING LINKS

2x 

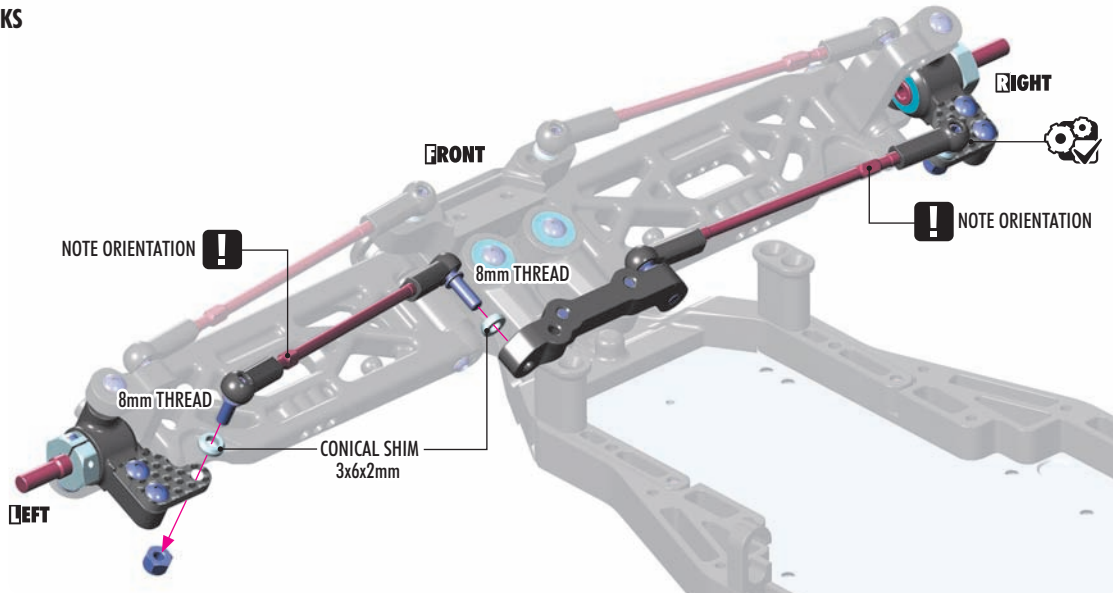

6. SHOCK ABSORBERS

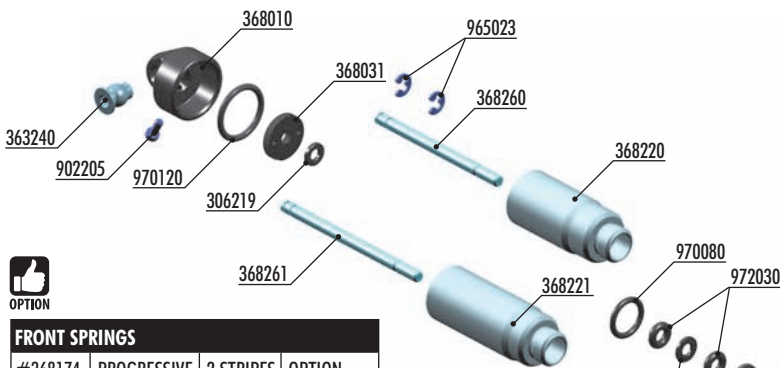

FRONT SPRINGS			
#368174	PROGRESSIVE	2 STRIPES	OPTION
#368183	LINEAR	1 DOT	OPTION
#368184	LINEAR	2 DOTS	OPTION
#368185	LINEAR	3 DOTS	OPTION
#368186	LINEAR	4 DOTS	INCLUDED

REAR SPRINGS			
#368273	PROGRESSIVE	2 STRIPES	OPTION
#368284	LINEAR	1 DOT	OPTION
#368285	LINEAR	2 DOTS	OPTION
#368286	LINEAR	3 DOTS	INCLUDED
#368287	LINEAR	4 DOTS	OPTION



SHOCK PARTS		
#368051	ALU SHOCK CAP-NUT WITH VENT HOLE (2)	OPTION
#368021	ALU SHOCK SPRING RETAINING COLLAR (4)	OPTION

PISTONS DETAIL

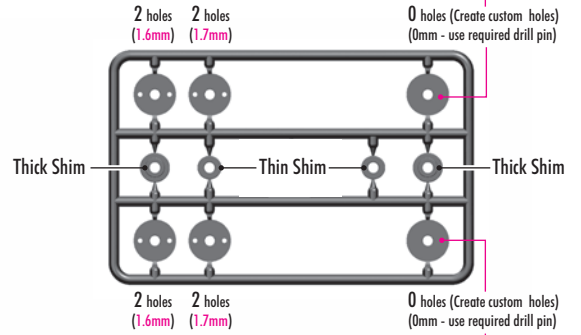

These pistons can NOT be used in shocks without making the custom holes by yourselves.



BAG



- 30 6219 COMPOSITE SET OF SERVO SHIMS (4)
- 35 2460 PIVOT BALL 5.8 - V3 (10)
- 36 3240 BALL UNIVERSAL 5.8MM WITH BACKSTOP (2)
- 36 8010 COMPOSITE SHOCK PARTS
- 36 8031 SHOCK PISTONS - COMPLETE SET - DERLIN
- 36 8040 ALU SHOCK ADJUSTABLE NUT (2)
- 36 8140 ALU LOWER SHOCK BODY CAP (2)
- 36 8174 FRONT SPRING-SET PROGRESSIVE - 2 STRIPES (2) (OPTION)
- 36 8183 FRONT SPRING-SET LINEAR - 1 DOT (2) (OPTION)
- 36 8184 FRONT SPRING-SET LINEAR - 2 DOTS (2) (OPTION)
- 36 8185 FRONT SPRING-SET LINEAR - 3 DOTS (2) (OPTION)
- 36 8186 FRONT SPRING-SET - 4 DOTS (2)
- 36 8200 REAR SHOCK ABSORBERS COMPLETE SET (2)
- 36 8220 ALU SHOCK BODY - HARD COATED (2)
- 36 8221 XT2 ALU REAR SHOCK BODY - HARD COATED (2)

- 36 8260 HARDENED SHOCK SHAFT (2)
- 36 8261 XT2 REAR HARDENED SHOCK SHAFT (2)
- 36 8273 REAR SPRING-SET PROGRESSIVE - 2 STRIPES (2) (OPTION)
- 36 8284 REAR SPRING-SET LINEAR - 1 DOT (2) (OPTION)
- 36 8285 REAR SPRING-SET LINEAR - 2 DOTS (2) (OPTION)
- 36 8286 REAR SPRING-SET LINEAR - 3 DOTS (2)
- 36 8287 REAR SPRING-SET LINEAR - 4 DOTS (2) (OPTION)

- 90 2205 HEX SCREW SH M2x5 (10)
- 96 5023 E-CLIP 2.3 (10)
- 97 0080 O-RING 8x1 (10)
- 97 0120 O-RING 12 x 1.0 (10)
- 97 0140 O-RING 14 x 1.5 (10)
- 97 2030 SILICONE O-RING 3x2 (10)



965023
C 2.3



972030
O 3x2



970080
O 8x1

SET-UP BOOK

SHOCK DAMPING
SHOCK PISTONS

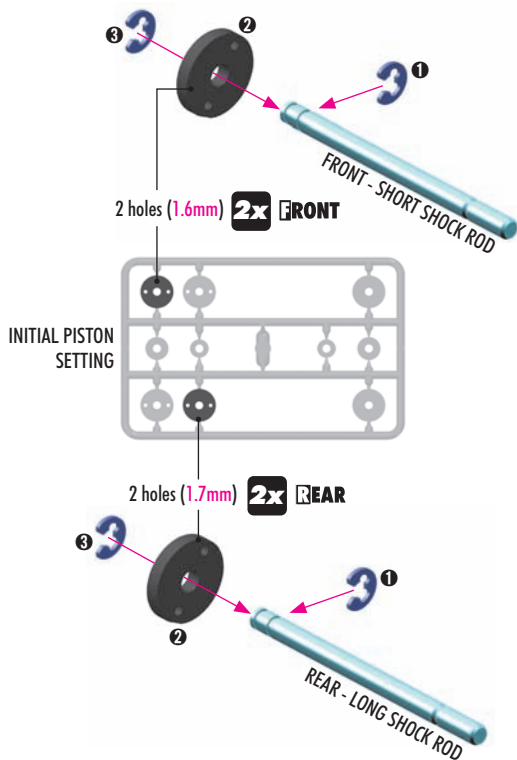

4x

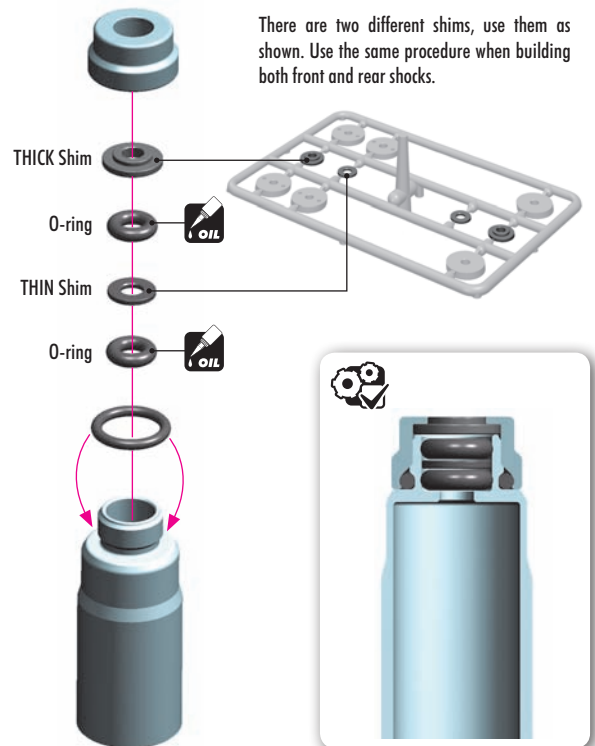

6. SHOCK ABSORBERS

10
306219
SHIM 3x6x1

Downstop shim. THICKER shim used, GREATER downstop is achieved.

! IMPORTANT
Always use same shim thickness on right and left side to achieve same downstop.

INITIAL SETTING
1mm 2mm 3mm

2x FRONT SHOCKS
SHORT SHOCK ROD
SHORT SHOCK BODY
1 3x6x1mm

2x REAR SHOCKS
LONG SHOCK ROD
LONG SHOCK BODY
1 3x6x1mm

! EXTREMELY IMPORTANT

INCORRECT
Do not push the shock rod straight through the lower shock body assembly; O-ring damage may result.

CORRECT
Twist the shock rod through the lower shock body assembly.

10
970140
O 14x1.5

4x

OIL

DETAIL

4x

970120
O 12x1

10
306219
SHIM 3x6x2

10
306219
SHIM 3x6x3

UPSTOP SHIM

2x FRONT (3x6x2mm + 3x6x3mm)
2x REAR 3x6x3mm

INCORRECT

INCORRECT

CORRECT

Grip the shock rod at top of exposed threads with side cutting pliers. Be careful not to damage the shock rod.

1~1.5mm

DETAIL

902205
SH M2x5

INITIAL SHOCK REBOUND SETTING 0% (LOW REBOUND)

Follow the steps below to set the shock rebound to the default setting of 0%.

- 2x FRONT (SHORT)**
Oil 600cSt
- 2x REAR (LONG)**
Oil 500cSt

1 Extend the shock shaft completely. Fill the shock body with the shock oil. For the FRONT shocks (short) use 600cSt oil. For the REAR shocks (long) use 500cSt oil.

2 Move the shock shaft up and down a few times to release the air bubbles trapped beneath the piston.

3 Orient the filled shock vertically for several minutes with the shock shaft fully extended. The remaining air bubbles will release.

4 Gently place the shock cap onto the filled shock body and start to tighten the cap. Tighten the cap fully.

5 Gently push the shock shaft completely into the shock body. Excess oil will flow through the hole in the shock cap.

6 Keep the shock shaft pushed in the shock body and insert the screw into the shock cap. The rebound will be at approximately 0%.

3~5x UP & DOWN

TIGHTEN FULLY

SET-UP BOOK
SHOCK OIL

6. SHOCK ABSORBERS

2x FRONT SHOCKS (SHORT)

2x REAR SHOCKS (LONG)

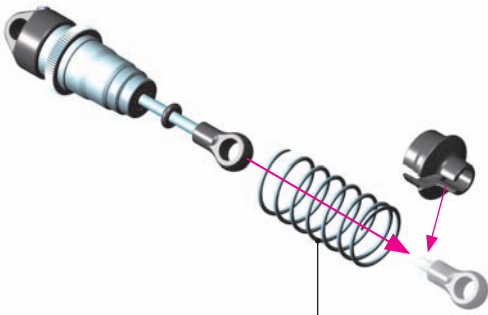

SHORT FRONT SHOCKS **2x** **2x** LONG REAR SHOCKS
Short Springs Long Springs

! IMPORTANT

Both FRONT SHOCKS must be the same overall length.
Both REAR SHOCKS must be the same overall length.

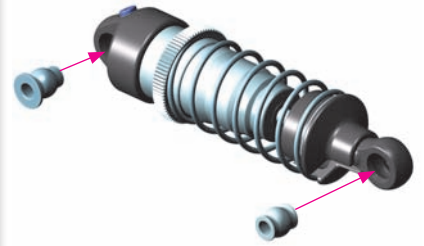
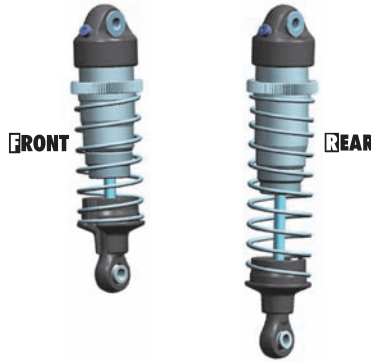

TIP ALTERNATE SHOCK REBOUND SETTING (50% AND 100%)

The default shock rebound setting is 0% (as described on page 25).
Alternatively, you may set the shock rebound setting to 50% or 100% as described below. Remove the shock springs before performing shock rebound adjustment.

SETTING THE SHOCK REBOUND TO 50% (MEDIUM REBOUND)

REMOVE SHOCK CAP AND THE SCREW FROM SHOCK CAP



1 Extend the shock shaft completely and remove the shock cap and remove screw from shock cap.



2 Fill the shock body with shock oil up to the top. Make sure to use same viscosity shock oil as is in the shock.



3 Orient the filled shock vertically for several minutes with the shock shaft fully extended. The remaining air bubbles will release.

TIGHTEN FULLY



4 Gently place the shock cap assembly onto the filled shock body.

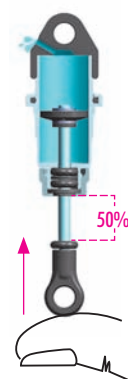

5 Push the shock shaft 50% into the shock body. Excess oil will bleed through the hole in the shock cap.

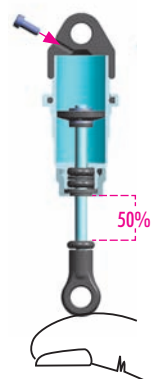

6 Keep the shock shaft pushed 50% into the shock body and insert the screw into the shock cap. The rebound will be at approximately 50%.

SETTING THE SHOCK REBOUND TO 100% (HIGH REBOUND)

REMOVE SHOCK CAP AND THE SCREW FROM SHOCK CAP



1 Extend the shock shaft completely and remove the shock cap.



2 Fill the shock body with shock oil up to the top. Make sure to use same viscosity shock oil as is in the shock.



3 Orient the filled shock vertically for several minutes with the shock shaft fully extended. The remaining air bubbles will release.

TIGHTEN FULLY



4 Gently place the shock cap assembly onto the filled shock body. Keep the shock shaft extended 100% from the shock body and tighten the shock cap completely. The rebound will be at approximately 100%.

7. FINAL ASSEMBLY



ANTI-ROLL BARS

#322472	1.2mm	OPTION
#322474	1.4mm	INCLUDED
#322476	1.6mm	OPTION
#322478	1.8mm	OPTION

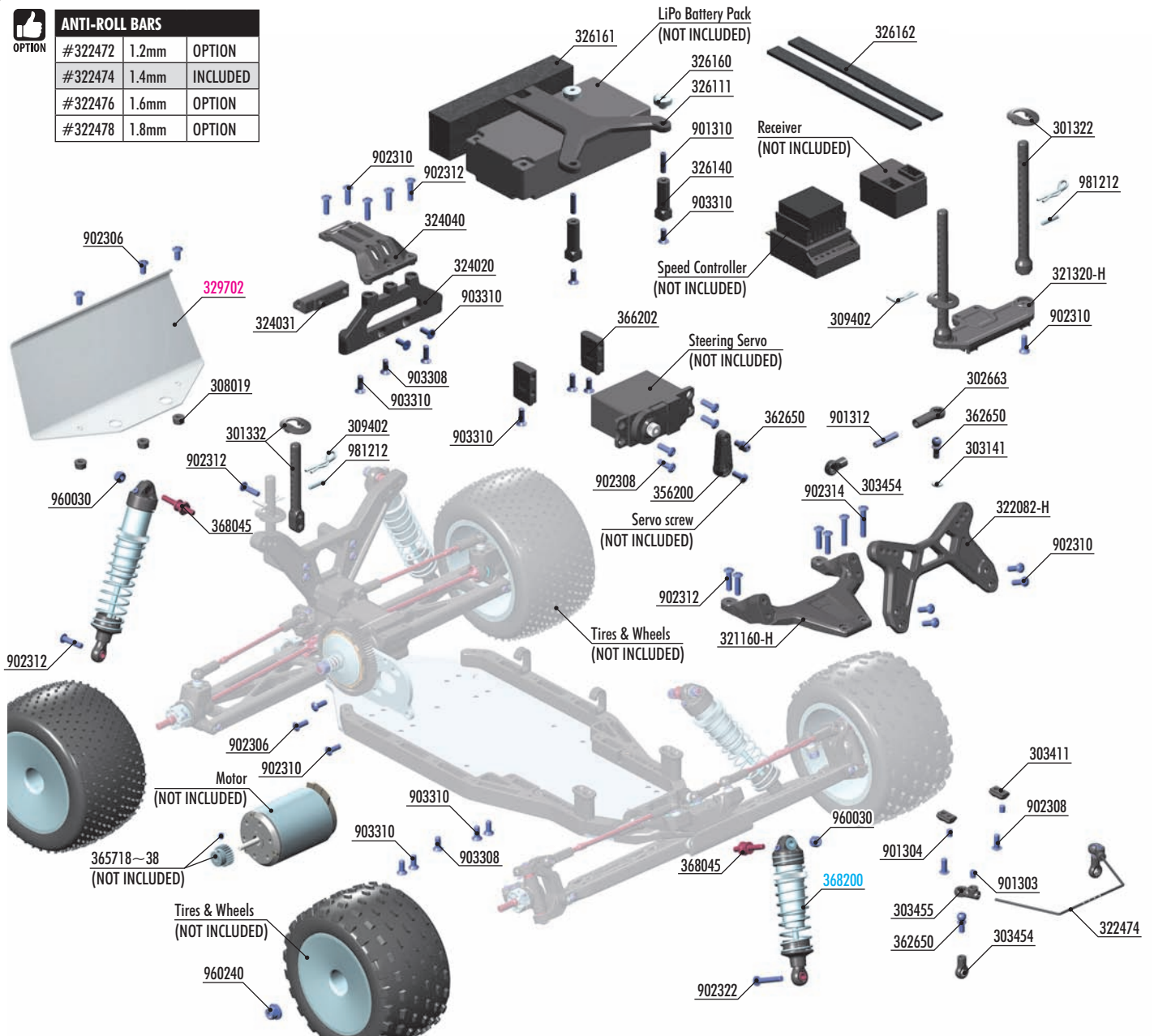

BATTERY STRAP

#326110	GRAPHITE	OPTION
#326111	COMPOSITE	INCLUDED



FRONT UPPER DECK

#321160-M	MEDIUM	OPTION
#321160-H	HARD	INCLUDED



FRONT BODY MOUNT SET

#301322	0mm	INCLUDED
#301323	+1mm	OPTION
#301324	+2mm	OPTION



REAR BODY MOUNT SET

#301332	0mm	INCLUDED
#301333	+1mm	OPTION
#301334	+2mm	OPTION

BAG

07

- 30 2663 COMPOSITE BALL JOINT 4.9MM - OPEN - V2 (8)
- 30 1322 FRONT BODY MOUNT SET 6MM
- 30 1332 REAR BODY MOUNT SET 6MM
- 30 3141 ALU SHIM 3x5x1.0MM (10)
- 30 3411 COMPOSITE ANTI-ROLL BAR HOLDERS
- 30 3454 BALL JOINT 4.9MM - OPEN (4)
- 30 3455 COMPOSITE ANTI-ROLL BAR BALL JOINT 4.9 MM (4)
- 30 8019 COMPOSITE SET OF SHOCKS SHIMS & NUTS (2)
- 30 9402 BODY CLIP FOR 6MM BODY POST (4)
- 32 1160-M COMPOSITE FRONT UPPER DECK - MEDIUM (OPTION)
- 32 1160-H COMPOSITE FRONT UPPER DECK - HARD
- 32 1320-H XT2 COMPOSITE FRONT BODY MOUNT - HARD
- 32 2082-H XT2 COMPOSITE SHOCK TOWER FRONT - HARD
- 32 2474 XT2 FRONT ANTI-ROLL BAR 1.4 MM
- 32 4020 COMPOSITE MOUNT FOR UPPER BRACE - CARPET EDITION
- 32 4031 COMPOSITE MOTOR PLATE BRACE
- 32 4040 COMPOSITE MOTOR UPPER BRACE - CARPET EDITION
- 32 6110 GRAPHITE BATTERY STRAP (OPTION)
- 32 6111 COMPOSITE BATTERY STRAP - CARPET EDITION
- 32 6140 COMPOSITE BATTERY HOLDER STAND (2)
- 32 6160 ALU BATTERY HOLDER NUT (2)
- 32 6161 FOAM SPACER FOR BATTERY
- 32 6162 SELF-ADHESIVE RUBBER 1.5x6.5x155MM (2)
- 35 6200 BRAKE/THROTTLE ARMS & STEERING SERVO ARMS - SET

- 36 2650 BALL END 4.9MM WITH THREAD 6MM (2)
- 36 5718-38 ALU PINION GEAR HARD COATED 18~38T/48 (OPTION)
- 36 6202 COMPOSITE SERVO MOUNT - HIGHER
- 36 8045 STEEL SCREW SHOCK PIVOT BALL WITH HEX (2)

- 90 1303 HEX SCREW SB M3x3 (10)
- 90 1304 HEX SCREW SB M3x4 (10)
- 90 1310 HEX SCREW SB M3x10 (10)
- 90 1312 HEX SCREW SB M3x12 (10)
- 90 2306 HEX SCREW SH M3x6 (10)
- 90 2308 HEX SCREW SH M3x8 (10)
- 90 2310 HEX SCREW SH M3x10 (10)
- 90 2312 HEX SCREW SH M3x12 (10)
- 90 2314 HEX SCREW SH M3x14 (10)
- 90 2322 HEX SCREW SH M3x22 (10)
- 90 3308 HEX SCREW SFH M3x8 (10)
- 90 3310 HEX SCREW SFH M3x10 (10)
- 96 0030 NUT M3 (10)
- 96 0240 NUT M4 WITH SERRATED FLANGE (10)
- 98 1212 PIN 2x12 (10)

36 8200 REAR SHOCK ABSORBERS COMPLETE SET (2)

32 9702 XRAY XT2 BODY

7. FINAL ASSEMBLY

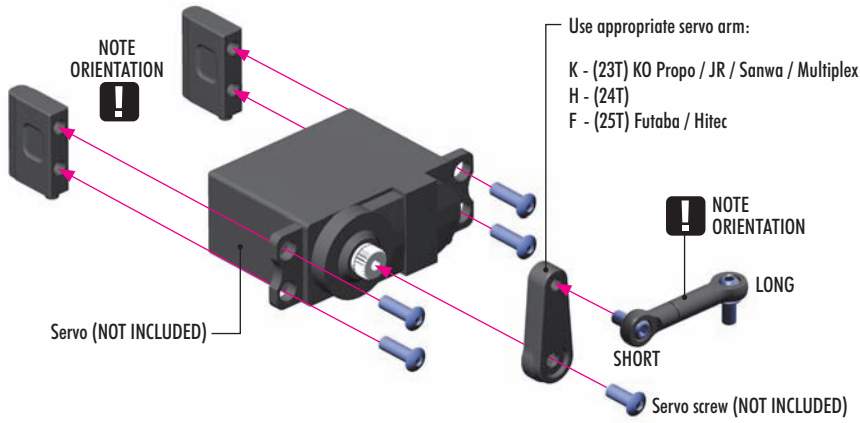
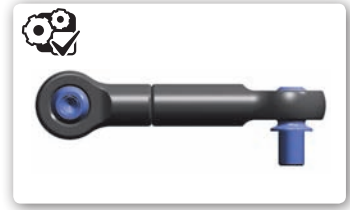
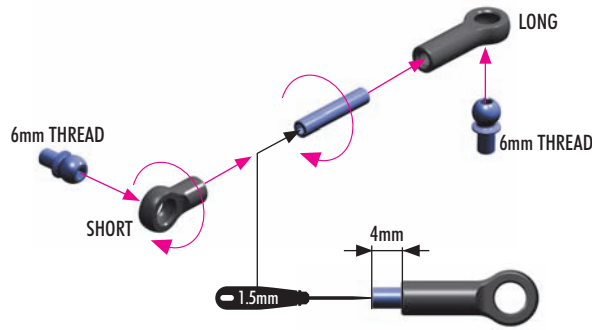

HUDY ALU SERVO HORNS

#293497	23T
#293498	24T
#293499	25T

For more in-corner steering and better steering response, aluminum servo horns may be used.

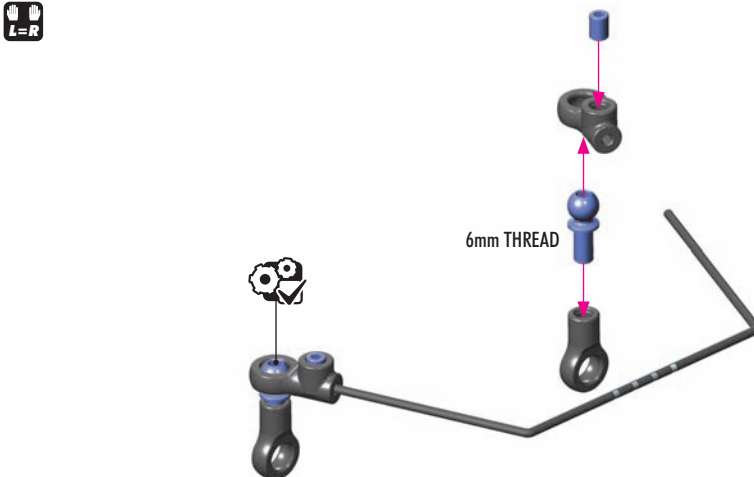
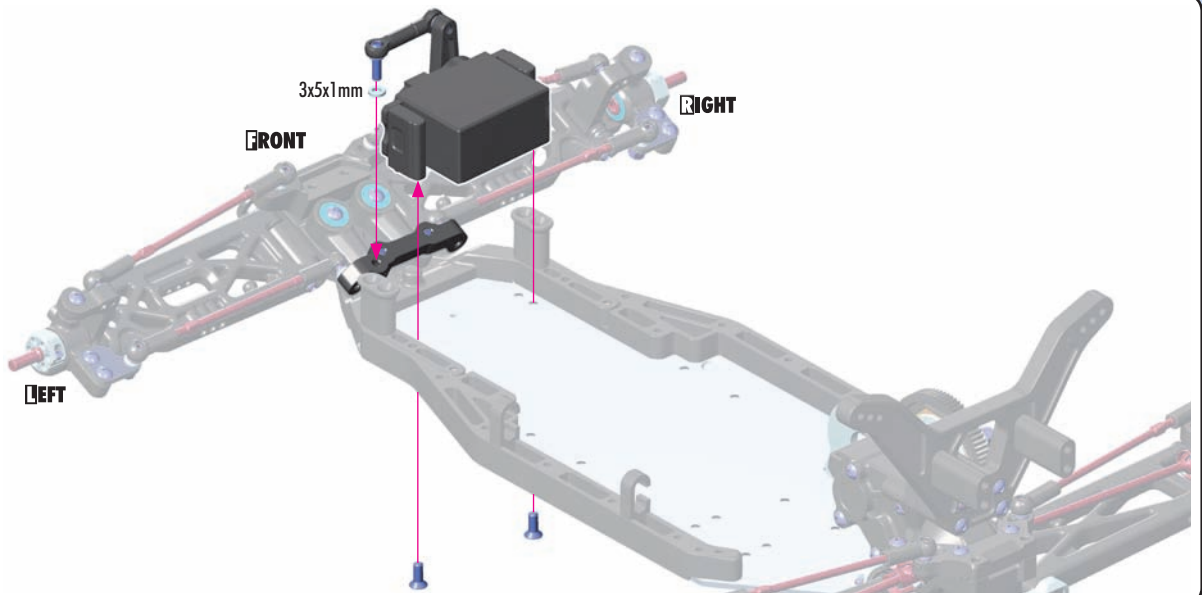

ANTI-ROLL BARS

#322472	1.2mm	OPTION
#322474	1.4mm	INCLUDED
#322476	1.6mm	OPTION
#322478	1.8mm	OPTION

7. FINAL ASSEMBLY

901304
SB M3x4

902308
SH M3x8

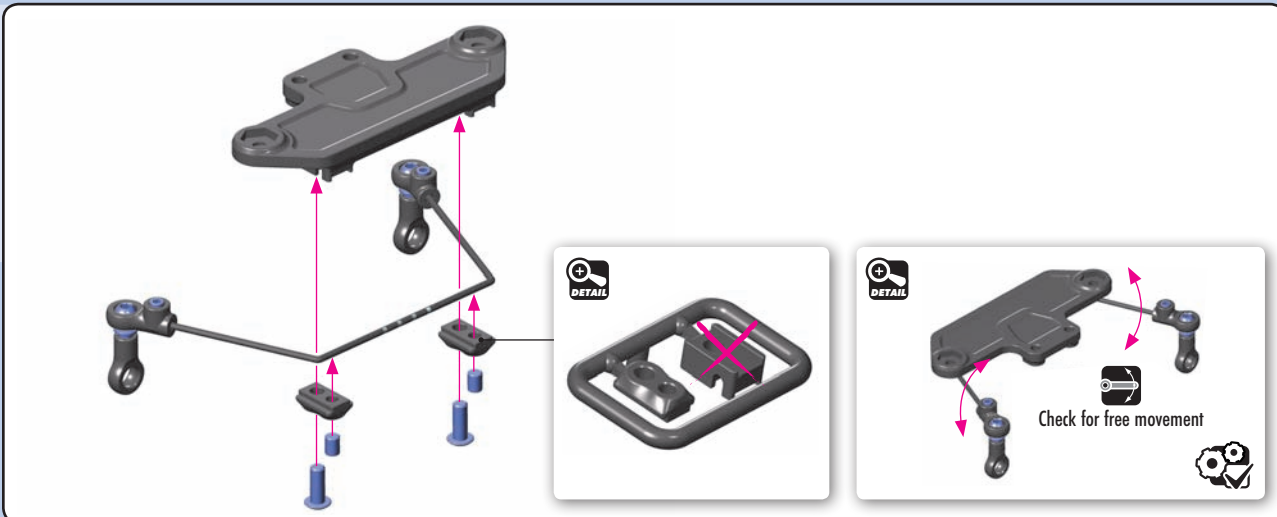

902312
SH M3x12

902314
SH M3x14



FRONT UPPER DECK

#321160-M	MEDIUM	OPTION
#321160-H	HARD	INCLUDED

MEDIUM - For very-low, low and medium traction tracks. Generates more traction, absorbs bumps better.

HARD - For high & very-high traction tracks. Makes the car more precise.

LEFT

FRONT

RIGHT

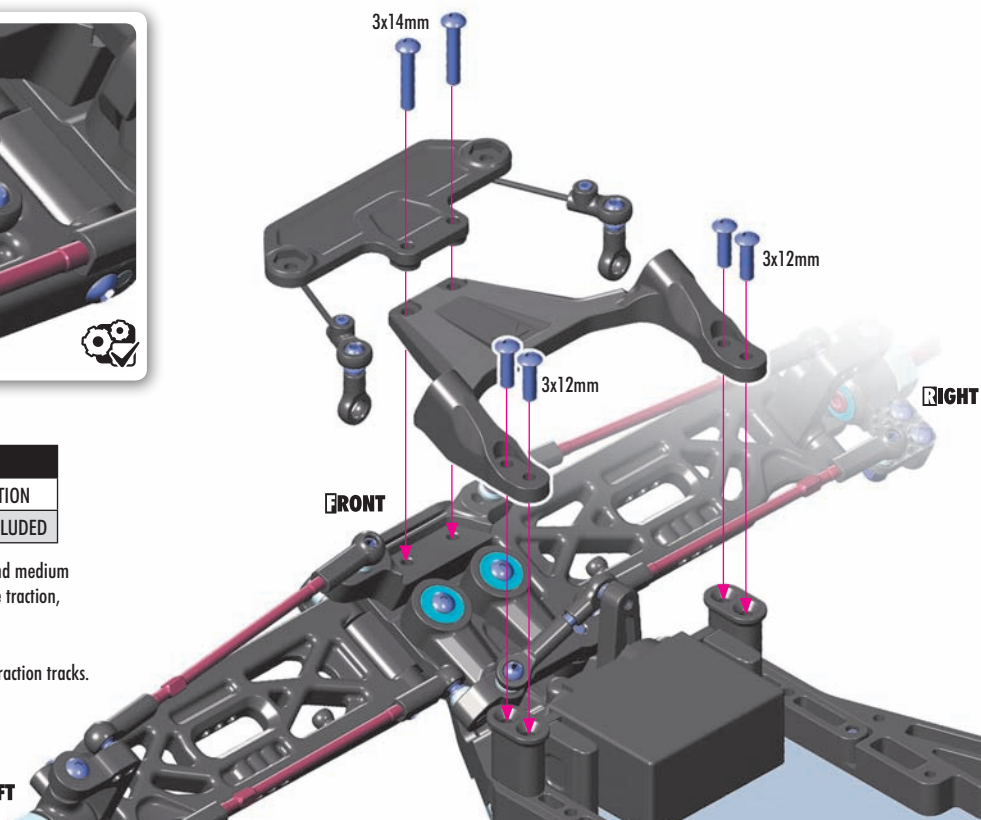

902310
SH M3x10

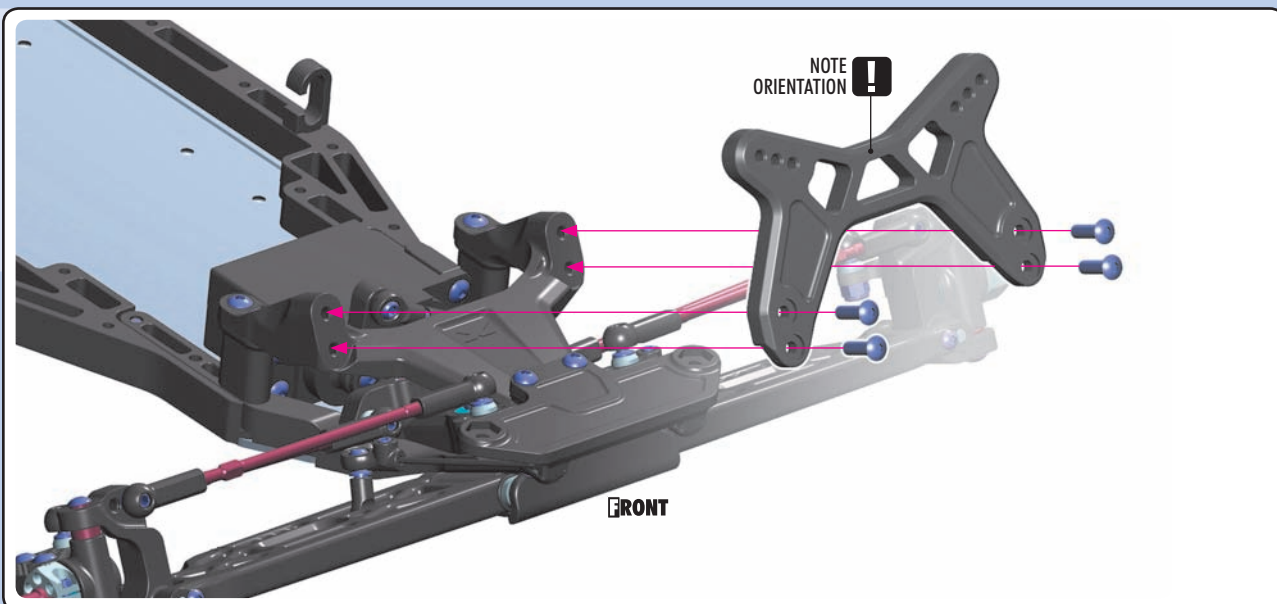

7. FINAL ASSEMBLY

2x



902322
SH M3x22



960030
NUT M3

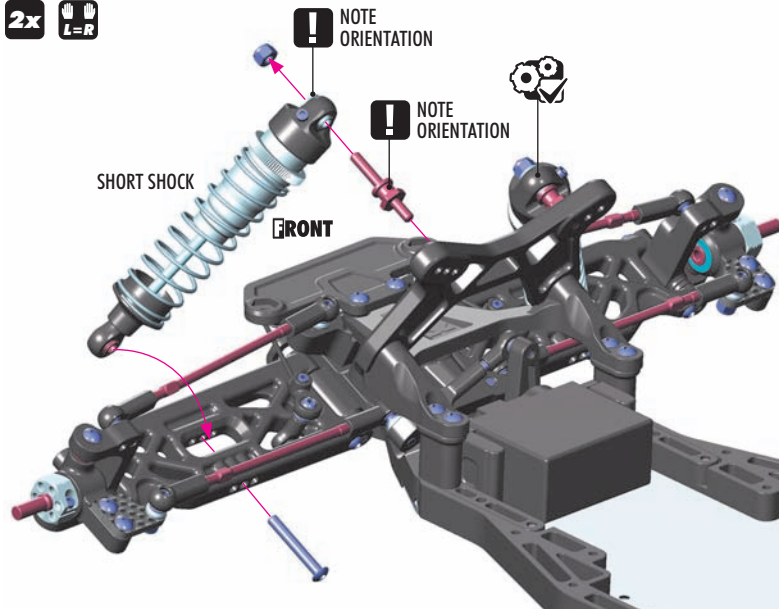

FRONT

SHORT SHOCK

NOTE ORIENTATION

NOTE ORIENTATION

DETAIL

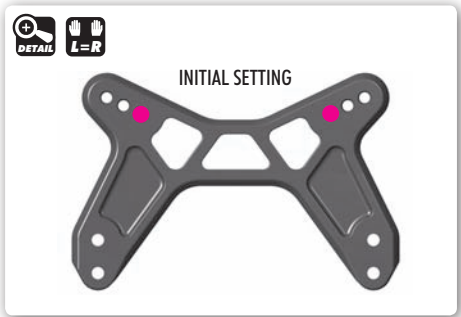

INITIAL SETTING

DETAIL



INITIAL SETTING

2x



902312
SH M3x12



960030
NUT M3

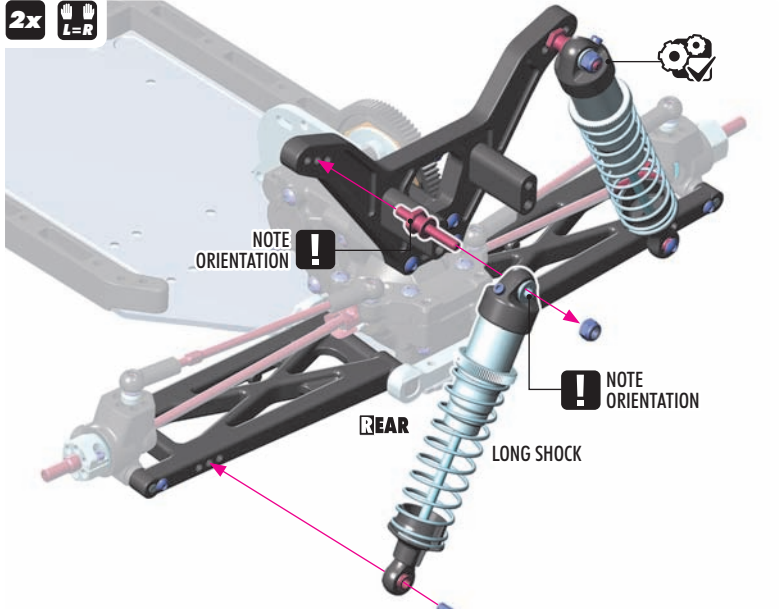

REAR

LONG SHOCK

NOTE ORIENTATION

NOTE ORIENTATION

DETAIL

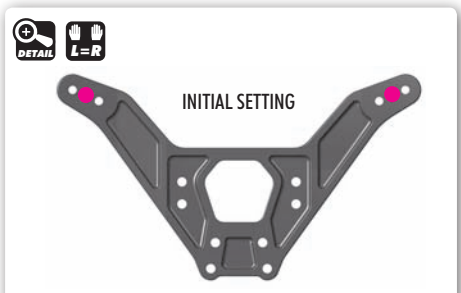

INITIAL SETTING

DETAIL



INITIAL SETTING

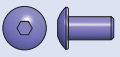

902306
SH M3x6

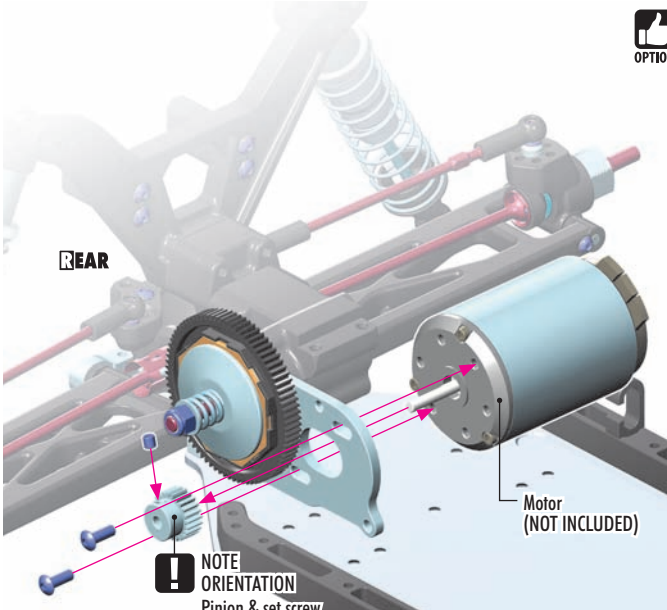

REAR

Motor (NOT INCLUDED)

NOTE ORIENTATION
Pinion & set screw (NOT INCLUDED)

XRAY PINIONS

#365718	18T / 48P
#365719	19T / 48P
#365720	20T / 48P
#365721	21T / 48P
#365722	22T / 48P
#365723	23T / 48P
#365724	24T / 48
#365725	25T / 48
#365726	26T / 48
#365727	27T / 48
#365728	28T / 48
#365729	29T / 48
#365730	30T / 48
#365731	31T / 48
#365732	32T / 48
#365733	33T / 48
#365734	34T / 48
#365735	35T / 48
#365736	36T / 48
#365737	37T / 48
#365738	38T / 48

OPTION

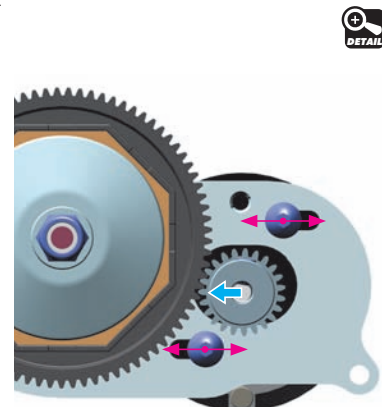

Adjust the motor so the pinion meshes with the spur gear properly. Make sure the gear mesh is not too tight.

There should be a small amount of play between the teeth of the pinion gear and the spur gear.

7. FINAL ASSEMBLY

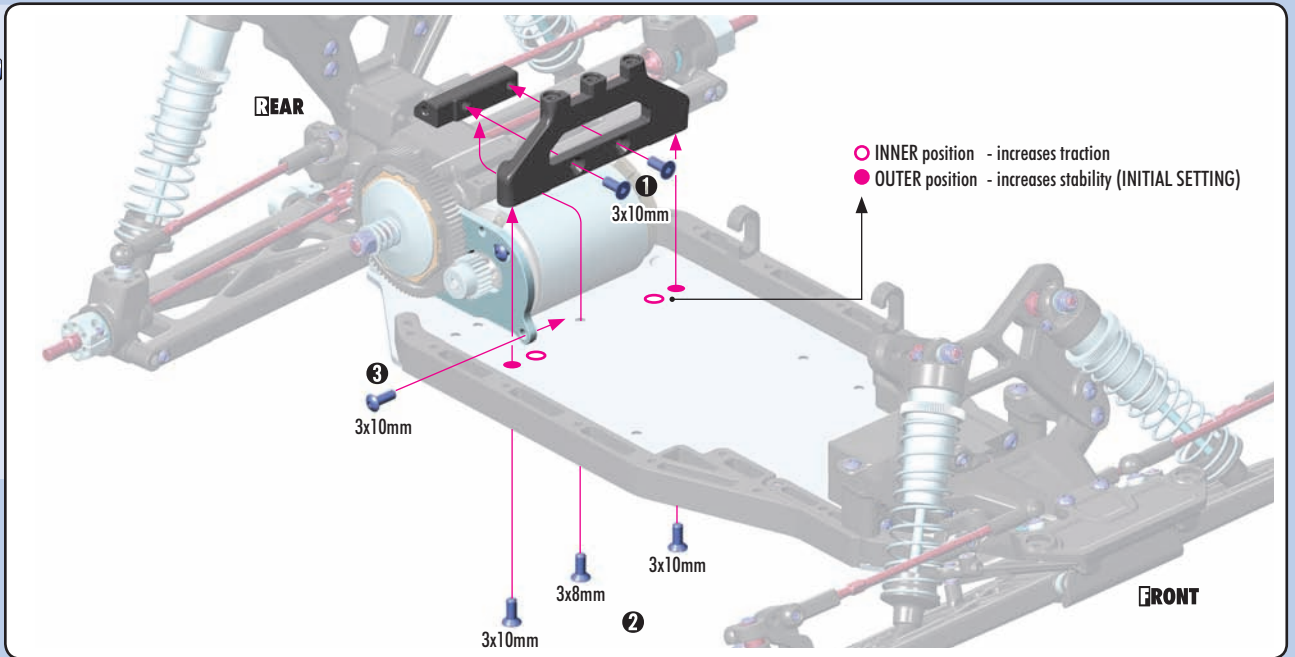

902312
SFH M3x12

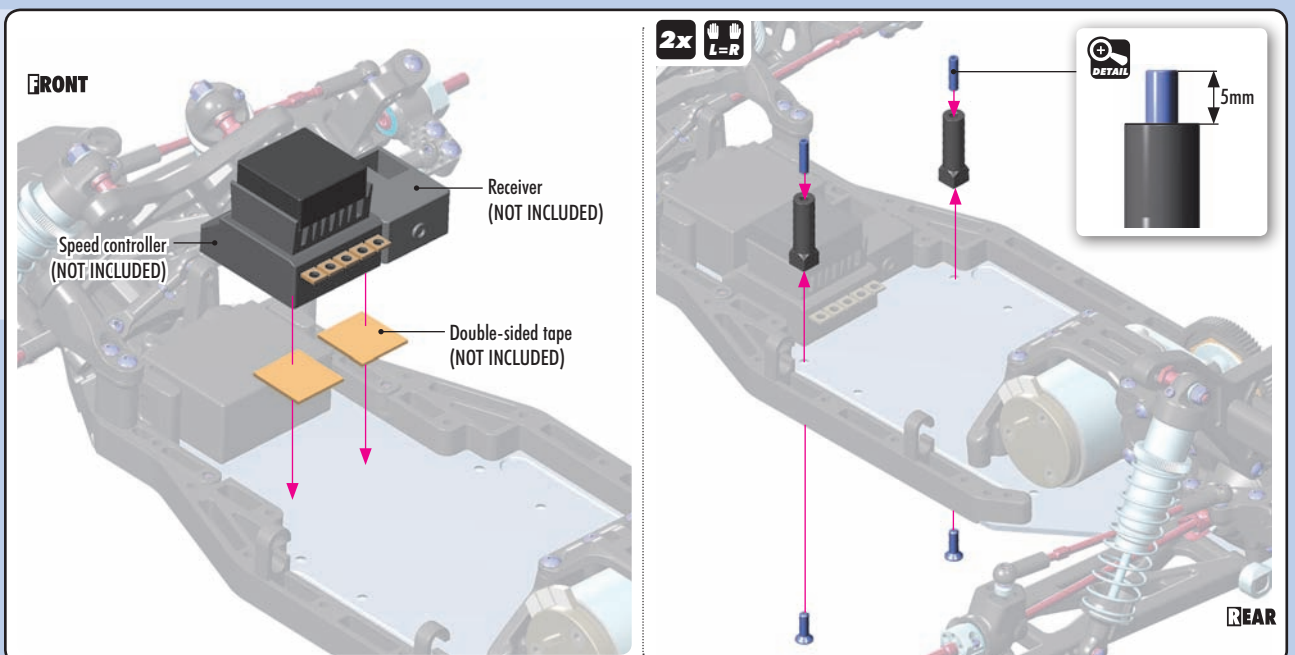
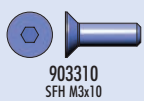
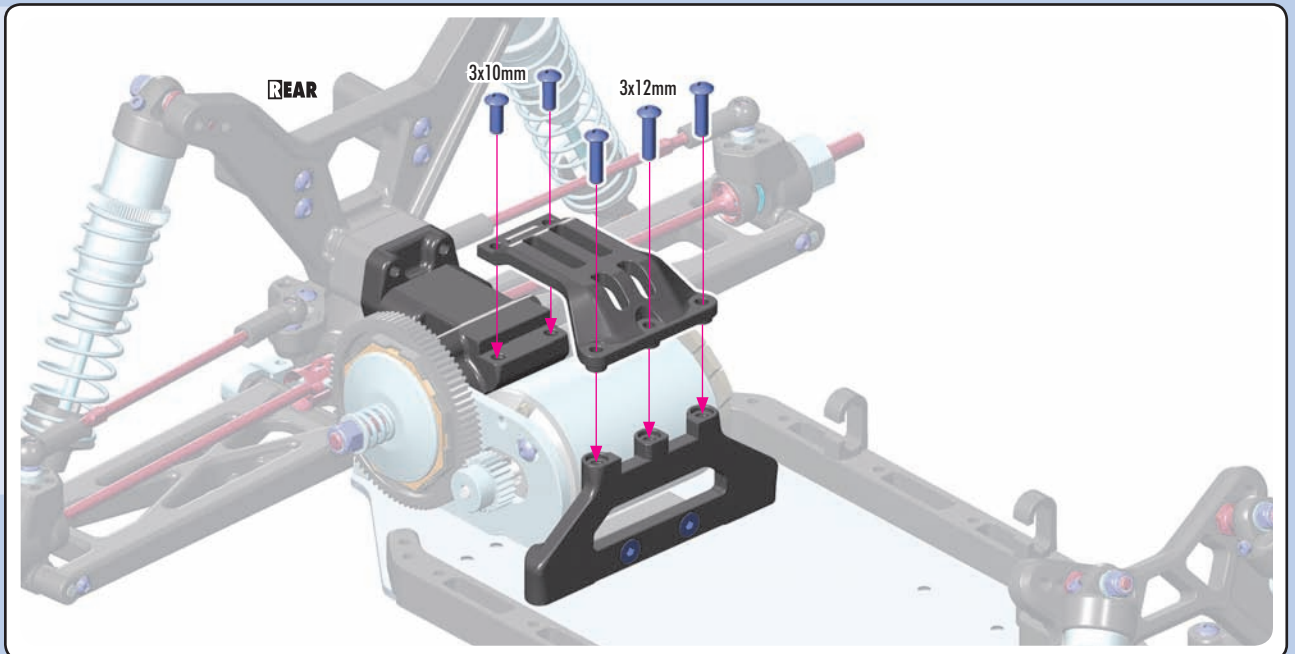

7. FINAL ASSEMBLY

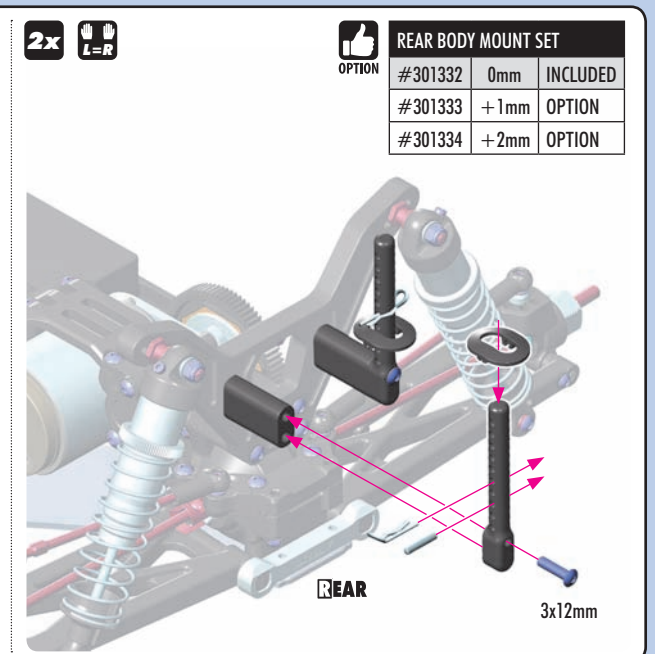
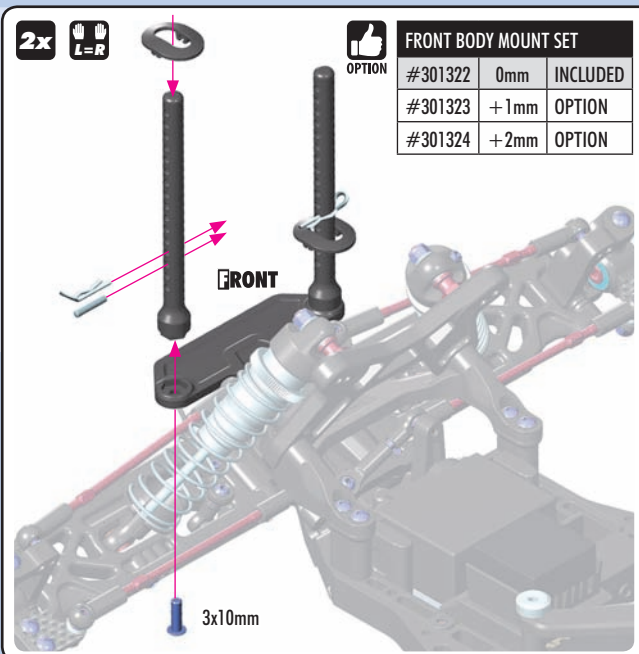
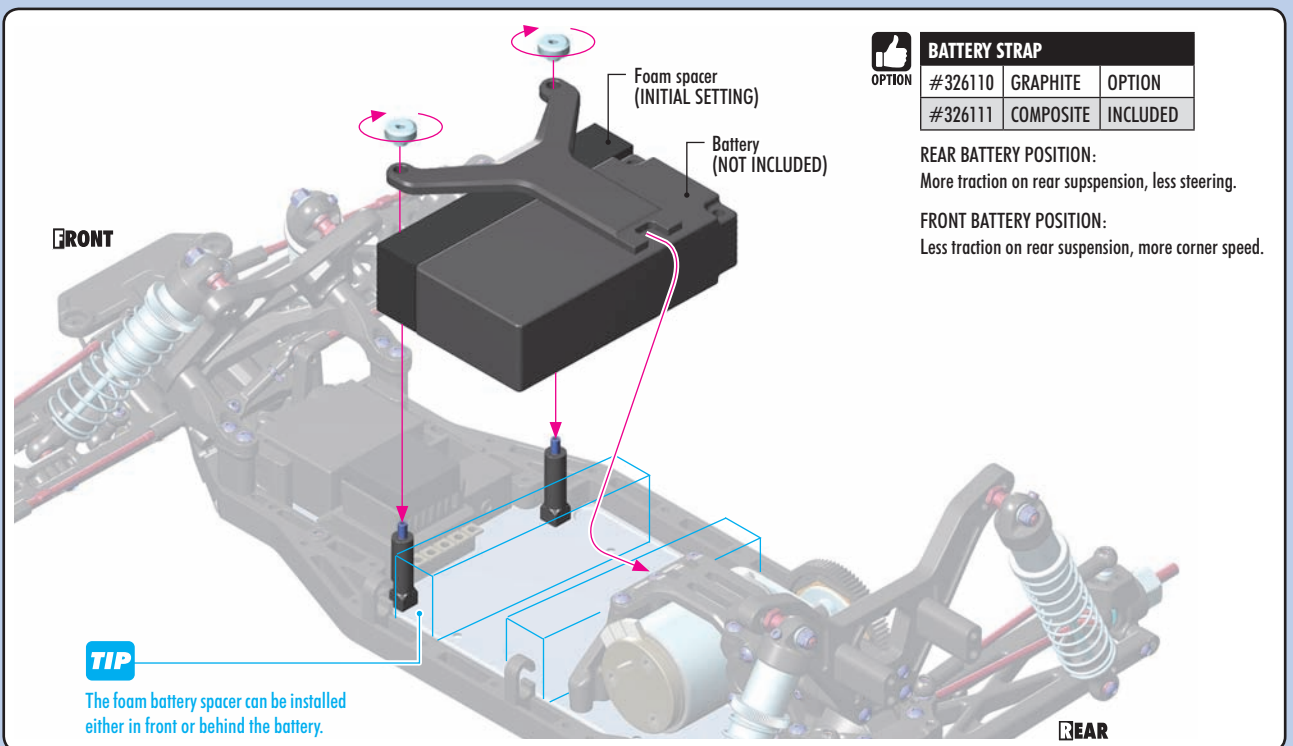
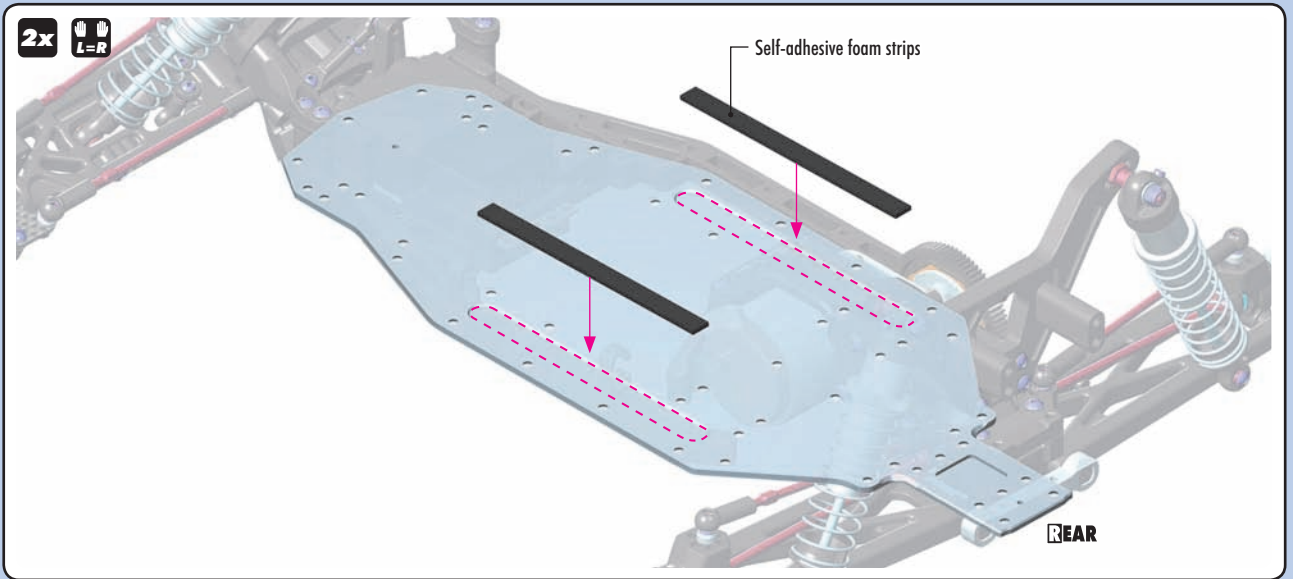

7. FINAL ASSEMBLY



960240
N M4

4x
L=R

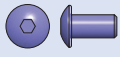
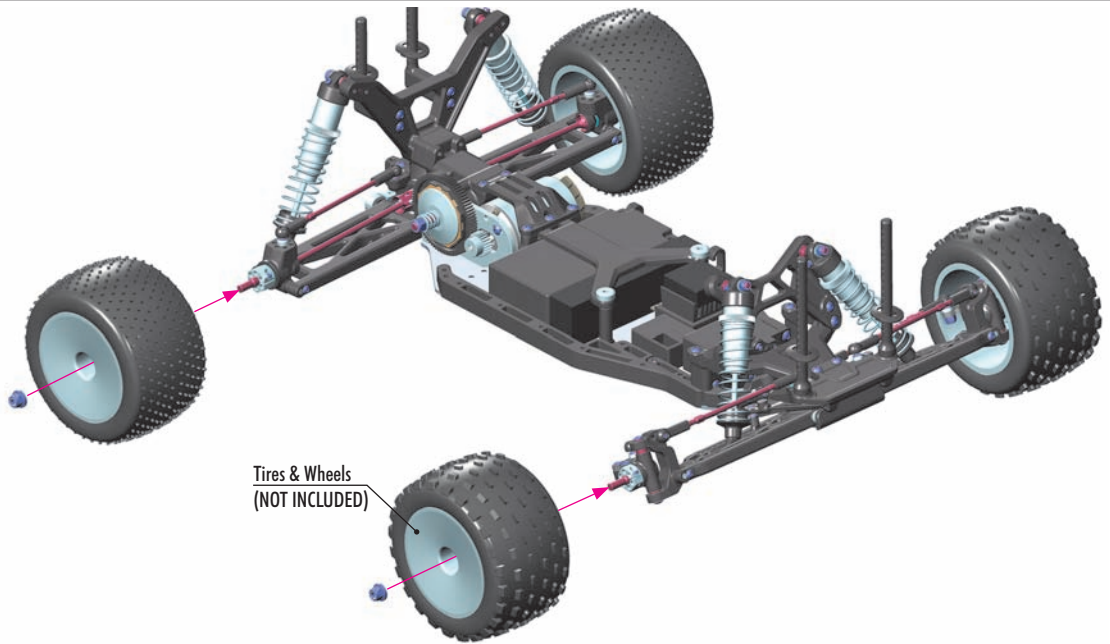

902306
SH M3x6



308019
NUT M3

- 1 Before cutting and making holes on the BODY, put the unpainted body on the chassis to confirm the mounting position and location for holes and cutouts. Before cutting and making holes on the WING, put the unpainted wing on the wing holders to confirm the mounting position and location for holes and cutouts.
- 2 Before painting, wash the inside of the body with mild detergent, and then rinse and dry thoroughly.
- 3 Mask all windows.
- 4 Apply paint masks as appropriate.

- 5 Paint the body using paints formulated for polycarbonate bodies.
- 6 When the paint is dry, remove the masking.
- 7 Carefully cut out the body using appropriate scissors or cutting tools.
- 8 When you have finished cutting, peel off the external protective films.
- 9 Assembly rear wing.

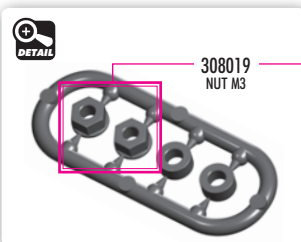
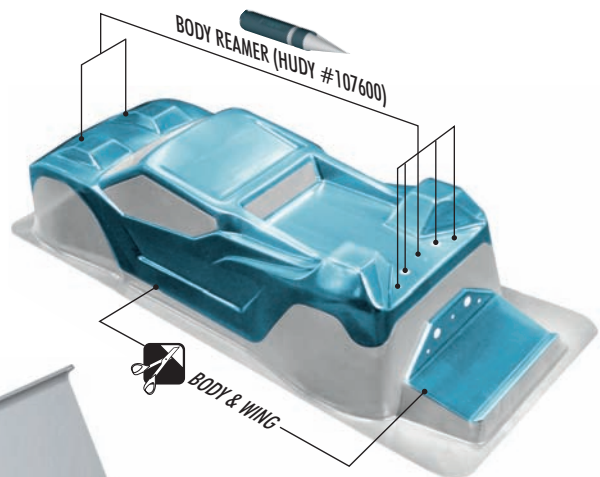
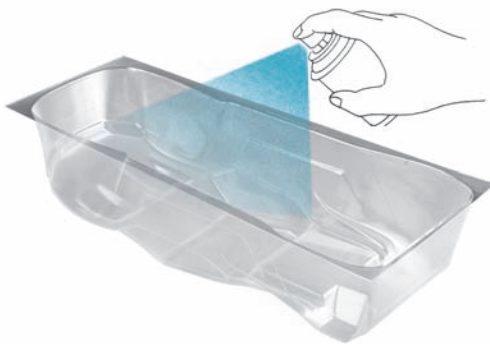

LEFT MOTOR POSITION ASSEMBLY

LEFT MOTOR POSITION ASSEMBLY



Follow these steps to change your motor position to the LEFT side.
Use the solidly-colored optional parts shown in the exploded view.

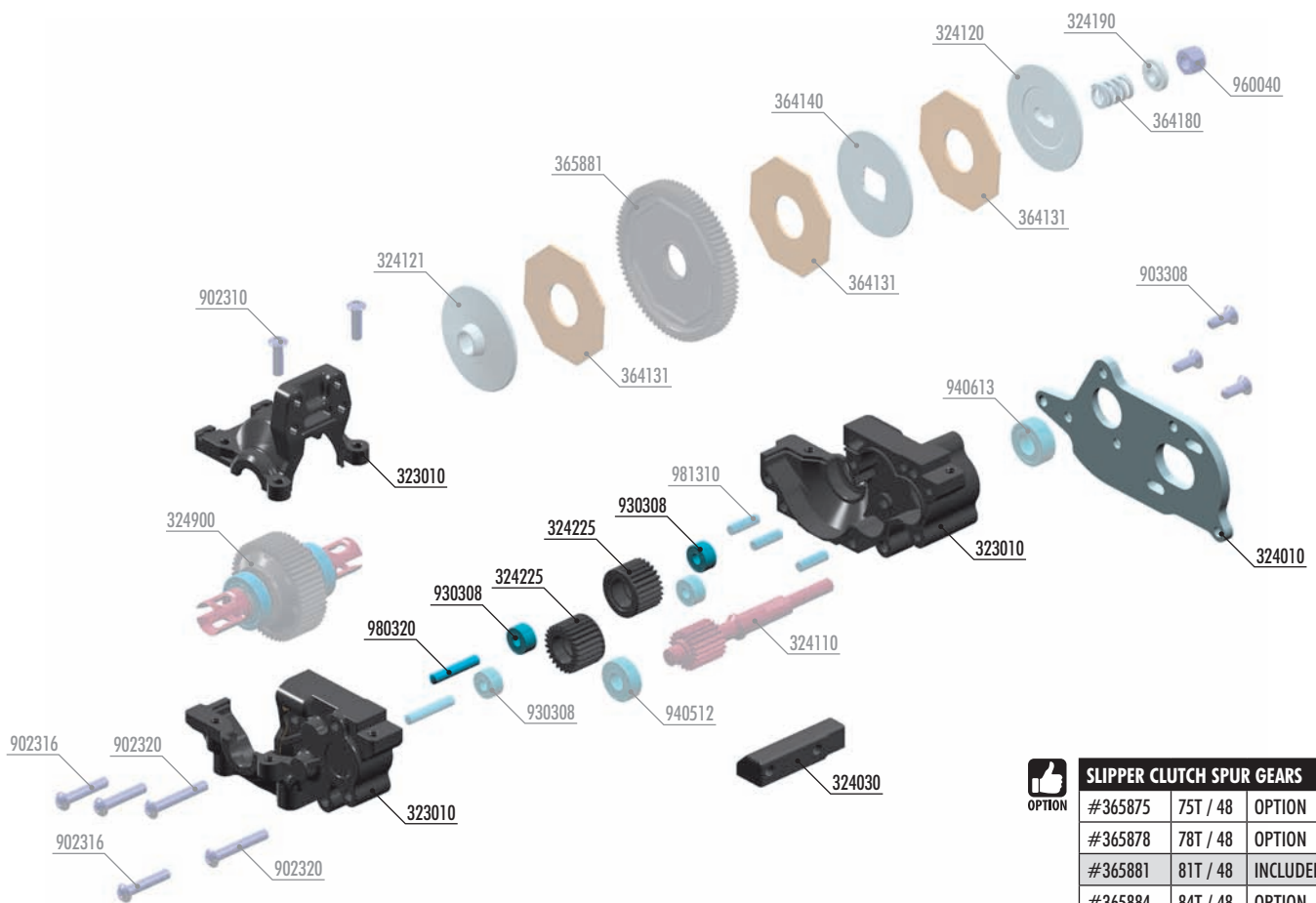
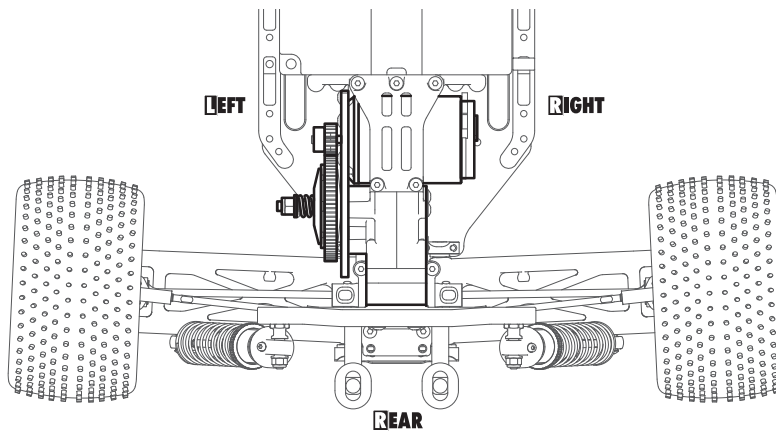

SLIPPER CLUTCH SPUR GEARS		
#365875	75T / 48	OPTION
#365878	78T / 48	OPTION
#365881	81T / 48	INCLUDED
#365884	84T / 48	OPTION
#365887	87T / 48	OPTION

- 32 3010 COMPOSITE MID GEAR BOX SET
- 32 4010 ALU MID MOTOR PLATE - SWISS 7075 T6 (3MM)
- 32 4030 COMPOSITE MOTOR PLATE BRACE
- 32 4110 ALU TOP SHAFT 20T - SWISS 7075 T6 - HARD COATED
- 32 4120 ALU 3-PAD SLIPPER CLUTCH PLATE - SWISS 7075 T6
- 32 4121 ALU 3-PAD SLIPPER CLUTCH PLATE WITH ADAPTER
- 32 4190 ALU 3-PAD SLIPPER CLUTCH SHIM
- 32 4225 COMPOSITE GEAR 25T - GRAPHITE
- 36 4131 SLIPPER CLUTCH PAD "SLS" - V2 (2)
- 36 4140 ALU 3-PAD SLIPPER CLUTCH PLATE DISC - 7075 T6
- 36 4180 SLIPPER CLUTCH SPRING C=30 - BLACK
- 36 5875 COMPOSITE 3-PAD SLIPPER CLUTCH SPUR GEAR 75T / 48 (OPTION)
- 36 5878 COMPOSITE 3-PAD SLIPPER CLUTCH SPUR GEAR 78T / 48 (OPTION)
- 36 5881 COMPOSITE 3-PAD SLIPPER CLUTCH SPUR GEAR 81T / 48
- 36 5884 COMPOSITE 3-PAD SLIPPER CLUTCH SPUR GEAR 84T / 48 (OPTION)

- 36 5887 COMPOSITE 3-PAD SLIPPER CLUTCH SPUR GEAR 87T / 48 (OPTION)
- 90 2310 HEX SCREW SH M3x10 (10)
- 90 2316 HEX SCREW SH M3x16 (10)
- 90 2320 HEX SCREW SH M3x20 (10)
- 90 3308 HEX SCREW SFH M3x8 (10)
- 93 0308 BALL-BEARING 3x8x4 (2)
- 94 0512 HIGH-SPEED BALL-BEARING 5x12x4 RUBBER SEALED (2)
- 94 0613 HIGH-SPEED BALL-BEARING 6x13x5 RUBBER SEALED (2)
- 96 0040 NUT M4 (10)
- 98 0320 PIN 3x20 (10)
- 98 1310 PIN 3x10 (10)
- 32 4900 GEAR DIFFERENTIAL - SET

LEFT MOTOR POSITION ASSEMBLY

PAGE 8 / STEP 1



981310
P 3x10



980320
P 3x20

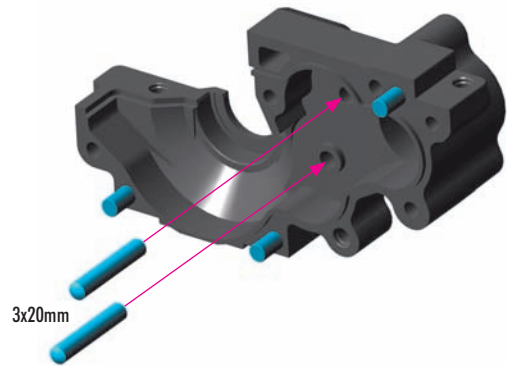
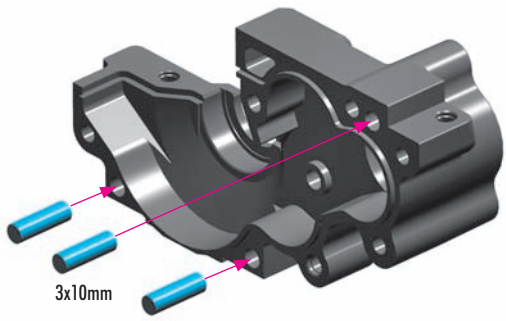

940613
BB 6x13x5

PAGE 8 / STEP 2

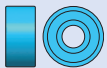
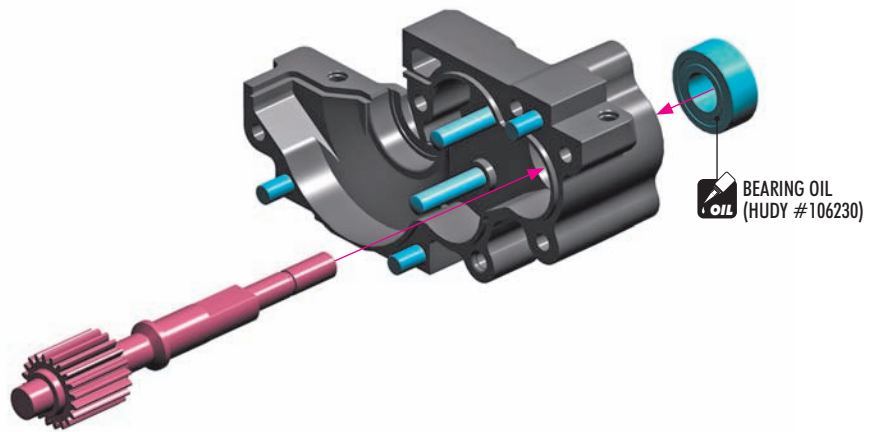

930308
BB 3x8x4

PAGE 9 / STEP 1

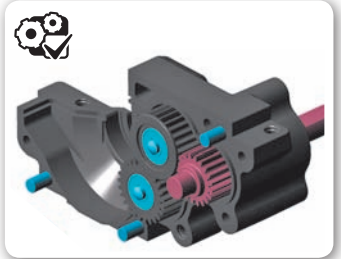
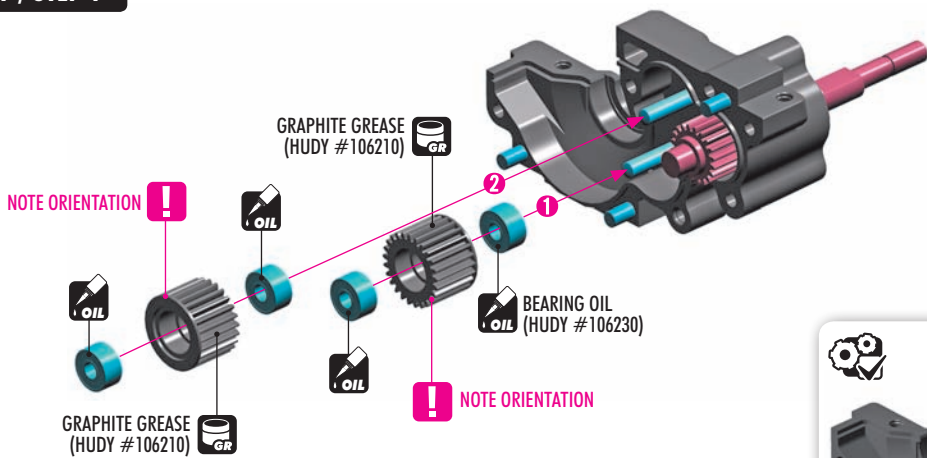

LEFT MOTOR POSITION ASSEMBLY

PAGE 9 / STEP 2

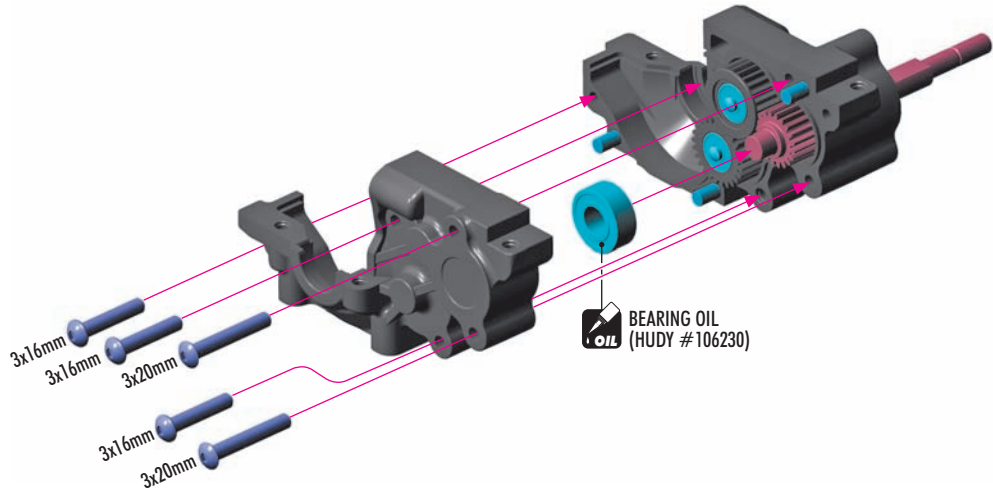
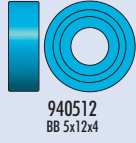
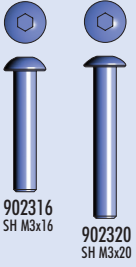

PAGE 10 / STEP 1

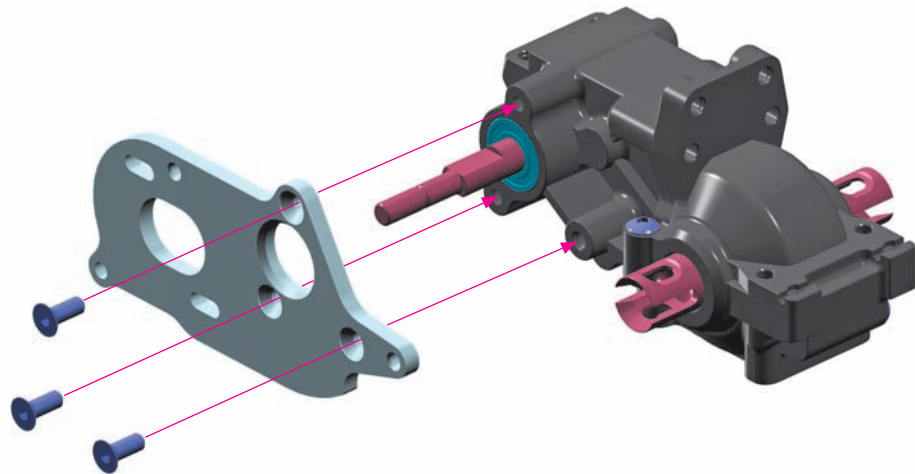

PAGE 10 / STEP 2

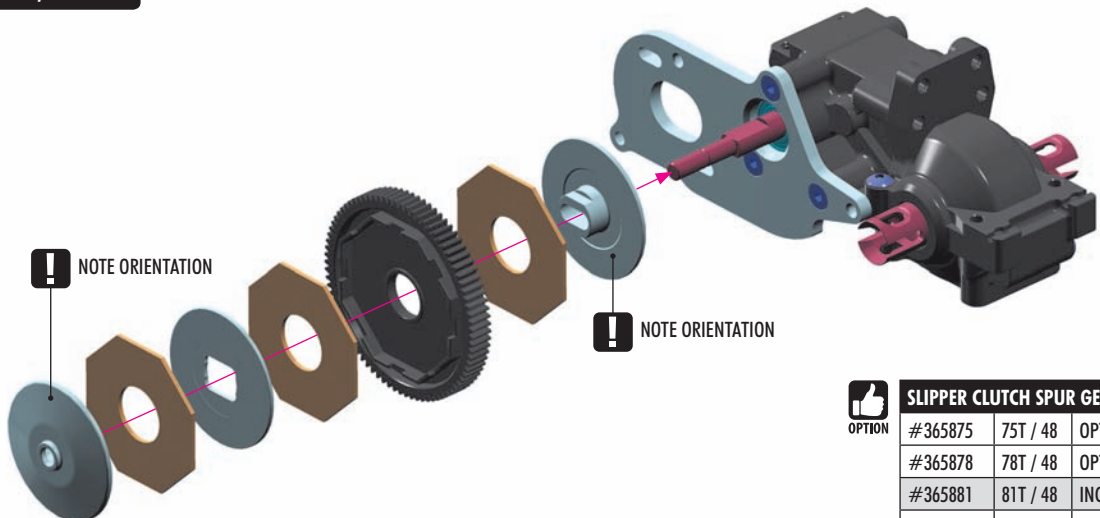

OPTION

SLIPPER CLUTCH SPUR GEARS

#365875	75T / 48	OPTION
#365878	78T / 48	OPTION
#365881	81T / 48	INCLUDED
#365884	84T / 48	OPTION
#365887	87T / 48	OPTION

LEFT MOTOR POSITION ASSEMBLY



960040
N M4

PAGE 10 / STEP 3

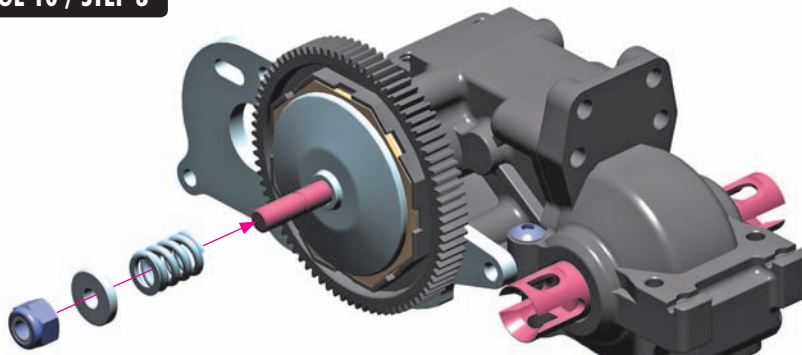

INITIAL SETTING

0.2mm

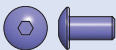
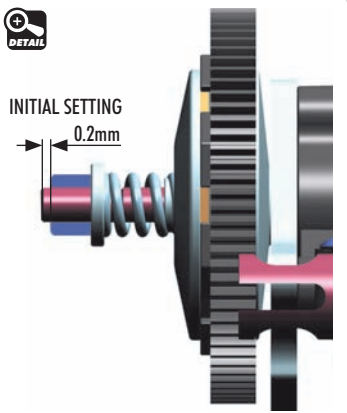

902306
SH M3x6

PAGE 30 / STEP 3

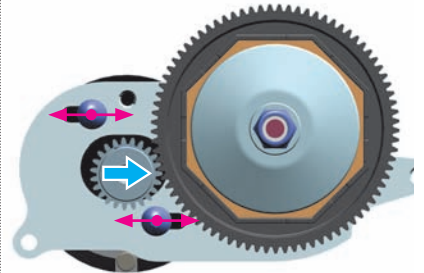
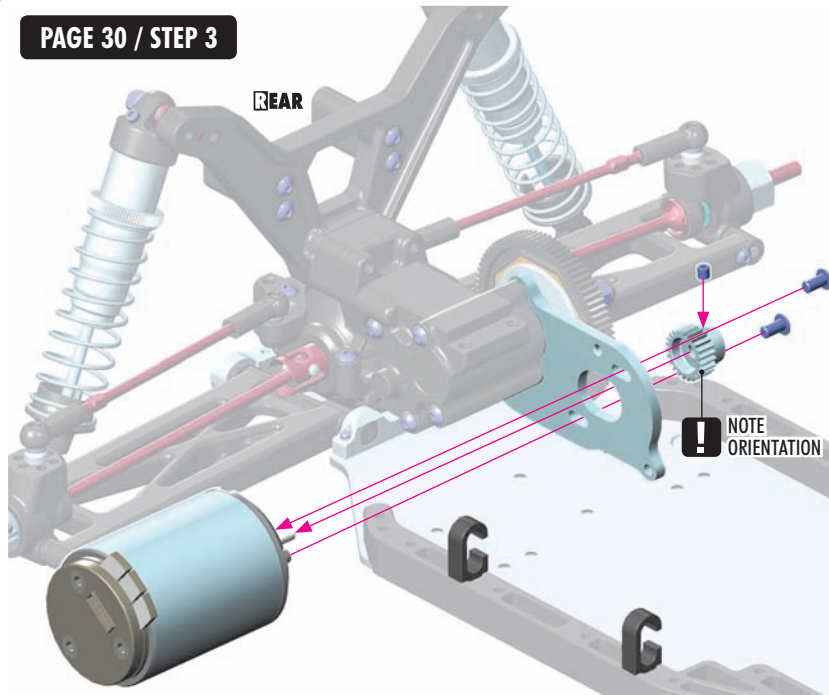

Adjust the motor so the pinion meshes with the spur gear properly. Make sure the gear mesh is not too tight.

There should be a small amount of play between the teeth of the pinion gear and the spur gear.



902310
SH M3x10



903308
SFH M3x8



903310
SFH M3x10

PAGE 31 / STEP 1

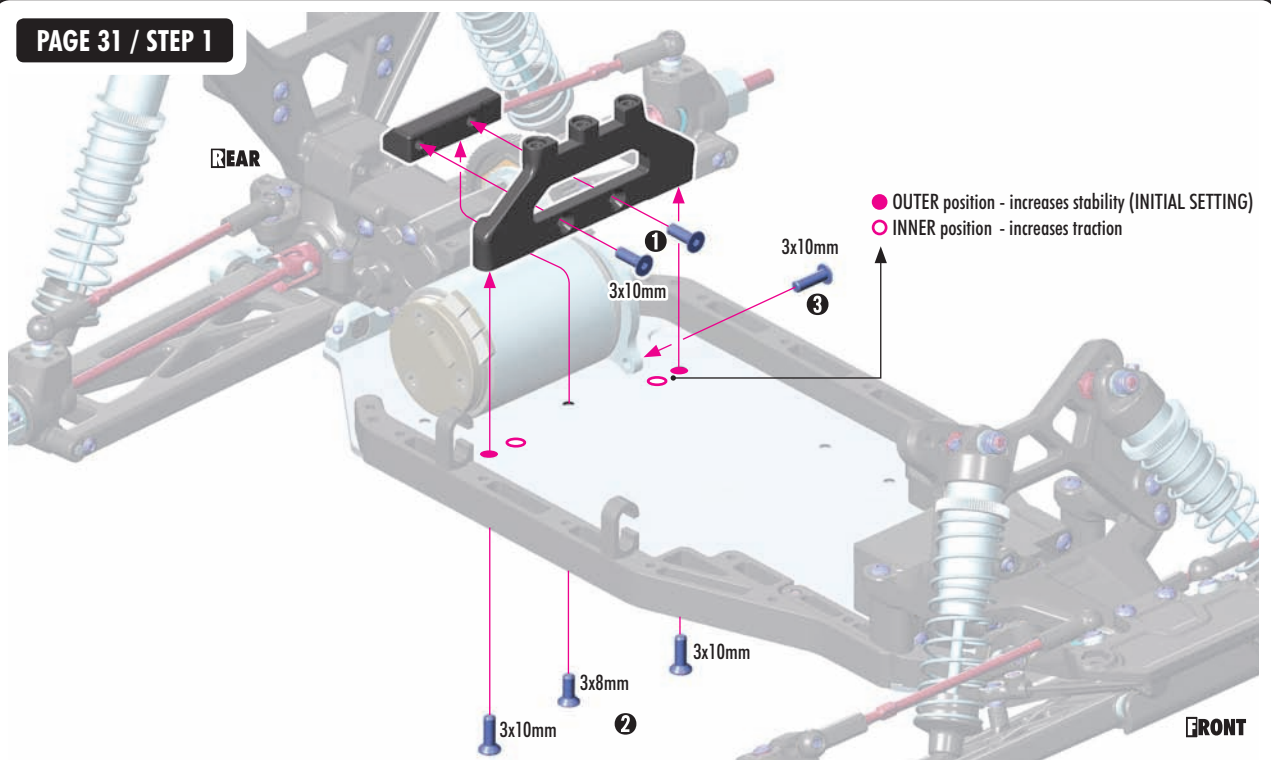

● OUTER position - increases stability (INITIAL SETTING)
○ INNER position - increases traction

SHOCK MAINTENANCE

The most important maintenance task for keeping consistent shock performance is refilling and bleeding them correctly. If built correctly, it will not be necessary to re-build them often. Replacing warped/hard o-rings, scarred piston rods, or shaved/split/loose composite upper and lower ball joints are also important.

- For club racing, it is recommended to check the shocks for air inside before each race and only re-fill and bleed them if necessary. Before each race day, make sure you take the spring off of each shock, hold it up to your ear, and quickly compress the shock rod fully into the body while listening for any air making a "whistling" or "squishy" sound as it passes through the piston holes. If you hear any air, refill and bleed your shocks. For high-competition racing, it is recommended that the shocks be re-filled and bled before a large event.
- If building or pairing new shocks, always make sure they are the same length using a shock length measuring tool and adjust the lower ball joints as needed.
- During regular shock operation, oil naturally gets on the shock shaft and drop-by-drop slightly gets out of the shock body. Shocks should be inspected regularly after each race, and oil replaced as required.

BEARING MAINTENANCE

Ball-bearings in an off-road car must be properly maintained for smooth operation and long lifespan.

The XB2 ball-bearings are degreased and are lubricated with HUDY Bearing Oil. The following procedures are recommended to clean all of the bearings in your off-road car. For high-competition racing, we recommended doing this every 3-4 weeks, or before a major race.

- 1 Remove the seals on both sides of the bearing (if present). If the seals bend a little and you can see a kink, carefully flatten the kink out by hand.
- 2 Spray the seals with motor cleaner and blow dry with compressed air.
- 3 Spray the bearing on both sides with motor cleaner.
- 4 Spin the bearing while it is still wet to dislodge any particles with the cleaner.
- 5 Spray the bearing on both sides again.
- 6 Blow both sides of the bearing dry with compressed air to make sure particles come out.
- 7 Hold the inner part of the bearing with my left thumb/forefinger and spin it to make sure it spins free without any abnormal vibrations or sounds.
- 8 Place one drop of bearing oil into each side of the bearing.
- 9 Replace both seals at the same time by lining them up on each side of the bearing and lightly pressing them in all the way around the bearings circumference with your thumb and forefinger. Do not press too hard or use any type of tool, such as a wrench tip, to push the blue seals in as they will push in too far, bend and cause drag.

If you spin test the bearing after you have re-oiled and sealed it, it will not spin freely for an extended period of time. The lightest of oils may allow it to spin for 1-2 seconds. This is normal and once you have mounted the bearings in the car again, the drive train will spin freely.

Make sure you use a motor cleaner that does not leave a residue after it dries as this may cause drag and wear in the bearings.

RECOMMENDED PRODUCTS

- Use #106230 HUDY Bearing Oil to lubricate the bearings.

HUDY #106230



SUSPENSION & DRIVETRAIN MAINTENANCE

- Check suspension for free movement during building and operation, and especially after running and if you have crashed the car. If the suspension does not move freely, use the appropriate HUDY Arm Reamer to clean and resize the holes of the suspension arms.
- Regularly check the drive shaft pins and if they show any wear must be immediately replaced by new pins. If the car is run with worn pins, excessive wear on the diff outrives will result. The #106000 HUDY Drive Pin Replacement Tool (for 3mm Pins) is a compact, rugged multi-use tool set for replacing 3mm drive pins in drive shafts. Use the HUDY replacement drive shaft pins 3x12 (#106051).
- Regularly inspect and replace the pins that connect the wheel drive shafts with wheel axles. Use HUDY Graphite Grease to lubricate the drive shaft connecting joints and the diff gears.
- Pivot balls and ball-joints will naturally wear for some time and will generate play. If there is too much play the pivot balls and ball joints need to be replaced.
- If the car is run in wet conditions, apply WD-40® on all drivetrain parts before the run. After the run, clean and dry the parts again.

HUDY #106210



HUDY SPRING STEEL™

The HUDY Spring Steel™ used in the car is the strongest and most durable steel material on the RC market. While items made from HUDY Spring Steel™ are still subject to wear, the lifespan is considerably longer than any other material. As parts made from HUDY Spring Steel™ wear, the

brown color will fade (get lighter) but it will not affect the strength of the material. The brown color is only a surface treatment and if the brown color will wear the durability of the part will be still strong.

RACE

TRACK

NAME DATE

LAPS BEST LAP TIME sec

QUALIFYING POSITION FINAL POSITION

TRACK

SIZE OPEN MEDIUM TIGHT

TRACTION VERY-LOW MEDIUM VERY-HIGH

SURFACE SMOOTH MEDIUM BUMPY

TYPE CLAY CARPET ASTRO

CONDITION BLUE GROOVE HARD PACKED DRY
 DUSTY LOAMY WET

TRANSMISSION

DIFFERENTIAL BALL DIFF GEAR DIFF OIL cst

SATELLITE GEARS COMPOSITE STEEL

SLIPPER ADJUSTMENT mm

GEARING

PINION T SPUR GEAR T

FRONT	SHOCKS	REAR
	SPRINGS	
cst	OIL	cst
%	REBOUND	%
<input type="checkbox"/> 2 HOLES <input type="checkbox"/>	PISTONS	<input type="checkbox"/> 2 HOLES <input type="checkbox"/>
<input type="checkbox"/> 3 HOLES <input type="checkbox"/>	<input type="checkbox"/> ø1.2mm <input type="checkbox"/>	<input type="checkbox"/> 3 HOLES <input type="checkbox"/>
<input type="checkbox"/> 6 HOLES <input type="checkbox"/>	<input type="checkbox"/> ø1.3mm <input type="checkbox"/>	<input type="checkbox"/> 6 HOLES <input type="checkbox"/>
<input type="checkbox"/> HOLES <input type="checkbox"/>	<input type="checkbox"/> ø1.4mm <input type="checkbox"/>	<input type="checkbox"/> HOLES <input type="checkbox"/>
	<input type="checkbox"/> ø1.6mm <input type="checkbox"/>	
	<input type="checkbox"/> ø1.7mm <input type="checkbox"/>	
DOWNSTOP SHIM	<input type="checkbox"/> mm	DOWNSTOP SHIM
INSERT UNDER PISTON		INSERT UNDER PISTON
LENGTH	<input type="checkbox"/> mm	LENGTH
UPSTOP SHIM	<input type="checkbox"/> mm	UPSTOP SHIM
INSERT ABOVE COLLAR		INSERT ABOVE COLLAR
KIT	<input type="checkbox"/>	KIT
	BALL JOINT	

SHOCK TOWER

FRONT GRAPHITE COMPOSITE REAR GRAPHITE COMPOSITE

ANTI ROLL BARS

FRONT mm THICKNESS mm REAR mm

TIRES

FRONT TYPE REAR TYPE

FRONT INSERTS REAR INSERTS

FRONT WHEELS REAR WHEELS

ELECTRONICS

MOTOR

SPEEDO

BATTERIES

ELECTRONICS LAYOUT

MOTOR POSITION FRONT MIDDLE REAR
 LEFT RIGHT

BATTERY POSITION FRONT MIDDLE REAR

BODY

STANDARD LIGHT OTHER

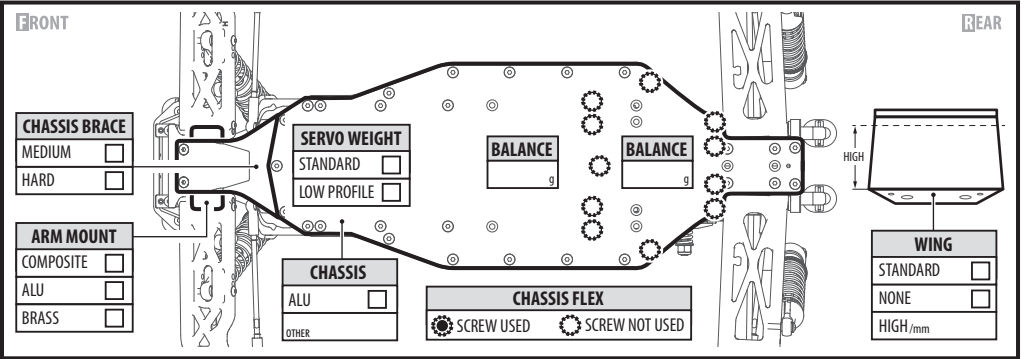
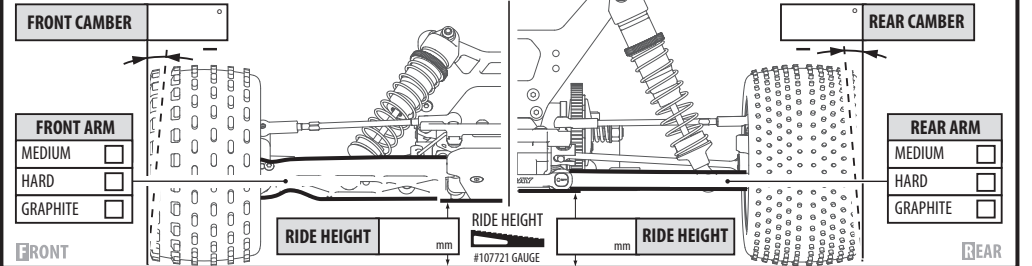
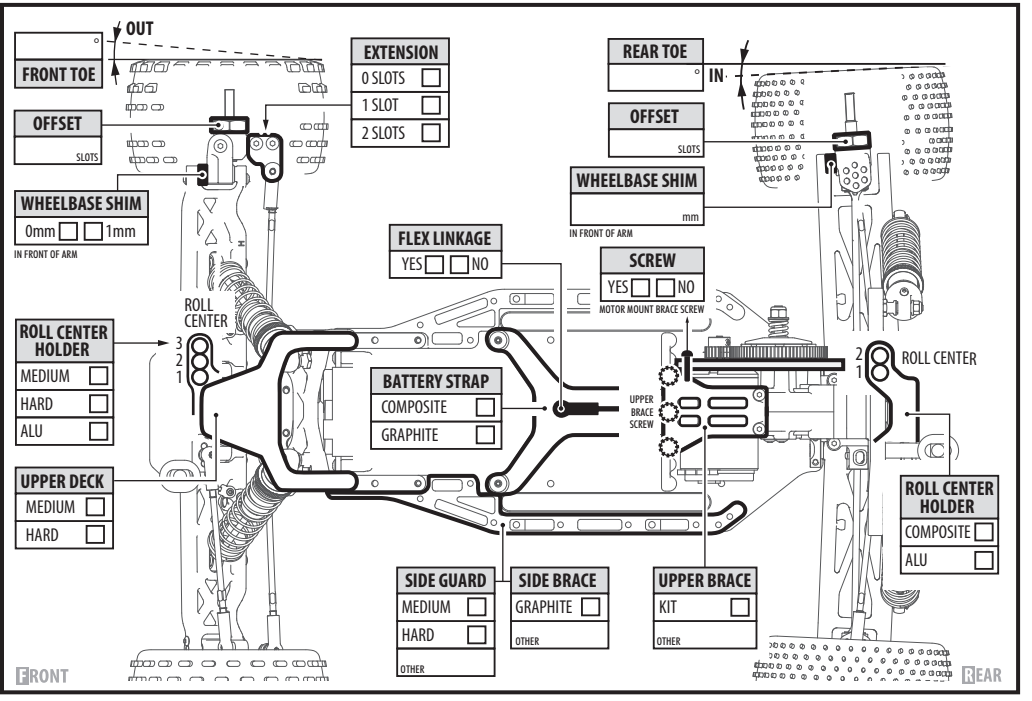
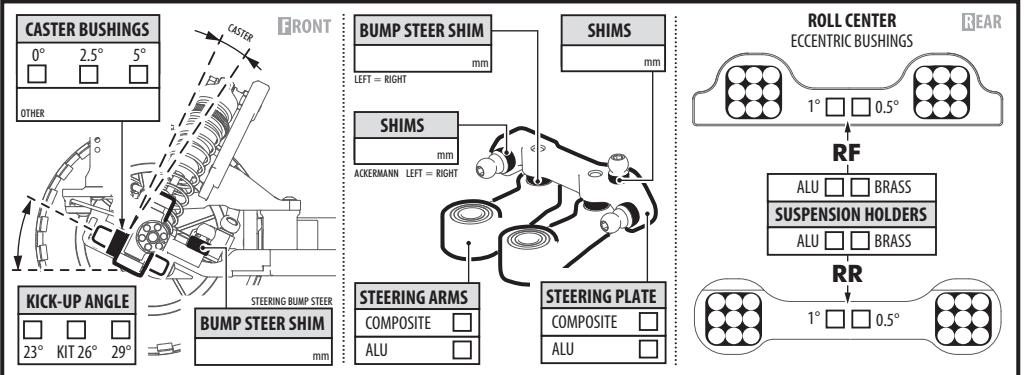
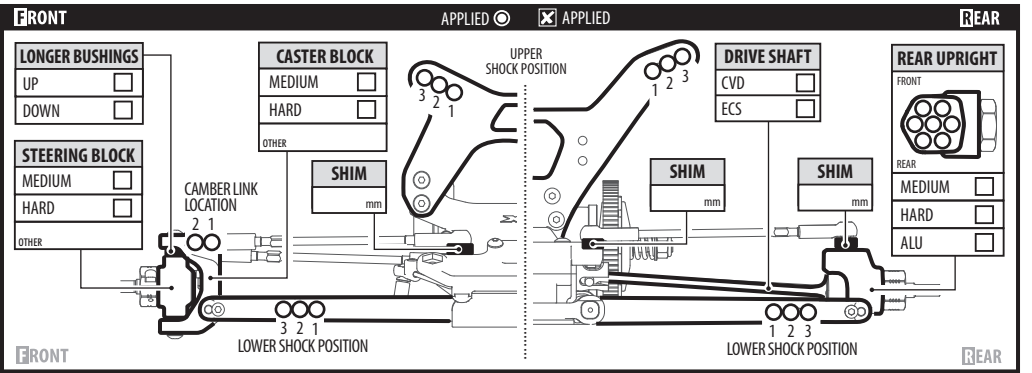

www.teamxray.com

XRAY EUROPE

XRAY, K VÝSTAVISKU 6992, 91101 TRENCIN, SLOVAKIA, EUROPE
PHONE: +421-32-740 11 00, FAX: +421-32-740 11 09, info@teamxray.com

XRAY USA

RC AMERICA, 2030 Century Center Blvd #15, Irving, TX 75062, USA
PHONE: 214-744-2400, FAX: 214-744-2401, xray@rcamerica.com



[/TeamXray](#)



[/TeamXray](#)



[/TeamXray](#)



[/XrayRacing](#)



[/+TeamXrayRC](#)