

1/10 LUXURY ELECTRIC TOURING CAR

# XRAY T4



**INSTRUCTION MANUAL**  
FOR T4'20 EDITION

## BEFORE YOU START

This is a high-competition, high-quality RC car intended for persons aged 16 years and older with previous experience building and operating RC model racing cars. This is not a toy; it is a precision racing model. This model racing car is not intended for use by beginners, inexperienced customers, or by children without direct supervision of a responsible, knowledgeable adult. If you do not fulfill these requirements, please return the kit in unused and unassembled form back to the shop where you have purchased it.

Before building and operating your XRAY, **YOU MUST** read through all of the operating instructions and instruction manual and fully understand them to get the maximum enjoyment and prevent unnecessary damage.

## CUSTOMER SUPPORT

We have made every effort to make these instructions as easy to understand as possible. However, if you have any difficulties, problems, or questions, please do not hesitate to contact the XRAY support team at [info@teamxray.com](mailto:info@teamxray.com). Also, please visit our Web site at [www.teamxray.com](http://www.teamxray.com) to find the latest updates, set-up information, option parts, and many other goodies. We pride ourselves on taking excellent care of our customers.

You can join thousands of XRAY fans and enthusiasts in our online community at: [www.teamxray.com](http://www.teamxray.com)

Read carefully and fully understand the instructions before beginning assembly.

Make sure you review this entire manual, download and use set-up book from the web, and examine all details carefully. If for some reason you decide this is not what you wanted or expected, **do not continue any further**. Your hobby dealer can not accept your kit for return or exchange after it has been partially or fully assembled.

Contents of the box may differ from pictures. In line with our policy of continuous product development, the exact specifications of the kit may vary without prior notice.

### XRAY Europe

K Vystavisku 6992  
91101 Trenčín  
Slovakia, EUROPE  
Phone: 421-32-7401100  
Fax: 421-32-7401109  
E-mail: [info@teamxray.com](mailto:info@teamxray.com)

### XRAY USA

RC America, 2030 Century Blvd #15  
Irving, TX 75062  
USA  
Phone: (214) 744-2400  
Fax: (214) 744-2401  
E-mail: [xray@rcamerica.com](mailto:xray@rcamerica.com)

**FAILURE TO FOLLOW THESE INSTRUCTIONS WILL BE CONSIDERED AS ABUSE AND/OR NEGLECT.**

## SAFETY PRECAUTIONS

Contains:

LEAD (CAS 7439-92-1) ANTIMONY (CAS 7440-36-0)

WARNING: This product contains a chemical known to the state of California to cause cancer and birth defects or other reproductive harm.

CAUTION: CANCER HAZARD

Contains lead, a listed carcinogen. Lead is harmful if ingested. Wash thoroughly after using. DO NOT use product while eating, drinking or using tobacco products. May cause chronic effects to gastrointestinal tract, CNS, kidneys, and blood. MAY CAUSE BIRTH DEFECTS.

When building, using and/or operating this model always wear protective glasses and gloves.

Take appropriate safety precautions prior to operating this model. You are responsible for this model's assembly and safe operation! Please read the instruction manual before building and operating this model and follow all safety precautions. Always keep the instruction manual at hand for quick

reference, even after completing the assembly. Use only genuine and original authentic XRAY parts for maximum performance. Using any third party parts on this model will void warranty immediately.

Improper operation may cause personal and/or property damage. XRAY and its distributors have no control over damage resulting from shipping, improper construction, or improper usage. XRAY assumes and accepts no responsibility for personal and/or property damages resulting from the use of improper building materials, equipment and operations. By purchasing any item produced by XRAY, the buyer expressly warrants that he/she is in compliance with all applicable federal, state and local laws and regulation regarding the purchase, ownership and use of the item. The buyer expressly agrees to indemnify and hold harmless XRAY for all claims resulting directly or indirectly from the purchase, ownership or use of the product. By the act of assembling or operating this product, the user accepts all resulting liability. If the buyer is not prepared to accept this liability, then he/she should return this kit in new, unassembled, and unused condition to the place of purchase.

## IMPORTANT NOTES - GENERAL

- This product is not suitable for children under 16 years of age without the direct supervision of a responsible and knowledgeable adult.
- Carefully read all manufacturers warnings and cautions for any parts used in the construction and use of your model.
- Assemble this kit only in places away from the reach of very small children.
- First-time builders and users should seek advice from people who have building experience in order to assemble the model correctly and to allow the model to reach its performance potential.
- Exercise care when using tools and sharp instruments.
- Take care when building, as some parts may have sharp edges.
- Keep small parts out of reach of small children. Children must not be allowed to put any parts in their mouth, or pull vinyl bag over their head.
- Read and follow instructions supplied with paints and/or cement, if used (not included in kit).
- Immediately after using your model, do NOT touch equipment on the model such as the motor and speed controller, because they generate high temperatures. You may seriously burn yourself seriously touching them.
- Follow the operating instructions for the radio equipment at all times.
- Do not put fingers or any objects inside rotating and moving parts, as this may cause damage or serious injury as your finger, hair, clothes, etc. may get caught.
- Be sure that your operating frequency is clear before turning on or running your model, and never share the same frequency with somebody else at the same time. Ensure that others are aware of the operating frequency you are using and when you are using it.
- Use a transmitter designed for ground use with RC cars. Make sure that no one else is using the same frequency as yours in your operating area. Using the same frequency at the same time, whether it is driving, flying or sailing, can cause loss of control of the RC model, resulting in a serious accident.
- Always turn on your transmitter before you turn on the receiver in the car. Always turn off the receiver before turning your transmitter off.
- Keep the wheels of the model off the ground when checking the operation of the radio equipment.
- Disconnect the battery pack before storing your model.
- When learning to operate your model, go to an area that has no obstacles that can damage your model if your model suffers a collision.
- Remove any sand, mud, dirt, grass or water before putting your model away.
- If the model behaves strangely, immediately stop the model, check and clear the problem.
- To prevent any serious personal injury and/or damage to property, be responsible when operating all remote controlled models.
- The model car is not intended for use on public places and roads or areas where its operation can conflict with or disrupt pedestrian or vehicular traffic.
- Because the model car is controlled by radio, it is subject to radio interference from many sources that are beyond your control. Since radio interference can cause momentary loss of control, always allow a safety margin in all directions around the model in order to prevent collisions.
- Do not use your model:
  - Near real cars, animals, or people that are unaware that an RC car is being driven.
  - In places where children and people gather
  - In residential districts and parks
  - In limited indoor spaces
  - In wet conditions
  - In the street
  - In areas where loud noises can disturb others, such as hospitals and residential areas.
  - At night or anytime your line of sight to the model may be obstructed or impaired in any way.

To prevent any serious personal injury and/or damage to property, please be responsible when operating all remote controlled models.

## **IMPORTANT NOTES – ELECTRICAL**

- Insulate any exposed electrical wiring (using heat shrink tubing or electrical tape) to prevent dangerous short circuits. Take maximum care in wiring, connecting and insulating cables. Make sure cables are always connected securely. Check connectors for if they become loose. And if so, reconnect them securely. Never use RC models with damaged wires. A damaged wire is extremely dangerous, and can cause short-circuits resulting in fire. Please have wires repaired at your local hobby shop.
- Low battery power will result in loss of control. Loss of control can occur due to a weak battery in either the transmitter or the receiver. Weak running battery may also result in an out of control car if your car's receiver power is supplied by the running battery. Stop operation immediately if the car starts to slow down.
- When not using RC model, always disconnect and remove battery.
- Do not disassemble battery or cut battery cables. If the running battery short-circuits, approximately 300W of electricity can be discharged, leading to fire or burns. Never disassemble battery or cut battery cables.
- Use a recommended charger for the receiver and transmitter batteries and follow the instructions correctly. Over-charging, incorrect charging,

or using inferior chargers can cause the batteries to become dangerously hot. Recharge battery when necessary. Continual recharging may damage battery and, in the worst case, could build up heat leading to fire. If battery becomes extremely hot during recharging, please ask your local hobby shop for check and/or repair and/or replacement.

- Regularly check the charger for potential hazards such as damage to the cable, plug, casing or other defects. Ensure that any damage is rectified before using the charger again. Modifying the charger may cause short-circuit or overcharging leading to a serious accident. Therefore do not modify the charger.
- Always unplug charger when recharging is finished.
- Do not recharge battery while battery is still warm. After use, battery retains heat. Wait until it cools down before charging.
- Do not allow any metal part to short circuit the receiver batteries or other electrical/electronic device on the model.
- Immediately stop running if your RC model gets wet as may cause short circuit.
- Please dispose of batteries responsibly. Never put batteries into fire.

## **R/C & BUILDING TIPS**

- Make sure all fasteners are properly tightened. Check them periodically.
- Make sure that chassis screws do not protrude from the chassis.
- For the best performance, it is very important that great care is taken to ensure the free movement of all parts.
- Clean all ball-bearings so they move very easily and freely.
- Tap or pre-thread the plastic parts when threading screws.
- Self-tapping screws cut threads into the parts when being tightened. Do not use excessive force when tightening the self-tapping screws because you may strip out the thread in the plastic. We recommended you stop tightening a screw when you feel some resistance.
- Ask your local hobby shop for any advice.

Please support your local hobby shop. We at XRAY Model Racing Cars support all local hobby dealers. Therefore we ask you, if at all possible, to purchase XRAY products at your hobby dealer and give them your support like we do. If you have difficulty finding XRAY products, please check out [www.teamxray.com](http://www.teamxray.com) to get advice, or contact us via email at [info@teamxray.com](mailto:info@teamxray.com), or contact the XRAY distributor in your country.

## **WARRANTY**

XRAY guarantees this model kit to be free from defects in both material and workmanship within 30 days of purchase. The total monetary value under warranty will in no case exceed the cost of the original kit purchased. This warranty does not cover any components damaged by use or modification or as a result of wear. Part or parts missing from this kit must be reported within 30 days of purchase. No part or parts will be sent under warranty without proof of purchase. Should you find a defective or missing part, contact the local distributor. Service and customer support will be provided through local hobby store where you have purchased the kit, therefore make sure to purchase any XRAY products at your local hobby store. This model racing car is considered to be a high-performance racing vehicle. As such this vehicle will be used in an extreme range of conditions and situations, all which may cause premature wear or failure of any component. XRAY has no control over usage of vehicles once they leave the dealer, therefore XRAY can only offer warranty against all manufacturer's defects in materials, workmanship, and assembly at point of sale and before use. No warranties are expressed or implied that cover damage caused by what is considered normal use, or cover or imply how long any model cars' components or electronic components will last before requiring replacement.

Due to the high performance level of this model car you will need to periodically maintain and replace consumable components. Any and all warranty coverage will not cover replacement of any part or component damaged by neglect, abuse, or improper or unreasonable use. This includes

but is not limited to damage from crashing, chemical and/or water damage, excessive moisture, improper or no maintenance, or user modifications which compromise the integrity of components. Warranty will not cover components that are considered consumable on RC vehicles. XRAY does not pay nor refund shipping on any component sent to XRAY or its distributors for warranty. XRAY reserves the right to make the final determination of the warranty status of any component or part.

### **Limitations of Liability**

XRAY makes no other warranties expressed or implied. XRAY shall not be liable for any loss, injury or damages, whether direct, indirect, special, incidental, or consequential, arising from the use, misuse, or abuse of this product and/or any product or accessory required to operate this product. In no case shall XRAY's liability exceed the monetary value of this product.

**Take adequate safety precautions prior to operating this model. You are responsible for this model's assembly and safe operation.**

**Disregard of the any of the above cautions may lead to accidents, personal injury, or property damage. XRAY MODEL RACING CARS assumes no responsibility for any injury, damage, or misuse of this product during assembly or operation, nor any additions that may arise from the use of this product.**

**All rights reserved.**

## **QUALITY CERTIFICATE**

XRAY MODEL RACING CARS uses only the highest quality materials, the best compounds for molded parts and the most sophisticated manufacturing processes of TQM (Total Quality Management). We guarantee that all parts of a newly-purchased kit are manufactured with the highest regard to quality. However, due to the many factors inherent in model racecar competition, we

cannot guarantee any parts once you start racing the car. Products which have been worn out, abused, neglected or improperly operated will not be covered under warranty.

We wish you enjoyment of this high-quality and high-performance RC car and wish you best success on the track!

**In line with our policy of continuous product development, the exact specifications of the kit may vary. In the unlikely event of any problems with your new kit, you should contact the model shop where you purchased it, quoting the part number.**

**We do reserve all rights to change any specification without prior notice. All rights reserved.**

# SYMBOLS USED

<b>Part bags used</b> 	<b>Assemble in the specified order</b> 	<b>Assemble left and right sides the same way</b> 	<b>Pay attention here</b> 	<b>Assemble as many times as specified (here twice)</b> 	<b>Apply thread lock</b> 	<b>Apply CA glue</b> 	<b>Apply oil</b> 
<b>Scale</b> 	<b>Apply grease</b> 	<b>Optional parts</b> 	<b>Ensure smooth non-binding movement</b> 	<b>Tighten screw gently</b> 	<b>Completed assembly</b> 	<b>Detail view</b> 	<b>Follow Set-up Book</b> 

# TOOLS REQUIRED

**HUDY TOOLS:**

<p>Allen: 1.5mm</p>	<p>Allen: 2.0mm</p>	<p>Allen: 3.0mm</p>	<p>Socket: 5.5mm</p>	<p>Socket: 7.0mm</p>	<p>Arm Reamer 3.0mm</p>	<p>Turnbuckle Wrench 4mm (HUDY #181040)</p> <p>Turnbuckle Wrench 3mm (HUDY #181030)</p>
<p>Scissors (HUDY #188990)</p>	<p>Combination Pliers (HUDY #189020)</p>	<p>Side Cutters (HUDY #189010)</p>	<p>Pocket Hobby Knife (HUDY #188981)</p>	<p>Professional Multi Tool (HUDY #183011)</p>	<p>Reamer (HUDY #107600) or (HUDY #107601)</p>	<p>Snap Ring Pliers</p>

# ITEMS INCLUDED

<p>Premium Silicone Oil 450cSt (HUDY #106345)</p>	<p>Premium Silicone Oil 5.000cSt (HUDY #106450)</p>
<p>Graphite Grease (HUDY #106210)</p>	

# NOT INCLUDED

	<p>To ensure that you always have access to the most up-to-date version of the XRAY Set-up Book, XRAY will now be offering only the digital online version on our website <a href="http://www.teamxray.com">www.teamxray.com</a>. By offering this online version instead of including a hardcopy printed version in kits, you will always be assured of having the most current updated version.</p>						
<p><b>SAMPLE OF OPTIONAL PARTS</b></p> <table border="1"> <tr> <td>#30XXX</td> <td>OPTION 1</td> </tr> <tr> <td>#30XXX</td> <td>OPTION 2</td> </tr> <tr> <td>#30XXX</td> <td>OPTION 3</td> </tr> </table>	#30XXX	OPTION 1	#30XXX	OPTION 2	#30XXX	OPTION 3	<p>XRAY offers wide range of optional tuning parts which are listed in tables like these. Please refer to the exploded view of each main section to verify which part is included in the kit while all other parts are available only as an optional part and must be purchased separately.</p>
#30XXX	OPTION 1						
#30XXX	OPTION 2						
#30XXX	OPTION 3						

# EQUIPMENT REQUIRED

<p>Transmitter</p>	<p>Receiver</p>	<p>Steering Servo</p>	<p>Electric Motor &amp; Pinion Gear and Setscrew</p>	<p>Bearing Oil (HUDY #106230)</p>	<p>Speed Controller</p>
<p>190mm Bodysell</p>	<p>LiPo Battery</p>	<p>Lexan™ Paint</p>	<p>Battery Charger</p>	<p>Fibre Tape (HUDY #107870) Double-sided Tape (HUDY #107875)</p>	<p>Wheels &amp; Tires &amp; Inserts (HUDY #803053 C3-28) (HUDY #803062 A1-36)</p>

# COLOR INDICATIONS

At the beginning of each section is an exploded view of the parts to be assembled. There is also a list of all the parts and part numbers that are related to the assembly of that section.

The part descriptions are color-coded to make it easier for you to identify the source of a part. Here are what the different colors mean:

STYLE A - indicates parts that are included in the bag marked for the section.

STYLE B - indicates parts that are included in the box.

STYLE C - indicates parts that are already assembled from previous steps.

# CHASSIS PREPARATION

To protect and seal edges of graphite parts, sand edges smooth and then apply CA glue.

Do this for: chassis edges, countersunk holes, and shock towers.

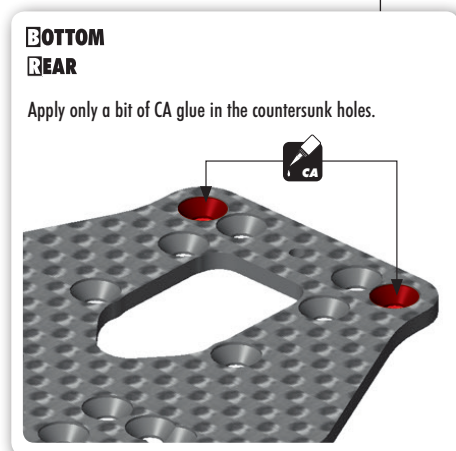
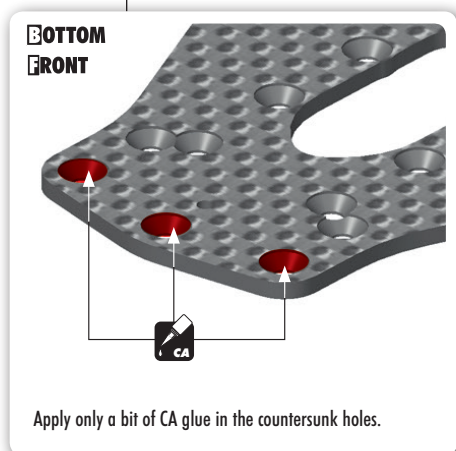
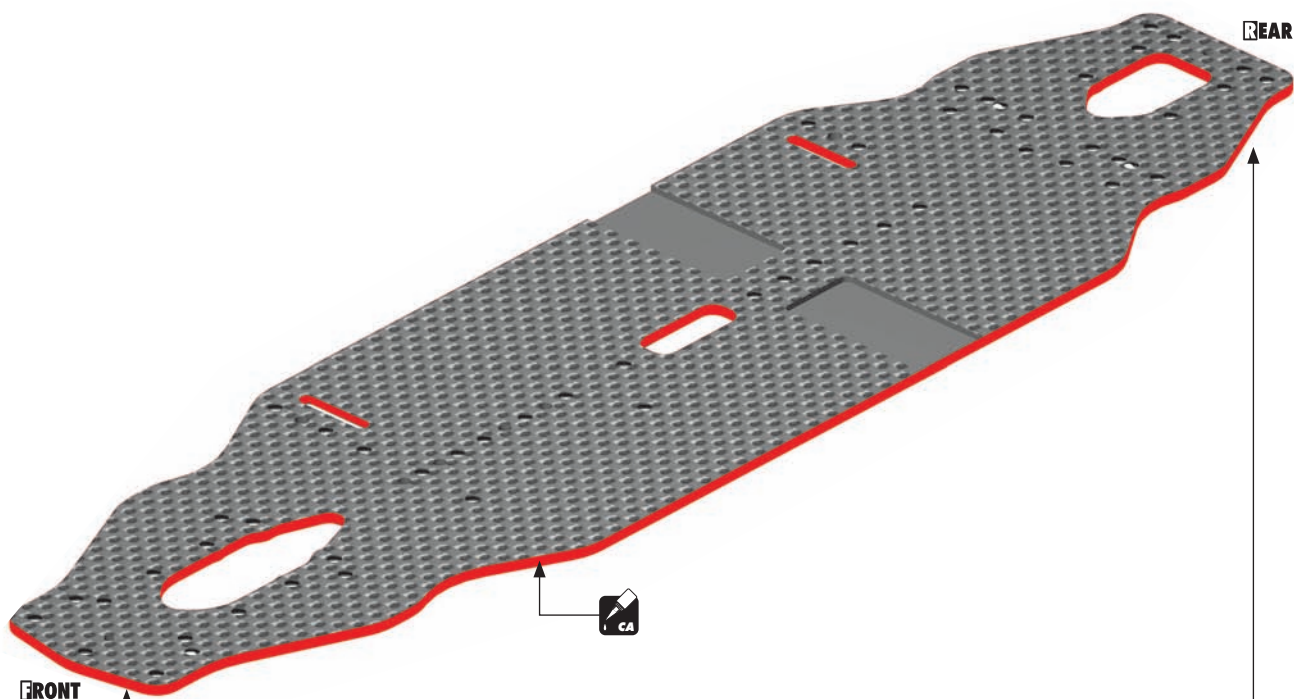

# 1. GEAR DIFFERENTIAL & FRONT SOLID AXLE

**#304932**  
OPTION  
GRAPHITE GEAR DIFF BEVEL & SATELLITE GEARS (2+4)

**#309002**  
OPTION  
SET OF CERAMIC BALL-BEARINGS (14)

**#304971**  
OPTION  
HUDY SPRING STEEL™ OUTDRIVES

**#305136**  
OPTION  
ALU SOLID DRIVESHAFT ADAPTERS

**#305137**  
OPTION  
STEEL SOLID AXLE DRIVESHAFT ADAPTERS  
HUDY SPRING STEEL™

**01.2**  
GEAR DIFFERENTIAL

**01.1**  
COMPOSITE SOLID AXLE

<b>BAG</b>	<p><b>01.1</b></p> <p><b>01.2</b></p>	<table border="0"> <tr> <td>304900</td> <td>XRAY GEAR DIFFERENTIAL - SET</td> <td>902310</td> <td>HEX SCREW SH M3x10 (10)</td> </tr> <tr> <td>304910</td> <td>COMPOSITE GEAR DIFF CASE &amp; COVER</td> <td>903256</td> <td>HEX SCREW SFH M2.5x6 (10)</td> </tr> <tr> <td>304930</td> <td>COMPOSITE GEAR DIFF BEVEL &amp; SATELLITE GEARS (2+4)</td> <td>941015</td> <td>BALL-BEARING 10x15x4 RUBBER SEALED - OIL (2)</td> </tr> <tr> <td>304970</td> <td>ALU GEAR DIFF OUTDRIVE ADAPTER - 7075 T6 (2)</td> <td>964031</td> <td>WASHER S 3.5x10x0.2 (10)</td> </tr> <tr> <td>304980</td> <td>COMPOSITE GEAR DIFF CROSS PIN</td> <td>964050</td> <td>WASHER S 5x15x0.3 (10)</td> </tr> <tr> <td>304990</td> <td>DIFF GASKET (4)</td> <td>971240</td> <td>SILICONE O-RING 24x0.7 (10)</td> </tr> <tr> <td>305135</td> <td>COMPOSITE SOLID AXLE DRIVESHAFT ADAPTERS (2)</td> <td>972050</td> <td>SILICONE O-RING 5x2 (10)</td> </tr> <tr> <td>305188</td> <td>COMPOSITE SOLID AXLE 38T - SET</td> <td>981210</td> <td>PIN 2x10 (10)</td> </tr> </table>	304900	XRAY GEAR DIFFERENTIAL - SET	902310	HEX SCREW SH M3x10 (10)	304910	COMPOSITE GEAR DIFF CASE & COVER	903256	HEX SCREW SFH M2.5x6 (10)	304930	COMPOSITE GEAR DIFF BEVEL & SATELLITE GEARS (2+4)	941015	BALL-BEARING 10x15x4 RUBBER SEALED - OIL (2)	304970	ALU GEAR DIFF OUTDRIVE ADAPTER - 7075 T6 (2)	964031	WASHER S 3.5x10x0.2 (10)	304980	COMPOSITE GEAR DIFF CROSS PIN	964050	WASHER S 5x15x0.3 (10)	304990	DIFF GASKET (4)	971240	SILICONE O-RING 24x0.7 (10)	305135	COMPOSITE SOLID AXLE DRIVESHAFT ADAPTERS (2)	972050	SILICONE O-RING 5x2 (10)	305188	COMPOSITE SOLID AXLE 38T - SET	981210	PIN 2x10 (10)
304900	XRAY GEAR DIFFERENTIAL - SET	902310	HEX SCREW SH M3x10 (10)																															
304910	COMPOSITE GEAR DIFF CASE & COVER	903256	HEX SCREW SFH M2.5x6 (10)																															
304930	COMPOSITE GEAR DIFF BEVEL & SATELLITE GEARS (2+4)	941015	BALL-BEARING 10x15x4 RUBBER SEALED - OIL (2)																															
304970	ALU GEAR DIFF OUTDRIVE ADAPTER - 7075 T6 (2)	964031	WASHER S 3.5x10x0.2 (10)																															
304980	COMPOSITE GEAR DIFF CROSS PIN	964050	WASHER S 5x15x0.3 (10)																															
304990	DIFF GASKET (4)	971240	SILICONE O-RING 24x0.7 (10)																															
305135	COMPOSITE SOLID AXLE DRIVESHAFT ADAPTERS (2)	972050	SILICONE O-RING 5x2 (10)																															
305188	COMPOSITE SOLID AXLE 38T - SET	981210	PIN 2x10 (10)																															

**964050**  
S 5x15x0.3

**972050**  
O 5x2

**981210**  
P 2x10

**STEP 4 5 DETAIL**

**#304971**  
OPTION  
HUDY SPRING STEEL™ OUTDRIVES

**#304932**  
OPTION  
GRAPHITE GEAR DIFF BEVEL & SATELLITE GEARS (2+4)

**964050**  
S 5x15x0.3

**972050**  
O 5x2

**981210**  
P 2x10

**NOTE ORIENTATION**

**STEP 4 DETAIL**  
Use tweezers to insert pin.

**CUTAWAY VIEW**

# 1. GEAR DIFFERENTIAL & FRONT SOLID AXLE



964031  
3.5x10x0.2

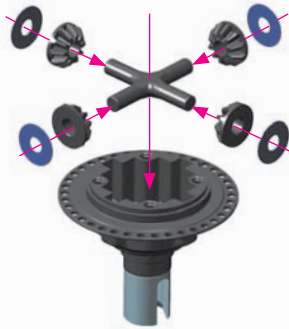

**#304932**  
OPTION GRAPHITE GEAR DIFF BEVEL & SATELLITE GEARS (2+4)

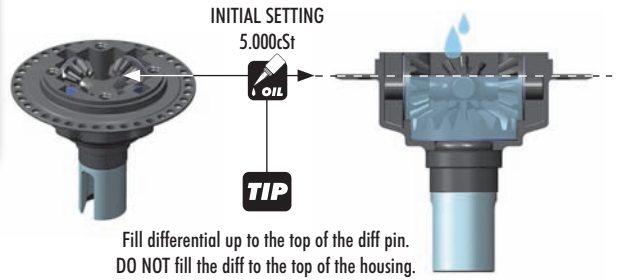

Fill differential up to the top of the diff pin.  
DO NOT fill the diff to the top of the housing.

**TO ENSURE YOU HAVE THE SAME AMOUNT OF OIL FROM REBUILD TO REBUILD, DO THE FOLLOWING:**

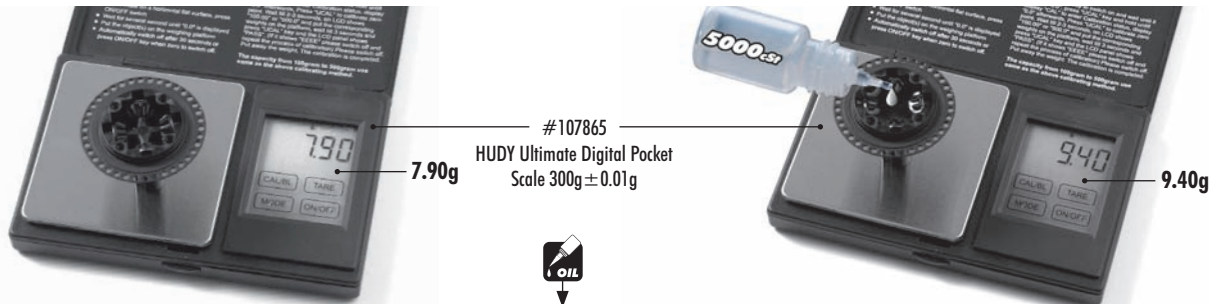

1 Put the diff (without oil) on the scale and check the weight (approximately 7.90g)

$$7.9g + 1.5g = 9.4g$$

2 Slowly pour oil into the diff and watch the weight. Add 1.5g of oil into the diff. The approximate weight of the diff including oil is 9.40g.

**TIP**

## TIPS FOR DIFFERENTIALS

**TIP**

### LOW TRACTION

1.000cSt (HUDY #106410)  
2.000cSt (HUDY #106420)

### MEDIUM TRACTION

2.000cSt (HUDY #106420)  
3.000cSt (HUDY #106430)  
4.000cSt (HUDY #106440)  
5.000cSt (HUDY #106450)

### HIGH TRACTION

5.000cSt (HUDY #106450)  
6.000cSt (HUDY #106460)  
7.000cSt (HUDY #106470)  
8.000cSt (HUDY #106480)  
9.000cSt (HUDY #106490)  
10.000cSt (HUDY #106510)

### SUPER-HIGH TRACTION

10.000cSt (HUDY #106510)  
15.000cSt (HUDY #106515)  
20.000cSt (HUDY #106520)

### NOTE

SOFTER oil increases rear traction, HARDER oil increases on-power steering and stability. It is important not to use soft oils in high-traction conditions as this would not increase traction, but would make the car loose as the car would become too twitchy.

However, if the oil is too soft, it could generate the same effect like the car has no traction. Therefore it is very important to choose the correct oil very carefully. We recommend using softer oil first, then try harder oil to better understand the effect on the car's behavior at the track. Choose the oil accordingly.



#104002  
HUDY AIR VAC – VACUUM PUMP

**TIP**

To make sure that all the air is removed from the diff oil, we recommend using the HUDY Air Vac.



### TIPS FOR FRONT DIFFERENTIAL

To increase on-power steering and cornering speed, the gear diff can also be used in the front.  
**NOTE:** If you use the gear diff in the front, we recommend using optional #304971 HUDY Spring Steel™ outdrives because the stress on the outdrives in the front is much higher than in the rear.

### USE THESE OILS FOR FRONT DIFFERENTIAL

500.000cSt (HUDY #106650)  
1 000.000cSt (HUDY #106692)  
2 000.000cSt (HUDY #106694)

To make the front differential tighter, you can use cleaning gum instead of oil.

### IMPORTANT!

Using cleaning gum instead of oil in the gear differential can lead to gear breakage because the gears are working under dry conditions.

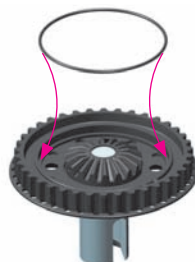
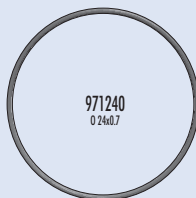

After disassembling the gear diff the large O-ring may have an increased size and may be more difficult to re-install. We recommend either inserting the old O-ring carefully in the diff cover, or replacing the old O-ring with a new O-ring if the old one cannot be made to fit properly.

# 1. GEAR DIFFERENTIAL & FRONT SOLID AXLE



**BOTTOM**

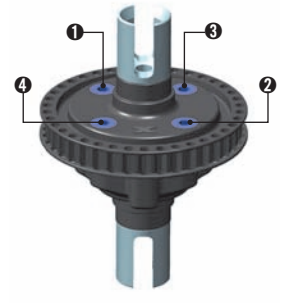
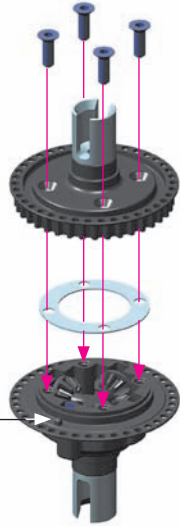
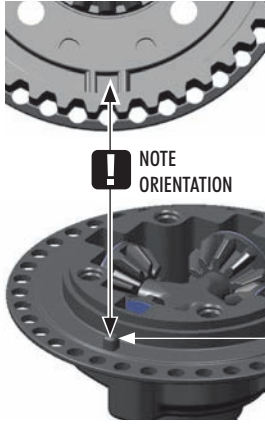

Finish tightening in this order.

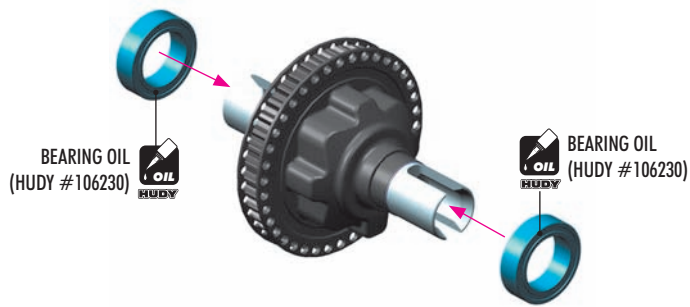

## COMPOSITE FRONT SOLID AXLE

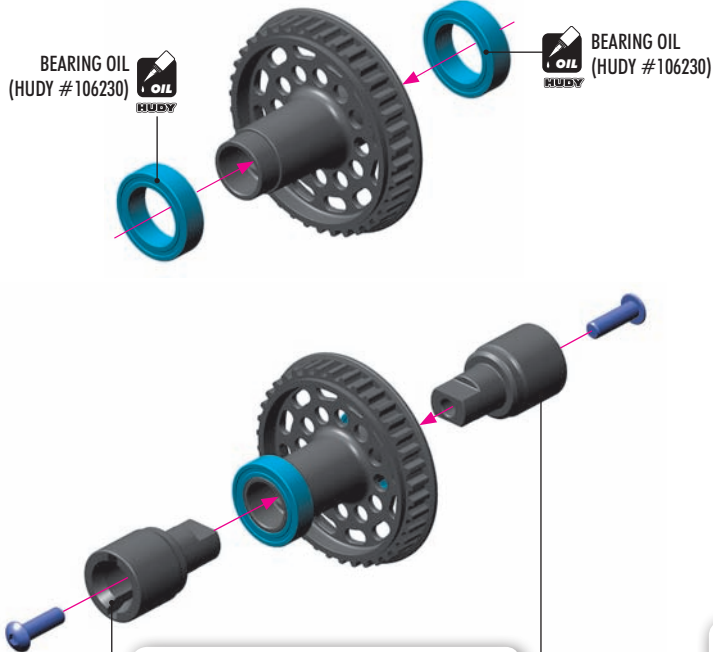

**#305137**  
STEEL SOLID AXLE DRIVESHAFT ADAPTERS  
HUDY SPRING STEEL™



**#305136**  
ALU SOLID DRIVESHAFT ADAPTERS



CUTAWAY VIEW

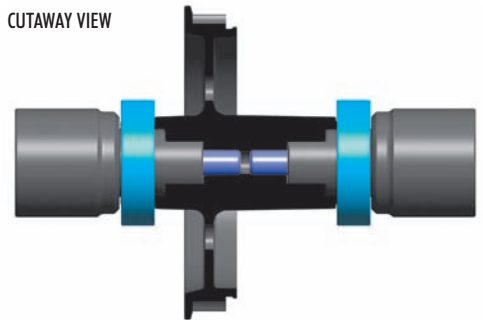

FRONT & REAR AXLES



## 2. CENTRAL TRANSMISSION

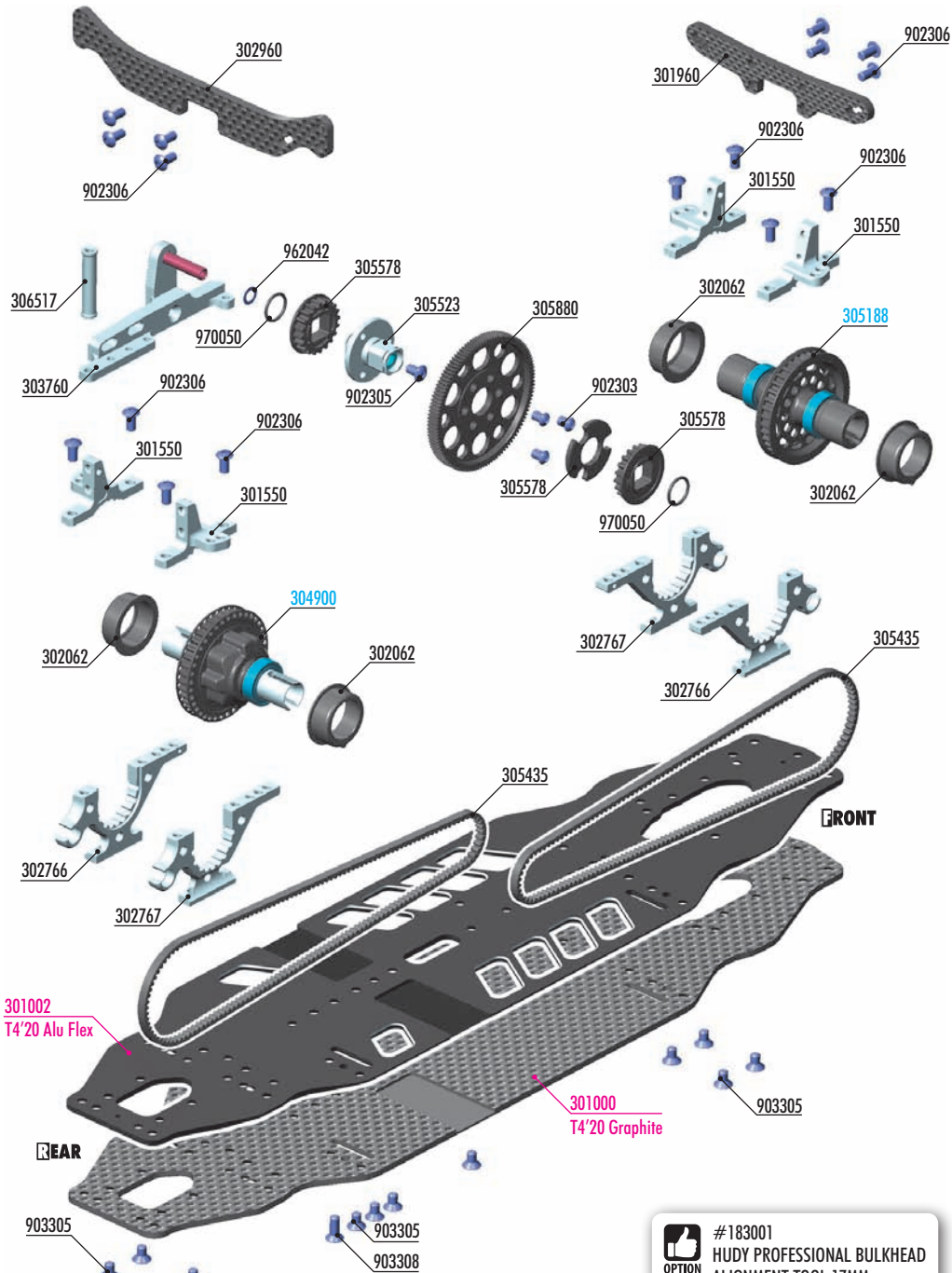

### OFFSET SPUR GEARS 48P

#305772	72T / 48P	OPTION
#305776	76T / 48P	OPTION
#305778	78T / 48P	OPTION
#305779	79T / 48P	OPTION
#305781	81T / 48P	OPTION
#305784	84T / 48P	OPTION
#305784-0	84T / 48P	OPTION



### OFFSET SPUR GEARS 64P

#305860	90T / 64P	OPTION
#305862	92T / 64P	OPTION
#305866	96T / 64P	OPTION
#305866-0	96T / 64P	OPTION
#305869	99T / 64P	OPTION
#305870	100T / 64P	OPTION
#305870-0	100T / 64P	OPTION
#305874	104T / 64P	OPTION
#305876	106T / 64P	OPTION
#305878	108T / 64P	OPTION
#305880	110T / 64P	INCLUDED
#305880-0	110T / 64P	OPTION
#305882	112T / 64P	OPTION
#305884	114T / 64P	OPTION



#305578-0  
FIXED PULLEY 20T - GRAPHITE (2)



#302063  
ALU ADJUSTMENT BALL-BEARING HUB (2)



#183001  
HUDY PROFESSIONAL BULKHEAD  
ALIGNMENT TOOL 17MM



#301001  
T4'20 ALU SOLID CHASSIS 2.0mm

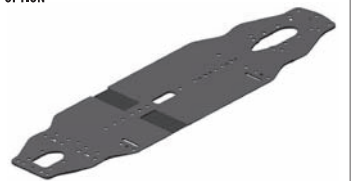

#305436  
HIGH-PERFORMANCE DRIVE BELT LOW-FRICTION 3x351MM



BAG

02

- 301550 T4'20 ALU UPPER CLAMP WITH 2 ADJ. ROLL-CENTERS (L+R)
- 301960 T4'20 ULP GRAPHITE SHOCK TOWER FRONT 3.0MM
- 302062 T4 COMPOSITE ADJUSTMENT BALL-BEARING HUB (4)
- 302766 T4'20 ALU LOWER ADJUSTMENT BULKHEAD - FRONT R / REAR L
- 302767 T4'20 ALU LOWER ADJUSTMENT BULKHEAD - FRONT L / REAR R
- 302960 T4'20 ULP GRAPHITE SHOCK TOWER REAR 3.0MM
- 303760 T4'20 ALU MOTOR MOUNT
- 305435 HIGH-PERFORMANCE DRIVE BELT 3x351MM
- 305523 ALU SOLID LAYSHAFT WITH BEARINGS
- 305578 FIXED PULLEY FOR LAYSHAFT WITH BEARINGS 20T (2)
- 305880 OFFSET SPUR GEAR 110T / 64
- 306517 T4'20 ALU TOP DECK MOUNT

- 902303 HEX SCREW SH M3x4 SMALL HEAD - STAINLESS (10)
- 902305 HEX SCREW SH M3x5 (10)

- 902306 HEX SCREW SH M3x6 (10)
- 903305 HEX SCREW SFH M3x5 (10)
- 903308 HEX SCREW SFH M3x8 (10)
- 962042 WASHER S 4x6x0.1 (10)
- 970050 O-RING 5x1 (10)

- 304900 XRAY GEAR DIFFERENTIAL - SET
- 305188 COMPOSITE SOLID AXLE 38T - SET

- 301000 T4'20 GRAPHITE CHASSIS 2.2MM
- 301002 T4'20 ALU FLEX CHASSIS 2.0MM - SWISS 7075 T6

## 2. CENTRAL TRANSMISSION



903305  
SFH M3x5

**DETAIL** NOTE ORIENTATION

**FRONT**

**REAR**

**OPTION** #183001 HUDY PROFESSIONAL BULKHEAD ALIGNMENT TOOL 17MM

To align the bulkheads straight, we suggest using the HUDY Professional Bulkhead Alignment tool.

See page 12, step 4

**FRONT SOLID AXLE**

**REAR GEAR DIFF**

**LONGER**

**SHORTER**

**OPTION** #302063 ALU ADJUSTMENT BALL-BEARING HUB (2)

### **L=R** FRONT BELT TENSION ADJUSTMENT

Front diff **UPPER** position - tab in bottom notch - provides **more steering**, but **less front traction**

Recommended for **medium-high** traction tracks and technical tracks.

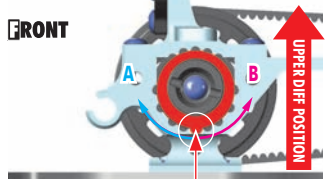

**INITIAL POSITION FOR CARPET/ASPHALT**  
Place tab in this **BOTTOM NOTCH**

**TO LOOSEN FRONT BELT:** Rotate both front nylon hubs in arrow direction **A**

**TO TIGHTEN FRONT BELT:** Rotate both front nylon hubs in arrow direction **B**

Front diff **LOWER** position - tab in top notch - provides **more front traction**, but makes the car **push on-power**.

Recommended for **low-traction** tracks.

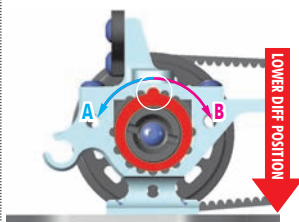

### **L=R** REAR BELT TENSION ADJUSTMENT

Rear diff **UPPER** position - tab in bottom notch - provides **more on-power steering**, but makes the rear slightly more loose.

Recommended for **medium-high** traction tracks.

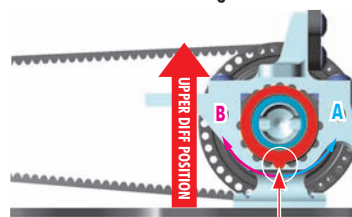

**INITIAL POSITION FOR CARPET/ASPHALT**  
Place tab in this **BOTTOM NOTCH**

**TO LOOSEN REAR BELT:** Rotate both rear nylon hubs in arrow direction **A**

**TO TIGHTEN REAR BELT:** Rotate both rear nylon hubs in arrow direction **B**

Rear diff **LOWER** position - tab in top notch - provides **more rear traction** (mainly on-power), makes the car **more stable in chicanes**, but makes the car **push on-power**.

Recommended for **low-medium** traction tracks.

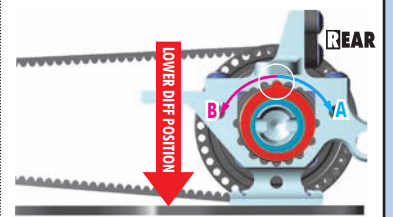

## 2. CENTRAL TRANSMISSION



902304  
SH M3x4



970050  
O 5x1



966081  
CH-CLIP 8

1.

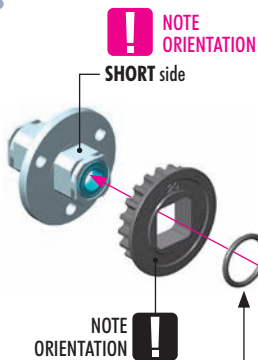

#966081 CH-CLIP 8 (10)  
INCLUDED IN THE LAST AID BAG

Another alternative to secure the pulley on the layshaft is to use the Clip which is included in the "Last Aid" Bag. To mount the clip on the layshaft, you have to use special Snap Ring Pliers.



Snap Ring Pliers

2.

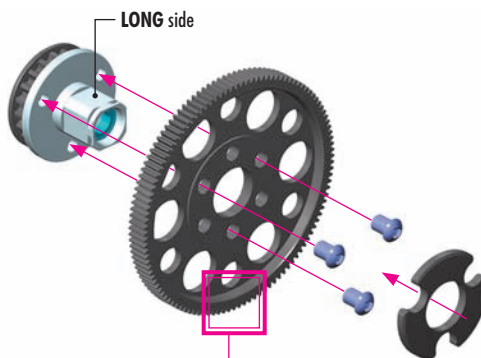

NOTE ORIENTATION



OFFSET SPUR GEARS 48P

#305772	72T	OPTION
#305776	76T	OPTION
#305778	78T	OPTION
#305779	79T	OPTION
#305781	81T	OPTION
#305784	84T	OPTION
#305784-0	84T	OPTION



OFFSET SPUR GEARS 64P

#305860	90T	OPTION
#305862	92T	OPTION
#305866	96T	OPTION
#305866-0	96T	OPTION
#305869	99T	OPTION
#305870	100T	OPTION
#305870-0	100T	OPTION
#305874	104T	OPTION
#305876	106T	OPTION
#305878	108T	OPTION
#305880	110T	INCLUDED
#305880-0	110T	OPTION
#305882	112T	OPTION
#305884	114T	OPTION

3.

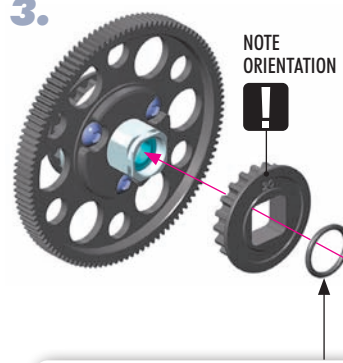

#966081 CH-CLIP 8 (10)  
INCLUDED IN THE LAST AID BAG

Another alternative to secure the pulley on the layshaft is to use the Clip which is included in the "Last Aid" Bag. To mount the clip on the layshaft, you have to use special Snap Ring Pliers.



Snap Ring Pliers

#305578-0  
FIXED PULLEY 20T  
GRAPHITE (2)



SET-UP BOOK

GEARING ADJUSTMENT

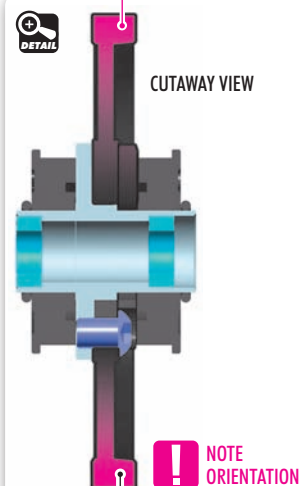

NOTE ORIENTATION



902305  
SH M3x5



903305  
SFH M3x5



903308  
SFH M3x8



962042  
S 4x6x0.1

1.

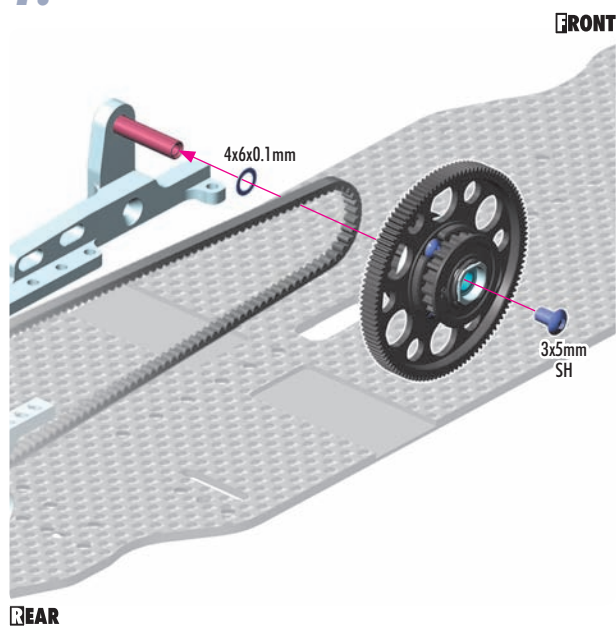

2.

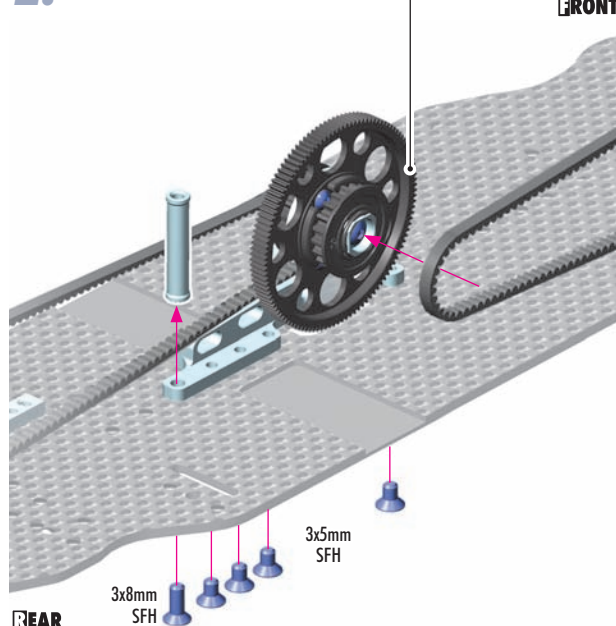

## 2. CENTRAL TRANSMISSION

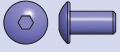

902306  
SH M3x6

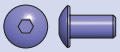
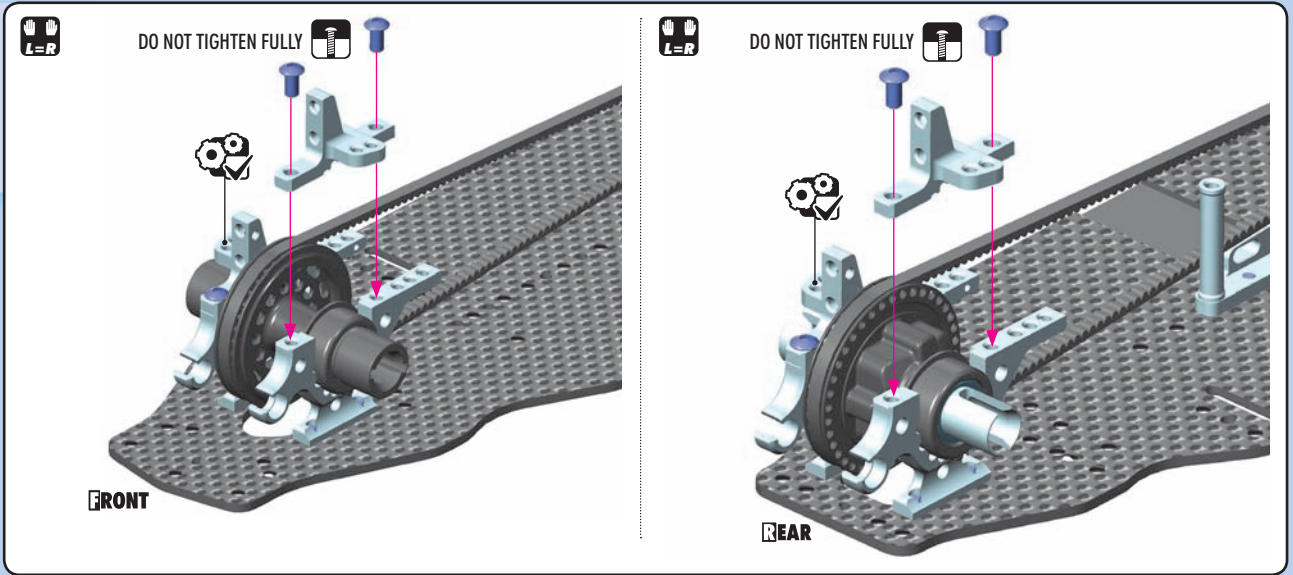

902306  
SH M3x6

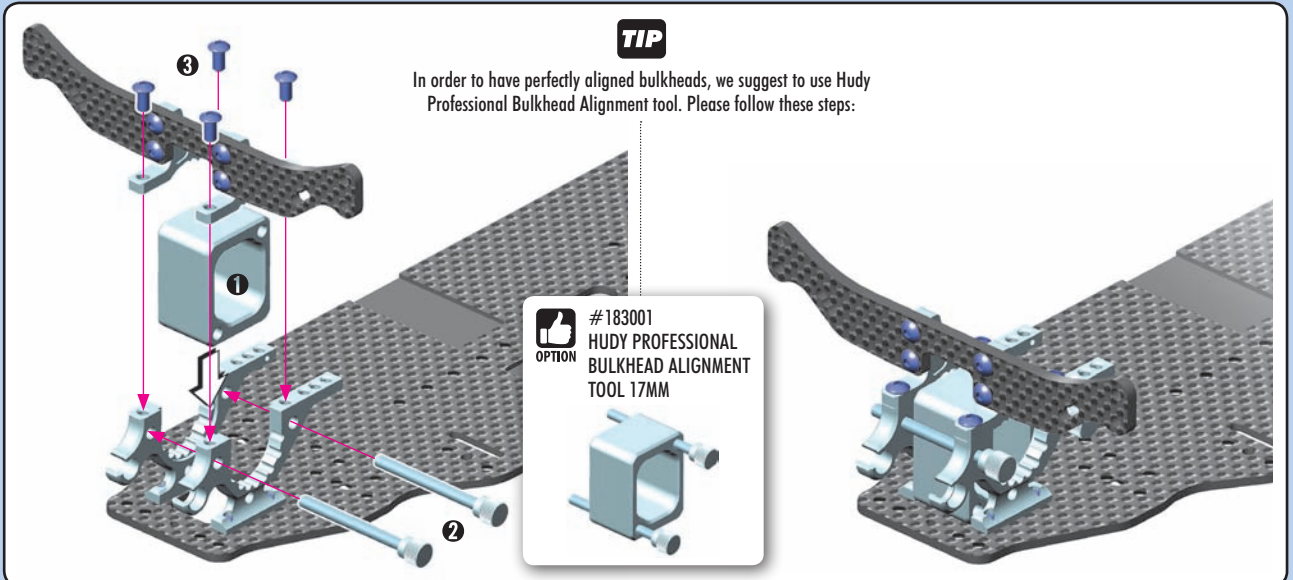
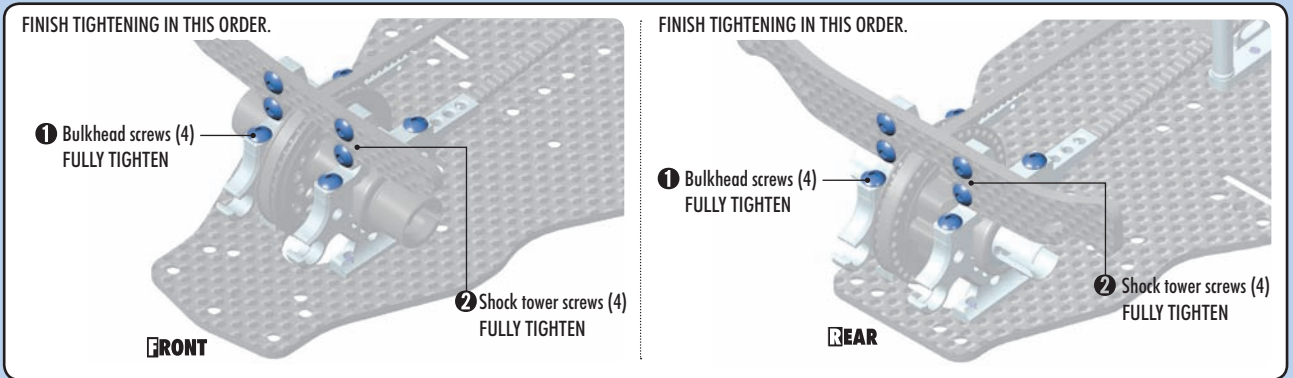
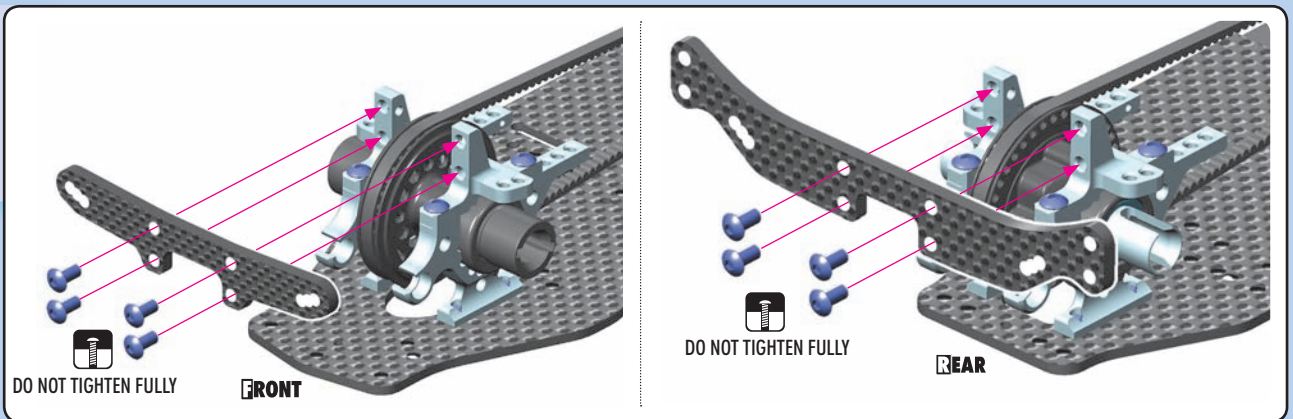

# 3. FRONT & REAR SUSPENSION

**#303731 ALU LOWER 2-PIECE SUSPENSION 0.25 ECCENTRIC HOLDER STAND**  
OPTION

**#307217 TITANIUM SUSPENSION PIVOT PIN (2)**  
OPTION

**FRONT ARMS - LONG**

#302173-H	HARD	RIGHT	OPTION
#302174-H	HARD	LEFT	OPTION
#302173-G	GRAPHITE	RIGHT	INCLUDED
#302174-G	GRAPHITE	LEFT	INCLUDED

**REAR ARMS - LONG**

#303173-H	HARD	RIGHT	OPTION
#303174-H	HARD	LEFT	OPTION
#303173-G	GRAPHITE	RIGHT	INCLUDED
#303174-G	GRAPHITE	LEFT	INCLUDED

- |            |   |  |
|------------|---|--|
| <b>BAG</b> | <p>302173 FRONT SUSPENSION ARM LONG RIGHT - GRAPHITE</p> <p>302174 FRONT SUSPENSION ARM LONG LEFT - GRAPHITE</p> <p>302713 T4'20 ALU FRONT LOWER 1-PIECE SUSPENSION HOLDER - FRONT - FF</p> <p>302723 T4'20 ALU FRONT LOWER 1-PIECE SUSPENSION HOLDER - REAR - FR</p> <p>303129 COMPOSITE SET OF WHEELBASE SHIMS (3x1MM; 1x2MM) (2)</p> <p>303173 REAR SUSPENSION ARM LONG RIGHT - GRAPHITE</p> <p>303174 REAR SUSPENSION ARM LONG LEFT - GRAPHITE</p> <p>303723 T4'20 ALU REAR LOWER 1-PIECE SUSPENSION HOLDER - REAR - RR</p> | <p>303730 T4'20 ALU REAR LOWER 2-PIECE SUSPENSION HOLDER - FRONT (1)</p> <p>307216 SUSPENSION PIVOT PIN (2)</p> <p>362315 ECCENTRIC BUSHING SET (2)</p> <p>901310 HEX SCREW SB M3x10 (10)</p> <p>901408 HEX SCREW SB M4x8 (10)</p> <p>903306 HEX SCREW SFH M3x6 (10)</p> |
|------------|---|--|

**2x** **L=R** **REAR ARMS**

901310 SB M3x10

901408 SB M4x8

**LEFT REAR ARM**

**REAR ARMS - LONG**

#303173-H	HARD	RIGHT	OPTION
#303174-H	HARD	LEFT	OPTION
#303173-G	GRAPHITE	RIGHT	INCLUDED
#303174-G	GRAPHITE	LEFT	INCLUDED

**REAR LEFT ARM**      **REAR RIGHT ARM**

2.3mm

**TOP**      **BOTTOM**

**2x** **L=R** **FRONT ARMS**

901310 SB M3x10

901408 SB M4x8

**FRONT RIGHT ARM**

**FRONT ARMS - LONG**

#302173-H	HARD	RIGHT	OPTION
#302174-H	HARD	LEFT	OPTION
#302173-G	GRAPHITE	RIGHT	INCLUDED
#302174-G	GRAPHITE	LEFT	INCLUDED

**FRONT RIGHT ARM**      **FRONT LEFT ARM**

2.2mm

**TOP**      **BOTTOM**

# 3. FRONT & REAR SUSPENSION

IO

303129  
SHIM 3x6x1



903306  
SFH M3x6

## REAR SUSPENSION



It is extremely important that the arms move freely on the pivot pins. If they do not, use the Arm Reamer (3.0mm) to slightly resize the holes in the arms.

#107633 HUDY Arm Reamer 3.0mm



**#303731 ALU LOWER 2-PIECE SUSPENSION 0.25 ECCENTRIC HOLDER STAND**



REAR

NOTE ORIENTATION

RIGHT

Marked "RR"

NOTE ORIENTATION

COMPOSITE ECCENTRIC BUSHINGS  
INITIAL SETTING



1mm

NOTE ORIENTATION

LEFT

1mm

COMPOSITE ECCENTRIC BUSHINGS  
INITIAL SETTING



INITIAL SETTING

REAR



COMPOSITE ECCENTRIC BUSHINGS



Do not use INNER positions. ● Available positions



**#307217 TITANIUM SUSPENSION PIVOT PIN (2)**



SET-UP BOOK

TOE-IN  
TRACK-WIDTH  
WHEELBASE  
ROLL CENTER  
ANTI-SQUAT  
PRO-SQUAT

### ECCENTRIC BUSHINGS HAVE TWO DIFFERENT OFFSETS FROM THE CENTER



Middle position = 0.5 mm or 0.5° from center



Outer position = 1 mm or 1° from center

The XRAY rear alu lower suspension holders provide even greater range of adjustment for the rear suspension. Using different combinations of eccentric bushings, fine adjustment of rear squat, rear toe-in, rear roll center, and rear track-width can be obtained. For more information about the influence of rear squat, rear toe-in, rear roll center and rear track-width on car handling, please refer to HUDY Set-up Book (#209100).

## FRONT SUSPENSION

FRONT

Marked "FR"

NOTE ORIENTATION

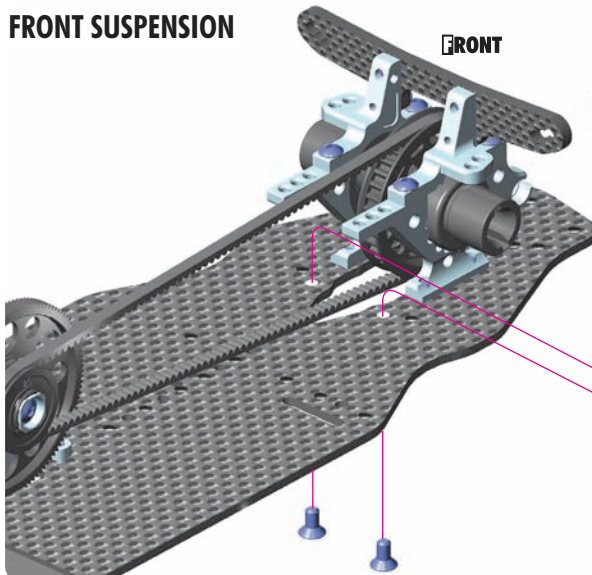

903306  
SFH M3x6

# 3. FRONT & REAR SUSPENSION

10

303129  
SHIM 3x6x1



903306  
SFH M3x6

## FRONT SUSPENSION

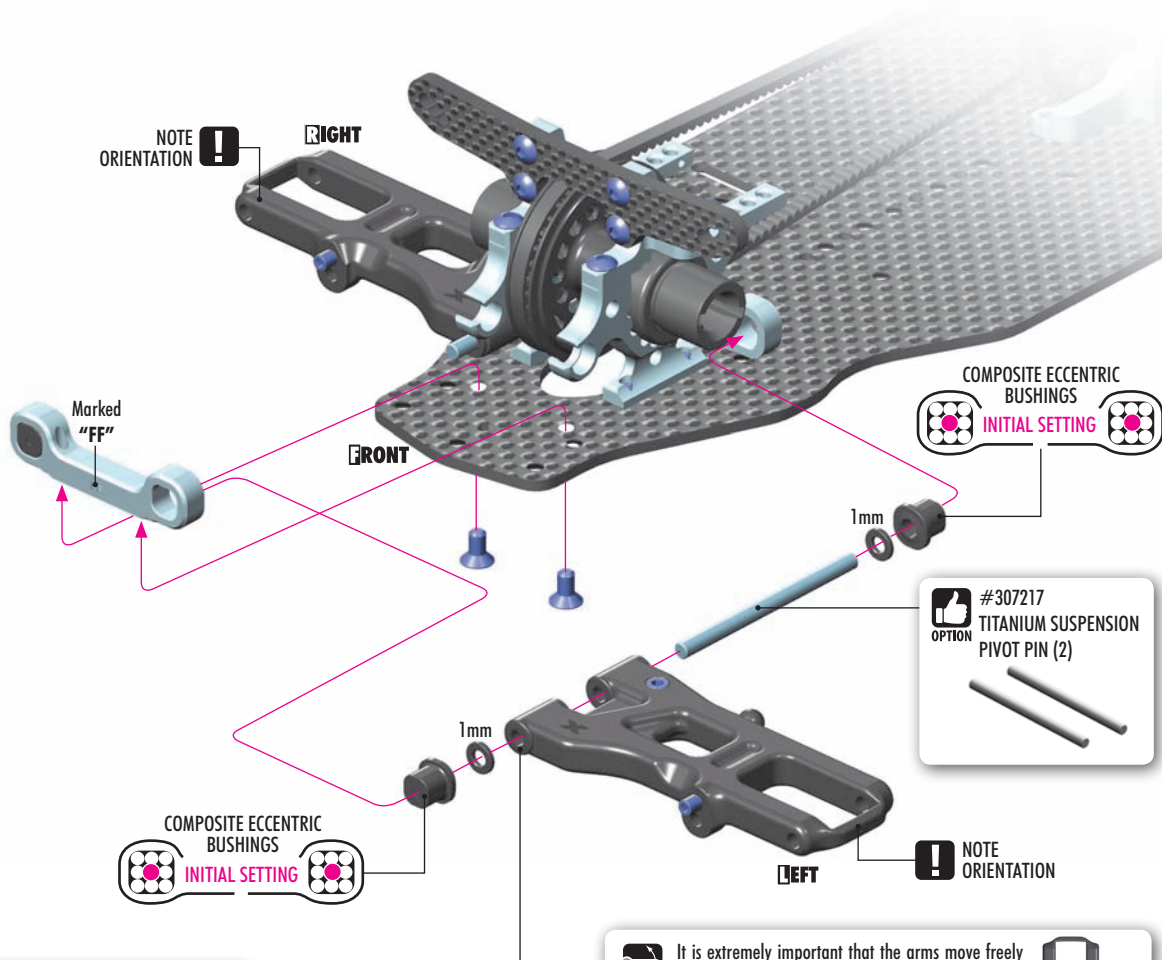

It is extremely important that the arms move freely on the pivot pins. If they do not, use the Arm Reamer (3.0mm) to slightly resize the holes in the arms.

#107633 HUDY Arm Reamer 3.0mm

All possible mounting alternatives of eccentric bushings

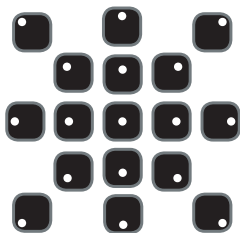

ECCENTRIC BUSHINGS HAVE TWO DIFFERENT OFFSETS FROM THE CENTER.

- Middle position = 0.5 mm or 0.5° from center
- Outer position = 1mm or 1° from center

The XRAY front alu lower suspension holders provide even greater range of adjustment for the front suspension. Using different combinations of eccentric bushings, fine adjustment of front anti-squat, front kick-up, front toe-in, front roll center, and front track-width can be obtained. For more information about the influence of front anti-dive, front kick-up, front toe-in, front roll center and front track-width on car handling, please refer to HUDY Set-up Book.

**SET-UP BOOK**

TOE-IN  
TRACK-WIDTH  
WHEELBASE  
ROLL CENTER  
ANTI-DIVE  
KICK-UP

# 4. STEERING



#301061  
T4'20 GRAPHITE UPPER DECK 1.6MM



#302548  
ALU STEERING PLATE 8MM FOR DUAL SERVO SAVER

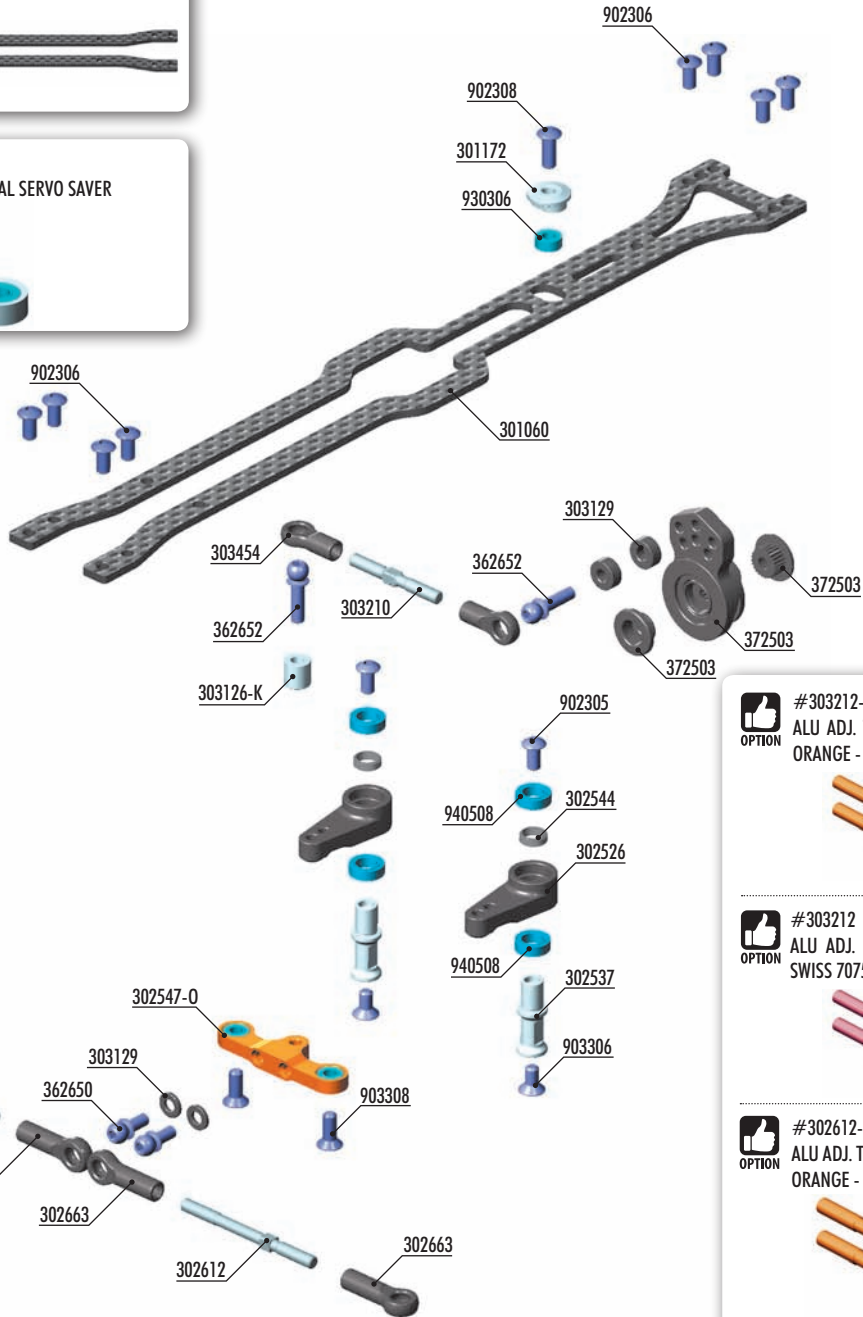

#302525  
ALU DUAL-SERVO SAVER ARM



#303071  
BELT TENSIONER



**BAG**

**04**

- 301060 T4'20 GRAPHITE UPPER DECK 2.0MM
- 301172 ALU UPPER DECK COLLAR FOR FLEX ELIMINATION
- 302526 COMPOSITE DUAL SERVO SAVER
- 302537 T4'20 ALU STEERING POST FOR DUAL SERVO SAVER (2)
- 302544 ALU SHIM FOR RADIAL PLAY ADJUSTMENT OF STEERING ARM (2)
- 302547-0 T4 ALU STEERING PLATE 8.5MM FOR DUAL-SERVO SAVER - ORANGE
- 302612 ALU ADJ. TURNBUCKLE M3 L/R 39 MM - SWISS 7075 T6 (2)
- 302663 COMPOSITE BALL JOINT 5 MM - OPEN - V2 (8)
- 303126-K ALU SHIM 3x6x5.0MM - BLACK (10)
- 303129 COMPOSITE SET OF SHIMS (3x1MM; 1x2MM) (2)
- 303210 REAR TURNBUCKLE L/R 26 MM - HUDY SPRING STEEL (2)
- 303454 BALL JOINT 4.9MM - OPEN (4)

- 362650 BALL END 4.9MM WITH THREAD 6MM (2)
- 362652 BALL END 4.9MM WITH THREAD 10MM (2)
- 372503 COMPOSITE SERVO SAVER - X-STIFF - SET - V2

- 902305 HEX SCREW SH M3x5 (10)
- 902306 HEX SCREW SH M3x6 (10)
- 902308 HEX SCREW SH M3x8 (10)
- 903306 HEX SCREW SFH M3x6 (10)
- 903308 HEX SCREW SFH M3x8 (10)
- 930306 BALL-BEARING 3x6x2.5 STEEL-SEALED - OILED (2)
- 940508 BALL-BEARING 5x8x2.5 RUBBER-SEALED - OILED (2)



#303212-0  
ALU ADJ. TURNBUCKLE L/R 26mm - ORANGE - SWISS 7075 T6 (2)



#303212  
ALU ADJ. TURNBUCKLE L/R 26mm - SWISS 7075 T6 (2)



#302612-0  
ALU ADJ. TURNBUCKLE M3 L/R 39mm ORANGE - SWISS 7075 T6 (2)



#302610  
ADJ. TURNBUCKLE L/R 40mm HUDY SPRING STEEL™ (2)





**2x STEERING LINKS**

LEFT THREAD      RIGHT THREAD

**2x** L-R

65.4mm

**OPTION** #302612-0  
ALU ADJ. TURNBUCKLE M3  
L/R 39mm ORANGE - SWISS  
7075 T6 (2)

**OPTION** #302610  
ADJ. TURNBUCKLE L/R 40mm  
HUDY SPRING STEEL (2)

**SERVO LINK**  
Adjust servo link to fit your servo

LEFT THREAD      RIGHT THREAD

approximately 47mm

- 903308  
SFH M3x8
- 930306  
BB 3x6x2.5
- 940508  
BB 5x8x2.5

BEARING OIL  
(HUDY #106230)

5x8x2.5mm

3x6x2.5mm

**NOTE ORIENTATION**

**!** **!**

Tighten the screws gently but fully, and then loosen 1/3 turn so the composite dual-servo saver moves freely.

- 1 tighten fully
- 2 loosen 1/3 ccw
- 3 check free movement

**1/3**  
(120° CCW)

**OPTION** #302548  
ALU STEERING PLATE 8MM FOR DUAL SERVO SAVER

Optional 8mm steering plate reduces steering response and increases cornering speed. Recommended for big open tracks, but also on technical tracks with many chicanes as it decreases over-steering and increases stability of the car in chicanes.

**FREE MOVEMENT** **!** When using 8mm steering plate, remove a bit of material from the ball joints so they do not touch each other.

**OPTION** #302525  
ALU DUAL SERVO SAVER ARM

We recommend using the aluminum dual-servo saver arms when better steering response is needed. Also recommended for asphalt tracks.

**10**  
303129  
SHIM 3x6x1

**2x** L-R

**NOTE ORIENTATION** **!**

6mm THREAD

**INITIAL SETTING** (1mm shim)

**NOTE ORIENTATION** **!**

**TIP** Install the pivot balls with Professional Multi Tool (HUDY #183011)

**TIP**

To change Ackermann angle, use 2 identical shims (of same thickness) between the alu steering plate and ball ends.

1mm 1mm 1mm 2mm

# 4. STEERING



303129  
SHIM 3x6x2



303126-K  
SHIM 3x6x5

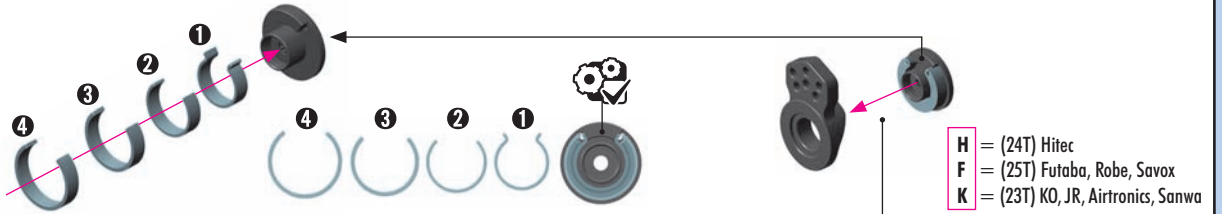

When using optional aluminum steering arms, we suggest using optional shims #303134-K (3x7.5x1.5mm) + #303123-K (3x6x2mm) when you want to eliminate steering lock in high-traction conditions.

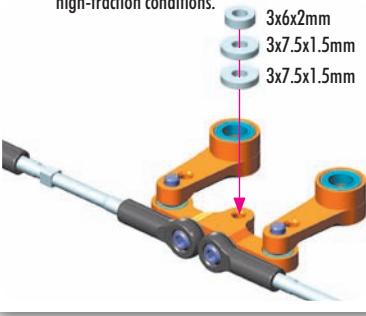

3x6x2mm  
3x7.5x1.5mm  
3x7.5x1.5mm

**H** = (24T) Hitec  
**F** = (25T) Futaba, Robe, Savox  
**K** = (23T) KO, JR, Airtronics, Sanwa

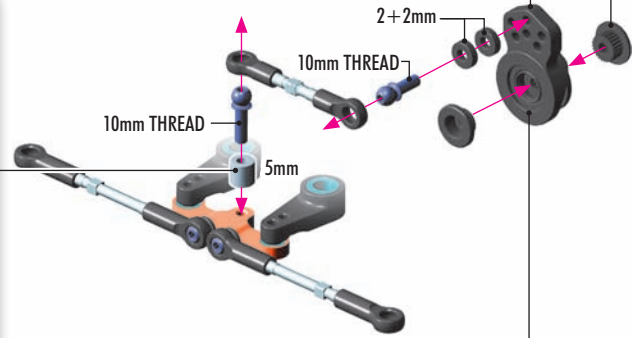

For more in-corner steering and better steering response, aluminum servo horns may be used.



ALU SERVO HORNS - OFFSET	
#293491	KO, Sanwa - 23T
#293492	Hitec - 24T
#293493	Futaba - 25T
CLAMP ALU SERVO HORNS - OFFSET	
#293401	KO, Sanwa - 23T
#293402	Hitec - 24T
#293403	Futaba - 25T



HUDY ALU SERVO HORNS	
#293497	KO, Sanwa - 23T
#293498	Hitec - 24T
#293499	Futaba - 25T
HUDY CLAMP ALU SERVO HORNS	
#293404	KO, Sanwa - 23T
#293405	Hitec - 24T
#293406	Futaba - 25T



HUDY ALU SERVO HORNS	
#293501	KO, Sanwa - 23T
#293502	Hitec - 24T
#293503	Futaba - 25T
HUDY CLAMP ALU SERVO HORNS	
#293407	KO, Sanwa - 23T
#293408	Hitec - 24T
#293409	Futaba - 25T



**IMPORTANT!** When than aluminum horn is used, the steering servo saver is not used. This increases the risk of breaking the servo in serious crashes.



902305  
SH M3x5



903306  
SFH M3x6

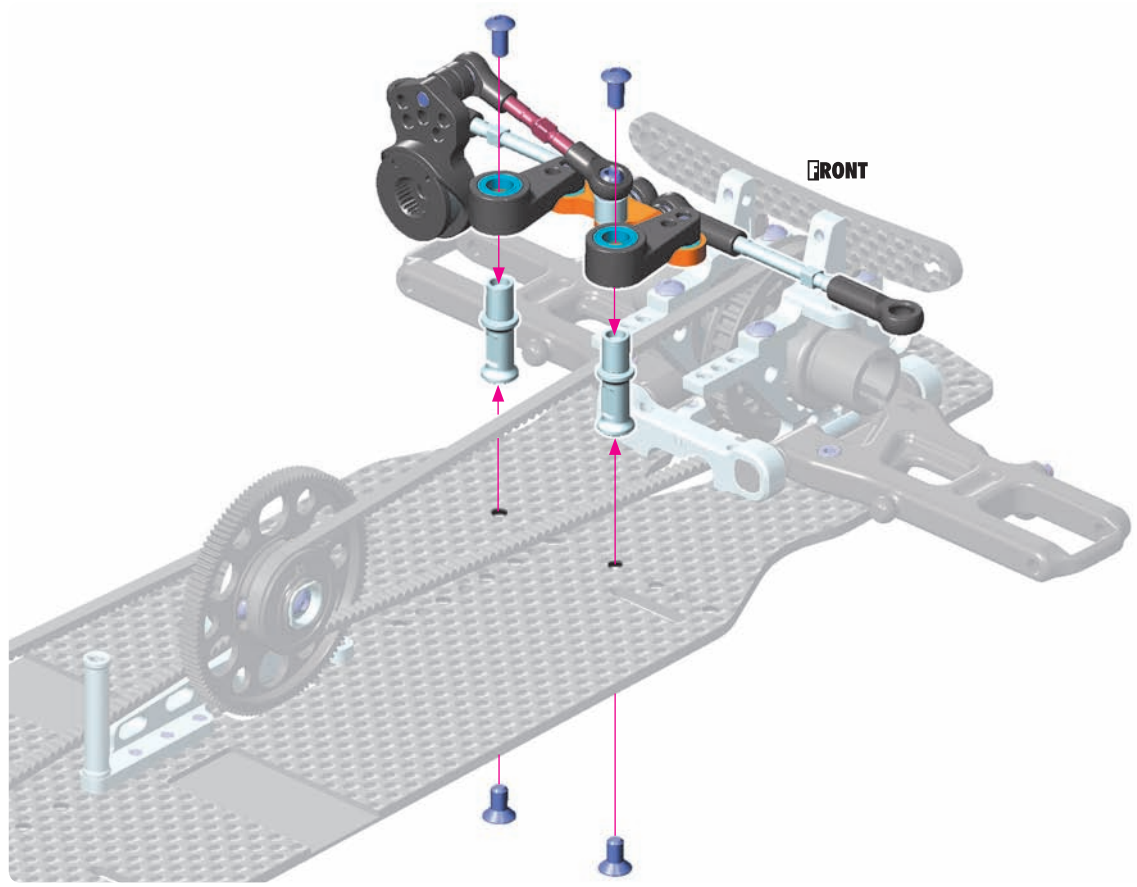

FRONT

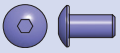

902306  
SH M3x6

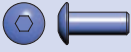

902308  
SH M3x8



930306  
BB 3x6x2.5

## TOP DECK FLEX SETTINGS

The new feature of the top deck is the flex setting adjustment. There are three different flex setting alternatives.

**SOFT**



Post is not connected to the top deck. This allows maximum flex setting and provides maximum steering characteristics. However, the car is less stable on-power.

**MEDIUM**



Post is connected to the top deck via ball bearing. This allows the top deck to flex to the sides but not to the front/rear. This setting eliminates a bit of steering but improves stability.

**STIFF**



Post is connected to the top deck via aluminum bushing. This setting provides maximum stability as it stiffens the entire car and eliminates flex to sides and front/rear.

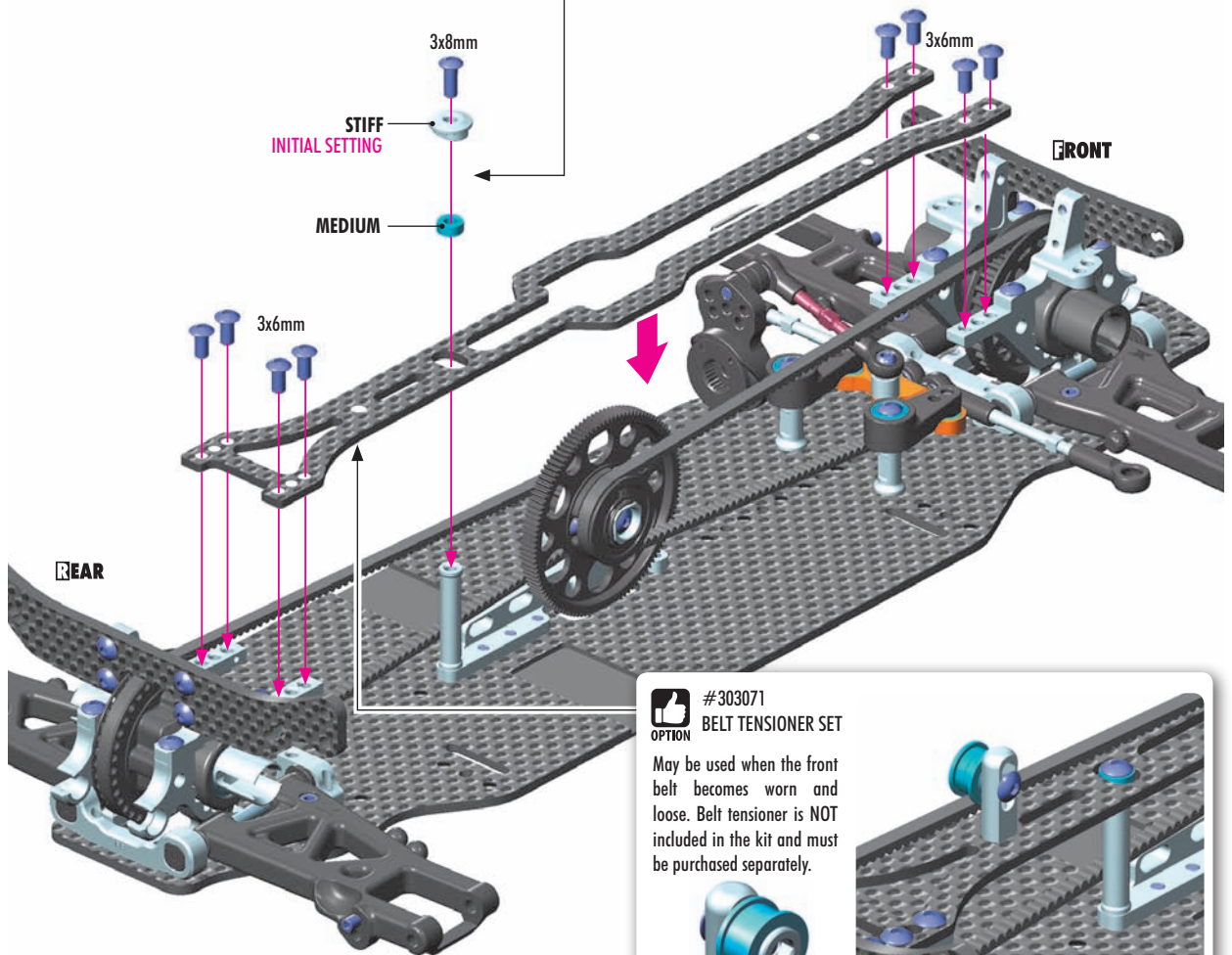

### #303071 BELT TENSIONER SET

May be used when the front belt becomes worn and loose. Belt tensioner is NOT included in the kit and must be purchased separately.

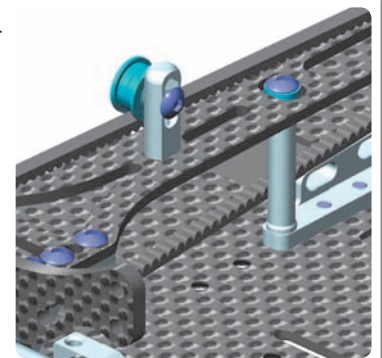
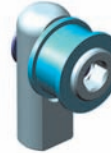

### #301061 T4'20 GRAPHITE TOP DECK 1.6MM



We recommend using optional 1.6mm top deck for super-low traction conditions or in combination with aluminum chassis as it provides more overall traction and steering.



CHASSIS FLEX SETTING  
TOP DECK SETTING

# 5. FRONT & REAR TRANSMISSION



## DRIVE SHAFTS

#305323	50MM - STEEL
#305324	52MM - STEEL
#305326	52MM - ALU
#305332	52MM - ECS
#305333	50MM - ECS



## STEERING BLOCKS

#302252	MEDIUM	OPTION
#302253	HARD	INCLUDED
#302254	GRAPHITE	OPTION
#302256	ALU	OPTION



#305242  
DRIVE SHAFT REPLACEMENT CAP  
3.5MM - ORANGE - STRONG (4)



#307222 TITANIUM FRONT ARM PIVOT PIN (2)  
#307322 TITANIUM REAR ARM PIVOT PIN (2)



#303212-0  
ALU TURNBUCKLE L/R 26mm  
ORANGE - SWISS 7075 T6 (2)



#303210  
TURNBUCKLE M3 L/R 26mm  
HUDY SPRING STEEL™ (2)



#309002  
SET OF CERAMIC  
BALL-BEARINGS (14)



## UPRIGHTS

#303351	1° - R	MEDIUM	(2-HOLE)
#303352	0° - R/L	MEDIUM	(2-HOLE)
#303353	1° - R	HARD	(2-HOLE)
#303354	0° - R/L	HARD	(2-HOLE)
#303360	0° - R/L	GRAPHITE	(2-HOLE)
#303361	1° - L	MEDIUM	(2-HOLE)
#303362	0° - R/L	MEDIUM	(1-HOLE)
#303363	1° - L	HARD	(2-HOLE)
#303364	0° - R/L	HARD	(1-HOLE)
#303358	ALU 1° - R/L		(4-HOLE)
#303359	ALU 2° - R/L		(4-HOLE)

## BAG



- 302253 COMPOSITE STEERING BLOCK - HARD
- 302291 STEEL STEERING BUSHING (2+2)
- 302363 COMPOSITE C-HUB RIGHT - 4° DEG. - MEDIUM - V2
- 302364 COMPOSITE C-HUB LEFT - 4° DEG. - MEDIUM - V2
- 302663 COMPOSITE BALL JOINT 4.9MM - OPEN - V2 (8)
- 302814 T4'20 ANTI-ROLL BAR FOR BALL-BEARINGS - FRONT 1.4 MM
- 303122-K ALU SHIM 3x6x1.0MM - BLACK (10)
- 303123-K ALU SHIM 3x6x2.0MM - BLACK (10)
- 303127-K ALU SHIM 3x6x4.0MM - BLACK (10)
- 303212 ALU ADJ. TURNBUCKLE M3 L/R 26 MM - SWISS 7075 T6 (2)
- 303354 COMPOSITE UPRIGHT 0° OUTBOARD TOE-IN - HARD
- 303433 ALU ANTI-ROLL BAR BUSHING - 6MM (2)
- 303455 COMPOSITE ANTI-ROLL BAR BALL JOINT (4)
- 303457 BALL JOINT 4.9MM - EXTRA SHORT OPEN (4)
- 303803 ANTI-ROLL BAR FOR BALL BEARINGS - REAR 1.3 MM
- 305231 DRIVE SHAFT COUPLING - HUDY SPRING STEEL™
- 305231 DRIVE SHAFT REPLACEMENT CAP 3.5 MM (4)
- 305221 ECS (ES) DRIVE SHAFT 51MM FOR 2MM PIN - HUDY SPRING STEEL™ (1)
- 305253 ECS DRIVE SHAFT COUPLING FOR 2MM PIN - HUDY SPRING STEEL™
- 305254 ECS (ES) DRIVE SHAFT CASE FOR 2MM PIN - HUDY SPRING STEEL™
- 305328 ALU DRIVE SHAFT SWISS 7075 T6 - HARDCOATED - 50MM

- 305334 ECS ES (ES) DRIVE SHAFT 51MM - HUDY SPRING STEEL™ - SET
- 305341 DRIVE AXLE - LIGHTWEIGHT - HUDY SPRING STEEL™
- 305346 ECS DRIVE AXLE FOR 2MM PIN - HUDY SPRING STEEL™
- 305350-K ALU WHEEL HUB - BLACK (2)
- 305392 DRIVE SHAFT PIN 2 x 10 WITH FLAT SPOT (2)
- 305394 ECS DRIVE SHAFT PIN 2 x 9 WITH FLAT SPOT (2)
- 307221 FRONT ARM PIVOT PIN (2)
- 307321 REAR ARM PIVOT PIN (2)
- 362648 BALL END 4.9MM WITH THREAD 4MM (2)
- 362649 BALL END 4.9MM WITH THREAD 5MM (2)
- 362651 BALL END 4.9MM WITH THREAD 8MM (2)
- 362652 BALL END 4.9MM WITH THREAD 10MM (2)
- 901302 HEX SCREW SB M3x2.5 (10)
- 901304 HEX SCREW SB M3x4 (10)
- 902205 HEX SCREW SH M2x5 (10)
- 902310 HEX SCREW SH M3x10 (10)
- 930306 BALL-BEARING 3x6x2.5 STEEL-SEALED - OILED (2)
- 940510 BALL-BEARING 5x10x4 RUBBER SEALED - OIL (2)
- 980210 PIN 2x10 (10)

# 5. FRONT & REAR TRANSMISSION



901302  
SB M3x2.5



305392  
P 2x10



305394  
P 2x9

## 2x REAR TRANSMISSION

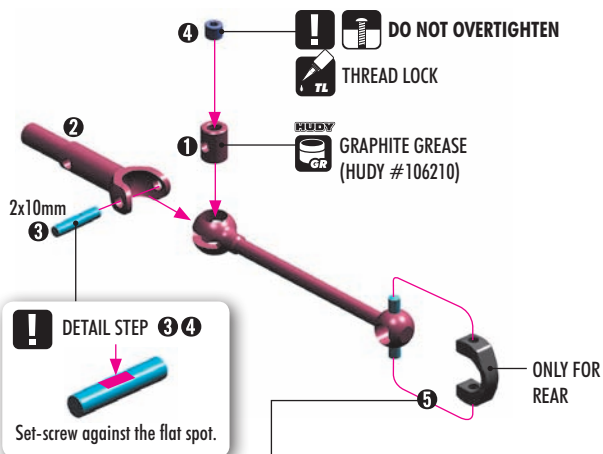

### DETAIL STEP 3 4

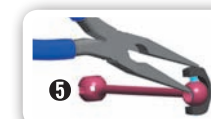

**TIP** For easy installation of the #305241 plastic caps, use pliers as shown.

**OPTION** #305242  
DRIVE SHAFT REPLACEMENT CAP  
3.5MM ORANGE - STRONG (4)



## 2x FRONT TRANSMISSION

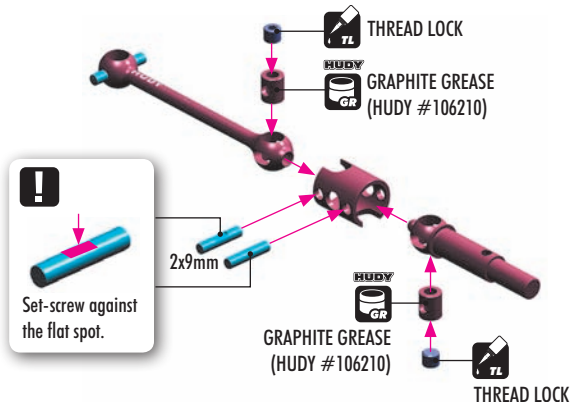

### ECS DRIVE SHAFTS

ECS drive shafts are available in 51mm length in kit, or optional 50mm & 52mm lengths. The ECS drive shafts were developed to decrease front wheel vibration when racing with a solid front axle, thus providing a much smoother and quieter ride and increased steering.



### DRIVE SHAFTS

#305323	50MM - STEEL
#305324	52MM - STEEL
#305326	52MM - ALU
#305332	52MM - ECS
#305333	50MM - ECS



Longer drive shafts (52mm) make the car easier to drive because they give more traction and better stability, mainly in chicanes. However, the car will understeer more than with shorter (50mm) shafts which give a lot of steering and make the car more aggressive. Both left & right shafts should ALWAYS be the same length at one end of the car (front or rear).

52mm shafts are recommended for **carpet high-traction** tracks.  
51mm shafts are recommended for **carpet** tracks and **large asphalt** tracks.  
50mm shafts are recommended for **low-traction** or **tight asphalt** tracks.

The new 51mm drive shafts which are included in the kit are the best compromise between 50 and 52mm lengths.



902205  
SH M2x5



940510  
BB 5x10x4



980210  
P 2x10

## L-R REAR TRANSMISSION

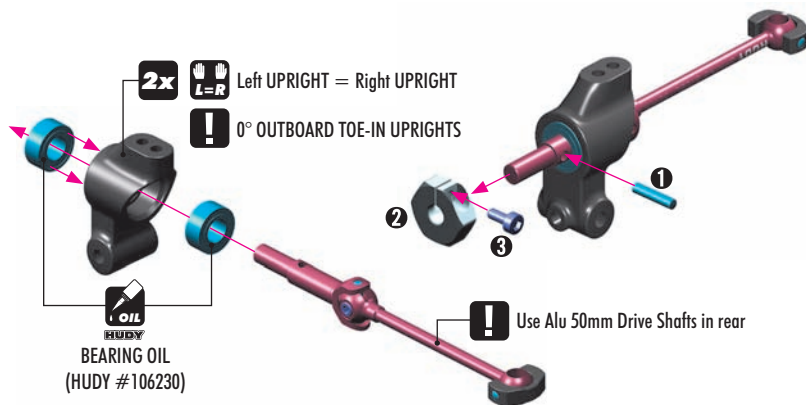

**OIL**  
BEARING OIL  
(HUDY #106230)



### UPRIGHTS

<b>OPTION</b>	#303351	1° - R MEDIUM	(2-HOLE)
	#303352	0° - R/L MEDIUM	(2-HOLE)
	#303353	1° - R HARD	(2-HOLE)
<b>INCLUDED</b>	#303354	0° - R/L HARD	(2-HOLE)
	#303360	0° - R/L GRAPHITE	(2-HOLE)
	#303361	1° - L MEDIUM	(2-HOLE)
	#303362	0° - R/L MEDIUM	(1-HOLE)
	#303363	1° - L HARD	(2-HOLE)
	#303364	0° - R/L HARD	(1-HOLE)
	#303358	ALU 1° - R/L	(4-HOLE)
	#303359	ALU 2° - R/L	(4-HOLE)



REAR TOE-IN  
TRACK-WIDTH

# 5. FRONT & REAR TRANSMISSION



902205  
SH M2x5

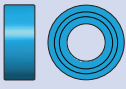

940510  
BB 5x10x4



980210  
P 2x10



REAR TOE-IN  
TRACK-WIDTH

## 2x FRONT TRANSMISSION

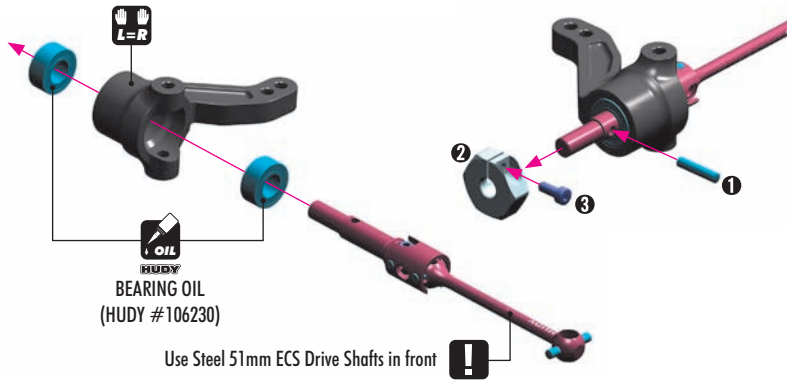

### ALU OFFSET WHEEL HUBS

#305350-K	0mm	INCLUDED
#305351	-0.75mm	OPTION
#305352	+0.75mm	OPTION
#305353	+1.5mm	OPTION



### STEERING BLOCKS

#302252	MEDIUM	OPTION
#302253	HARD	INCLUDED
#302254	GRAPHITE	OPTION
#302256	ALU	OPTION

## 2x FRONT TRANSMISSION

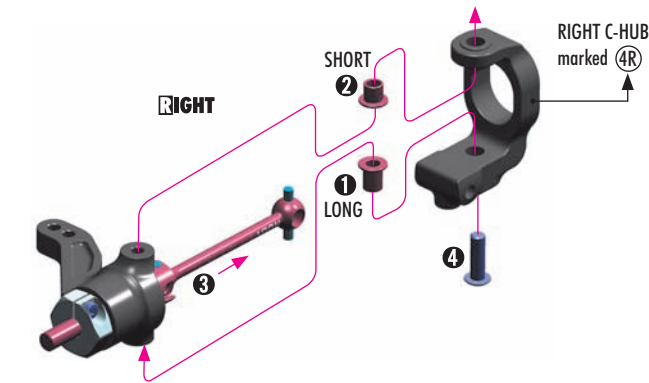

### C-HUBS FRONT TRANSMISSION

#302335	2° - RIGHT	ALU	OPTION
#302336	2° - LEFT	ALU	OPTION
#302337	4° - RIGHT	ALU	OPTION
#302338	4° - LEFT	ALU	OPTION
#302339	6° - RIGHT	ALU	OPTION
#302340	6° - LEFT	ALU	OPTION
#302361	2° - RIGHT	MEDIUM	OPTION
#302362	2° - LEFT	MEDIUM	OPTION
#302363	4° - RIGHT	MEDIUM	INCLUDED
#302364	4° - LEFT	MEDIUM	INCLUDED
#302365	6° - RIGHT	MEDIUM	OPTION
#302366	6° - LEFT	MEDIUM	OPTION
#302371	2° - RIGHT	HARD	OPTION
#302372	2° - LEFT	HARD	OPTION
#302373	4° - RIGHT	HARD	OPTION
#302374	4° - LEFT	HARD	OPTION
#302375	6° - RIGHT	HARD	OPTION
#302376	6° - LEFT	HARD	OPTION
#302383	4° - RIGHT	GRAPHITE	OPTION
#302384	4° - LEFT	GRAPHITE	OPTION



CASTER ADJUSTMENT

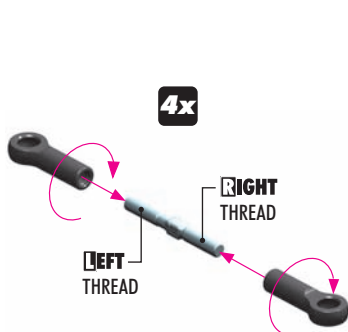

### FRONT



FRONT LEFT = FRONT RIGHT

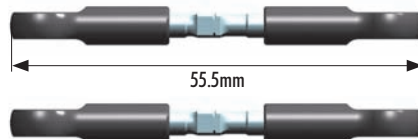

#303212-0  
ALU TURNBUCKLE L/R 26mm  
ORANGE - SWISS 7075 T6 (2)



### REAR



REAR LEFT = REAR RIGHT

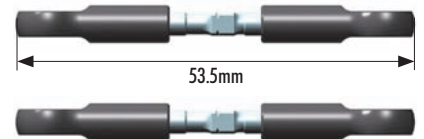

#303210  
TURNBUCKLE M3 L/R 26mm  
HUDY SPRING STEEL™ (2)



CAMBER ADJUSTMENT

# 5. FRONT & REAR TRANSMISSION



303122-K  
SHIM 3x6x1



303127-K  
SHIM 3x6x4



901304  
SB M3x4

## REAR SUSPENSION

The information about the optional Active rear suspension is at the end of the manual.

**OPTION** 1-HOLE REAR UPRIGHTS (See page 21)

An optional 1-hole rear upright is available for fine tuning. This optional upright may be used on high-traction tracks or tracks with long sweepers, since the position of the center hole will allow faster driving through those corners because of better cornering speed.

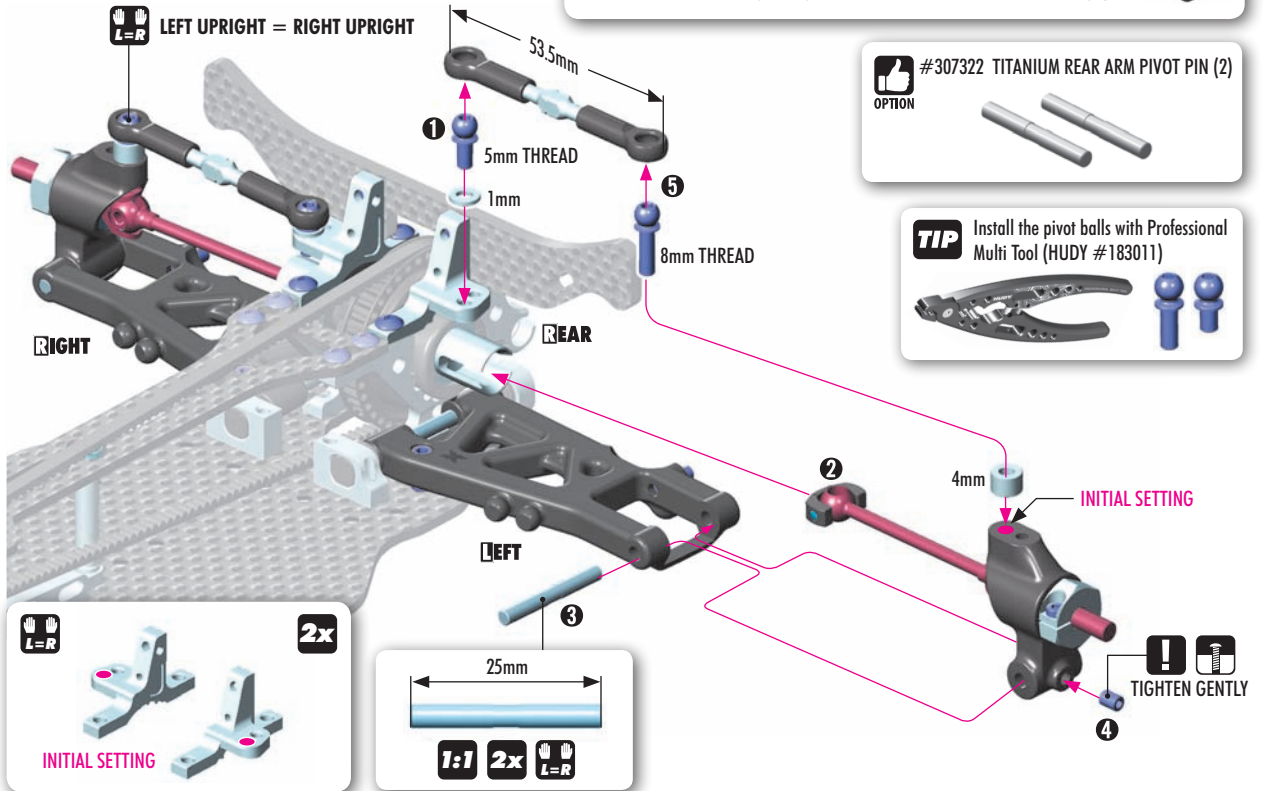

## FRONT SUSPENSION

**2x** **L=R**



303123-K  
SHIM 3x6x2



901304  
SB M3x4

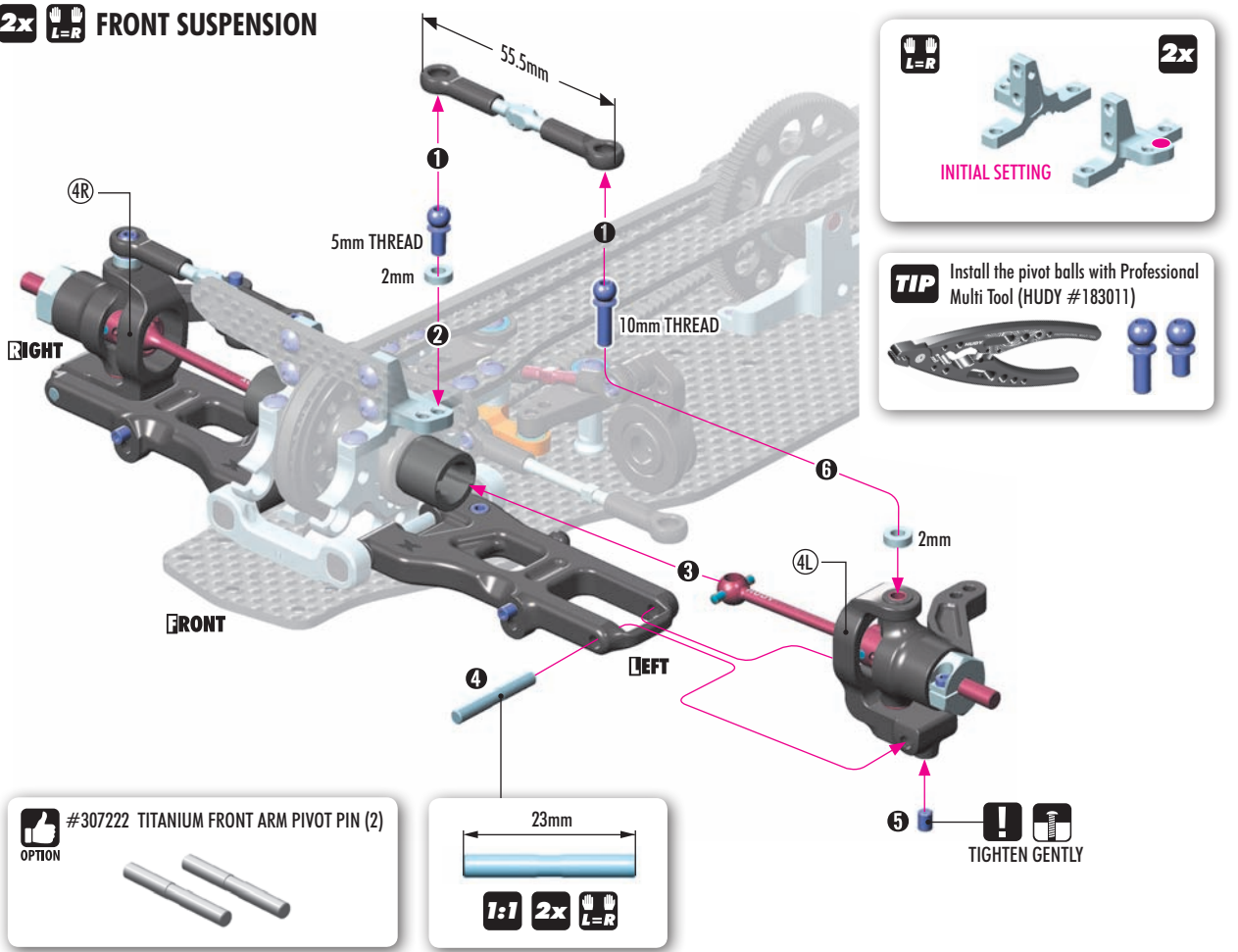

# 5. FRONT & REAR TRANSMISSION

**2x**  **FRONT**

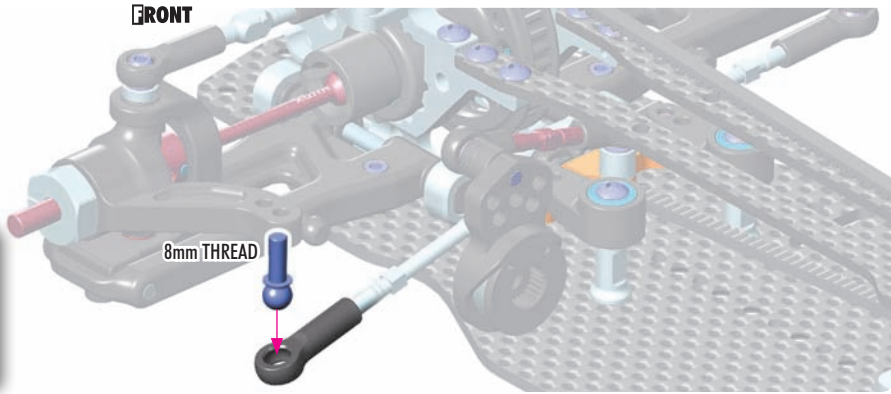

**TIP** Install the pivot balls with Professional Multi Tool (HUDY #183011)



8mm THREAD

**L=R** **FRONT TRANSMISSION**

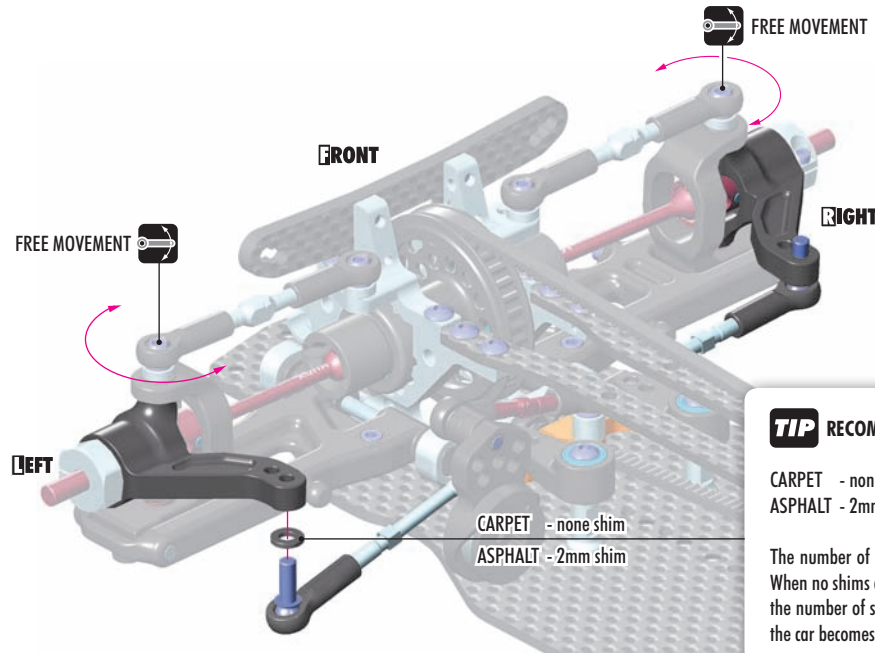

**INITIAL SETTING**



**TIP** RECOMMENDED BUMPSTEER SETTINGS:

CARPET - none shim  
 ASPHALT - 2mm thick shim

The number of shims changes the angles of the steering linkage. When no shims are used, the car is easy to drive into the corner. As the number of shims is increased, in-corner steering increases but the car becomes more difficult to drive.



**4x**  **4x**

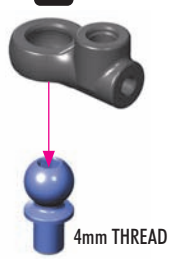

**TIP** Install the pivot balls with Professional Multi Tool (HUDY #183011)



4mm THREAD

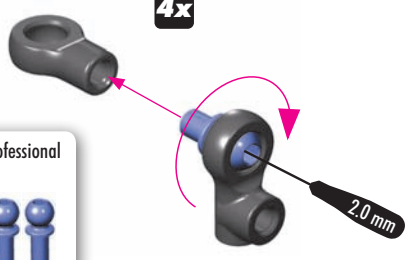

2.0 mm

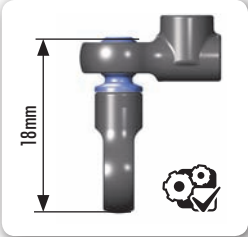

18mm



**2x**

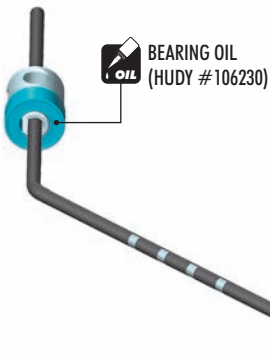

**BEARING OIL** (HUDY #106230)

REAR ANTI-ROLL BARS	
<b>OPTION</b>	#303801 REAR 1.1mm
	#303802 REAR 1.2mm
<b>INCLUDED</b>	#303803 REAR 1.3mm
	#303804 REAR 1.4mm
	#303805 REAR 1.5mm
	#303806 REAR 1.6mm

FRONT ANTI-ROLL BARS	
<b>OPTION</b>	#302812 FRONT 1.2mm
	#302813 FRONT 1.3mm
<b>INCLUDED</b>	#302814 FRONT 1.4mm
	#302815 FRONT 1.5mm

**BEARING OIL** (HUDY #106230)

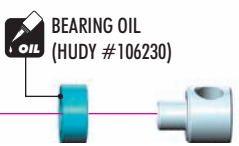



# 5. FRONT & REAR TRANSMISSION

## ! FRONT ANTI-ROLL BAR

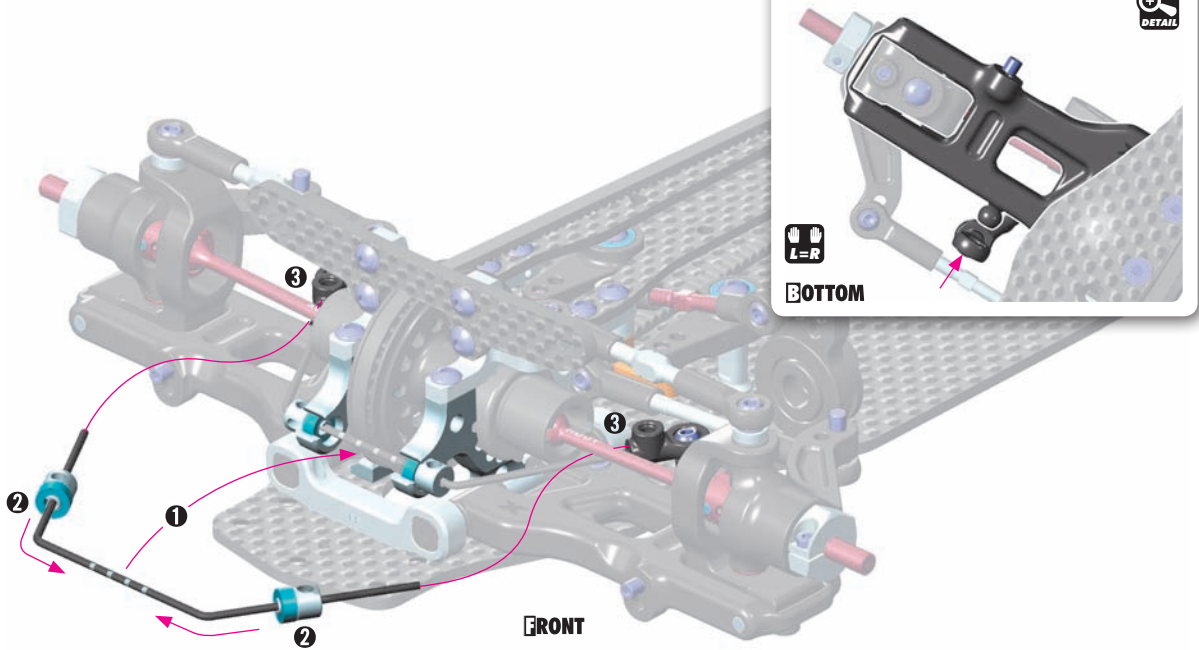

## ! FRONT ANTI-ROLL BAR

901302  
SB M3x2.5

901304  
SB M3x4

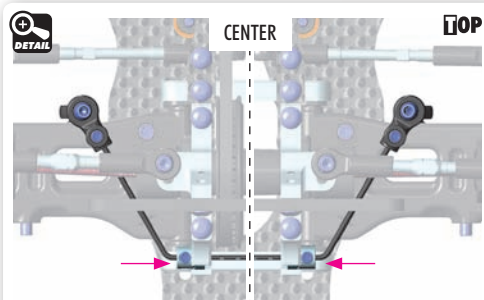
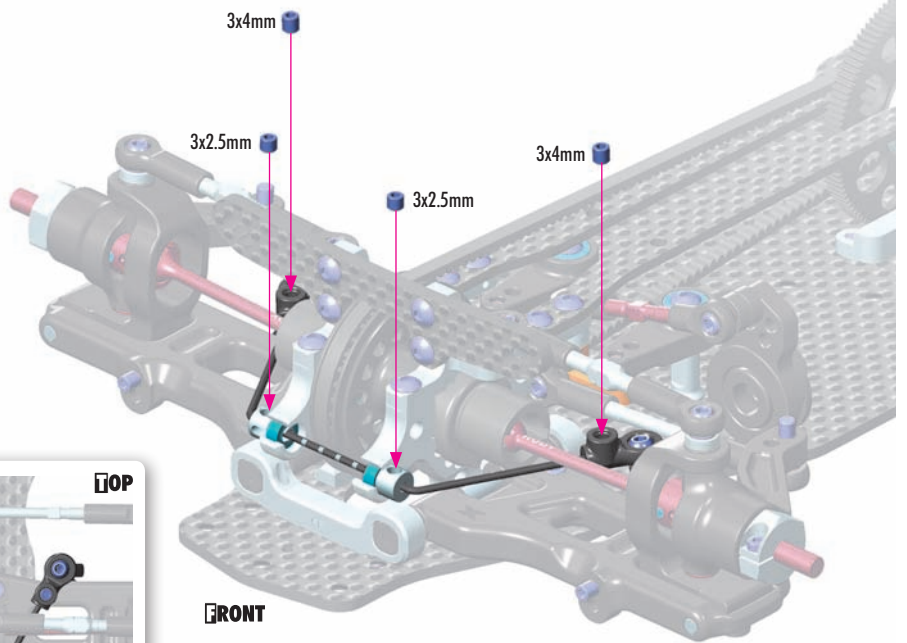

Set the bar into the center, remove the play in the bushings, and tighten the set-screws fully.

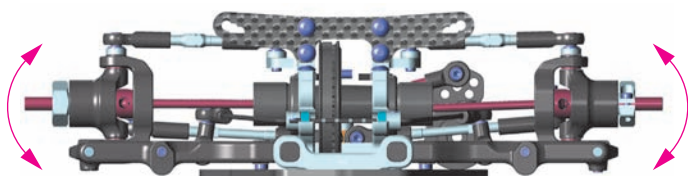

When the bars are set, verify that both sides move at the same time. If they do, the bars are set up correctly. If not, make sure that both downstops are the same and that the bar wire is flat.



If both sides still do not move at the same time, adjust the length of the bar holders.

# 5. FRONT & REAR TRANSMISSION

## REAR ANTI-ROLL BAR

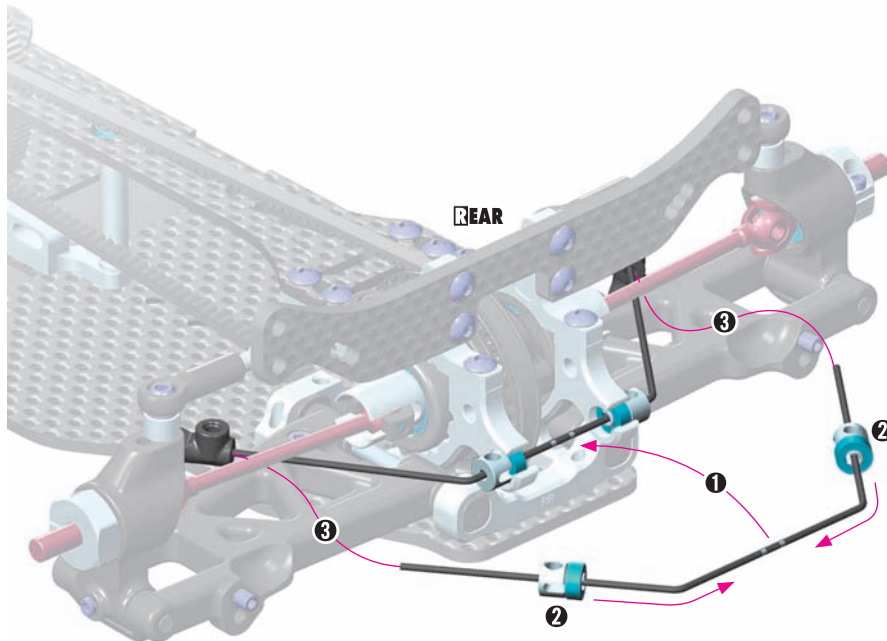

2x INITIAL POSITION

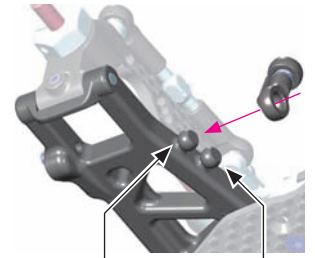

OUTER INNER

### ANTI-ROLL BAR POSITION

INITIAL SETTING = OUTER BALL

Use the **OUTER** ball on medium-high traction tracks. The car will roll less which will make it easier to drive with more cornering speed.

Use the **INNER** ball on low-traction tracks (mainly low-traction carpet tracks). The car will have more traction & more steering, but will be more difficult to drive because the car will roll more.



ANTI-ROLL BARS



901302  
SB M3x2.5



901304  
SB M3x4

## REAR ANTI-ROLL BAR

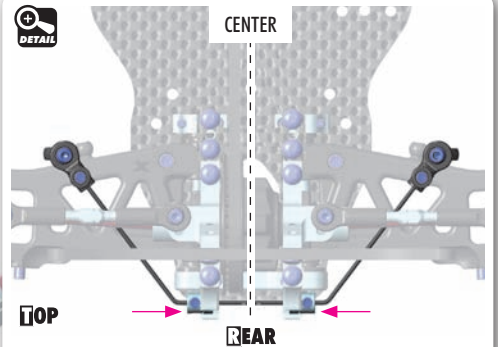
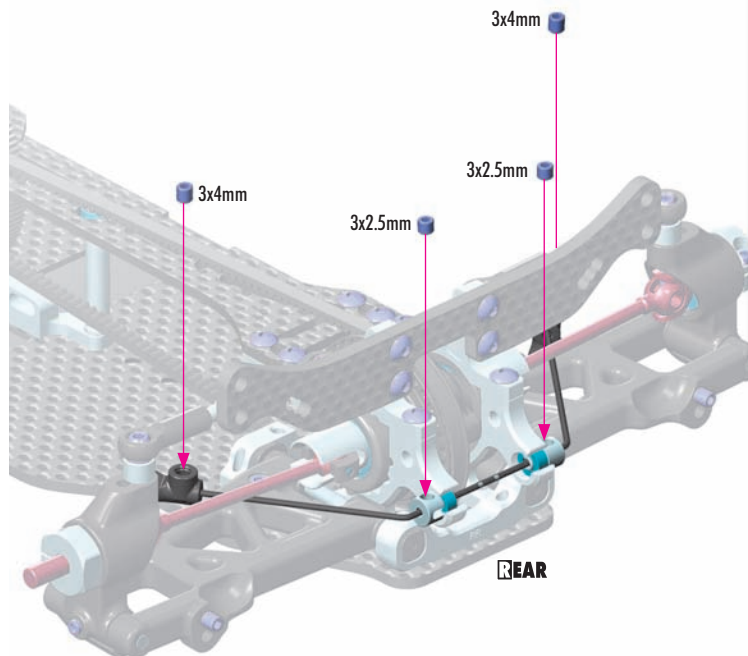

Set the bar into the center, remove the play in the bushings, and tighten the set-screws fully.

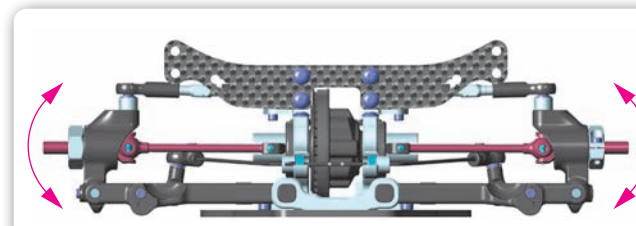

When the bars are set, verify that both sides move at the same time. If they do, the bars are set up correctly. If not, make sure that both downstops are the same and that the bar wire is flat.



If both sides still do not move at the same time, adjust the length of the bar holders.

# 6. SHOCK ABSORBERS

4x

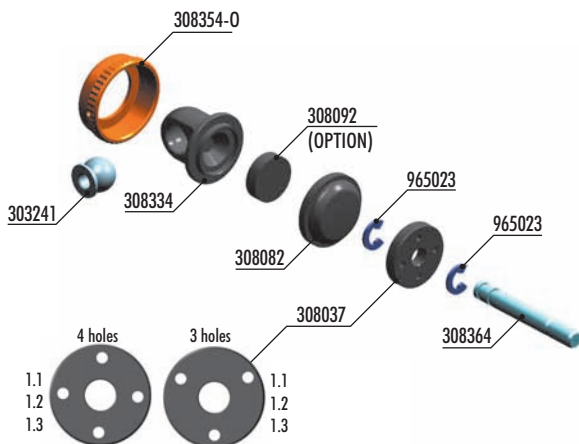

#104002  
HUDY AIR VAC – VACUUM PUMP - ON-ROAD



### XRAY SPRINGS

#	C	OPTION
#308263	C = 2.3-2.6	OPTION
#308264	C = 2.5-2.8	OPTION
#308274	C = 2.3	OPTION
#308275	C = 2.5	INCLUDED
#308286	C = 2.6	OPTION
#308276	C = 2.7	OPTION
#308288	C = 2.8	OPTION
#308277	C = 2.9	OPTION
#308290	C = 3.0	OPTION



#308308-K  
ULP ALU SHOCK ABSORBER-SET - BLACK (2)



#308031-O  
ALU XRAY SHOCK SPRING RETAINING COLLAR - ORANGE (4)



#308031-K  
ALU XRAY SHOCK SPRING RETAINING COLLAR - BLACK (4)



#308029  
ULP ALU PROGRESSIVE SHOCK SYSTEM - SET (2)

Progressive shock system for touring cars for improved traction and steering characteristics. Shock insert with 3 triangular cutouts used with piston WITHOUT holes. The hardness of the shock is influenced not by the holes in the piston, but rather by the insert.



BAG

06

- 303241 BALL UNIVERSAL 5.8 MM HEX (4)
- 308037 COMPOSITE PISTONS 4-HOLE 1.0-1.2MM, 3-HOLE 1.0-1.2MM
- 308044-0 ULP ALU SHOCK ADJUSTABLE NUT - ORANGE (2)
- 308082 T4 SHOCK ABSORBER MEMBRANE (4)
- 308092 T4 SHOCK FOAM INSERTS (4) (OPTION)
- 308308-0 ULP ALU SHOCK ABSORBER-SET - ORANGE (2)
- 308316 SHOCK BALL JOINT - OPEN (4)
- 308324 ULP ALU SHOCK BODY (2)
- 308327-0 ALU CAP FOR XRAY SHOCK BODY - ORANGE

- 308334 ULP COMPOSITE SHOCK PARTS
- 308354-0 ULP ALU SHOCK CAP-NUT WITH VENT HOLE - ORANGE (2)
- 308364 T4 HARDENED SHOCK SHAFT FOR ALU SHOCKS (2)
- 308275 XRAY SPRING-SET C=2.5
- 965023 E-CLIP 2.3 (10)
- 970131 O-RING 13 x 1.0 (10)
- 972030 SILICONE O-RING 3 x 2 (10)

965023  
C 2.3

4x

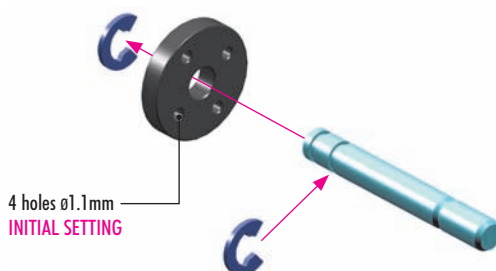

# 6. SHOCK ABSORBERS

**OIL**  
972030  
Ø 3x2

**4x**

SHOCK OIL

SHOCK OIL

NOTE ORIENTATION

**OIL**  
970131  
Ø 13x1.0

**4x**

SHOCK OIL

SHOCK OIL

1

2

CUTAWAY VIEW

Be careful not to cross-thread the collar on the shock body.

**4x**

INCORRECT ✗

CORRECT ✓

**TIP** Install the ball joint with Professional Multi Tool (HUDY #183011)

**TIP** 1mm

INITIAL SETTING

**HINT:** Pre-thread the ball joint using an M3 screw.  
**WARNING!** Be careful not to pre-thread too far, since the ball joint may split or the plastic threads may strip out.

**OIL 450cSt**

**SHOCK FILLING**

- 1 Fully extend the piston rod so the piston is at the bottom of the shock body.
- 2 Hold the shock upright and slightly overfill the shock body with shock oil.
- 3 Let the oil settle and allow air bubbles to rise to the top. Slowly move the piston up and down to allow oil into all cavities within the shock body.
- 4 Extend the piston rod most of the way out of the shock body. Let the shock rest for 5 minutes to allow the air bubbles to escape.
- 5 Add shock oil as necessary.

**TIP** **OPTION HUDY** #104002 HUDY AIR VAC – VACUUM PUMP

SHOCK OILS (50ml)	
#106325	250cSt
#106330	300cSt
#106335	350cSt
#106340	400cSt
INCLUDED #106345	450cSt
#106350	500cSt
#106355	550cSt
#106360	600cSt
#106365	650cSt
#106370	700cSt
#106375	750cSt
#106380	800cSt

To make sure that all the air is removed from the shock oil, we recommend using the HUDY Air Vac.

**4x**

Foam insert (OPTION)

CUTAWAY VIEW

After you insert the membrane, ensure that it is fully seated inside the alu cap.

# 6. SHOCK ABSORBERS



- 1 When installing the shock cap assembly on the shock body, some oil will leak out... this is normal.
- 2 Tighten the cap and clean off any excess oil.
- 3 After the shock is assembled, the shock rod will push itself out of the shock body fairly quickly.
- 4 Follow the next procedure to adjust the rebound.

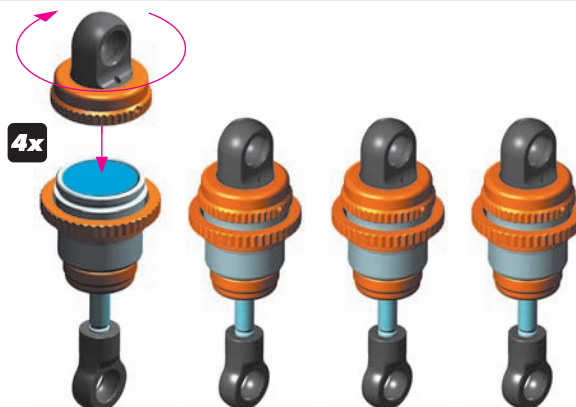

4x

## REBOUND ADJUSTMENT

RELEASE 2-3 turns

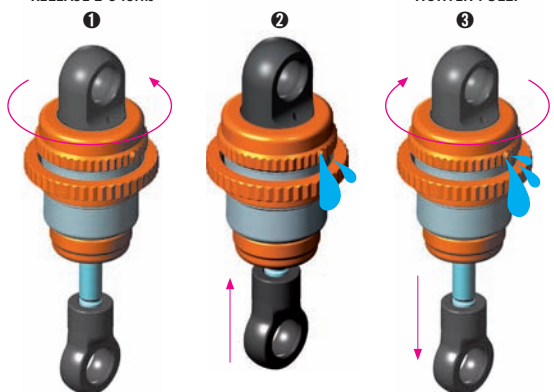

### AFTER THE SHOCK IS ASSEMBLED YOU HAVE TO SET THE SHOCK REBOUND:

- 1 Release the shock cap by 2-3 turns.
- 2 Push the shock shaft fully up. For the first time the extra oil will release through the hole in the alu cap-nut.
- 3 Tighten the shock cap. When tightening the shock cap, extra oil will again release through the hole in the alu cap - nut. When tightening, the shock shaft will push out from the shock body.

4x

## REBOUND CHECK

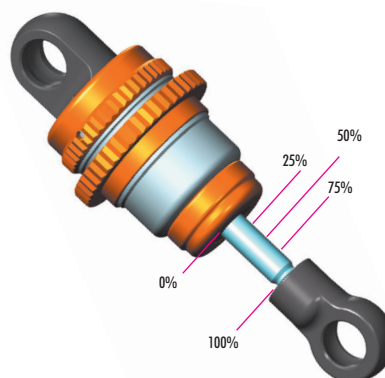

### REBOUND CHECK:

It is very important to push the shock shaft into the shock body slowly otherwise air can come into the shock body which would create bubbles.

- 100% rebound - do not do step 2 and 3
- 75% rebound - repeat steps 1 to 3 until the shock shaft will push out 75% of its length
- 50% rebound - repeat steps 1 to 3 until the shock shaft will push out 50% of its length
- 25% rebound - repeat steps 1 to 3 until the shock shaft will push out 25% of its length
- 0% rebound - repeat steps 1 to 3 until the shock shaft will push out 0% of its length

If the shock shaft does not rebound enough, you will have to refill the shock with shock oil, and then repeat the bleeding and rebound adjustment procedure.

### 4x SHOCK LENGTH ADJUSTMENT:

It is VERY IMPORTANT that all shocks are equal length.

Fully extend the shock absorber and measure the end-to-end length; we recommend using digital calipers to give an accurate measurement. If a shock absorber is shorter or longer than others, adjust the shock length by tightening or loosening the ball joint on the shock rod.

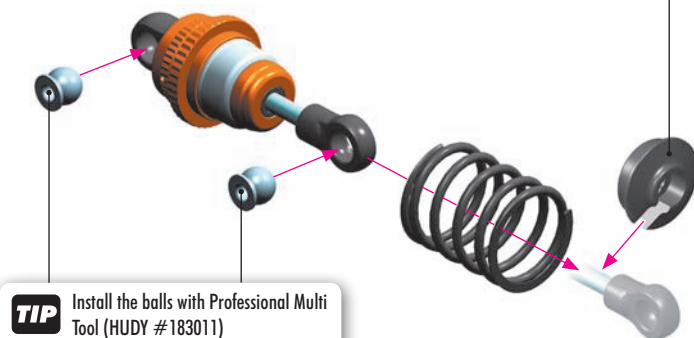

**TIP** Install the balls with Professional Multi Tool (HUDY #183011)



**OPTION** #308031-0 ALU XRAY SHOCK SPRING RETAINING COLLAR - ORANGE (4)



**OPTION** #308031-K ALU XRAY SHOCK SPRING RETAINING COLLAR - BLACK (4)



ASSEMBLY VIEW



# 7. FRONT & REAR ASSEMBLY

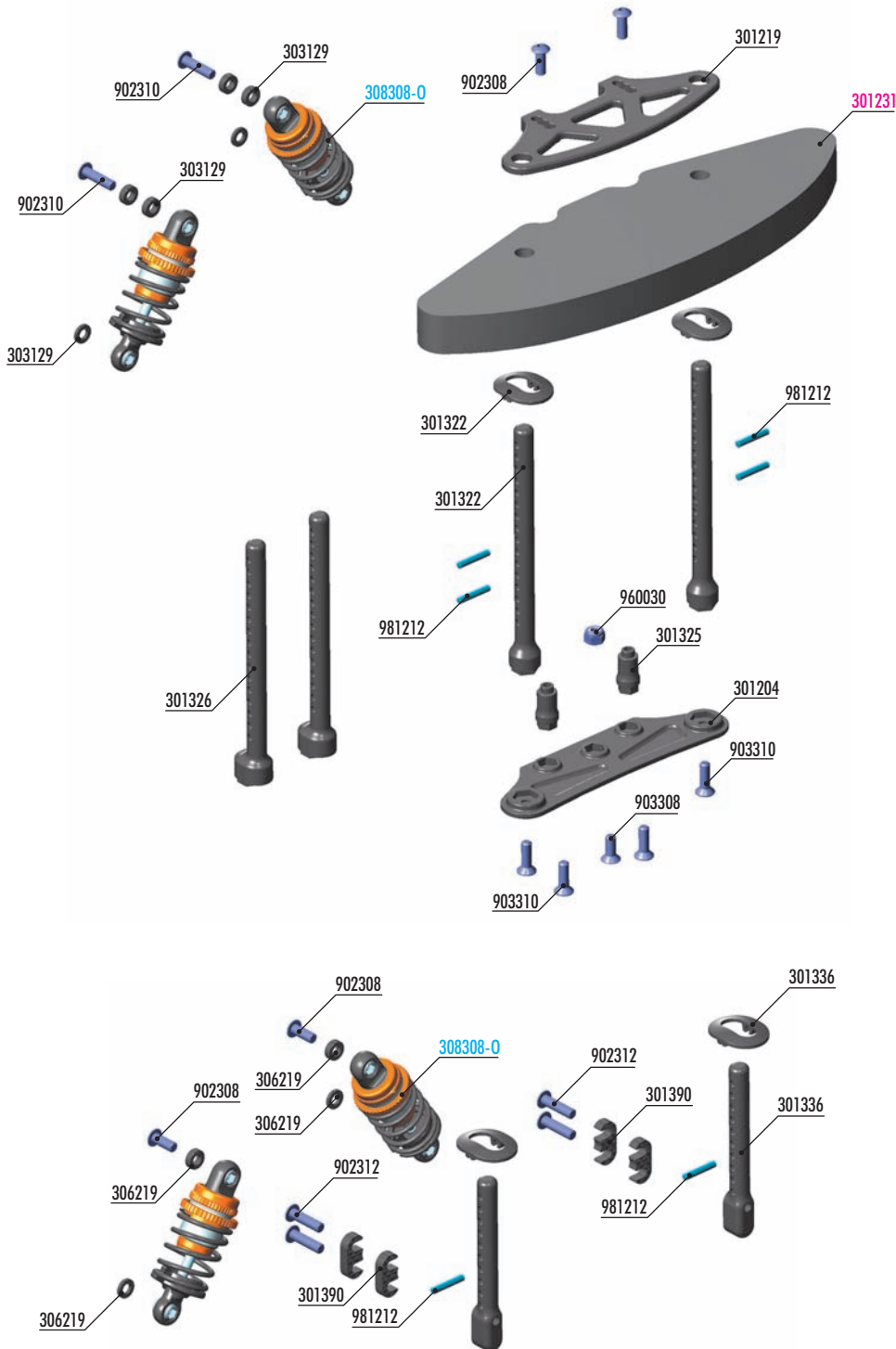

**OPTION** **REAR BODY MOUNT SET**

#301336	0mm	INCLUDED
#301337	+1mm	OPTION
#301338	+2mm	OPTION



**OPTION** **FRONT BODY MOUNT SET**

#301322	0mm	INCLUDED
#301323	+1mm	OPTION
#301324	+2mm	OPTION

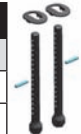

**OPTION** **FRONT ECC. BODY MOUNT SET**

#301326	0mm	INCLUDED
#301327	+1mm	OPTION
#301328	+2mm	OPTION



**OPTION** **#301351-0**  
ALU ADJUSTABLE BODY POST STOP (2)



**OPTION** **#301210**  
GRAPHITE UPPER HOLDER FOR BUMPER 2.5MM



**OPTION** **#301232**  
T4 FOAM BUMPER WIDE - HARD



**BAG**

**07**

- 301204 COMPOSITE BUMPER
- 301219 COMPOSITE UPPER HOLDER FOR BUMPER
- 301322 FRONT BODY MOUNT SET
- 301326 FRONT ECCENTRIC BODY MOUNT SET
- 301325 T4 COMPOSITE BRACE FOR BUMPER - LOW (2)
- 301336 REAR BODY MOUNT SET
- 301390 GRAPHITE ADJ. SHIM FOR REAR BODY POST 3.0MM (2)
- 303129 COMPOSITE SET OF WHEELBASE SHIMS (3x1MM; 1x2MM) (2)
- 306219 COMPOSITE SET OF SERVO SHIMS (4)

- 902308 HEX SCREW SH M3x8 (10)
- 902308 HEX SCREW SH M3x8 (10)
- 902310 HEX SCREW SH M3x10 (10)
- 903308 HEX SCREW SFH M3x8 (10)
- 903310 HEX SCREW SFH M3x10 (10)
- 960030 NUT M3 (10)
- 981212 PIN 2x12 (10)

**301231 T4 FOAM BUMER - LIGHT & STRONG**

**308308-0 ULP ALU SHOCK ABSORBER-SET - ORANGE (2)**

# 7. FRONT & REAR ASSEMBLY

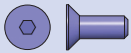

903308  
SFH M3x8

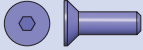

903310  
SFH M3x10



960030  
N M3

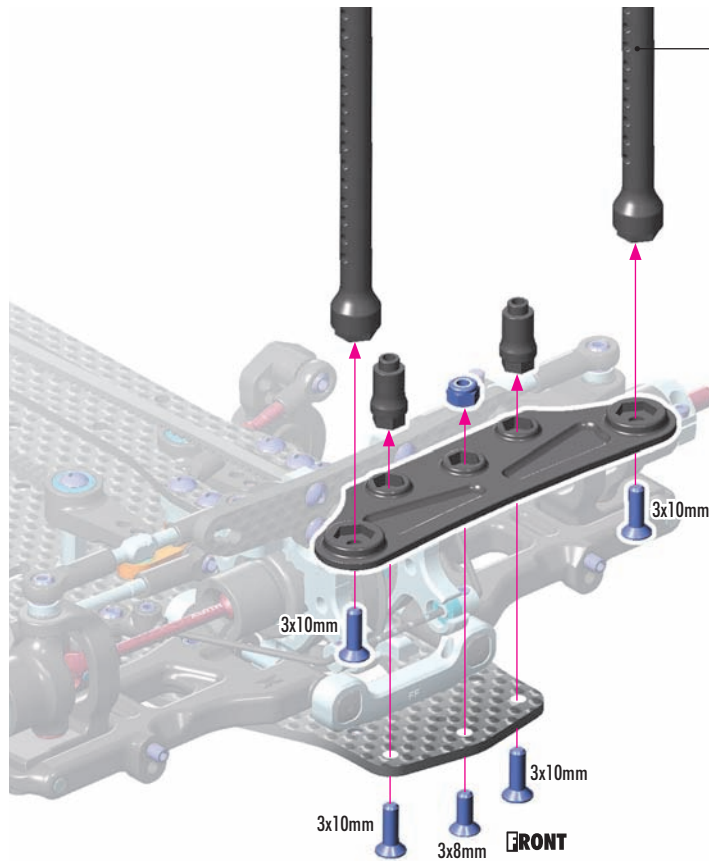

## FRONT BODY POST ORIENTATION

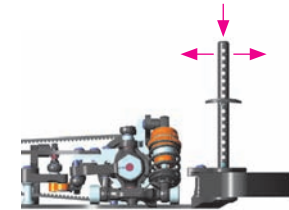
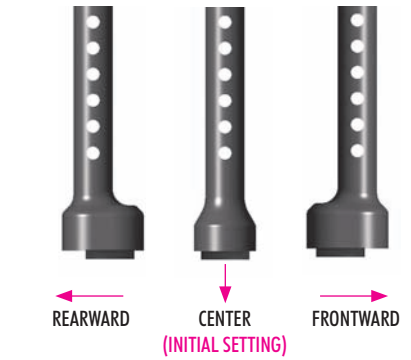

FRONT

It is important to use the same body setting (rearward, center, forward) both on front and rear body posts at the same time.

**TIP** This new, innovative & unique feature allows adjustment of the body position for all kind of surfaces, traction conditions, touring classes, using only one body. There are three different body positions; rearward, center, and forward. Depending on the conditions the body posts position can be easily changed which allows the body to be moved.

- The body in the **REARWARD POSITION** makes the car super stable and very easy to drive. It makes the car easier to drive over chicanes and be more predictable in high-traction conditions.
- The body in the **CENTER POSITION** makes the car more aggressive and steer faster, but is a bit more difficult to drive in low-grip conditions.
- The body in the **FORWARD POSITION** is the most aggressive. It makes the car steer a lot, but is more difficult to drive when the traction is high or when the track has a lot of chicanes.

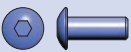

902308  
SH M3x8



FRONT

#301232  
T4 FOAM BUMPER WIDE - HARD

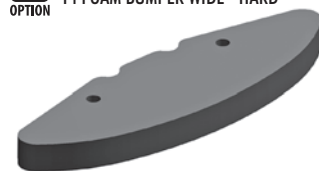

INITIAL SETTING



#301210  
GRAPHITE UPPER HOLDER FOR BUMPER 2.5mm  
(Alu shim 4x6x2mm - INCLUDED)

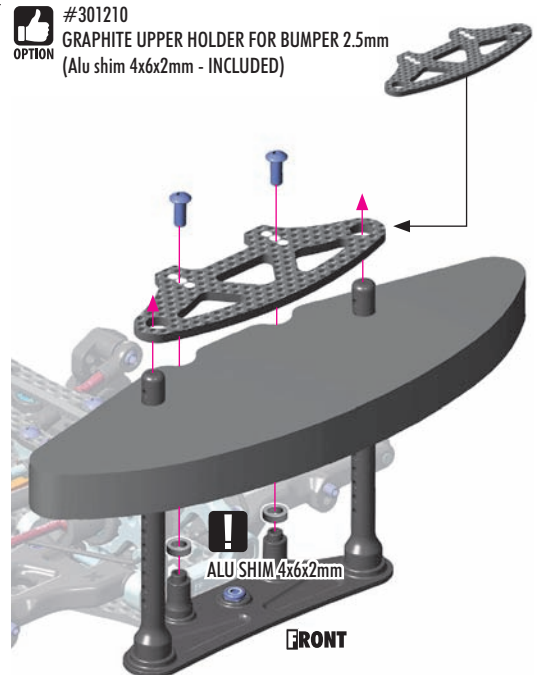

FRONT

ALU SHIM 4x6x2mm

# 7. FRONT & REAR ASSEMBLY



981212  
P 2x12

2x  
L=R

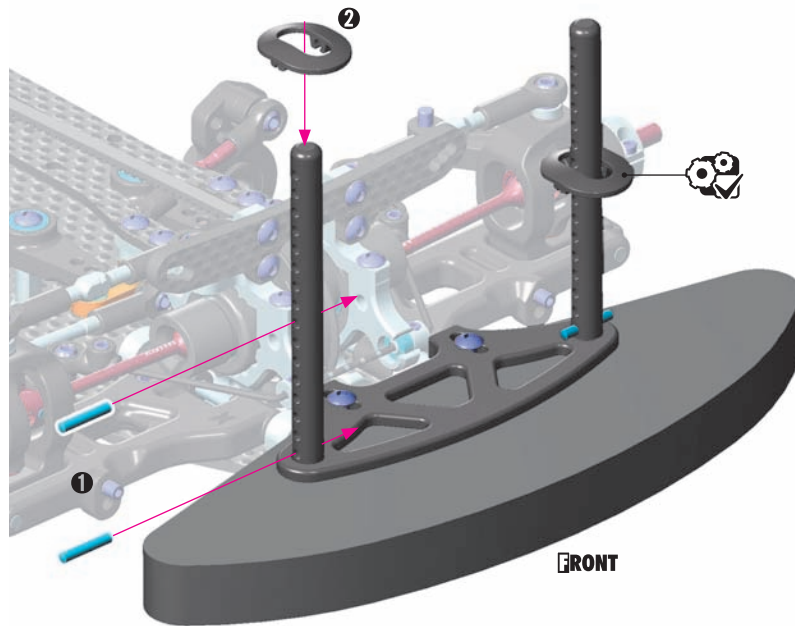

#301351-0  
ALU ADJUSTABLE BODY POST STOP (2)



Very handy, easily externally adjustable body post from Swiss 7075 T6 aluminum. Allows for adjustment of body height by 3mm without needing to change the position on the body post.



FRONT ECC. BODY MOUNT SET

#301326	0mm	INCLUDED
#301327	+1mm	OPTION
#301328	+2mm	OPTION



FRONT BODY MOUNT SET

#301322	0mm	INCLUDED
#301323	+1mm	OPTION
#301324	+2mm	OPTION

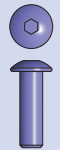

902310  
SH M3x10



303129  
SHIM 3x6x1



303129  
SHIM 3x6x2

L=R

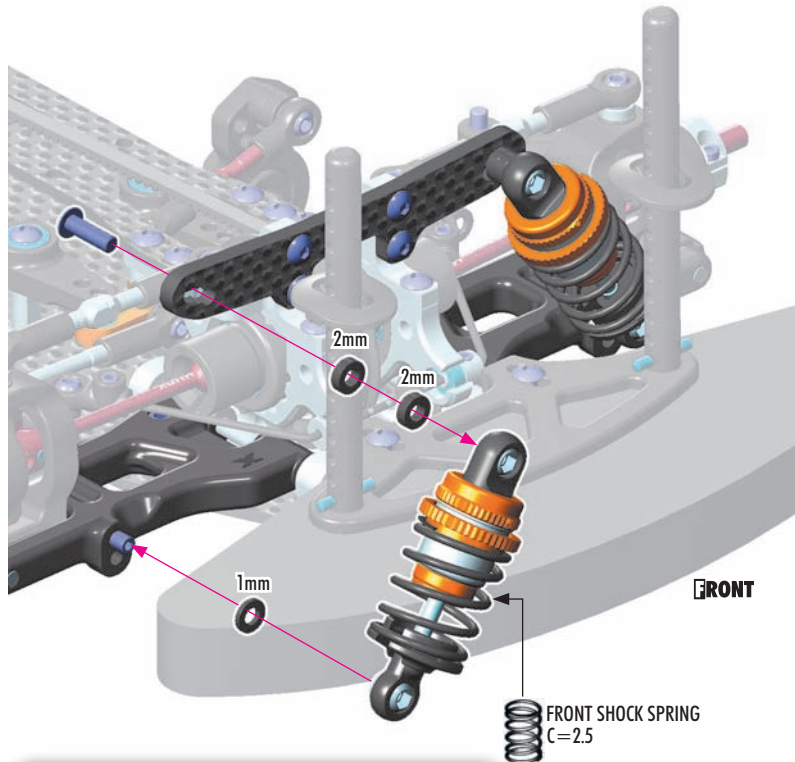

INITIAL SETTING



#308307-0  
XRAY T4 ALU SHOCK ABSORBER-SET - ORANGE (2)



#301962  
SLP SHOCK TOWER FRONT 3.0MM GRAPHITE

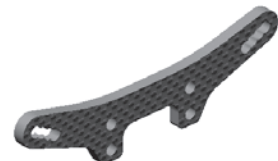

For some very specific racing conditions like extremely-low traction, these SLP shocks with SLP shock tower are available as an option.



#308029  
ULP ALU PROGRESSIVE SHOCK SYSTEM - SET (2)



The information about optional lower shock tower is at the end of the manual.



SHOCK POSITION  
RIDE HEIGHT  
DROOP



# 7. FRONT & REAR ASSEMBLY



902312  
SH M3x12



981212  
P 2x12

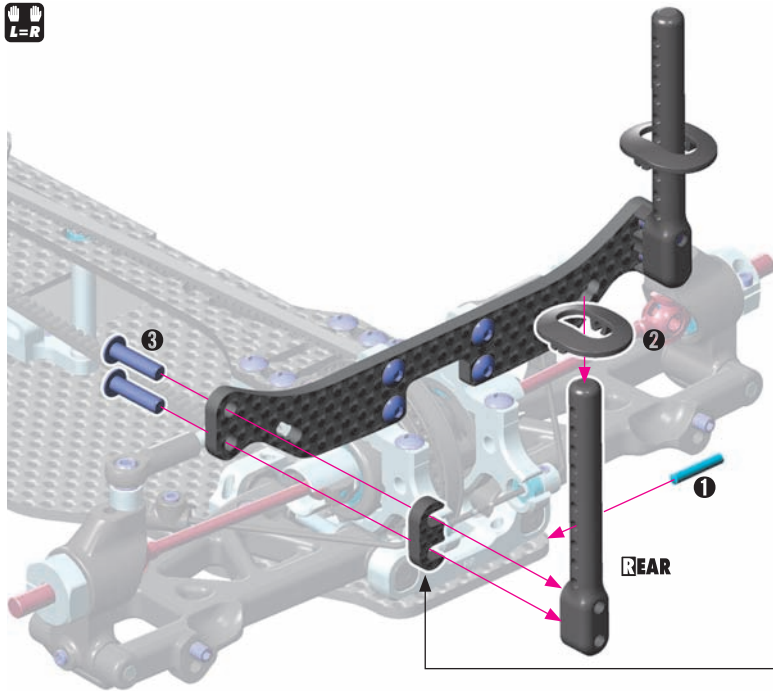

## REAR BODY POST POSITION

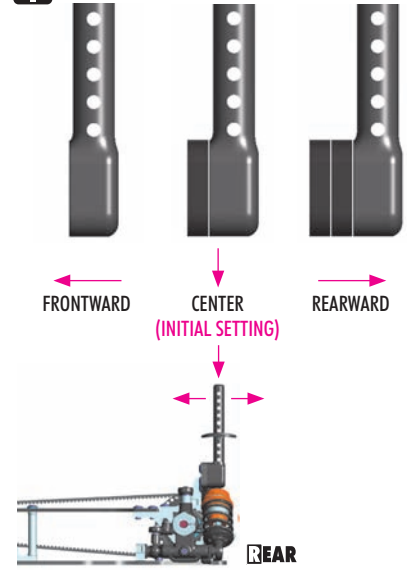

It is important to use the same body setting (rearward, center, forward) both on front and rear body posts at the same time.



#301351-0  
ALU ADJUSTABLE BODY POST STOP (2)

Very handy, easily externally adjustable body post from Swiss 7075 T6 aluminum. Allows for adjustment of body height by 3mm without needing to change the position on the body post.



## REAR BODY MOUNT SET

Part Number	Offset	Status
#301336	0mm	INCLUDED
#301337	+1mm	OPTION
#301338	+2mm	OPTION

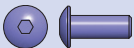

902308  
SH M3x8



306219  
SHIM 3x6x1



306219  
SHIM 3x6x2



The information about optional lower shock tower is at the end of the manual.

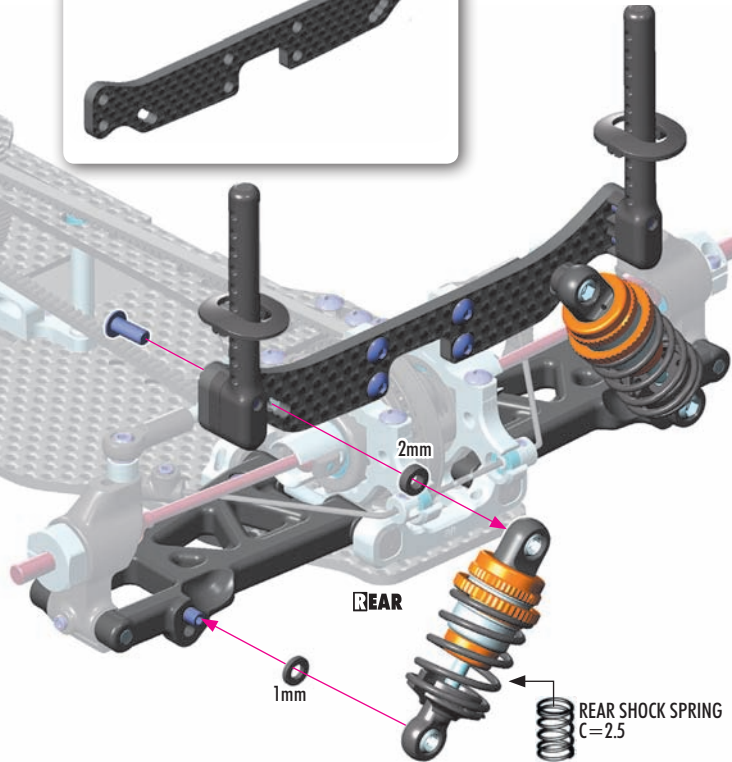

#308307-0  
XRAY T4 ALU SHOCK ABSORBER-SET - ORANGE (2)



#302962  
SLP SHOCK TOWER REAR 3.0MM GRAPHITE



For some very specific racing conditions like extremely-low traction, these SLP shocks with SLP shock tower are available as an option.



#308029  
ULP ALU PROGRESSIVE SHOCK SYSTEM - SET (2)



SHOCK POSITION  
RIDE HEIGHT  
DROOP

# 7. FINAL ASSEMBLY

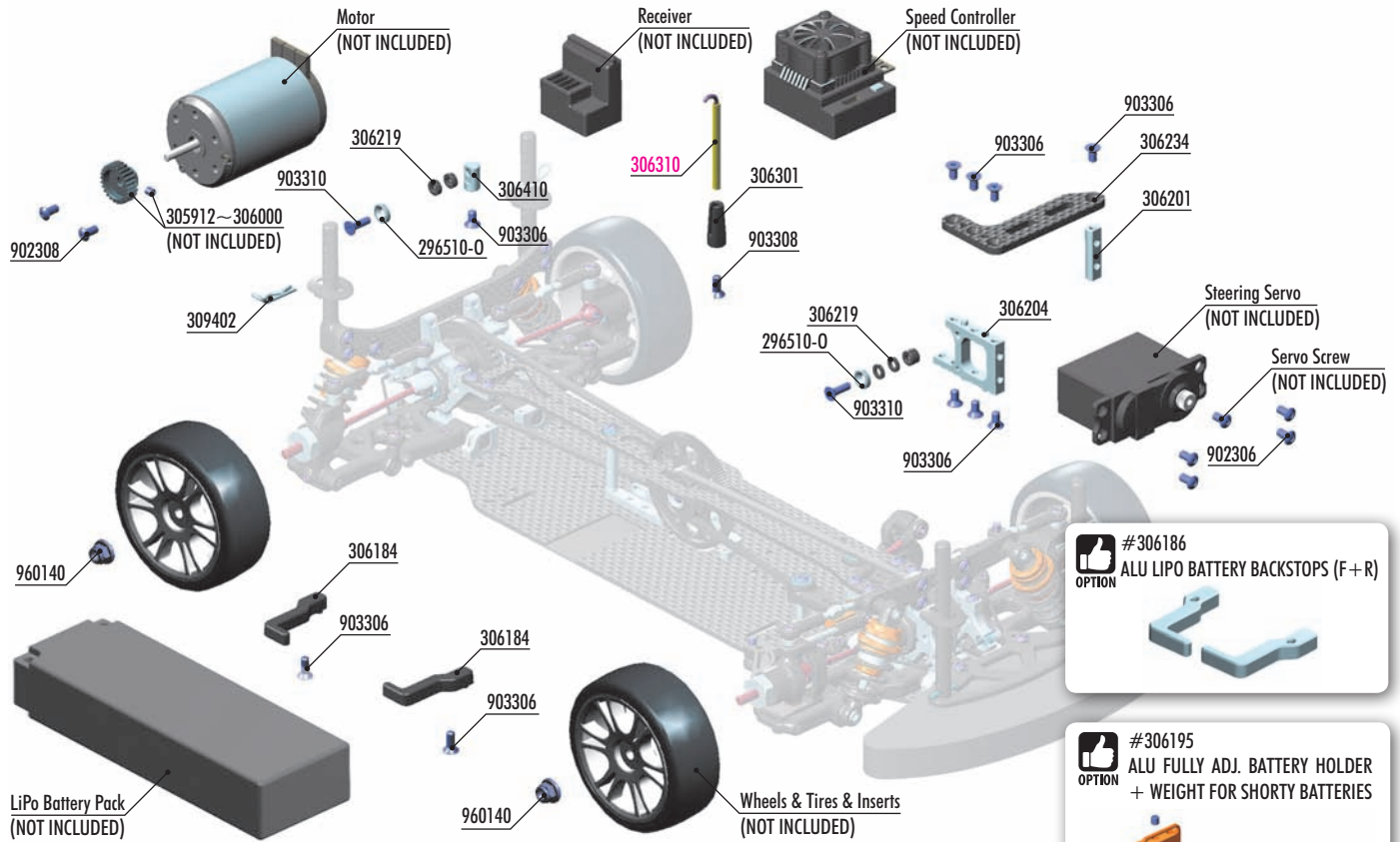

**#306186**  
 ALU LIPO BATTERY BACKSTOPS (F+R)  
 OPTION

**#306195**  
 ALU FULLY ADJ. BATTERY HOLDER  
 + WEIGHT FOR SHORTY BATTERIES  
 OPTION

**#353561** SILVER XRAY OPTION  
**#293561** SILVER HUDY OPTION  
**#293561-0** ORANGE HUDY OPTION

**ALU REAR WING SHIM**  
 OPTION

**#306165**  
 GRAPHITE BATTERY STRAP  
 OPTION

**#306551**  
 XRAY PURE TUNGSTEN  
 CHASSIS WEIGHT 11g  
 OPTION

**#306191**  
 T4 GRAPHITE + ALU FULLY  
 ADJUSTABLE BATTERY HOLDER  
 OPTION

**#306194**  
 T4 GRAPHITE + BRASS FULLY  
 ADJUSTABLE BATTERY HOLDER  
 OPTION

**#306410**  
 ALU FAN MOUNT  
 OPTION

**BAG**  
**07**

- 296510-0 ALU COUNTERSUNK SHIM - ORANGE (10)
- 305912~306000 NARROW PINION GEAR ALU HARD COATED (OPTION)
- 306184 LONG COMPOSITE LIPO BATTERY BACKSTOP (1+1)
- 306201 ALU SERVO MOUNT - LONG
- 306204 ALU SERVO MOUNT - BLACK
- 306219 COMPOSITE SET OF SERVO SHIMS (4)
- 306234 GRAPHITE FLOATING SERVO HOLDER NARROW 3.0MM
- 306301 ANTENNA MOUNT - THIN
- 306410 ALU UNIVERSAL MOUNT

- 309402 BODY CLIP FOR 6MM BODY POST (4)
- 902306 HEX SCREW SH M3x6 (10)
- 902308 HEX SCREW SH M3x8 (10)
- 903306 HEX SCREW SFH M3x6 (10)
- 903308 HEX SCREW SFH M3x8 (10)
- 903310 HEX SCREW SFH M3x10 (10)
- 960140 NUT M4 WITH FLANGE (10)

**306310** ANTENNA (2)

- 306219 SHIM 3x6x3
- 303129 SHIM 3x6x1
- 902306 SH M3x6
- 903310 SFH M3x10
- 903306 SFH M3x6

**!** The thickness of the shim may be changed depending on the position of the batteries you want to use.

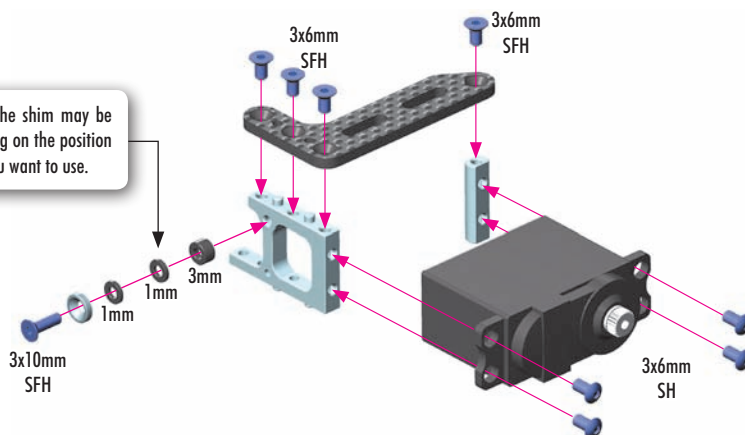

# 7. FINAL ASSEMBLY



903306  
SFH M3x6

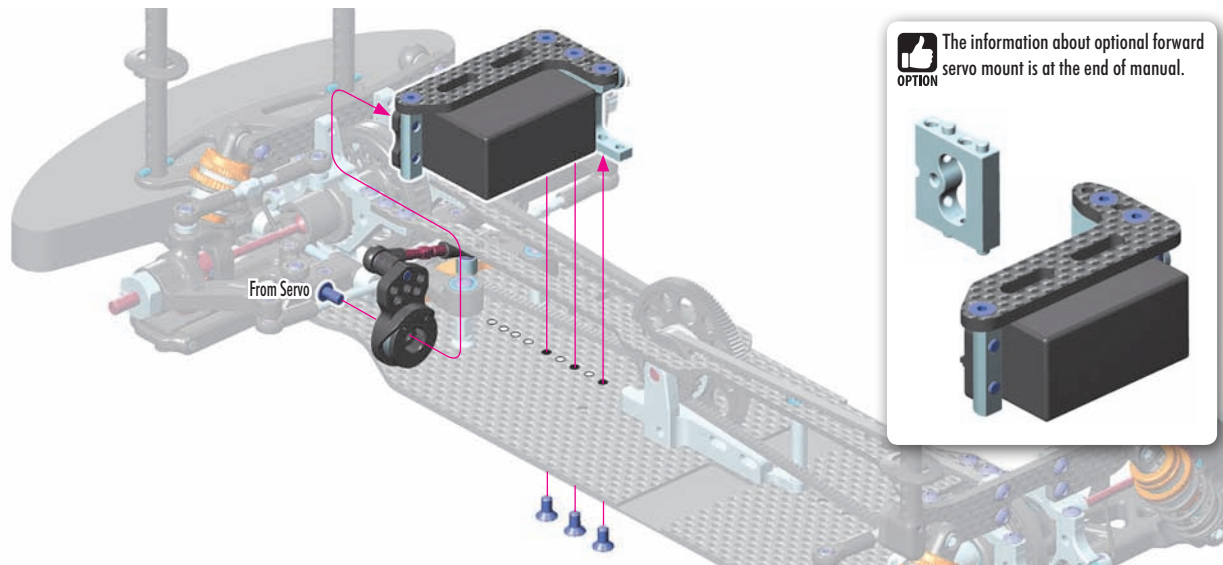

**OPTION** The information about optional forward servo mount is at the end of manual.

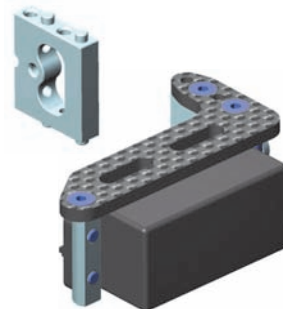

For improved weight balance and for more space for electronics, we recommend using a narrow, light servo.



**IMPORTANT!**



When adjusting steering on the radio, we recommend using full steering adjustment in order to get the best steering from the car. It is important to verify that the steering block does not touch the C-hub; that would lead to chassis tweak due to extra servo strain.

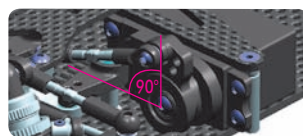

Attach servo arm to servo output shaft using screw from servo. Servo saver must be perpendicular to chassis when servo is in neutral.



902308  
SH M3x8



**OPTION** #306410  
ALU FAN MOUNT

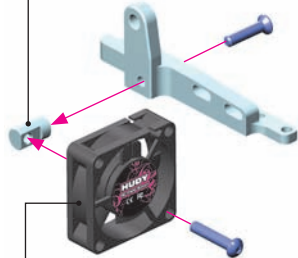

**OPTION** #293110 HUDY BRUSHLESS RC FAN 30MM  
#293111 HUDY BRUSHLESS RC FAN 40MM

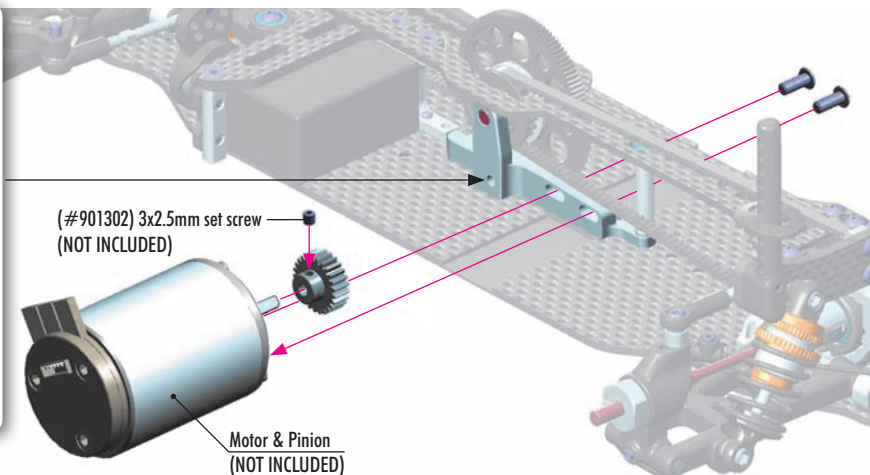

(#901302) 3x2.5mm set screw  
(NOT INCLUDED)

Motor & Pinion  
(NOT INCLUDED)

Adjust the motor so the pinion meshes with the spur gear properly. Make sure the gear mesh is not too tight.

There should be a small amount of play between the teeth of the pinion gear and the spur gear.

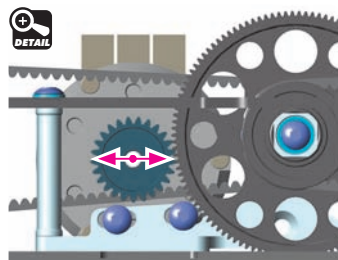

**TIP**

Some motors do not have a chamfer on the motor housing. If your motor does not have a chamfer on the housing and you want to use a small pinion, the motor may touch the top deck. Use a moto-tool with grinding bit or file to remove material from the top deck; this will allow the motor to be moved closer to the spur gear or you can shim out the motor by using #303122-0 (3x6x1mm) shims.

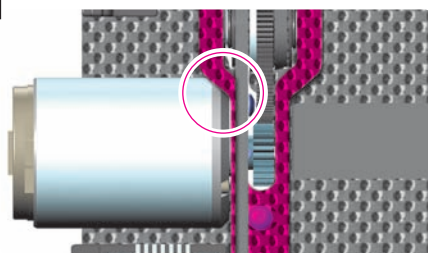

# 7. FINAL ASSEMBLY

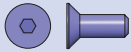

903308  
SFH M3x8

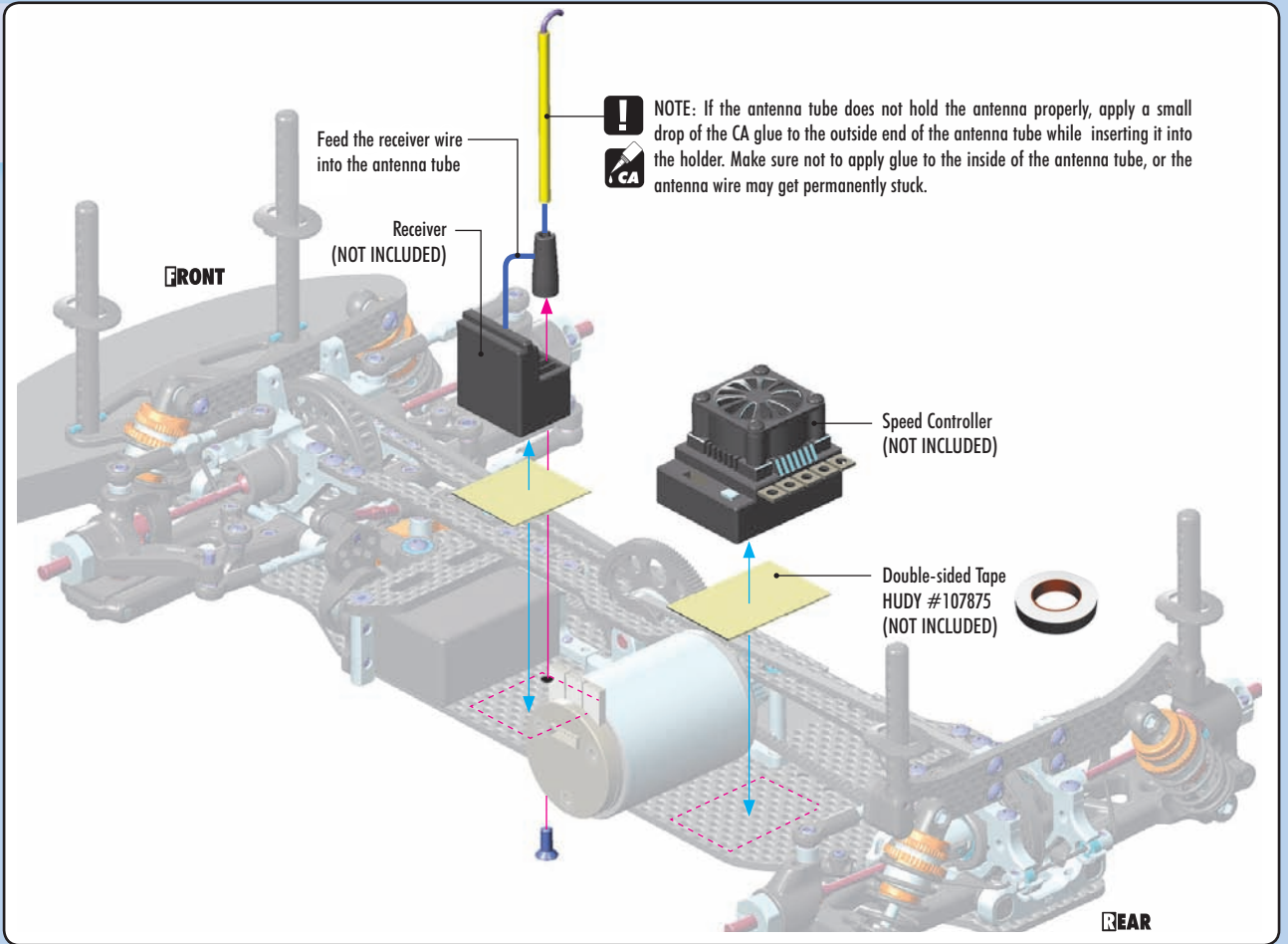

306219  
SHIM 3x6x3



903306  
SFH M3x6



903310  
SFH M3x10

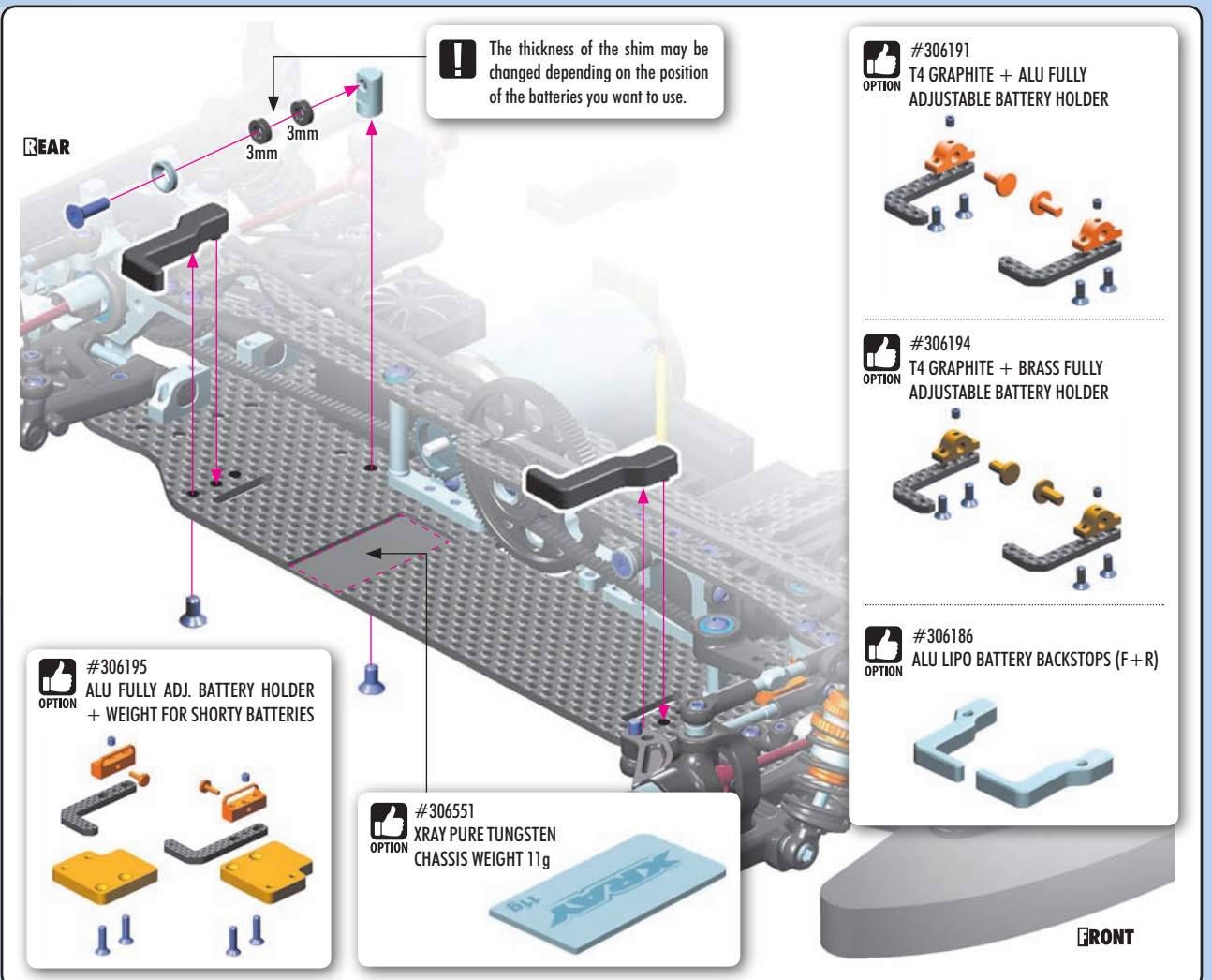

# 7. FINAL ASSEMBLY



LiPo Battery Pack (NOT INCLUDED)

4x

Make sure the wheel nuts are very tight, so the wheels do not loosen during operation.

We recommend using #107870 HUDY Fibre-reinforced Tape (NOT INCLUDED)

#306165 GRAPHITE BATTERY STRAP  
OPTION  
Designed for LiPo batteries to ensure quick & easy mounting of the battery pack the in car. Depending on the LiPo battery height, additional shims may have to be mounted below the stands.

ALU REAR WING SHIM  
OPTION

#353561	SILVER	XRAY	OPTION	
#293561	SILVER	HUDY	OPTION	
#293561-0	ORANGE	HUDY	OPTION	

## EXTRA INFORMATION ABOUT OPTIONAL PARTS FOR T4'20

OPTION

#300902  
T4'20 ACTIVE REAR SUSPENSION™ SET  
OPTION

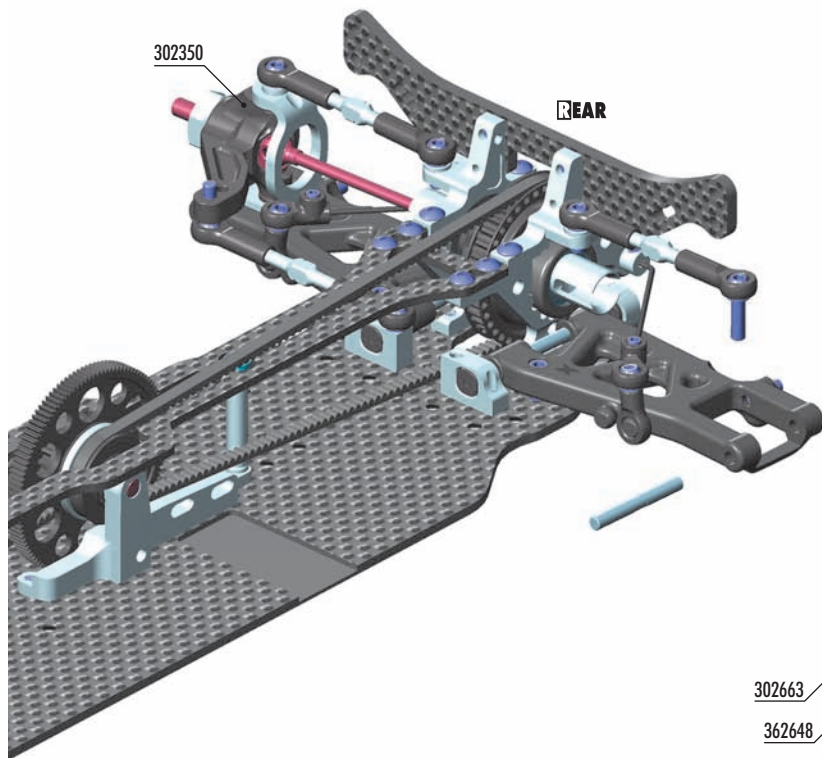

ALU C-HUB ACTIVE REAR SUSP.  
OPTION

#302350	0°	-	INCLUDED	
#302351	2°	RIGHT	OPTION	
#302352	2°	LEFT	OPTION	
#302353	4°	RIGHT	OPTION	
#302354	4°	LEFT	OPTION	

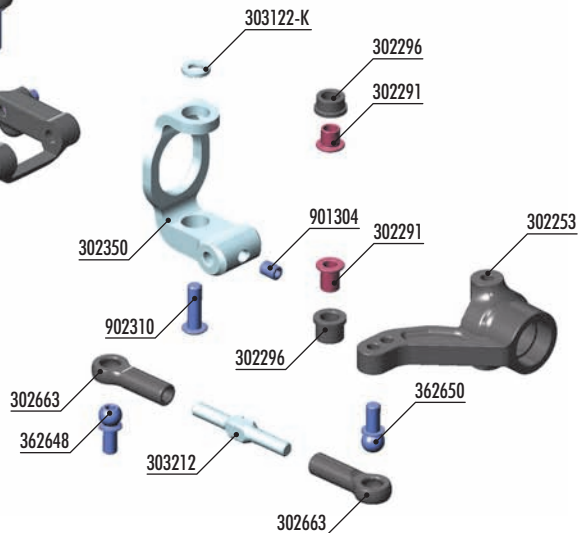



902205  
SH M2x5

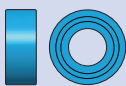

940510  
BB 5x10x4



980210  
P 2x10

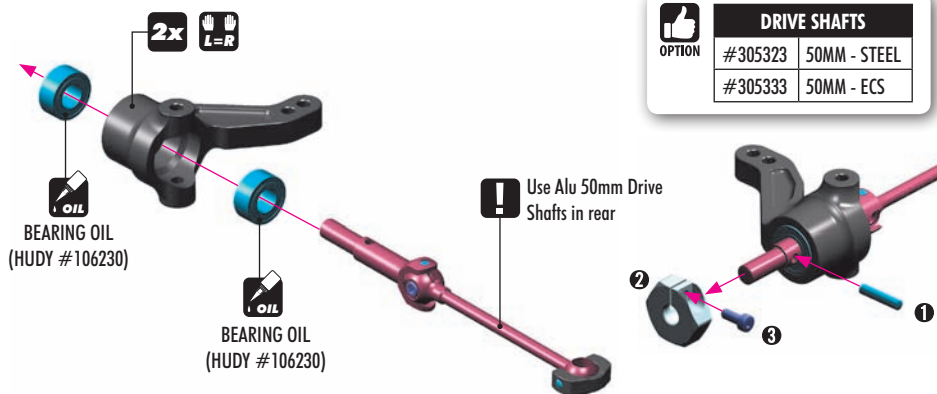

BEARING OIL  
(HUDY #106230)

BEARING OIL  
(HUDY #106230)

Use Alu 50mm Drive Shafts in rear



### DRIVE SHAFTS

#305323	50MM - STEEL
#305333	50MM - ECS

ALU WHEEL HUBS - OFFSET		
INCLUDED	#305350-K	(0 mm)
	#305351	(-0.75 mm)
	#305352	(+0.75 mm)
	#305353	(+1.5 mm)

STEERING BLOCKS		
	#302252	MEDIUM
INCLUDED	#302253	HARD
	#302254	GRAPHITE
	#302256	ALU



902310  
SH M3x10

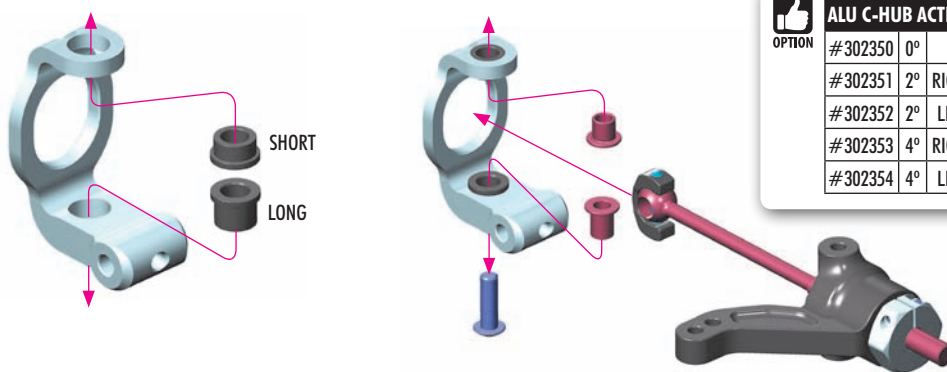

SHORT

LONG



### ALU C-HUB ACTIVE REAR SUSP.

#302350	0°	-	OPTION
#302351	2°	RIGHT	OPTION
#302352	2°	LEFT	OPTION
#302353	4°	RIGHT	OPTION
#302354	4°	LEFT	OPTION



303122-K  
SHIM 3x6x1



901304  
SB M3x4

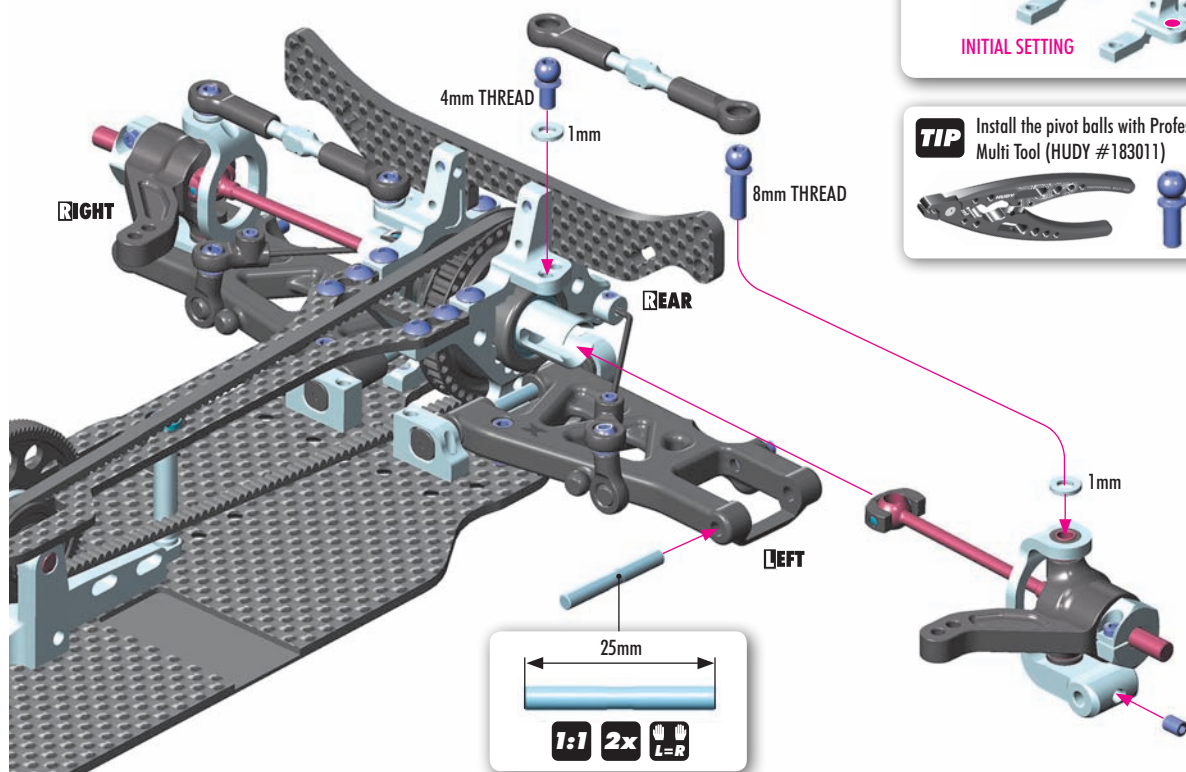

RIGHT

REAR

LEFT

4mm THREAD  
1mm

8mm THREAD

25mm

1:1 2x L=R



INITIAL SETTING



**TIP** Install the pivot balls with Professional Multi Tool (HUDY #183011)



#307322 TITANIUM REAR ARM PIVOT PIN (2)





303122-K  
SHIM 3x6x1

### ARS™ MOUNTING ALTERNATIVES

There are two alternatives how to mount ARS linkage. Depending if you want to have increased or decreased toe-in when the car is pressed

#### ALTERNATIVE DECREASING TOE-IN

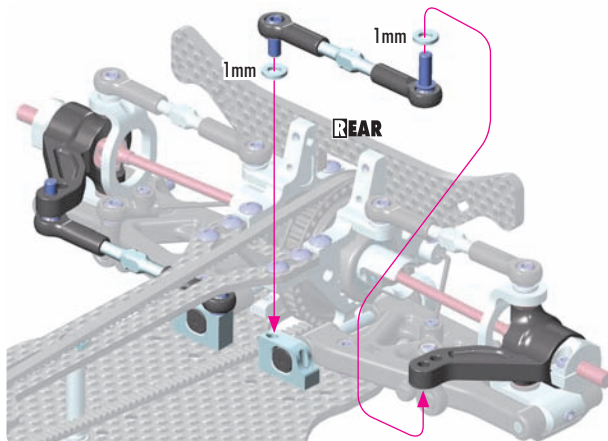

The link is mounted from the bottom of the steering block to the RF suspension holder. With this setting, the toe-in decreases when the car is pressed. This means that if you set the toe-in to 3°, then when the car enters the corner, the toe-in decreases which increases cornering speed but decreases rear traction. Recommended for medium-high traction conditions.

By adding more shims under steering block, the toe-in is more decreasing under pressing the car.

#### ALTERNATIVE INCREASING TOE-IN

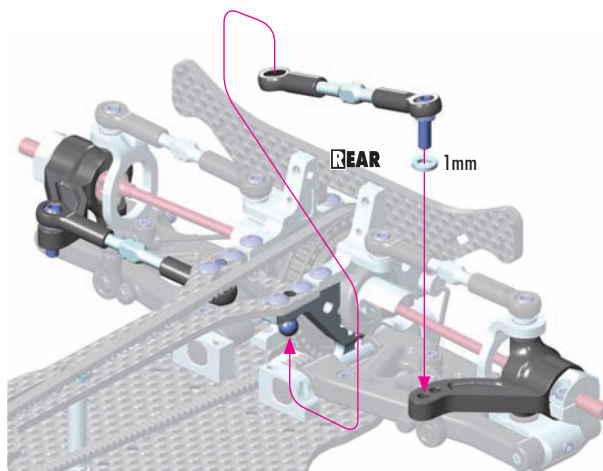

The link is mounted from the top of the steering block to the bulkhead. With this setting, the toe-in increases when the car is pressed. This means that if you set the toe-in to 3°, then when the car enters the corner, the toe-in increases which increases rear traction and stability but generates more push. Recommended for low-medium traction conditions.

By adding more shims on the top of the steering block, the toe-in is more increasing under pressing the car.



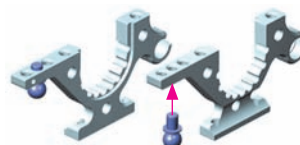

When using the ARS mounting alternative, mount the ball joints to the bulkheads before mounting the bulkheads to the chassis.



The optional ARS aluminum C-hubs were redesigned to work with the new T4'20 rear suspension geometry and are available in 0° | 2° | 4° caster.

#### ALU C-HUB ACTIVE REAR SUSPENSION™

	<p>0° C-hub is recommended for high-traction conditions as it generates greater off-power steering, rotation and cornering speed.</p>
	<p>2° C-hub angled toward the front of the car helps to generate more traction but in the same time generates more off-power steering and cornering speed compared to standard rear suspension. Recommended for medium-traction conditions.</p>
	<p>4° C-hub angled toward the front of the car generates maximum traction. Recommended for very-low-traction conditions. As the wheelbase will be shortened a lot with this setting, it is recommended to lengthen the rear wheelbase by moving the rear arms fully back.</p>

The effect of the toe-in change can be checked on a set-up station. Set the desired toe-in, then press the car to the ground and check how much the toe-in changes and in which direction.

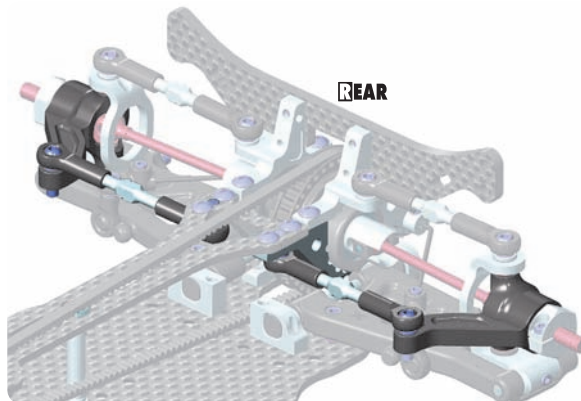
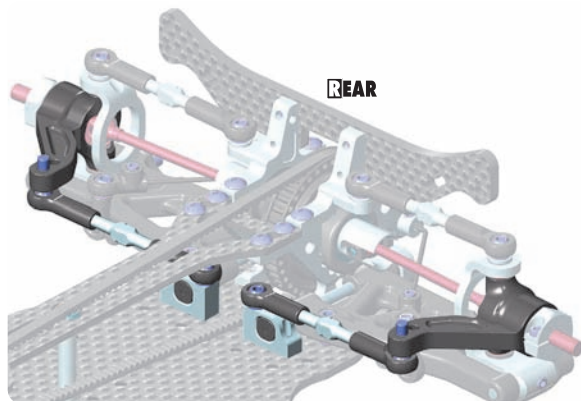



306219  
SHIM 3x6x1



901310  
SB M3x10



901408  
SB M4x8



903306  
SFH M3x6



## SHORT FRONT SUSPENSION ARMS ALTERNATIVE

It is possible to mount the short front suspension. You need to use the old suspension holders and mounted on the marked positions.

The front short arms can be used on a small technical track with high traction.

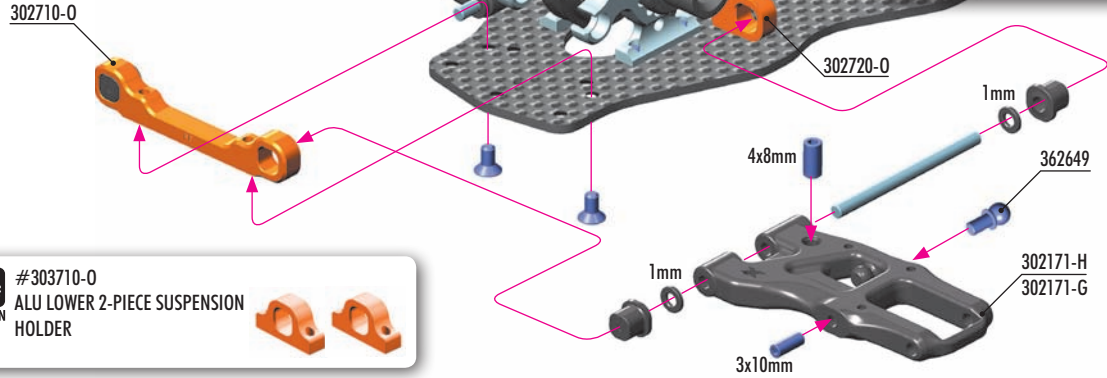

#303710-0  
ALU LOWER 2-PIECE SUSPENSION  
HOLDER



#302712-0 ALU FRONT 1-PIECE SUSPENSION HOLDER (FF-LOW)  
#302722-0 ALU FRONT 1-PIECE SUSPENSION HOLDER (FR-LOW)



#302711 BRASS FRONT 1-PIECE SUSPENSION HOLDER - FRONT - FF  
#302721 BRASS FRONT 1-PIECE SUSPENSION HOLDER - REAR - FR



### FRONT ARMS - SHORT

#302171-H	HARD	OPTION
#302171-G	GRAPHITE	OPTION



306219  
SHIM 3x6x1



901310  
SB M3x10



901408  
SB M4x8



903306  
SFH M3x6



## SHORT REAR SUSPENSION ARMS ALTERNATIVE

It is possible to mount the short rear suspension arms from previous T4 versions. You need to use the old RR suspension holder and move the RF block to the outside holes on the chassis.

The rear short arms can be used on a small technical track with high traction.

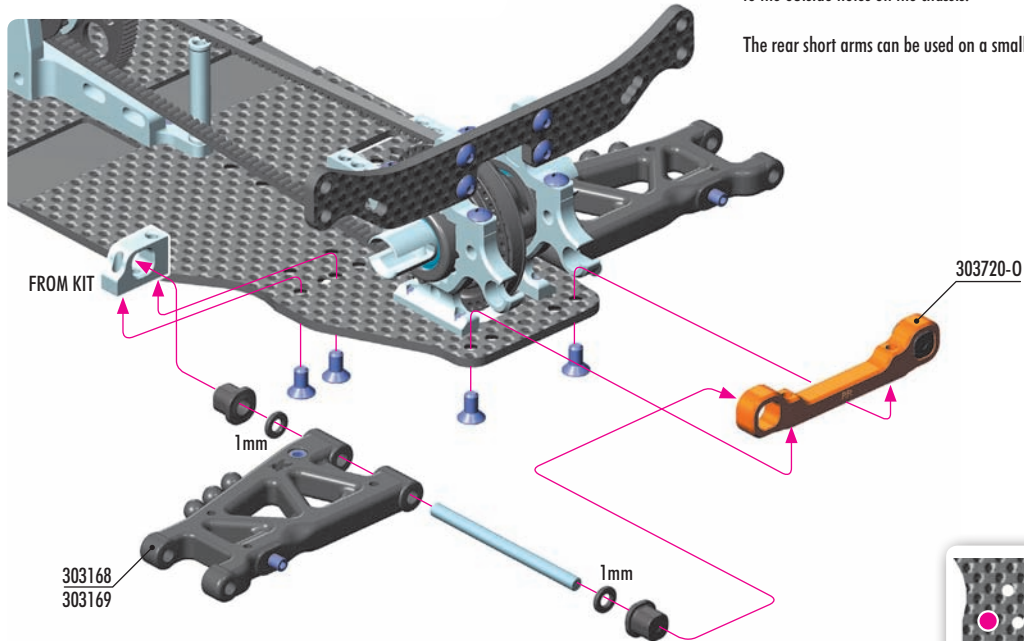

#303721  
BRASS REAR 1-PIECE SUSPENSION HOLDER - REAR - RR



### REAR ARMS - SHORT

#303168	HARD	OPTION
#303169	GRAPHITE	OPTION







303129  
SHIM 3x6x1



306219  
SHIM 3x6x3



902306  
SFH M3x6



903306  
SFH M3x6



903310  
SFH M3x10



### FLOATING FORWARD MOUNT SERVO HOLDER

Optional floating forward mount servo holder set allows mounting of the servo holder to the chassis more forward which leads to increased steering response and steering response.

Recommended for conditions where better steering response is needed. Makes the car more reactive but less stable.

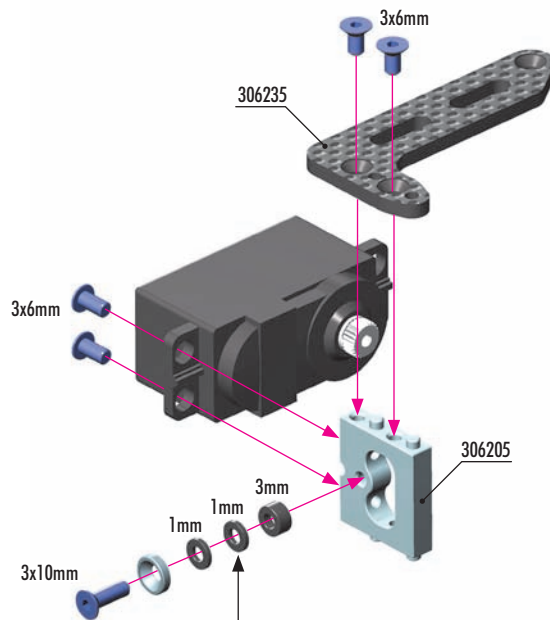

**!** The thickness of the shim may be changed depending on the position of the batteries you want to use.

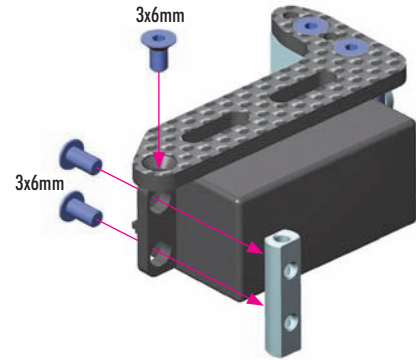

903306  
SFH M3x6

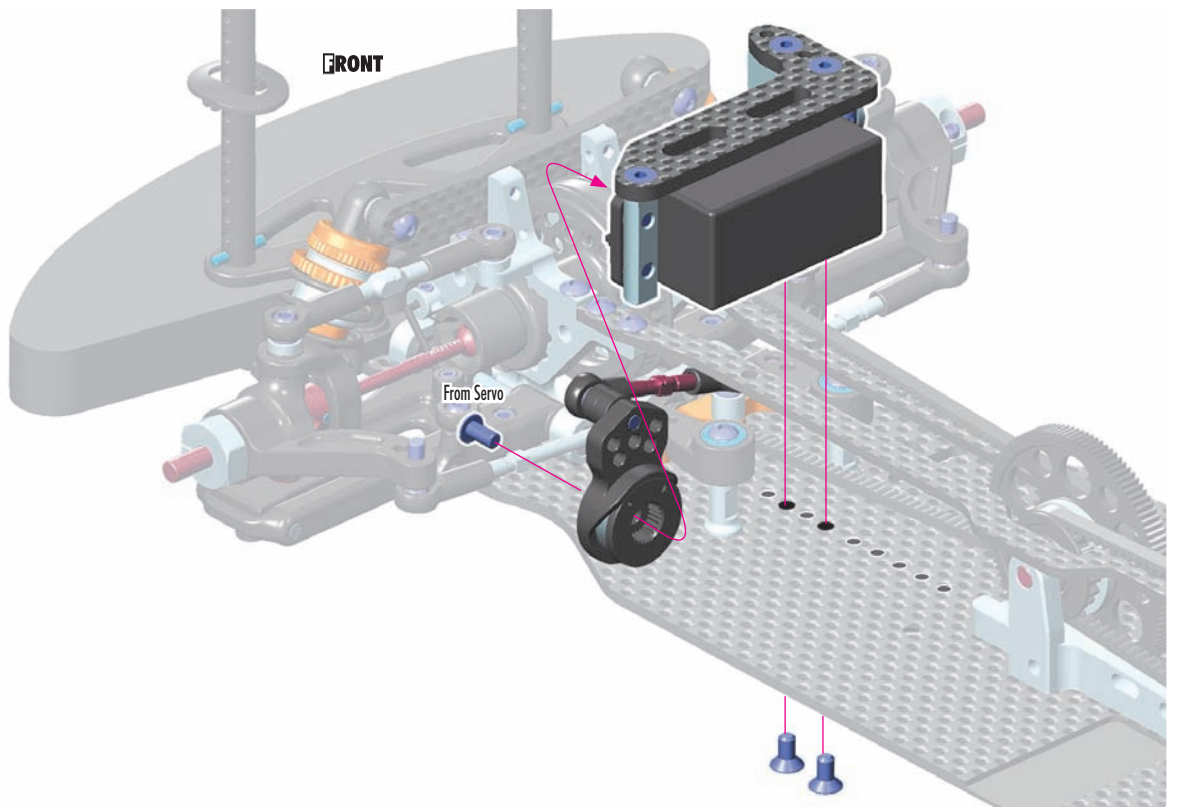

**IO**  
306219  
SHIM 3x6x1

**IO**  
306219  
SHIM 3x6x2

**902306**  
SH M3x6

**902310**  
SH M3x10



**OPTION ULP LOWER SHOCK TOWER FOR LOWER SHOCK MOUNTING – FRONT**

The new feature of the T4'20 arms is to mount the shocks lower. To use this option you need to use optional low ULP shock towers which allows you to mount shocks 4mm lower to lower the CG.

With the lower shock mounting, the car is more stable as it rolls less, is easier to drive over chicanes, and has improved steering response. Recommended for medium-high technical tracks, especially for carpet.



#301961  
**T4'20 ULP GRAPHITE SHOCK TOWER FRONT 3.0MM - LOWER**

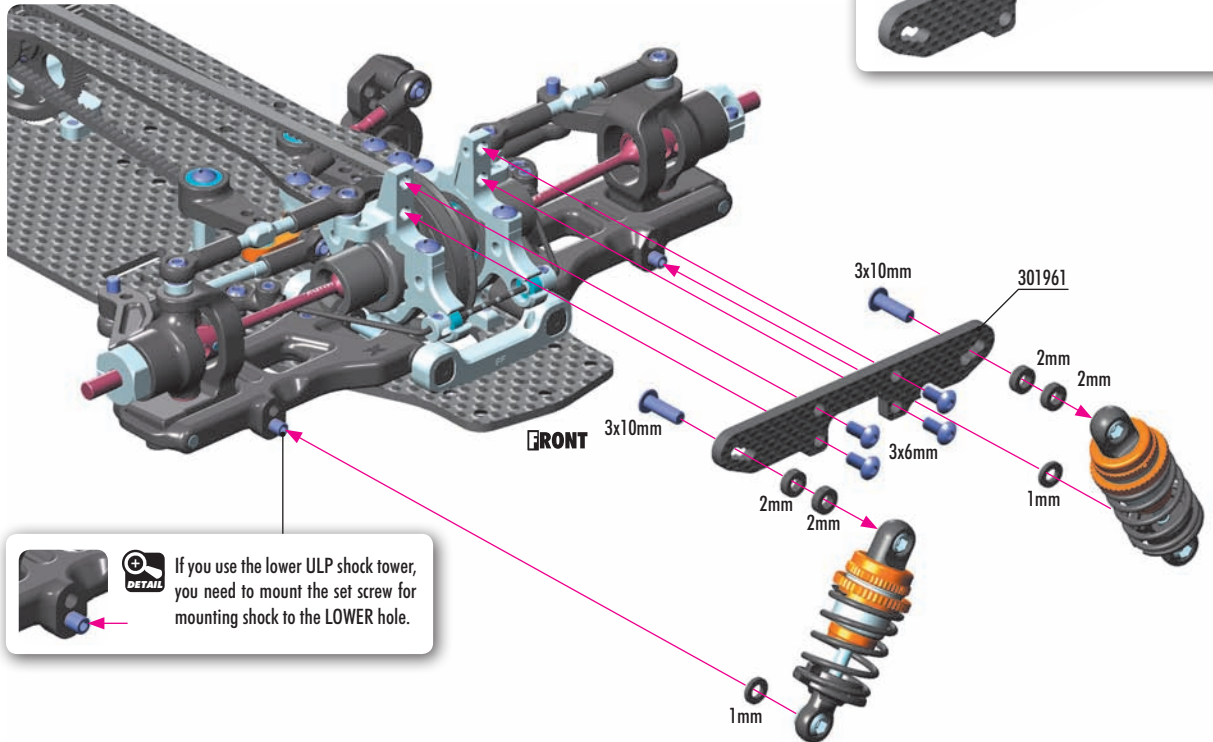

**DETAIL** If you use the lower ULP shock tower, you need to mount the set screw for mounting shock to the LOWER hole.

**IO**  
306219  
SHIM 3x6x1

**IO**  
306219  
SHIM 3x6x2

**902306**  
SH M3x6



**OPTION ULP LOWER SHOCK TOWER FOR LOWER SHOCK MOUNTING – REAR**

The new feature of the T4'20 arms is to mount the shocks lower. To use this option you need to use optional low ULP shock towers which allows you to mount shocks 4mm lower to lower the CG.

With the lower shock mounting, the car is more stable as it rolls less, is easier to drive over chicanes, and has improved steering response. Recommended for medium-high technical tracks, especially for carpet.



If you use ULP lower graphite shock tower, you need to move the body post one hole higher.

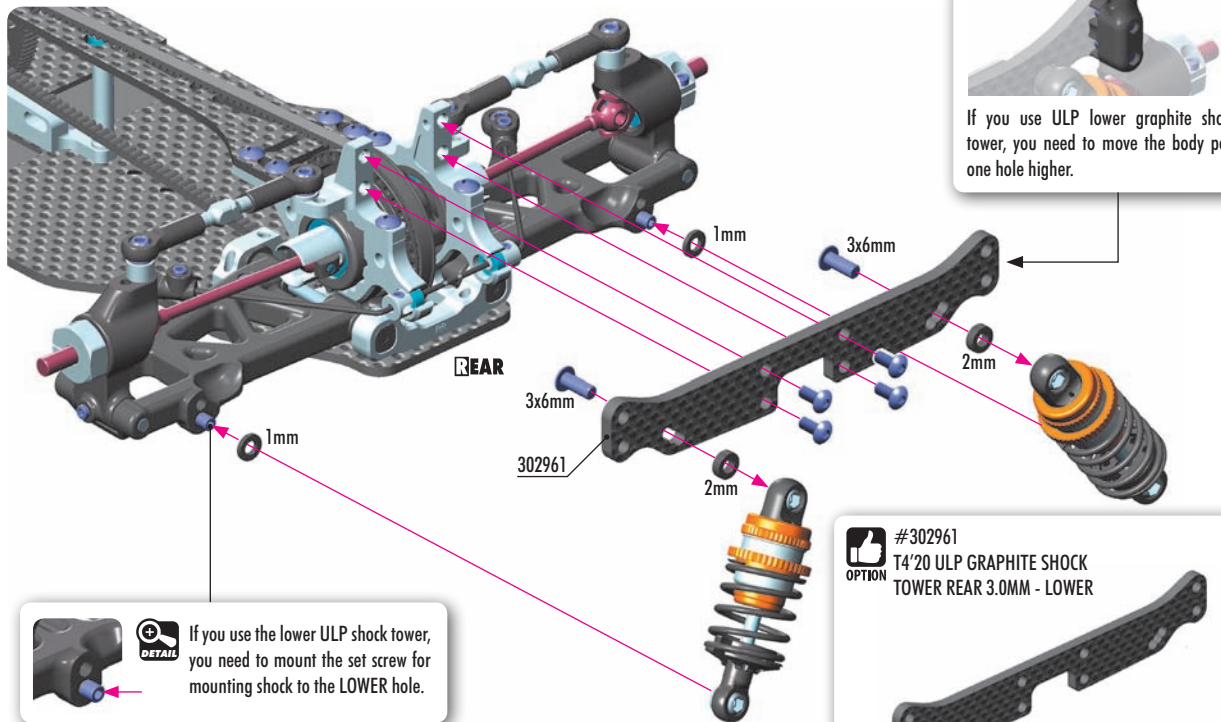

**DETAIL** If you use the lower ULP shock tower, you need to mount the set screw for mounting shock to the LOWER hole.



#302961  
**T4'20 ULP GRAPHITE SHOCK TOWER REAR 3.0MM - LOWER**





303121-K  
SHIM 3x6x0-5

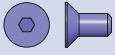

903306  
SFH M3x6

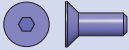

903308  
SFH M3x8

**CHASSIS BRACE**  
OPTION

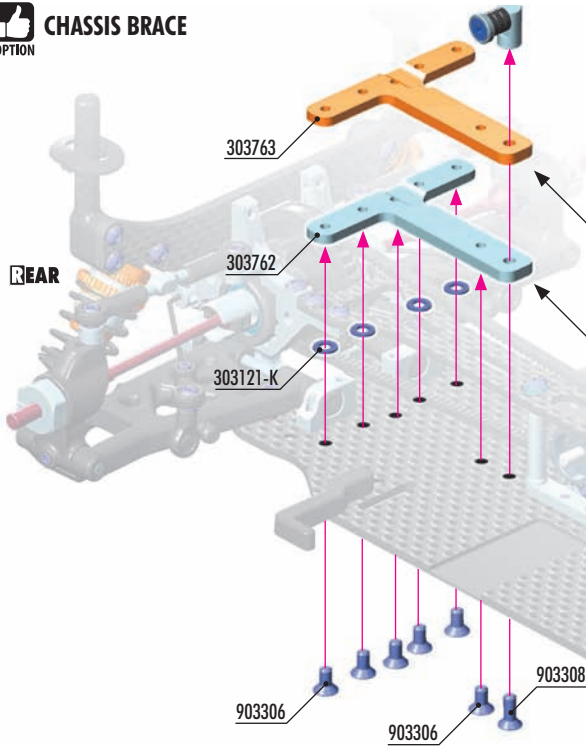

For further chassis flex adjustment the optional chassis brace can be mounted to the chassis.

The brace can be used with both graphite and aluminum chassis.

THERE ARE TWO BRACE ALTERNATIVES:

**BRASS** - which works also as an extra 15g weight which is recommended for high to very-high traction conditions.

**ALUMINUM** - recommended for low-medium-high traction conditions.



**NOTE ORIENTATION**

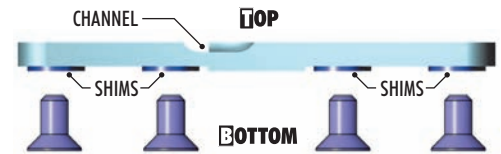

THE BRACE ALLOWS GREAT CHASSIS FLEX ADJUSTMENT POSSIBILITIES DEPENDING ON WHICH SCREWS ARE CONNECTED

**SOFT**

Install only the first two screws as shown. Improves on-power stability.

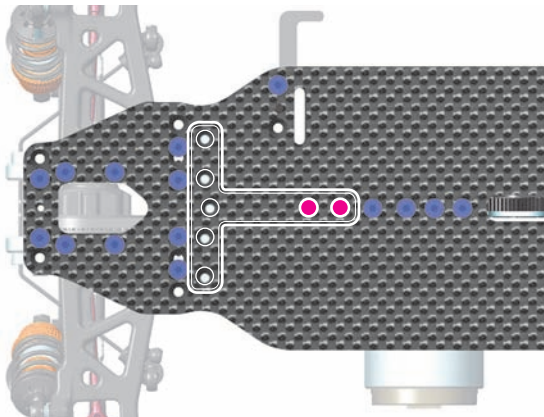

**MEDIUM**

Install all screws along chassis center line. Generates more stability and traction.

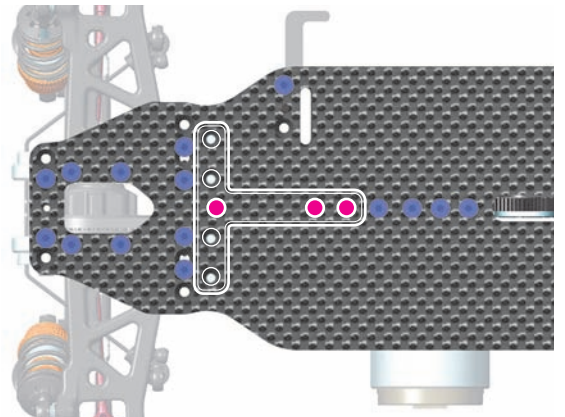

**STIFF**

Install all screws along center line plus inner side holes. Generates more off-power steering and rotation.

**IMPORTANT!**

When installing screws on the sides, add shims between the brace and the chassis.

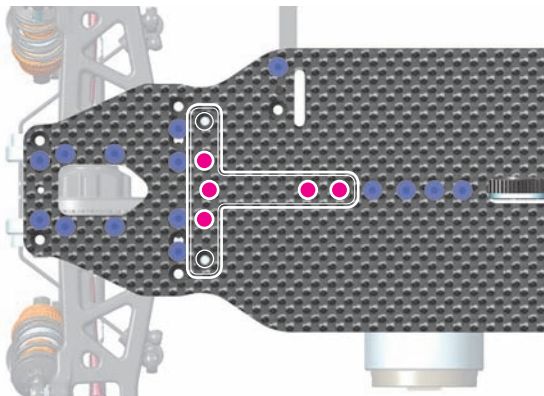

**EXTRA STIFF**

Install brace with all 7 screws. Recommended for high-traction conditions, gives a lot of off-power steering and rotation.

**IMPORTANT!**

When installing screws on the sides, add shims between the brace and the chassis.

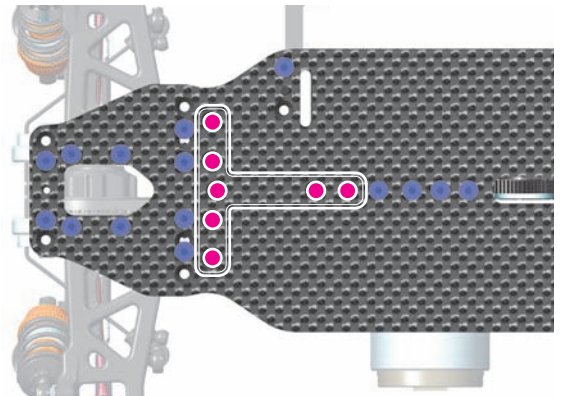

EXCLUSIVE PROFESSIONAL

# HUDY

108201

108205

108203

199911

107865

107771

107712

107714

107719

107715

107713

107716

107702

181110

293110

293111

181040

181030

181034

107905

104002

109800

183000

199181

- 104002 HUDY AIR VAC - VACUUM PUMP - ON-ROAD
- 106260 HUDY TIRE ADDITIVE - TIRE GRIPPER - 50ML - V2
- 107090 HUDY BEARING CHECKING TOOL
- 107601 LIMITED EDITION - REAMER FOR BODY 0-9MM + COVER - SMALL
- 107643 LIMITED EDITION - ARM REAMER # 3.0MM
- 107702 CHASSIS DROOP GAUGE SUPPORT BLOCKS FOR 1/10 (2)
- 107712 CHASSIS DROOP GAUGE -3.0-10MM FOR 1/10 CARS (10MM)
- 107713 CHASSIS RIDE HEIGHT GAUGE STEPPED 2.0-15.0MM
- 107714 ULTRA-FINE CHASSIS DROOP GAUGE 4.0-6.6MM
- 107715 CHASSIS RIDE HEIGHT GAUGE 1.0-15.0MM (BEVELED)
- 107716 ULTRA-FINE CHASSIS RIDE HEIGHT GAUGE 3.8-8.0MM
- 107719 QUICK DOWNSTOP GAUGE TOOL 1.0-6.5MM

- 107720 CHASSIS RIDE HEIGHT GAUGE 30-17MM FOR 1/8 & 1/10 OFF-ROAD
- 107750 HUDY GRAPHITE QUICK CAMBER GAUGE 1.5°, 2°, 2.5° FOR 1/10 TC
- 107771 HUDY BODY GAUGE 1/10 ELECTRIC TOURING CARS
- 107855 HUDY PIT LED
- 107865 HUDY PROFESSIONAL DIGITAL POCKET SCALE 300G/0.01G
- 107870 HUDY FIBRE-REINFORCED TAPE - BLACK
- 107875 HUDY ULTRA DOUBLE-SIDED TAPE
- 107880 CHASSIS BALANCING TOOL (2)
- 107904 HUDY QUICK-TWEAK STATION 1/10 & 1/12 ON-ROAD
- 107905 HUDY TWEAK BOARD SET
- 108150 HUDY 1/10 TOURING CAR STAND - V3
- 108190 HUDY ALU TRAY FOR PARTS

- 108201 FLAT SET-UP BOARD FOR
- 108203 FLAT SET-UP BOARD FOR
- 108205 FLAT SET-UP BOARD FOR
- 109305 UNIVERSAL EXCLUSIVE SE
- 109360 ALU NUT FOR 1/10 TOURI
- 109370 ALU SET-UP WHEEL FOR 1
- 109800 HUDY ALU TRAY FOR ON-R
- 109840 HUDY ALU TRAY FOR 1/10
- 109860 HUDY ALU TRAY FOR SET-
- 109880 HUDY ALU TRAY FOR ACCE
- 111545 LIMITED EDITION - ALLEN
- 112045 LIMITED EDITION - ALLEN



107855  
 109880  
 109840  
 109305  
 109370  
 108190  
 188981  
 188990

113045 LIMITED EDITION - ALLEN WRENCH # 3.0MM  
 132045 LIMITED EDITION - ALLEN WRENCH + BALL REPL. TIP # 2.0MM  
 175535 LIMITED EDITION - SOCKET DRIVER # 5.5MM  
 177035 LIMITED EDITION - SOCKET DRIVER # 7.0MM  
 181030 HUDY SPRING STEEL TURNBUCKLE WRENCH 3 MM  
 181034 TURNBUCKLE WRENCH 3 & 4MM - HUDY SPRING STEEL™  
 181040 TURNBUCKLE WRENCH 4MM - HUDY SPRING STEEL™  
 181110 HUDY BALL JOINT WRENCH  
 183000 HUDY PROFESSIONAL BULKHEAD ALIGNMENT TOOL 19MM  
 183011 HUDY PROFESSIONAL MULTI TOOL  
 188981 HUDY POCKET HOBBY KNIFE  
 188990 HUDY PROFESSIONAL BODY SCISSORS

107904  
 106260  
 199270  
 109060  
 298100  
 108150  
 107875  
 107870  
 183011  
 107090  
 107601  
 107643  
 177035  
 175535  
 111545  
 132045  
 112045  
 113045

For more information about tools, set-up equipment and accessories suitable for your car please visit:

[www.hudy.net](http://www.hudy.net)





[www.teamxray.com](http://www.teamxray.com)

**XRAY EUROPE**

XRAY, K VÝSTAVISKU 6992, 91101 TRENCIN, SLOVAKIA, EUROPE  
 PHONE: +421-32-740 11 00, FAX: +421-32-740 11 09, [info@teamxray.com](mailto:info@teamxray.com)

**XRAY USA**

RC AMERICA, 2030 Century Center Blvd #15, Irving, TX 75062, USA  
 PHONE: 214-744-2400, FAX: 214-744-2401, [xray@rcamerica.com](mailto:xray@rcamerica.com)

