

RC10
BE4
TEAM KIT

**1:10 Scale 2WD Electric Off Road
Competition Buggy Kit**



#90034 RC10BE4 TEAM KIT



1:10 Scale 2WD Electric Off Road Competition Buggy Manual

WEAREAE
CHAMPIONS *by* **DESIGN**
AssociatedElectrics.com

TEAM ASSOCIATED

:: Introduction

Thank you for purchasing this Team Associated product. This assembly manual contains instructions and tips for building and maintaining your new vehicle. Please take a moment to read through the manual and familiarize yourself with the steps. We are continually changing and improving our designs; therefore, actual parts may appear slightly different than the illustrations. New parts will be noted on supplementary sheets located in the appropriate parts bags. Check each bag for these sheets before you start to build.

:: RC10B6.4 KIT Features

- New 13mm big-bore threaded aluminum shocks and springs with machined shock pistons for improved bump and jump handling
- New +3mm length aluminum chassis with 22.5° kick-up to complement updated front-end geometry and with new shape to reduce chassis scrub with the track surface
- 20°, 22.5°, and 25° molded bulkheads included for a complete range of caster and kickup options
- New adjustable height steering bellcrank and rack system for optimized bumpsteer at all ride heights and caster angles
- New -1mm kingpin offset steering and caster block set for smoother and more predictable steering through the entire wheel throw
- New steel RC10B6.4 ESC mounting tray shifted forward in the chassis and with a wider footprint to fit electronics, resulting in a further forward weight bias
- New front ballstud mount, top plate, and front wing mount to account for the kickup angle change
- New chassis side rails with 3 optional fan mount locations to choose from depending on chassis length and transmission used
- New cab-forward design RC10B6.4 bodyshell offered in standard (kit) and lightweight (optional) thickness
- Front and rear anti-roll bars included
- Front wing mount and front wing included
- Clear body and clear wing included
- 5mm aluminum clamping rear wheel hexes
- 4mm carbon fiber front and rear shock towers with molded protective covers

:: Additional

Your new B6.4 Team Kit comes unassembled and requires the following items for completion (Refer to www.rc10.com and www.Reedypower.com for complete listings):

- RC two channel surface frequency radio system
- AA-size batteries for transmitter (#302 alkaline)
- Electronic Speed Control, ESC
- Steering servo
- 540 size electric motor
- Pinion gear (48P), size determined by type/wind of motor
- Battery charger (a peak detection charger, or LiPo compatible charger)
- 2 cell LiPo battery pack
- Polycarbonate specific spray paint
- Cyanoacrylate glue (CA) (#1597)
- Thread locking compound (#1596)
- Tires and Inserts, Fronts and Rears
- Wheels w/12mm Hex
Front Wheels #9690, #9691
Rear Wheels #9695, #9696
- Slim Front Wheels w/12mm Hex (carpet/astro use)
#91757 (white) #91758 (yellow)

:: Other Helpful Items

- Silicone Shock Fluid (Refer to www.rc10.com for complete listings):
- Body Scissors (AE Part #1737)
- FT Hex/Nut Wrenches (AE Part #1519, 1650)
- Green Slime shock lube (AE Part #1105)
- Soldering Iron
- Needle Nose Pliers
- FT Body Reamer
- FT Ballcup Wrench (#1579)
- FT Dual Turnbuckle Wrench (#1114)
- Hobby Knife
- Shock Pliers
- FT Universal Tire Balancer (#1498)
- Calipers or a Precision Ruler
- Wire Cutters

















Associated Electrics, Inc.
21062 Bake Parkway
Lake Forest, CA 92630











Customer Service
Tel: 949.544.7500
Fax: 949.544.7501

:: Hardware - 1:1 Scale View





Button Head (bhcs)

	2x4mm (31510) Aluminum (8545)
	2.5x6mm (31520)
	2.5x8mm (31521)
	2.5x10mm (31522)
	3x4mm (91158)
	3x5mm (31530)
	3x6mm (31531)
	3x8mm (31532)
	3x10mm (25211)
	3x12mm (89202)
	3x14mm (25187)
	3x16mm (89203)
	3x18mm (2308)
	3x20mm (25188)
	3x22mm (25189)
	3x24mm (89204)
	3x30mm (91478)



Flat Head (fhcs)

	2x3mm (91749)
	2.5x8mm (31448)
	3x8mm (25201)
	3x10mm (25202)
	3x12mm (25203)
	3x14mm (89208)
	3x16mm (25204)
	3x18mm (89209)





Set Screws

	3x2.5mm (31500)
	3x3mm (25225)
	3x5mm (89219)
	3x10mm (4671)
	3x20mm (91737)





Socket Head (shcs)

	1.6 x 5mm (91611)
	3 x 18mm (25191)
	3 x 6mm (41089)
	3 x 22mm (41095)









Shims and Washers

	5.5x0.5mm (31381)
	5.5x1.0mm (31382)
	5.5x2.0mm (31383)
	2.6x6mm Washer (89278)
	3x8mm Washer (89218)

Ball Bearings

	4x7x2.5mm (31732)
	5x8x2.5mm (8680)
	5x10x4mm (91560)
	5x12x4mm (91567)
	10x15x4mm (91563)





Ballstuds

	Silver 5mm long (31283)
	Silver 8mm long (31284)
	HD 6mm (91047)
	Ti HD 6mm (91751)
	HD 8mm (91048)
	Ti HD 8mm (91752)
	HD 10mm (91049)
	Ti HD 10mm (91753)

Nuts (lock/plain)

	M3 Plain Nut (91477)
	M3 Alum. Locknut, Blue (31550)
	M3 Locknut, Black (25215)
	M3 Locknut w/Flange (25612)
	FT 3mm Locknuts, Blue(25392)
	M4 Nuts:
	Serrated Steel (Silver)(91826)
	FT Alum. Locknut (Blue) (25391)
	Serrated Steel (Black) (91738)
	Serrated Steel LP (Black) (91150)

Diff Balls

	3/32 Carbide Diff Balls (6581)
	3/32 Ceramic Diff Balls (6584)
	Thrust Washer (91990)
	Caged Thrust Washer (91990)

Notes:

:: Table of Contents

1..... Cover	14.....Bag 7: Rear Hubs
2..... Introduction	15.....Bag 8: Turnbuckles
3.....1:1 Hardware "Fold Out"	16 - 18.....Bag 9: Shocks
4..... Table of Contents	19 - 23.....Bag 10: Battery Strap, Body, and Wheels
5.....Bag 1: Steering	24 - 25..... Tuning Tips
5 - 8.....Bag 2: Front Suspension	26..... Back Cover
8 - 9.....Bag 3: Caster Blocks	
9 - 10.....Bag 4: Rear Suspension	
10 - 11.....Bag 5: Gear Diff	
11 - 13.....Bag 6: Gearbox	

:: Notes

This symbol indicates a special note or instruction in the manual.



This symbol indicates a Racers Tip.



There is a 1:1 hardware foldout page in the front of the manual. To check the size of a part, line up your hardware with the correct drawing until you find the exact size. Each part in the foldout has a number assigned to it for ordering replacement parts.

**Associated Electrics, Inc.
21062 Bake Parkway
Lake Forest, CA 92630**



**Customer Service
Tel: 949.544.7500
Fax: 949.544.7501**

:: Bag 1 - Step 1

!
Note orientation of steering rack.

31732 Σ 4
4 x 7 x 2.5 Ball Bearing

91973 Steering Bellcrank (Right)

31283 5mm Ball Stud, Long

91973 Steering Bellcrank (Left)

91973 Steering Rack

91048 Σ 2
Heavy-duty Ballstud, 8mm

31382 Σ 2
FT Ballstud Washer, Aluminum (1mm)

89202 Σ 2
M3 x 12mm BHCS

91974 Σ 2
Steering Hat Bushing

Remove the steering rack washers for less steering

:: Bag 1 - Step 2

25191 Σ 2
M3 x 18mm SHCS

31732 Σ 4
4 x 7 x 2.5 Ball Bearing

91974 Σ 2
Steering Hat Bushing, High

B6.4 Kickup/Steering Option Chart				
Steering	Bulkhead	Caster Insert	Chassis	Total Insert
High	2.5°	0°	22.5°	25°
Low	2.5°	2.5°	22.5°	27.5°
Low	2.5°	5°	22.5°	30°
High	0°	0°	22.5°	22.5°
High	0°	2.5°	22.5°	25°
Low	0°	5°	22.5°	27.5°
High	-2.5°	0°	22.5°	20°
High	-2.5°	2.5°	22.5°	22.5°
High	-2.5°	5°	22.5°	25°

91049 Σ 2
Heavy-duty Ballstud, 10mm

31382 Σ 2
FT Ballstud Washer, Aluminum (1mm)

91971 Front Ball Stud Mount

! [Low position] Bellcranks down, hat side on top

! [High position] Bellcranks up, hat side on bottom

:: Bag 2 - Step 1

91979 Bulkhead (use 0°)

91968 B6.4 Chassis, +3mm

89208 Σ 2
M3 x 14mm FHCS

! Note: Check the screw length as both 14mm and 16mm are in the screw bag. Use the shorter of the two screws!

! There are two bulkheads included in the kit (0°, 2.5°). 0° is the standard used. The arrows on the 2.5° bulkhead should point forward for the desired setting.

ZERO

0

+2.5°

-2.5°

:: Bag 2 - Step 2

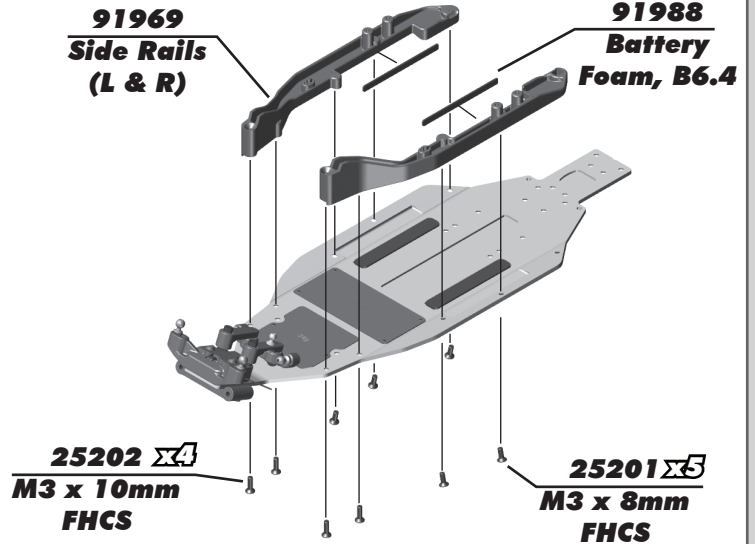
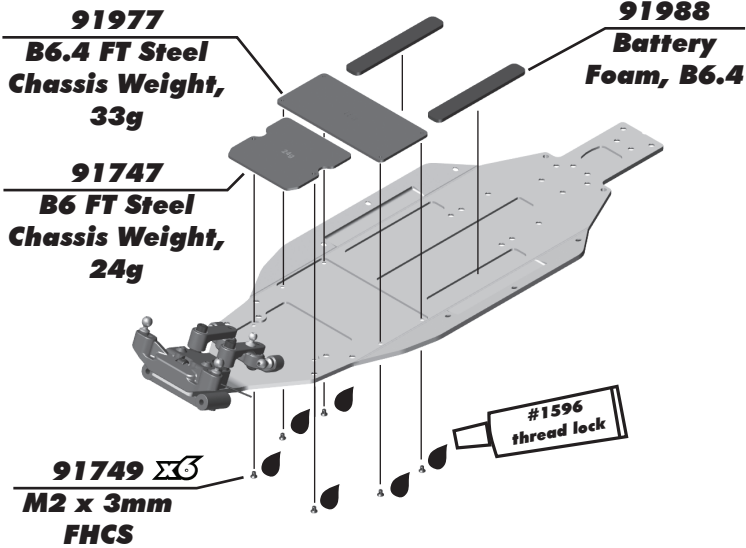

:: Bag 2 - Step 3

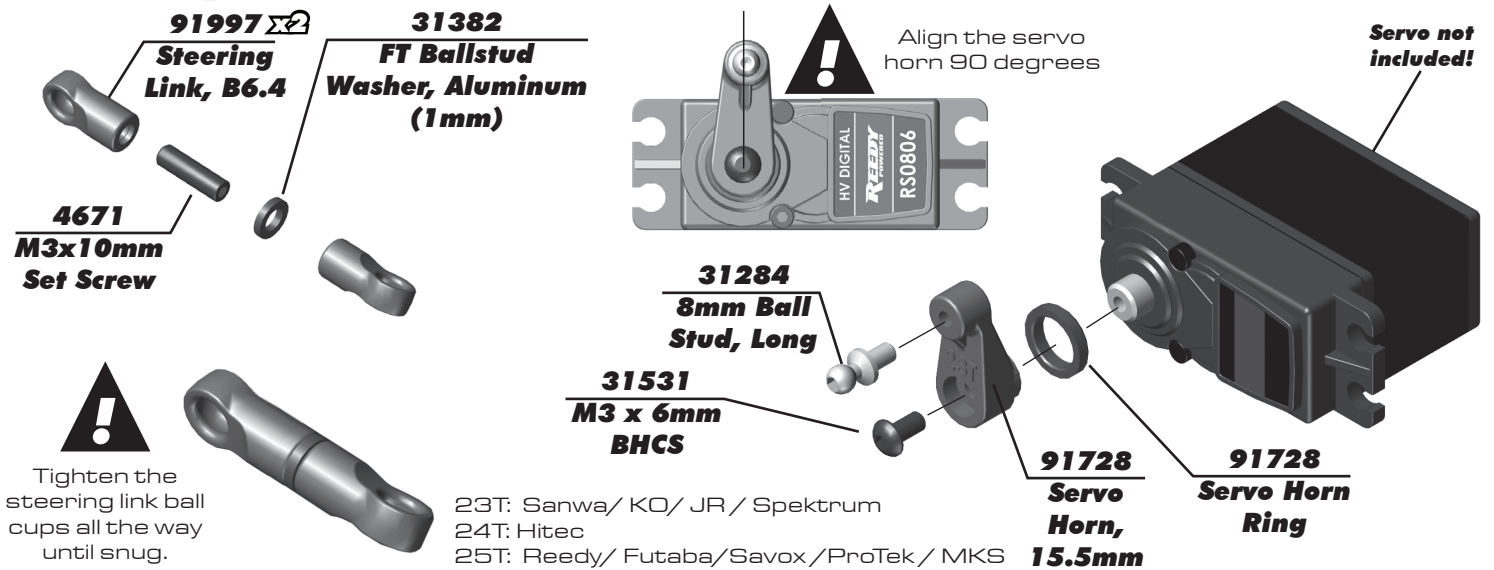

:: Bag 2 - Step 4

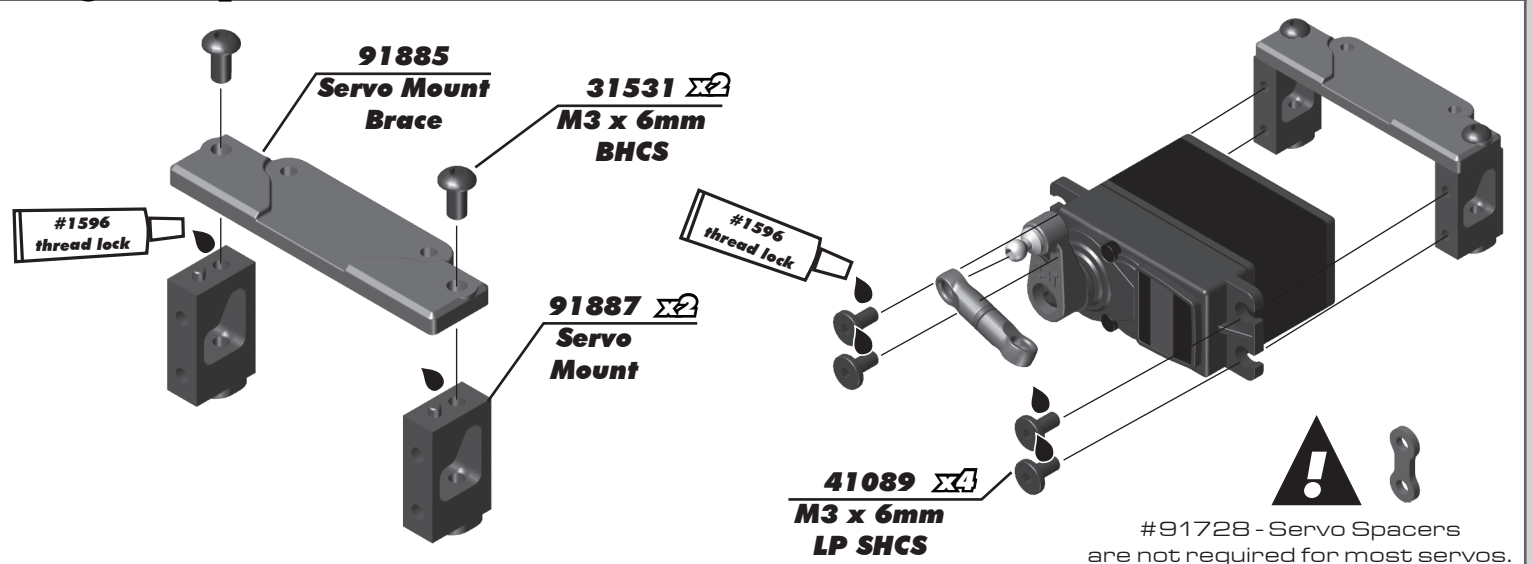

:: Bag 2 - Step 5

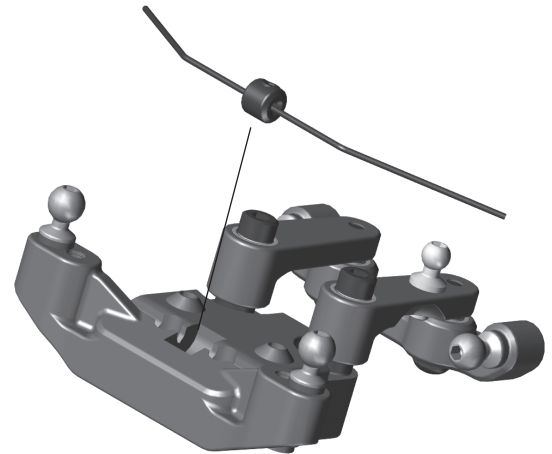
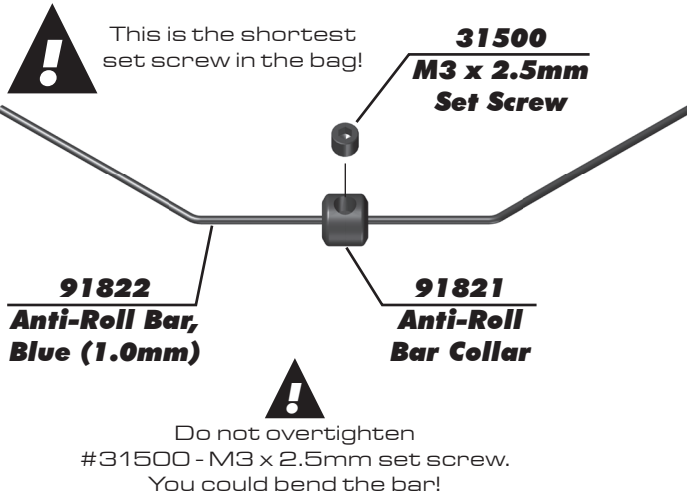

:: Bag 2 - Step 6

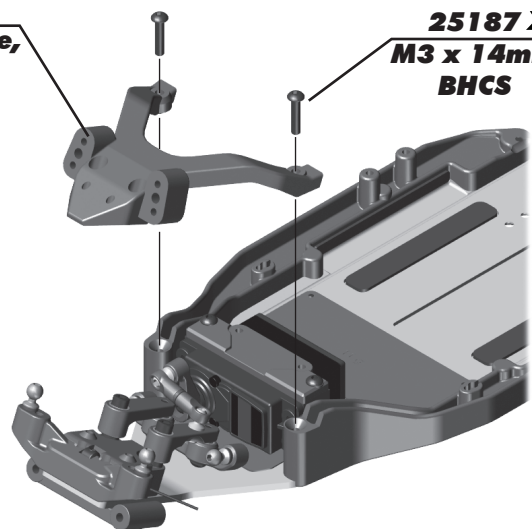
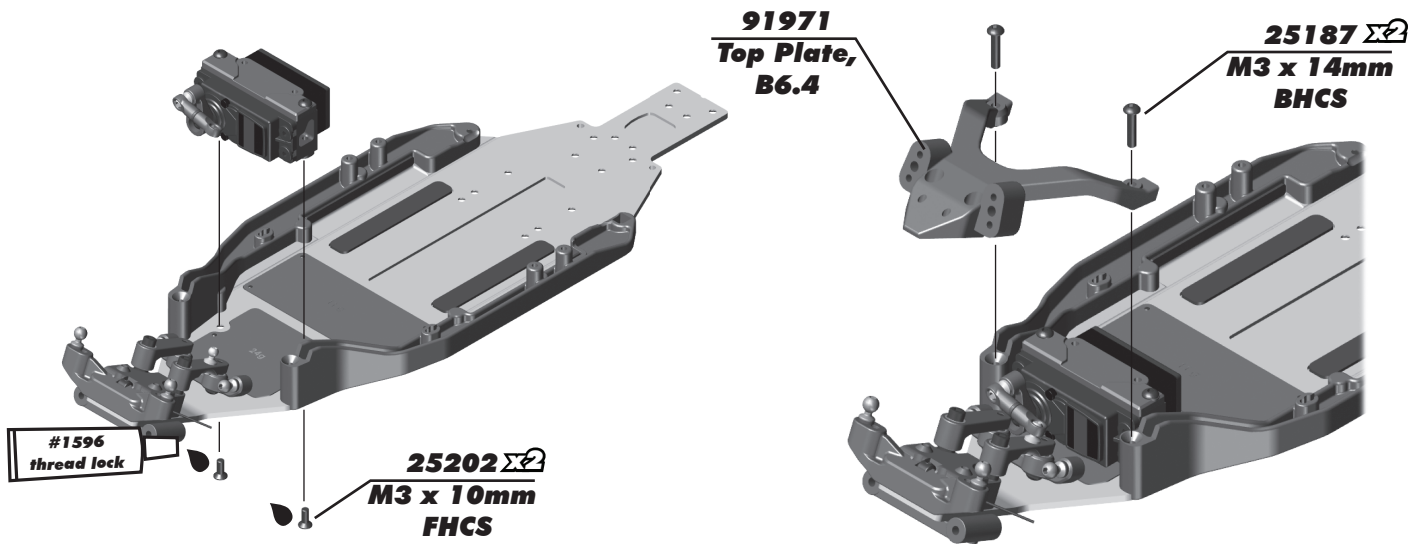

:: Bag 2 - Step 7

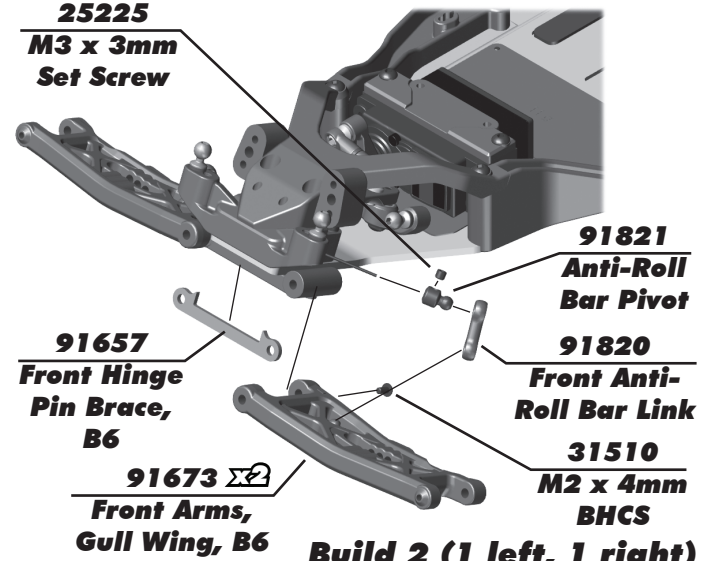
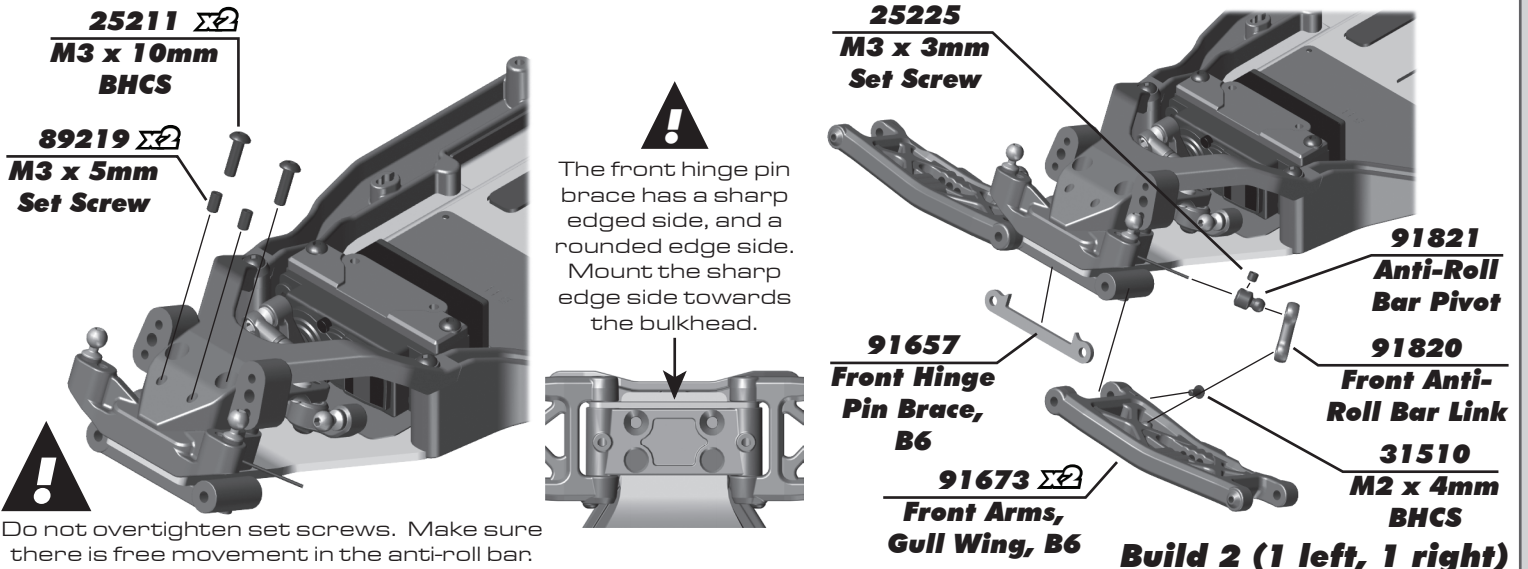

:: Bag 2 - Step 8

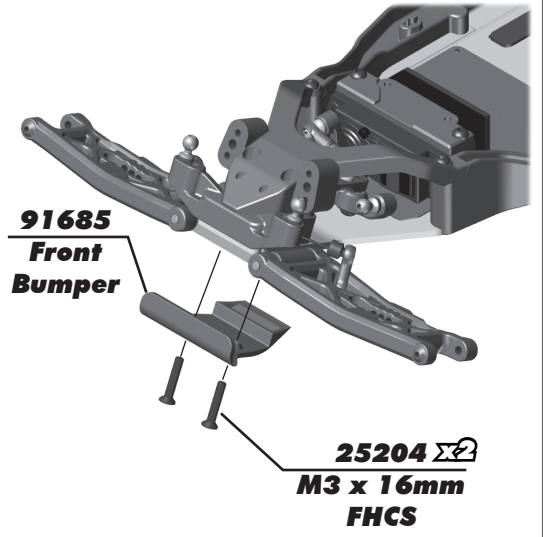
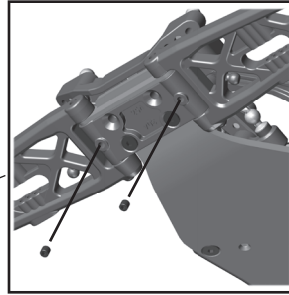
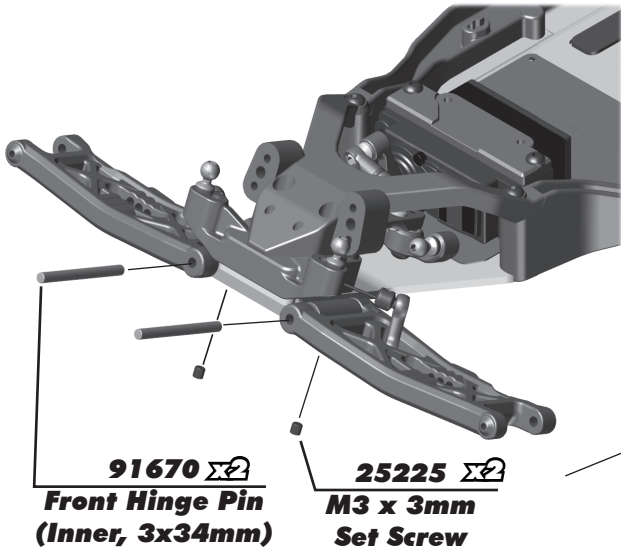

:: Bag 2 - Step 9



#91978 - Front Wing Mount is used as a tuning option to increase front end stability by adding a front wing (included).
If you do not use #91978, use #25202 M3x10mm FHCS instead of #89208 M3x14mm FHCS.

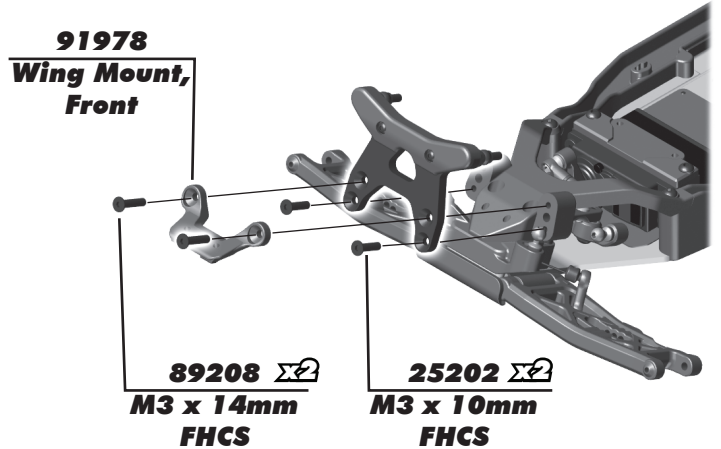
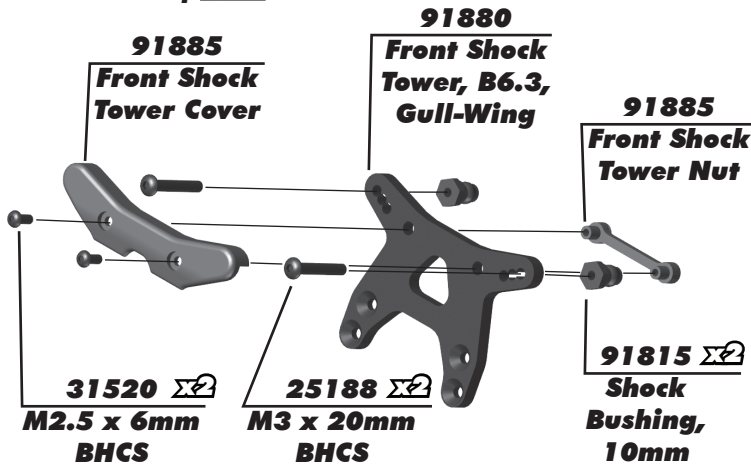

:: Bag 3 - Step 1

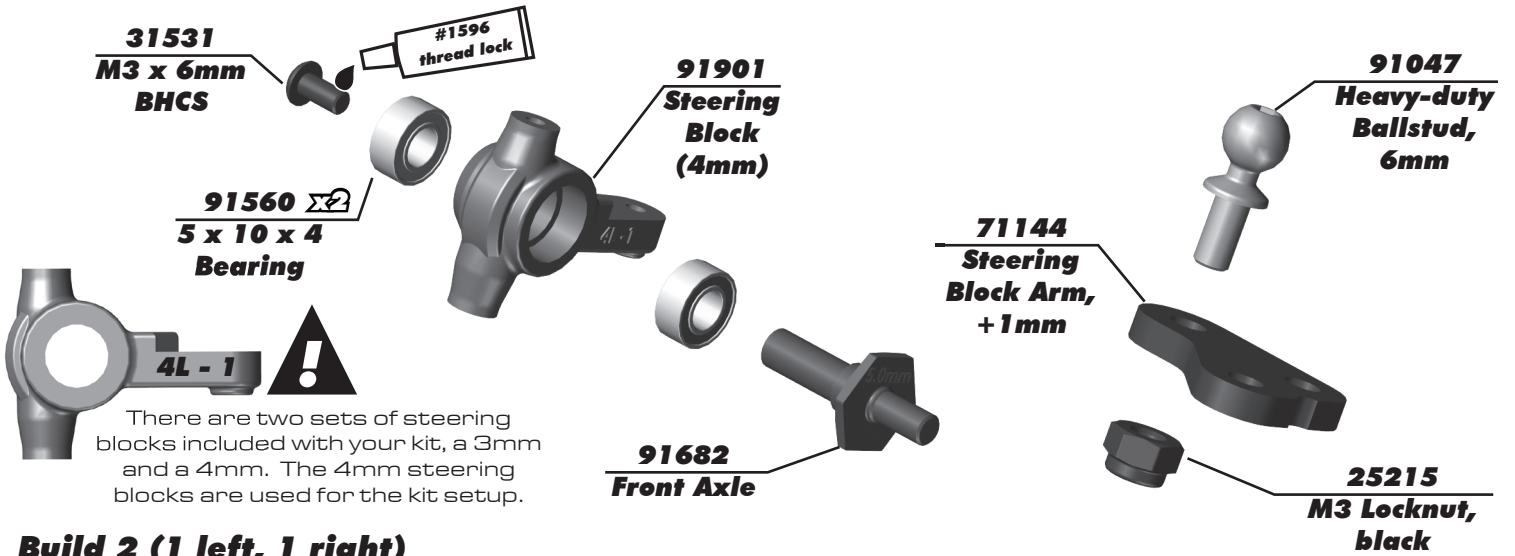

:: Bag 3 - Step 2



Use shorter screw in front!

31531
M3 x 6mm
BHCS

31532
M3 x 8mm
BHCS

91049
Heavy-duty
Ballstud,
10mm

91901
Caster
Block

25215
M3 Locknut,
black

You can install an optional #31520 screw to use as a steering stop setting.

You can install an optional #4670 set screw to better hold the caster block inserts and hinge pin.

91901
Caster
Block Insert
(2.5°)



There are three caster block inserts included [0°, +/-2.5°, +/-5°]. +2.5° is the standard insert used.

Tab up = positive caster
Tab down = negative caster

Build 2 (1 left, 1 right)

:: Bag 3 - Step 3

25187
M3 x 14mm
BHCS

91676 $\Sigma 2$
Caster Hat
Bushing
Top: 2mm
Bottom: 1mm

91776
Caster Block
Spacer

91670
Front Hinge Pin
(Outer, 3x26mm)

31510
M2 x 4mm
BHCS

89202
M3 x 12mm
BHCS

! #91670 - Hinge Pin will be tight in the caster blocks, but should rotate freely in the front arms.

Build 2 (1 left, 1 right)

Build 2 (1 left, 1 right)

:: Bag 4 - Step 1

Arm Mount C: 1° Out

91882
Aluminum
Arm Mount, C

92014 $\Sigma 2$
Arm Mount
Inserts
(1°)

! See next step for pill chart tips

#1596
thread lock

31541 $\Sigma 2$
M3 x 6mm
FHCS



You can use a dot of CA glue to better secure the lower shock mounting set screw



11mm

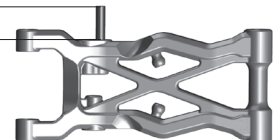

91737 $\Sigma 2$
M3 x 20mm
Set Screw

91853 $\Sigma 2$
B6.2 Rear
Arms, 73mm

Build 2 (1 left, 1 right)

:: Bag 4 - Step 2

**Arm Mount D:
Center**

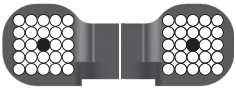

92014
**Arm Mount
Inserts (1°)**

91685
**Rear
Bumper**

91883
**Aluminum
Arm Mount, D**

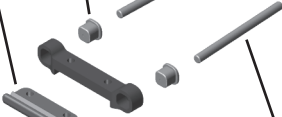
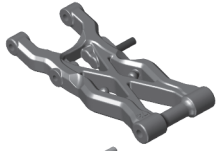

91670
**Rear Hinge Pin
(Inner, 3.5x48mm)**

91853
**Rear Arm
Spacer**



The (#91882) C and (#91883) D aluminum arm mounts allow for a large amount of setup combinations when using the (#92014) 0.5° and 1° arm mount inserts.

For a complete list of pill setup combinations, please visit our website by using the link below.
<http://bit.ly/B6PillChart>

	Toe-In	Anti-Squat
Arm Mount C: 1° Out		
Arm Mount D: Center	2° Kit Setup	1° Kit Setup

:: Bag 5 - Step 1

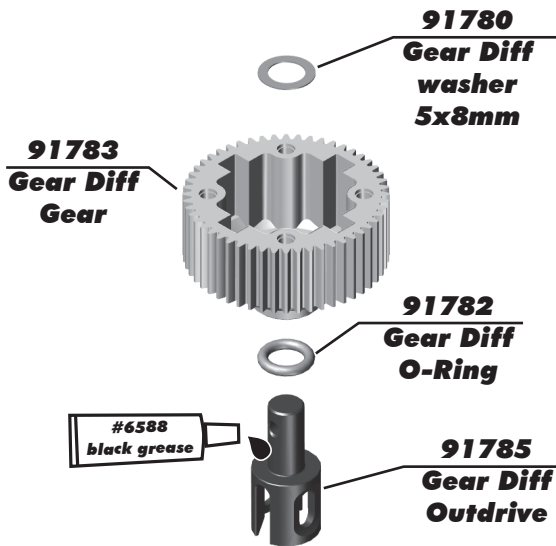

91780
**Gear Diff
Sun Gear**



91785
**Gear Diff
Outdrive
Pin**



One pocket is flat for inserting the #91785 gear diff outdrive pin.

:: Bag 5 - Step 2

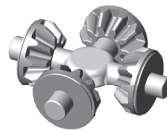
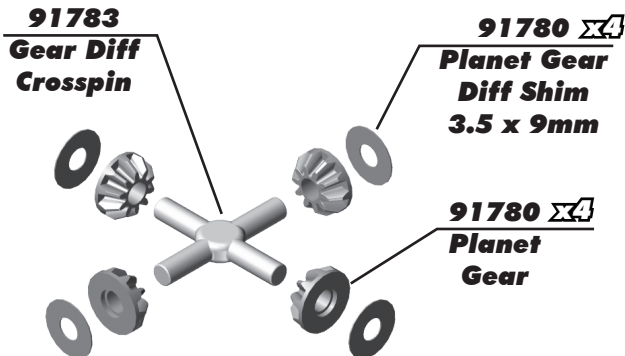

#91782 3.3x0.6mm Gear Diff O-Rings are a tuning option. Kit setup is built without O-Rings

:: Bag 5 - Step 3

91780
Gear Diff
Sun Gear

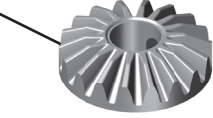

91785
Gear Diff
Outdrive
Pin

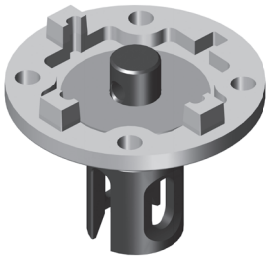

91782
Gear Diff
Gasket

31522 X4
M2.5 x 10mm
BHCS



Diff fluid
#5453



!
Fill to top of the
cross pins

:: Bag 6 - Step 1

91821
Anti-Roll
Bar Pivot



4671
M3 x 10mm
Set Screw



91997 X2
Steering Link
Ball Cup



!
Do not overtighten
#25225 - M3 x 3mm set
screw. You could bend the bar!

25225
M3 x 3mm
Set Screw

25225 X2
M3 x 3mm
Set Screw

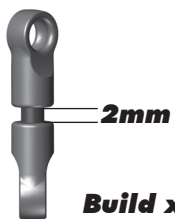
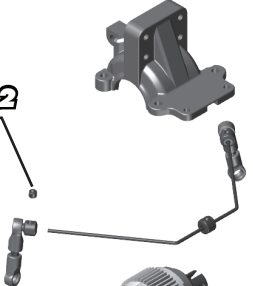

91823
Anti-Roll Bar,
Gray (1.3mm)

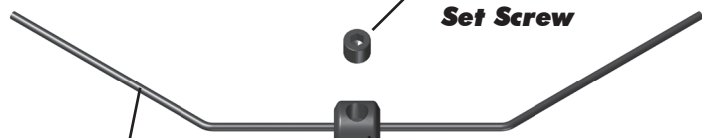

91821
Anti-Roll
Bar Collar

bar flush
with pivot

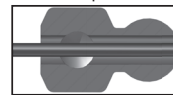

Build x2 (right and left side)

:: Bag 6 - Step 2

91799
B6.1 Laydown
Top Shaft

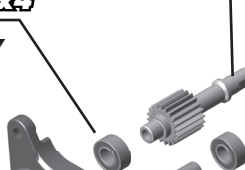

91791
B6.1 Laydown
Gearbox
(right & left)

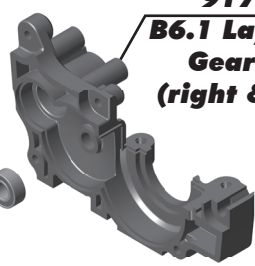

31472
2.5x8mm
FHCS

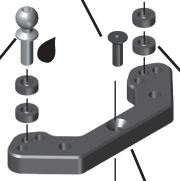

#1596
thread lock

91560 X4
5 x 10 x 4,
Bearing

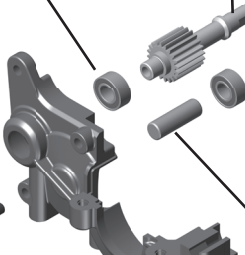

91048 X2
Heavy-duty
Ballstud, 8mm

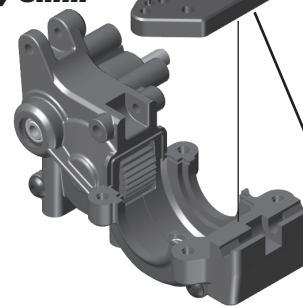

31383 X4
Ballstud
Washers,
5.5x2.0mm,
Blue Aluminum

91716
Idler Gear
39T

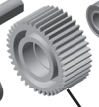

91132
Idler Gear
Shaft,
Aluminum

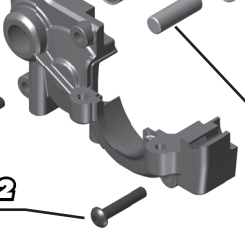

89203 X2
3x16mm
BHCS



91775
B6.1 Rear
Ballstud Mount,
Aluminum

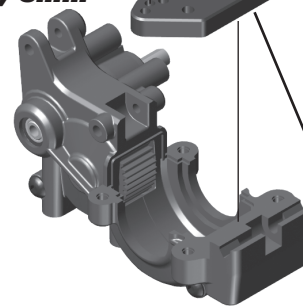

:: Bag 6 - Step 3

Diff Height	
	3 Kit Setup
	2
	1
	0



Add a drop of Diff Lube (#6591 - not included) to the teeth of the diff gear, idler gear, and top shaft.

91563 $\Sigma 2$
10x15x4 Bearing

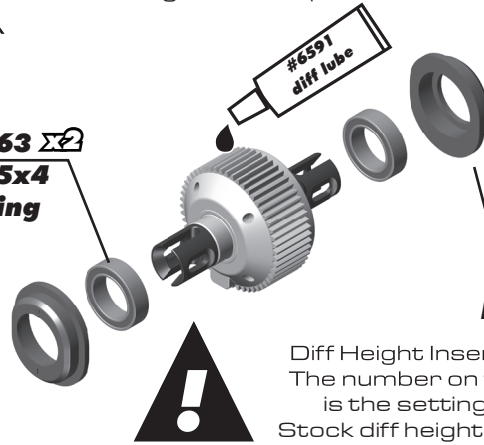

91792 $\Sigma 2$
B6.1 Diff Height Insert

Diff Height Inserts: The number on top is the setting. Stock diff height is 3.

91791
B6.1 Laydown Gearbox Top

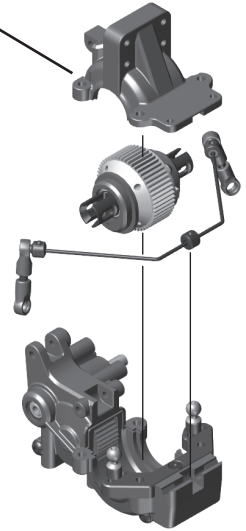

:: Bag 6 - Step 4

89202 $\Sigma 2$
3 x 12mm BHCS

89203 $\Sigma 2$
3 x 16mm BHCS

91709
Lay-Down Chassis Brace

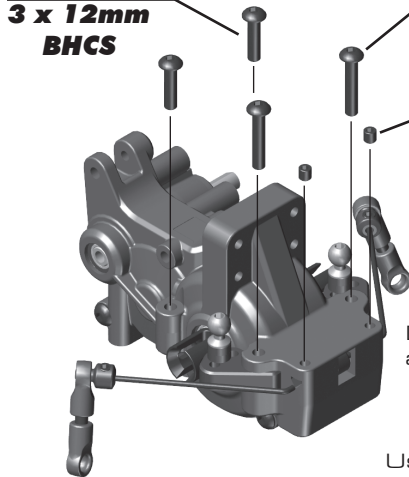

25225 $\Sigma 2$
M3 x 3mm Set Screw

Do not over-tighten the anti-roll bar set screws. The anti-roll bar should rotate freely in the assembly. Use set screws to remove up and down play from the anti-roll bar.

91819
B6.1 Shock Pivot Ball

89203
3 x 16mm BHCS

25188
3 x 20mm BHCS

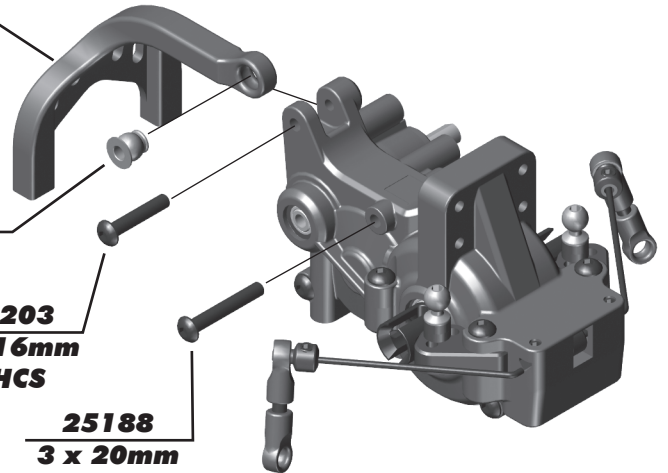

:: Bag 6 - Step 5

91813
B6.1 Gear Guard

71145
T6.2 Laydown Motor Plate

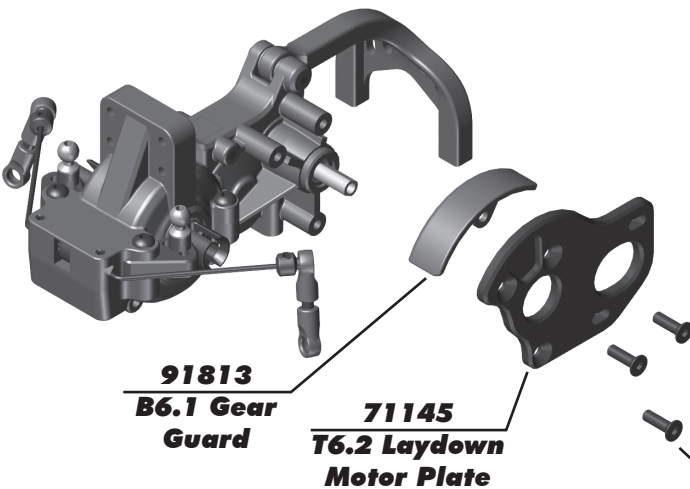

91803
B6.1 Slipper Hub, Inner

92295
Octalock Spur Gear, 78T 48P



There's also a 72T, 48P spur gear (#92293) included for stock motor use!

92285 $\Sigma 2$
FT Octalock LCF Slipper Pad, 11mm

#92295 spur gear walls should point away from gear box.

25202 $\Sigma 3$
3 x 10mm FHCS

91804
B6.1 Slipper Hub, Outer

91799
B6.1 Top Shaft Screw and Pin

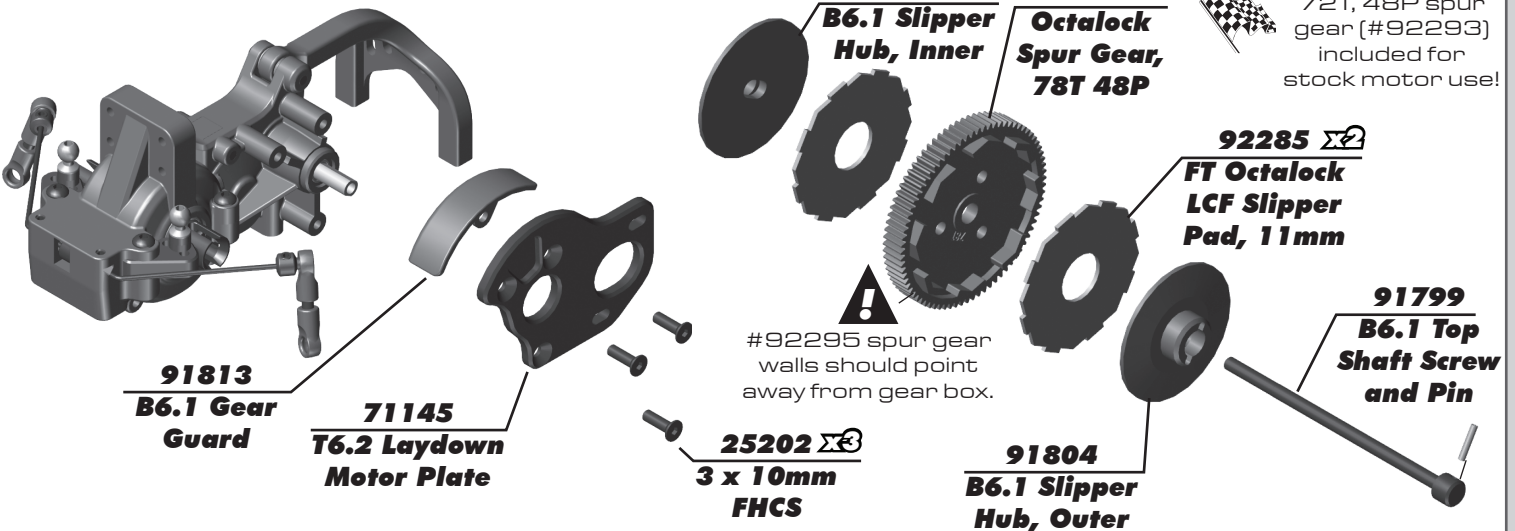

:: Bag 6 - Step 6

91891
Slipper Spring
Adapter, Outer

91891
Slipper Spring
Adapter, Inner

25612
M3 Locknut,
Flanged

92276
B74.1 Slipper
Spring, 500lb

41095 $\Sigma 2$
M3 x 22mm
LP SHCS

91885 $\Sigma 2$
Rear Tower
Cover

91881
Rear Shock
Tower, B6.3

92159 $\Sigma 2$
Shock
Bushing,
10mm

! See page 20 for gear mesh, and slipper clutch setting instructions!

! Set nut flush with top shaft.

:: Bag 6 - Step 7

91718 $\Sigma 2$
Rear Wing
Mount

91718 $\Sigma 2$
Rear Wing
Mount Spacer

25188 $\Sigma 4$
M3 x 20mm
BHCS

#25188 x4 (M3x20mm)
#89202 x4 (M3x12mm)

! *use 12mm length screws if rear wing mount spacer is removed.

89202 $\Sigma 4$
M3 x 12mm
BHCS

25204 $\Sigma 2$
M3 x 16mm
FHCS

25202 $\Sigma 6$
M3 x 10mm
FHCS

:: Bag 7 - Step 1

91047
Heavy-duty
Ballstud,
6mm

#1596
thread lock

31383
Ballstud Washers,
5.5x2.0mm, blue

92180
Rear Hub
Link Mounts

91857
B6.2 Rear
Hubs

92179
Rear Hub
Inserts

#1596
thread lock

89202
M3 x 12mm
BHCS

Build x2 (right and left side)

Rear Axle Height			
↑ 3	0 ↓		3 ↑ +3mm Kit Setup
↑ 2	1 ↓		2 ↑ +2mm
↓ 2	1 ↑		1 ↑ +1mm
↓ ε	0 ↑		0 ↑ +0mm

:: Bag 7 - Step 2

91438
CVA
Coupler

#6588
black grease

91860
CVA Bone,
69mm

91438
CVA Pin

91859
B6.2 CVA
Axle, +2mm

91563
10 x 15 x 4
Bearing

91567
5 x 12 x 4
Bearing

Note the location of the "L" and "R" on the rear hub!

Build x2

Build x2 (right and left side)

:: Bag 7 - Step 3

91436
CVA Wheel
Hex Pin

91609
Clamping Wheel
Hex, 5mm Offset
(rear)

91611
M1.6 x 5mm
SHCS

25215
M3 Locknut

92188
Rear Hub
Hinge Pin

92179
Rear Hub
Spacer

Do not overtighten the 1.6 x 5mm SHCS into the Clamping wheel hex.

Hinge Pin will be tight in the rear hub, but should rotate freely in the rear arms.

Build x2 (right and left side)

Build x2 (right and left side)

:: Bag 8 - Step 1

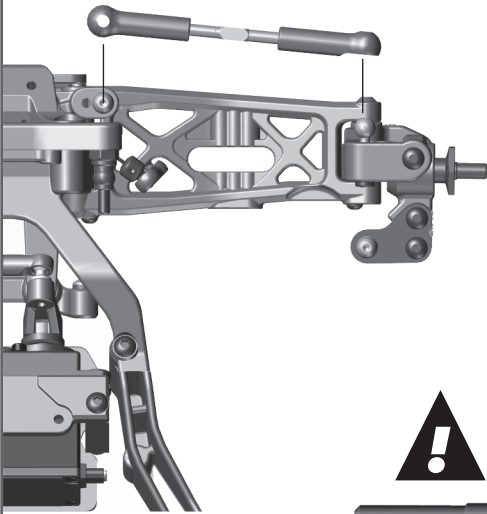

Racers Tip:

Use black grease (#6588) on the threads of the turnbuckles for easier ball cup installation!



Orient the notch to the left throughout the car. It indicates which end has the left hand threads!



91722
Ball Cup

91723
Turnbuckle
3x48mm

91722
Ball Cup

Front Camber Turnbuckle
22.60mm



Build x2 (right and left side)

:: Bag 8 - Step 2

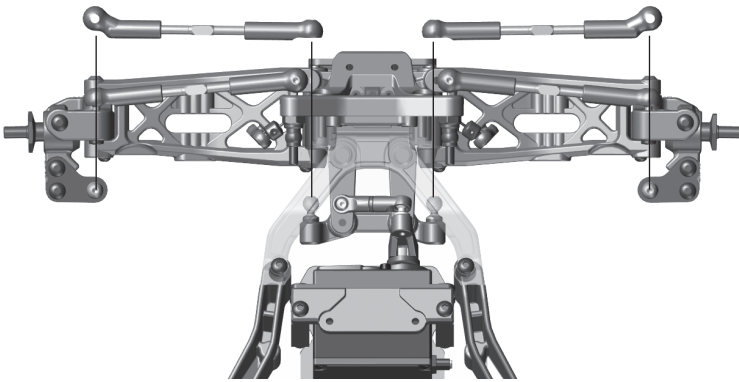

Letter L/R on plastic will be reversed when installed, follow the image!



Orient the notch to the left throughout the car. It indicates which end has the left hand threads!



91722
Ball Cup

91723
Turnbuckle
3x48mm

91722
Ball Cup

Steering Turnbuckle
27.90mm



Build x2 (right and left side)

:: Bag 8 - Step 3

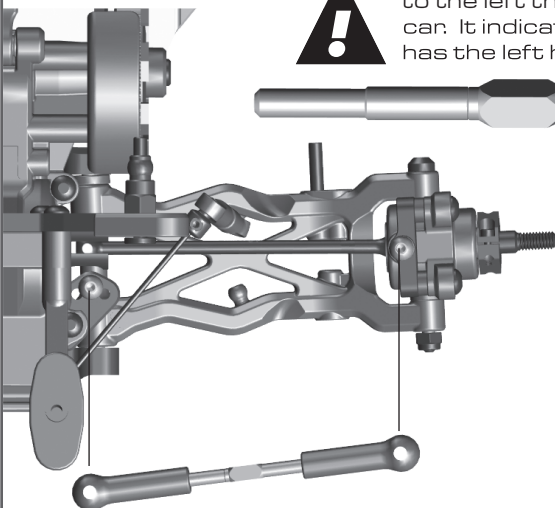

Orient the notch to the left throughout the car. It indicates which end has the left hand threads!



91722
Ball Cup

91723
Turnbuckle
3x48mm

91722
Ball Cup

Rear Camber Turnbuckle
25.30mm



Build x2 (right and left side)

:: Bag 9 - Step 1

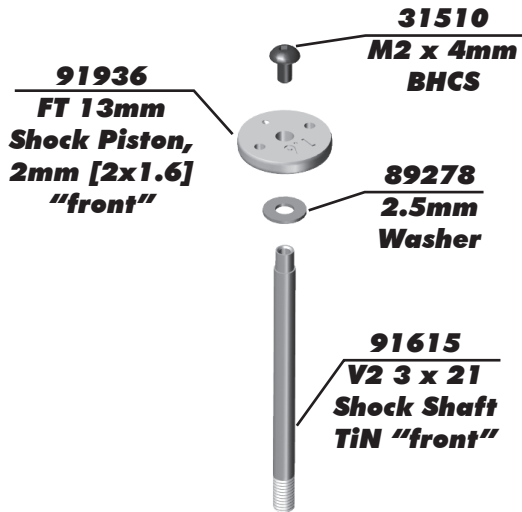

!
Mount the shock pistons with the number facing up!



Racers Tip:

Use a marker over the numbers on the pistons to make them easily visible!

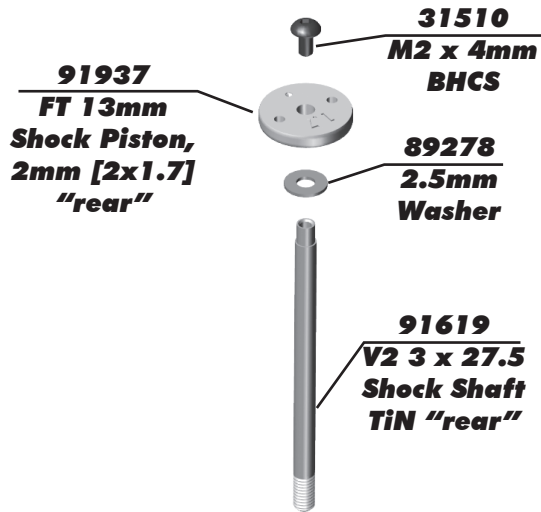

Build x2 front shocks

Build x2 rear shocks

:: Bag 9 - Step 2

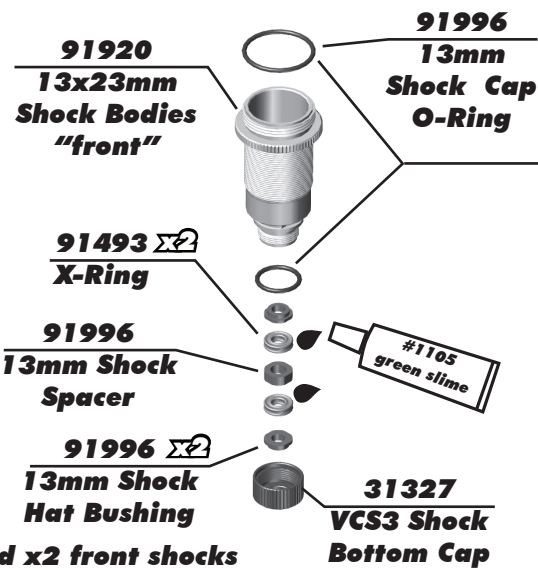

!
Lightly rub shock oil on the O-ring before installation!



Racers Tip:

Coating the O-rings with green slime (#1105) helps seal & reduce O-ring swell! **Green slime not included in kit!**

Build x2 front shocks

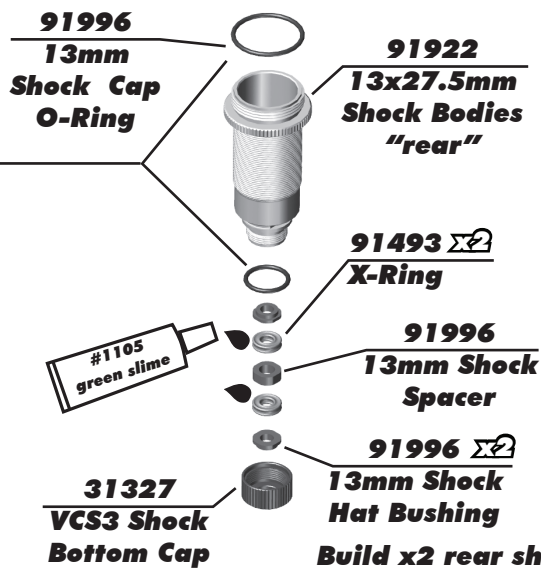

Build x2 rear shocks

:: Bag 9 - Step 3

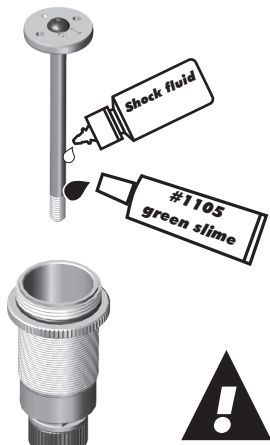

!
There are 3 lengths of shock eyelet in the kit. Pay attention to length when building as these affect your droop and uptravel.

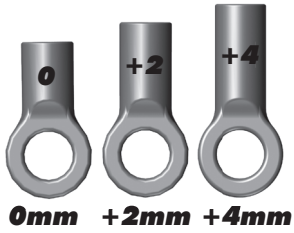

!
Lightly rub shock fluid or green slime on threads



Build x2 front shocks



Build x2 rear shocks

:: Bag 9 - Step 4

Front Shock: 35wt #5429
Rear Shock: 30wt #5422

Steps 2-3 **Steps 4-5** **Steps 6-7** **Step 8**

91926 13mm Shock Cap

Shock Bleeding Steps:

1. Before assembly, get each bleed screw and thread it 1-2 turns into the shock cap, then remove the screw. This will make it easier when you are bleeding your shocks.
2. Pull shock shaft down.
3. Fill shock body 3/4 full with silicone shock fluid.
4. Slowly move the shock shaft up and down to remove air from under the piston.
5. Wait for bubbles to come to surface.
6. Fill shock body to top with silicone shock fluid.
7. Place a drop of oil in the cap and on cap threads.
8. Install cap (without bleed screw) and tighten completely.
9. Slowly compress shaft all the way to bleed excess silicone shock fluid out the hole in the cap (use rag around shock to catch excess fluid).
10. Install M2x4mm button head screw until snug while shaft is fully compressed.

31510 M2 x 4mm BHCS

Stroke

Stroke Front: 21mm
Rear: 27.5mm

Steps 9-10

:: Bag 9 - Step 5

91996 x4 13mm Threaded Collar O-ring

91928 x4 13mm Threaded Collar

Build x4

91944 13mm Front Spring, Red (4.00lb)

91950 13mm Rear Spring, Blue (2.20lb)

Racers Tip:
Use your finger to rub shock fluid on the O-ring for smoother adjustment!

:: Bag 9 - Step 6

Front: 4.50mm

91926 13mm Shock Spring Cup (Front - 5mm)

Build x2 front shocks

Rear: 4.00mm

91926 13mm Shock Spring Cup (Rear - 0mm)

Build x2 rear shocks

#91926 13mm Shock Spring Cups

0mm 5mm 9mm

:: Bag 9 - Step 7



Use outside hole in front arm!

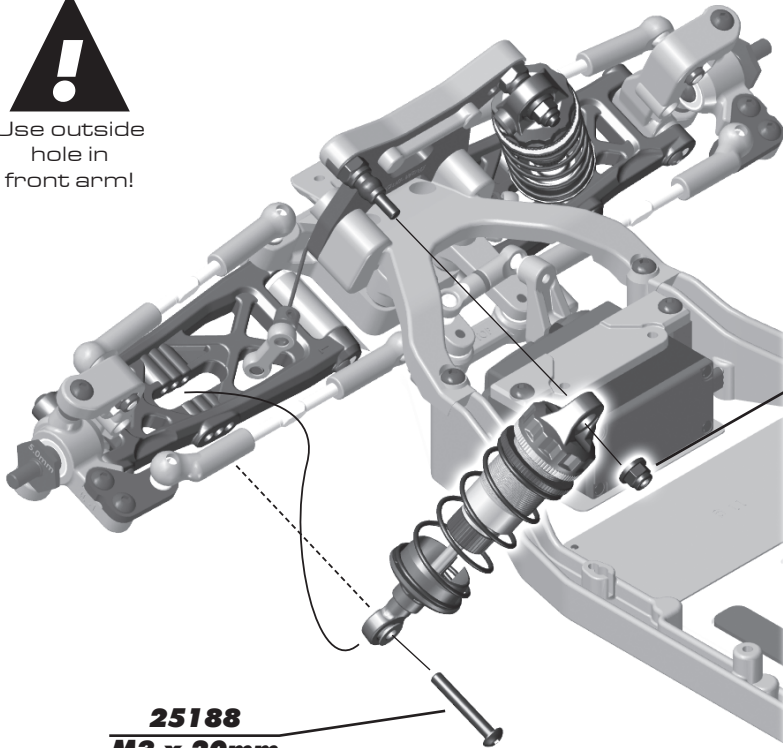

25188
M3 x 20mm
BHCS

25612
M3 Locknut
w/Flange

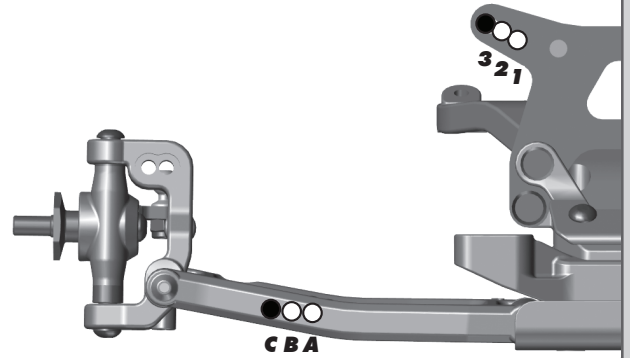

Build x2 (right and left side)

:: Bag 9 - Step 8



Make sure the flange on the shock pivot ball is towards the rear arm.

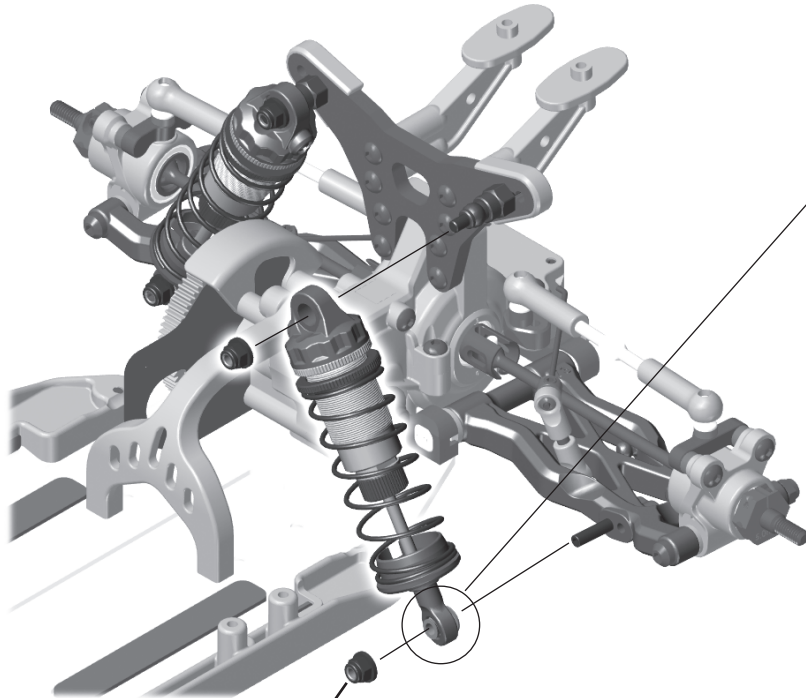

25612 x2
M3 Locknut
w/Flange

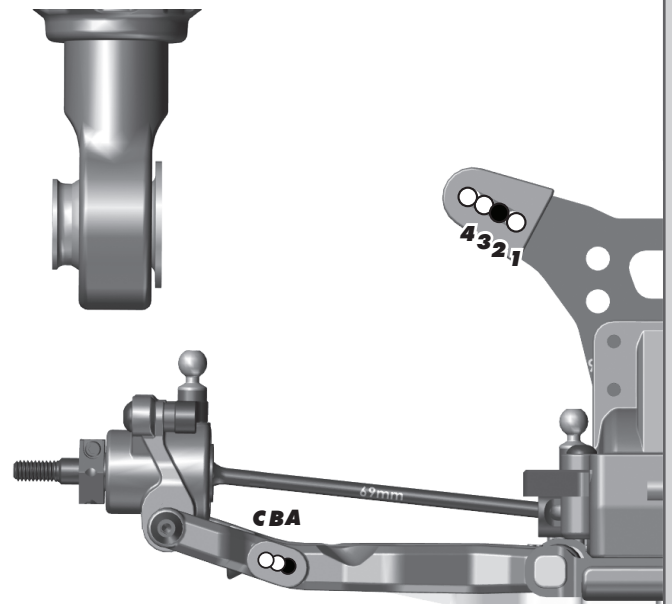

Build x2 (right and left side)

:: Bag 10 - Step 1



See page 25 for gear mesh setting instructions!

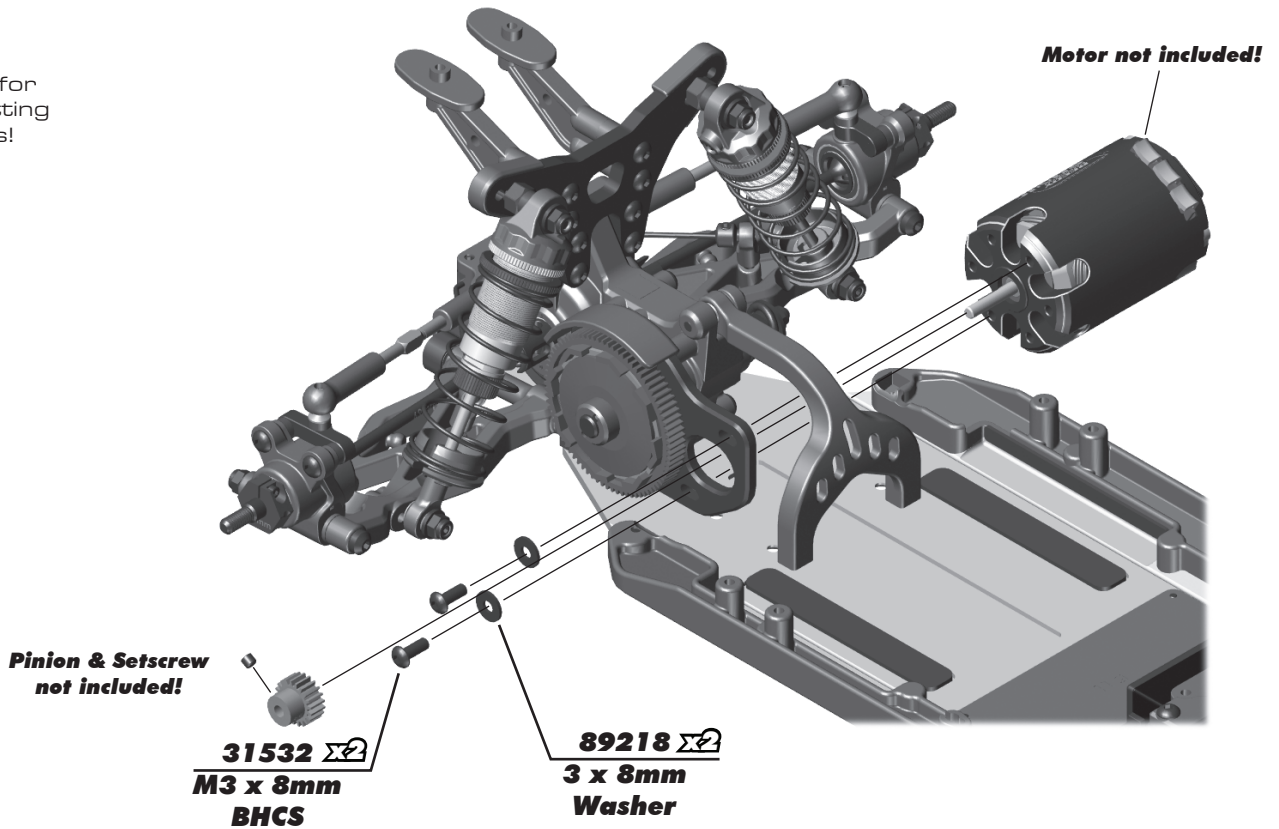

:: Bag 10 - Step 2



Fan mount options:
 #1 - Laydown gearbox
 #2 - Layback gearbox
 #3 - Endbell location
 #4 - Plug (no fan)

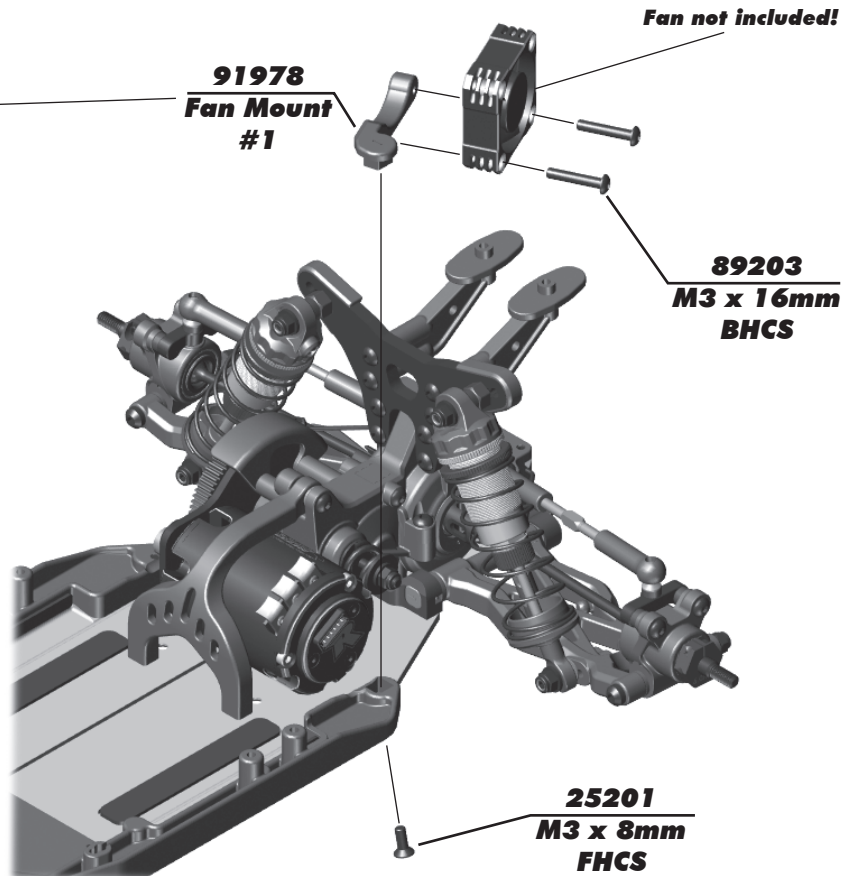

:: Bag 10 - Step 2

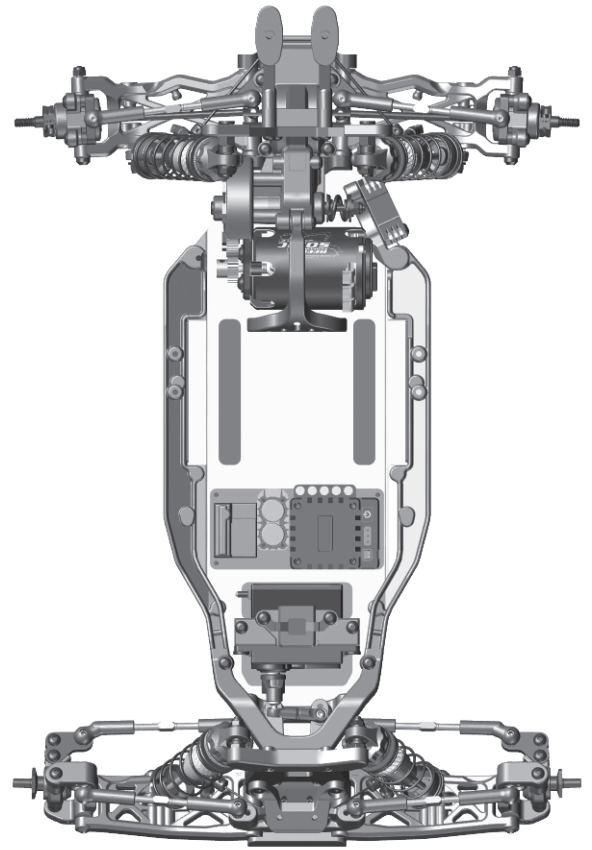
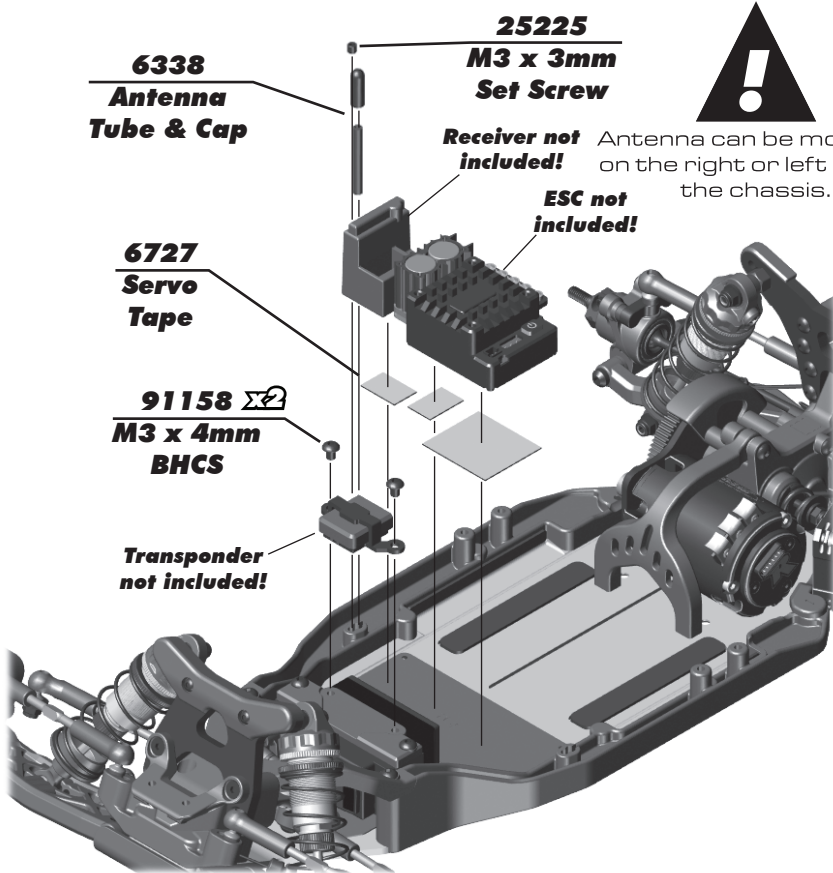

:: Bag 10 - Step 3

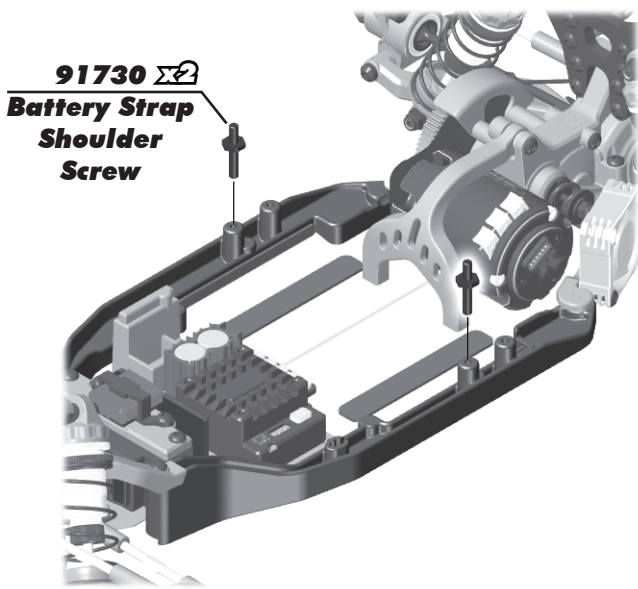

!
Make sure the battery strap shoulder screw is flush with the top of your battery pack!

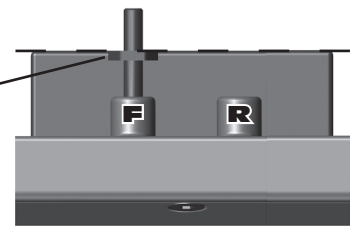

91731
Battery
Strap, B6

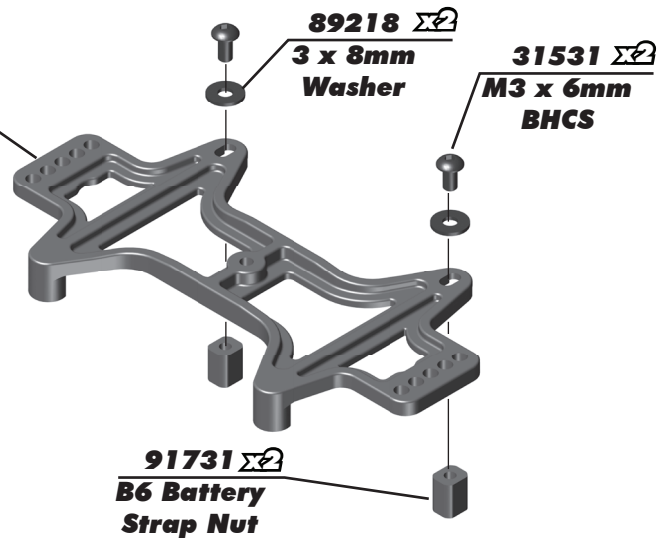

:: Bag 10 - Step 4

Front

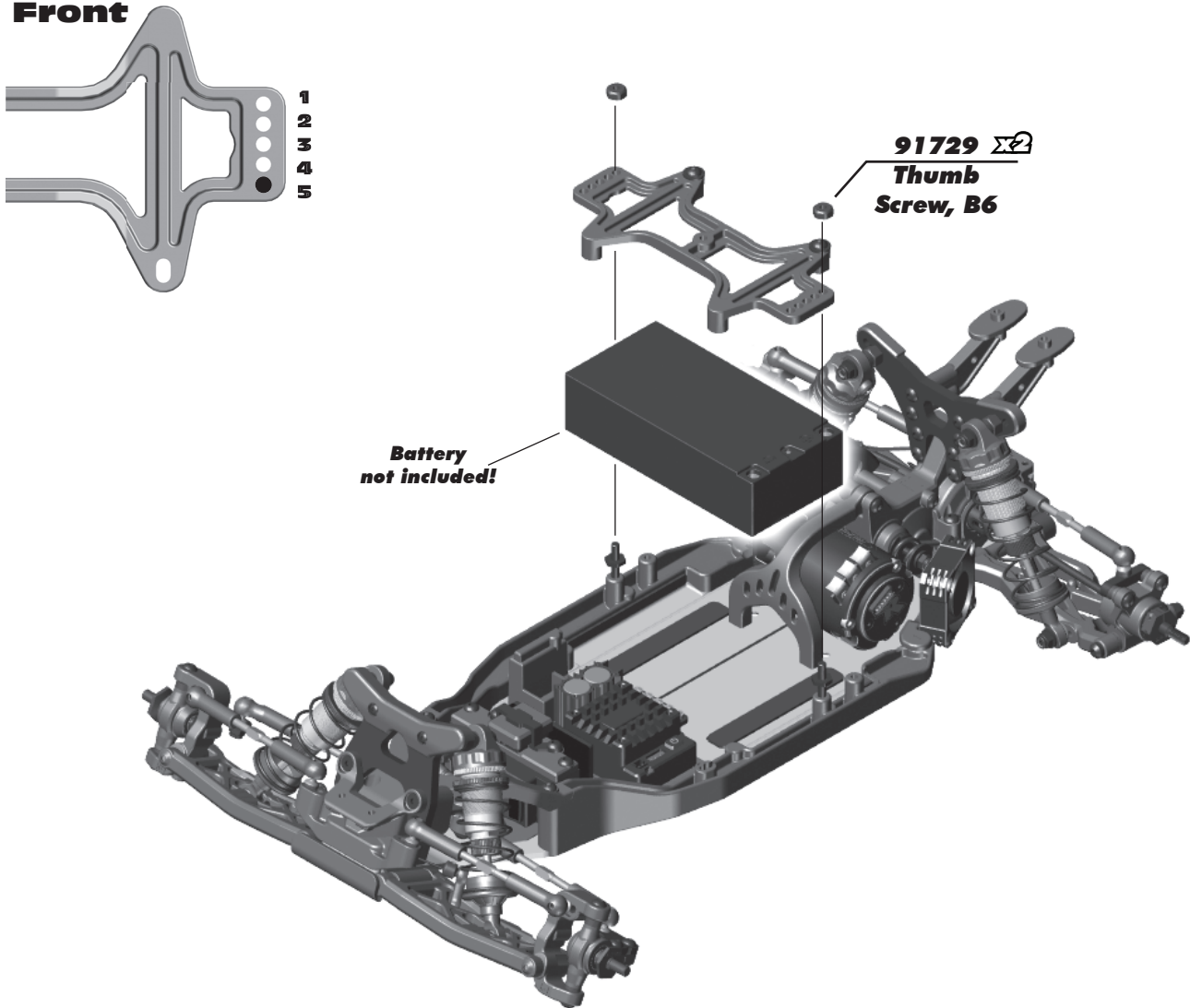

:: Bag 10 - Step 5 - Optional Chassis Brace Configuration

**91885
Rod End**

**91723
Turnbuckle
3x48mm**

**91885
Rod End**

**25612
M3 LockNut
w/Flange**

**91819 X2
Shock
Pivot Ball**

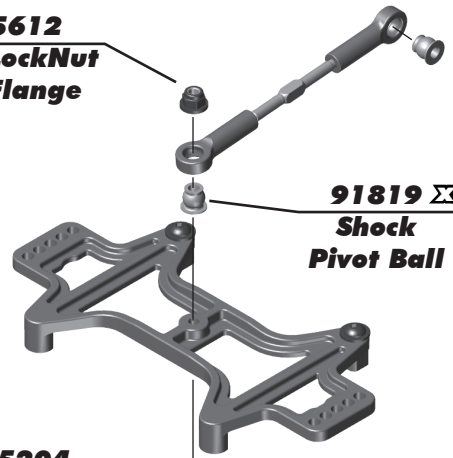

!!OPTION!!
Tune for more chassis flex

Installation: Remove the plastic chassis brace (3 screws) and install the battery brace turnbuckle with M3x16mm BHCS

**Battery Brace Turnbuckle
Varies with battery position
3F - 29mm**

Pro Tip: Set the turnbuckle length based on battery position, adjust the length as needed to mate with the gearbox.

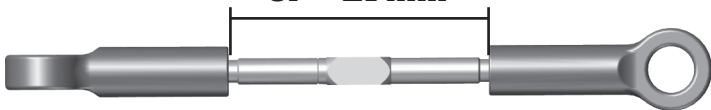

**25204
3 x 16mm
FHCS**

:: Bag 10 - Step 6

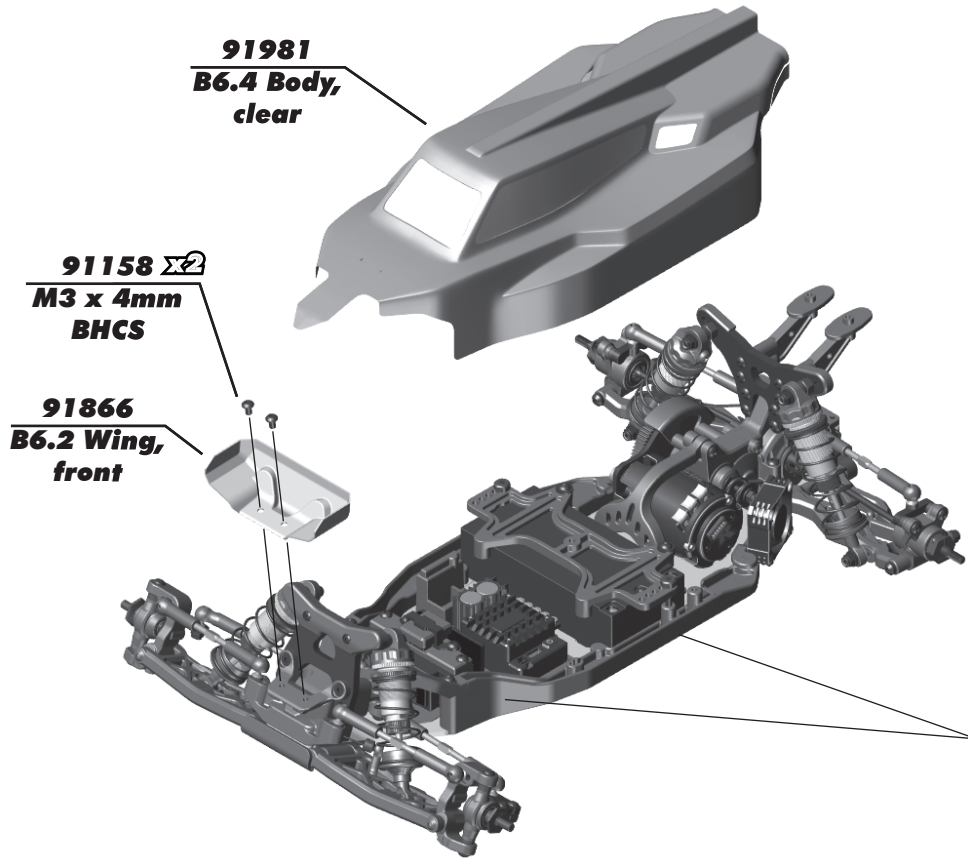

91981
B6.4 Body,
clear

91158
M3 x 4mm
BHCS

91866
B6.2 Wing,
front



Install hook and loop tape (#91743) along the side braces in 2 spots. One near the front, and one in the middle. Install the opposite side of the hook and loop tape inside the body!

:: Bag 10 - Step 7



Trim the front edge of the wing straight. Trim lines for shock clearance used ONLY for shocks mounted on the rear of the arms.

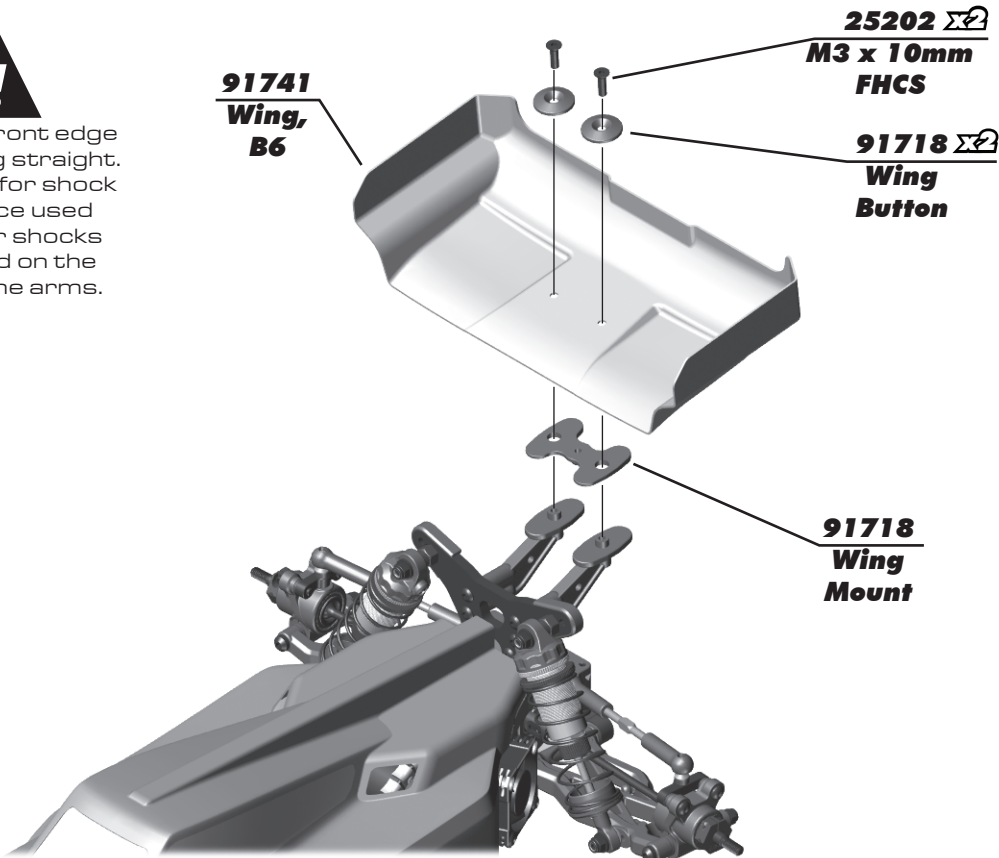

91741
Wing,
B6

25202
M3 x 10mm
FHCS

91718
Wing
Button

91718
Wing
Mount

Wing Mount



6° - Mount under wing - KIT



3° - Mount on top of wing



0° - Mount under wing

Front of Vehicle



:: Bag 10 - Step 8

Body Trimming / Mounting:

There are 2 body trimming options depending on what transmission you choose to run.

- Cut Line A is for #3 endbell or #4 no fan
- Cut Line B is for running a fan # 1 or #2 location.

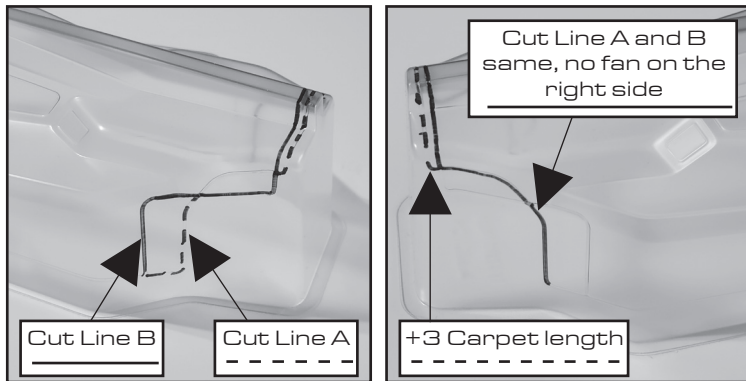

Body Trimming for Length:

There are 2 body trimming options depending on what transmission you choose to run.

- Cut the body on the top/rear, long for the B6.4, shorter for the B6.4D

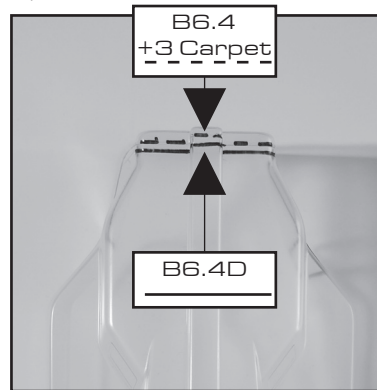

:: Bag 10 - Step 9



:: Bag 10 - Step 10



:: Tuning Tips

Painting:

Your Kit comes with a clear polycarbonate body. You will need to prep the body before you can paint it. Wash the INSIDE thoroughly with warm water and liquid detergent (do not use any detergents with scents or added hand lotion ingredients!). Dry the body using a clean, soft, lint-free cloth. Use the supplied window masks to cover the windows from the INSIDE of the body (RC cars get painted on the inside). Using high quality masking tape, apply tape to the inside of the body to create a design. Spray (use either rattle can or airbrush) the paint on the inside of the body (preferably dark colors first, lighter colors last). NOTE: ONLY use paint that is recommended for polycarbonate plastics. If you do not, you can destroy the body! After the paint has completely dried (usually after 24 hours), cut the body along the trim lines. Make sure to drill or use a body reamer to make the holes for the antenna if needed! Use hook and loop tape to secure the body to the side rails of the vehicle.

Tips for Beginners:

Before making any changes to the standard setup, make sure you can get around the track without crashing. Changes to your vehicle will not be beneficial if you can't stay on the track. Your goal is consistent laps. Once you can get around the track consistently, start tuning your vehicle. Make only ONE adjustment at a time, testing it before making another change. If the result of your adjustment is a faster lap, mark the change on the included setup sheet (make additional copies of the sheet before writing on it). If your adjustment results in a slower lap, revert back to the previous setup and try another change. When you are satisfied with your vehicle, fill in the setup sheet thoroughly and file it away. Use this as a guide for future track days or conditions. Periodically check all moving suspension parts. Suspension components must be kept clean and move freely without binding to prevent poor and/or inconsistent handling.

Rear Arm Mount Pill Insert Setup:

The aluminum rear arm mounts utilize eccentric pill inserts to make fine adjustments to anti-squat, toe, pin heights, and pin width. Adjustments can be made using the supplied inserts (#92014)

Standard Position
Use this position as a reference when changing pill locations.

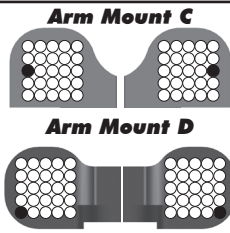

Toe: 3°
Anti-squat: 2°
Roll Center: +0
Pivot Width: +0

Insert Hole Locations

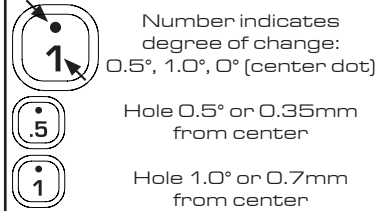

Anti-squat Angle

More angle = More anti-squat
Less angle = Less anti-squat
Shown in 1° changes

C Mount	D Mount	
		+ 1°
		= 0°
		= -1°
		= 2°
		= 1°
		= 0°
		= -3°
		= -2°
		= 1°

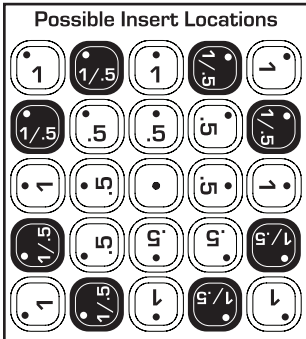

Pin Width

More distance = wider pivot
Less distance = narrow pivot
*Note: For pin width -1.4mm, use 67mm CVA driveshafts

C Mount	D Mount	
		= +1.4mm
		= +0.7mm
		= 0mm
		= -0.7mm
		= -1.4mm*

Pin Height

Higher pin = Higher roll center
Lower pin = lower roll center

C Mount	D Mount	
		= +0.7mm
		= +0.35mm
		= 0mm
		= -0.35mm
		= -0.7mm

Toe Angle

More angle = More toe in
Less angle = Less toe in
Shown in 1° changes

C Mount	D Mount	
		= 3°
		= 4°
		= 5°
		= 2°
		= 3°
		= 4°
		= 1°
		= 2°
		= 3°



For additional setup tips, please visit our website by using the link or QR code below.

<http://bit.ly/B6PillChart>



:: Tuning Tips (cont.)

Motor Gearing:

Proper motor gearing will result in maximum performance and run time while reducing the chance of overheating and premature motor failure. The gear ratio chart lists recommended **starting gear ratios** for the most widely used motor types. Gear ratios will vary depending upon motor brand, wind, and electronic speed control. Consult your motor and electronic speed control manufacturers for more information.

Team Associated is not responsible for motor damage due to improper gearing.

B6 Gear Ratio Chart (Internal Gear Ratio 2.60:1)

Motor	Pinion	Spur	Final Drive Ratio
21.5 Reedy S-Plus Brushless	33	72	5.67:1
17.5 Reedy S-Plus Brushless	29	72	6.45:1
13.5 Reedy S-Plus Brushless	27	*75	7.22:1
10.5 Reedy 540-M4 Brushless	24	78	8.45:1
9.5 Reedy 540-M4 Brushless	23	78	8.82:1
8.5 Reedy 540-M4 Brushless	22	78	9.22:1
7.5 Reedy 540-M4 Brushless	21	78	9.65:1
6.5 Reedy 540-M4 Brushless	20	78	10.14:1

*75T spur gear (#92294) not included

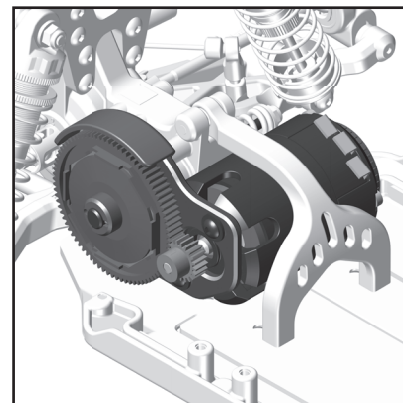

Set The Gear Mesh:

You should be able to rock the spur gear back and forth in the teeth of the pinion gear without making the pinion gear move. If the spur gear mesh is tight, then loosen the #31532 screws (p.19) and move the motor away, then try again. A gear mesh that is too tight or too loose will reduce power and damage the gear teeth.

Diff Height Adjustment:

The diff height adjustment (p.12) is a good way to tune the car for grip level. On high grip with low ride heights, a higher diff height will be a good option. On lower grip with higher ride heights, a lower diff height will be better.

Gear Box Type:

Selecting the correct gear box is dependent on the type of track it will be used on. The optional 4-gear standup gear box is for the lowest grip conditions. This gear box moves the weight towards the rear of the car and also uses the rotation of the motor to transfer weight to the rear while on-power. The 3-gear standup gear box also moves the weight towards the rear of the car, but in this configuration, the motor's rotation helps with on-power steering. The laydown gear box is used on high grip conditions when on-power steering and stability are most important. This gear box will change directions the quickest and generate the most steering. Layback is used for most indoor clay track conditions.

Slipper Clutch:

The assembly instructions give you a base setting for your clutch. Turn the nut on the shaft so that the end of the top shaft is even with the outside of the nut. At the track, tighten or loosen the nut in 1/8 turn increments until you hear a faint slipping sound for 1-2 feet on takeoffs. Another popular way to set the clutch is to hold both rear tires firmly in place and apply short bursts of throttle. If the clutch is properly set, the front tires should lift slightly up off the surface.

Caster:

Caster describes the angle of the caster block as it leans toward the rear of the vehicle. Positive caster means the kingpin leans rearward at the top. The kit includes three inserts to adjust caster angle at the caster block, 0°, 2.5°, and +5°. The total caster angle is the sum of the kick-up angle and the caster block angle. Standard total caster angle for the B6 is 30°, with 25° kick-up and +5° caster block angle.

For less entry steering and more exit steering, try 0° caster block angle.

Front Camber:

Camber describes the angle at which the tire and wheel rides when looked at from the front. Negative camber means that the tire leans inward at the top. A good starting camber setting is -1°. Positive camber, where the top of the tire is leaning out, is not recommended. A camber gauge can be used to more accurately set camber.

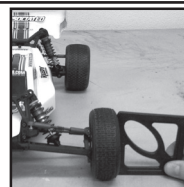

Testing camber with camber gauge

Rear Camber:

Camber describes the angle at which the tire and wheel rides when looked at from the back. Negative camber means that the tire leans inward at the top. A good starting camber setting is -1°. Adding a small amount of positive camber, where the top of the tire is leaning out, will tend to improve straight-line acceleration on loose tracks. A camber gauge can be used to more accurately set camber.

FIND IT ON ASSOCIATEDELECTRICS.COM

CARS & TRUCKS



Vehicle Spare Parts

GO TO:

[AssociatedElectrics.com](#) →
[Team Associated tab](#) →
[Cars & Trucks](#) →
[Scroll to your vehicle](#) →
[Parts & Accessories link](#)

SETUP SHEETS & MANUALS



Setups and Manuals

GO TO:

[AssociatedElectrics.com](#) →
[Team Associated tab](#) →
[Manuals & Setups](#) →
[Scroll to your vehicle](#)

A-TEAM APPS



Tuning Guides & Tips

GO TO:

[AssociatedElectrics.com](#) →
[Support](#) →
[A-Team Apps](#)



Associated Electrics, Inc.

21062 Bake Parkway Lake Forest, CA 92630 USA

call: (949) 544-7500 - fax: (949) 544-7501

**Check out the following web sites for all of our kits, current products,
new releases, setup help, tips, and racing info!**

www.AssociatedElectrics.com

FOLLOW US ON SOCIAL MEDIA



TeamAssociated
ReedyPower
ElementRC



@TeamAssociatedRC
@ReedyPower
@Element_RC



@Team_Associated
@ReedyPower