

# RC 1:10 TEAM BE4D KIT

1:10 Scale 2WD Electric Off Road  
Competition Buggy Kit



SCALE 1:10 VEHICLE

KIT

2 WHEEL DRIVE

ELEC. POWERED

OFF ROAD

NOT INCLUDED

CLEAR BODY

#90035 RC10B6.4D TEAM KIT

1:10 Scale 2WD Electric Off Road Competition Buggy Manual



CHAMPIONS by DESIGN

AssociatedElectrics.com

# TEAM ASSOCIATED

## :: Introduction

Thank you for purchasing this Team Associated product. This assembly manual contains instructions and tips for building and maintaining your new vehicle. Please take a moment to read through the manual and familiarize yourself with the steps. We are continually changing and improving our designs; therefore, actual parts may appear slightly different than the illustrations. New parts will be noted on supplementary sheets located in the appropriate parts bags. Check each bag for these sheets before you start to build.

## :: RC10B6.4D KIT Features

- New 13mm big-bore threaded aluminum shocks and springs with machined shock pistons for improved handling
- New dirt length aluminum chassis with 22.5° kick-up to complement updated front-end geometry and with new shape to reduce chassis scrub with the track surface
- 20°, 22.5°, and 25° molded bulkheads included for a complete range of caster and kickup options
- New adjustable height steering bellcrank and rack system for optimized bumpsteer at all ride heights and caster angles
- New -1mm kingpin offset steering and caster block set for smoother and more predictable steering through the entire wheel throw
- New aluminum RC10B6.4D ESC weight shifted forward in the chassis and with a wider footprint to fit electronics results in a further forward weight bias
- New front ballstud mount, top plate, and front wing mount to account for the kickup angle change
- New chassis side rails with 3 optional fan mount locations to choose from
- New caged thrust bearing for ball differential
- New cab-forward design RC10B6.4 bodyshell offered in standard (kit) and lightweight (optional) thickness
- Front wing mount and front wing included
- Clear body and clear wing included
- 5mm aluminum clamping rear wheel hexes

## :: Additional

Your new B6.4D Team Kit comes unassembled and requires the following items for completion (Refer to [www.rc10.com](http://www.rc10.com) and [www.Reedypower.com](http://www.Reedypower.com) for complete listings):

- RC two channel surface frequency radio system
- AA-size batteries for transmitter (#302 alkaline)
- Electronic Speed Control, ESC
- Steering servo
- 540 size electric motor
- Pinion gear (48P), size determined by type/wind of motor
- Battery charger (a peak detection charger, or LiPo compatible charger)
- 2 cell LiPo battery pack
- Polycarbonate specific spray paint
- Cyanoacrylate glue (CA)(#1597)
- Thread locking compound (#1596)
- Tires and Inserts, Fronts and Rears
- Wheels w/12mm Hex  
Front Wheels #9690, #9691  
Rear Wheels #9695, #9696
- Slim Front Wheels w/12mm Hex (carpet/astro use)  
#91757 (white) #91758 (yellow)

## :: Other Helpful Items

- Silicone Shock Fluid (Refer to [www.rc10.com](http://www.rc10.com) for complete listings):
- Body Scissors (AE Part #1737)
- FT Hex/Nut Wrenches (AE Part #1519, 1650)
- Green Slime shock lube (AE Part #1105)
- Soldering Iron
- Needle Nose Pliers
- FT Body Reamer
- FT Ballcup Wrench (#1579)
- FT Dual Turnbuckle Wrench (#1114)
- Hobby Knife
- Shock Pliers
- FT Universal Tire Balancer (#1498)
- Calipers or a Precision Ruler
- Wire Cutters

















**Associated Electrics, Inc.**  
21062 Bake Parkway  
Lake Forest, CA 92630











**Customer Service**  
Tel: 949.544.7500  
Fax: 949.544.7501

**:: Hardware - 1:1 Scale View**





**Button Head (bhcs)**

	<b>2x4mm (31510)</b> <b>Aluminum (8545)</b>
	<b>2.5x6mm (31520)</b>
	<b>2.5x8mm (31521)</b>
	<b>2.5x10mm (31522)</b>
	<b>3x4mm (91158)</b>
	<b>3x5mm (31530)</b>
	<b>3x6mm (31531)</b>
	<b>3x8mm (31532)</b>
	<b>3x10mm (25211)</b>
	<b>3x12mm (89202)</b>
	<b>3x14mm (25187)</b>
	<b>3x16mm (89203)</b>
	<b>3x18mm (2308)</b>
	<b>3x20mm (25188)</b>
	<b>3x22mm (25189)</b>
	<b>3x24mm (89204)</b>
	<b>3x30mm (91478)</b>





**Flat Head (fhcs)**

	<b>2x3mm (91749)</b>
	<b>2.5x8mm (31448)</b>
	<b>3x8mm (25201)</b>
	<b>3x10mm (25202)</b>
	<b>3x12mm (25203)</b>
	<b>3x14mm (89208)</b>
	<b>3x16mm (25204)</b>
	<b>3x18mm (89209)</b>



**Set Screws**

	<b>3x2.5mm (31500)</b>
	<b>3x3mm (25225)</b>
	<b>3x5mm (89219)</b>
	<b>3x10mm (4671)</b>
	<b>3x20mm (91737)</b>





**Socket Head (shcs)**

	<b>1.6 x 5mm (91611)</b>
	<b>3 x 18mm (25191)</b>
	<b>3 x 6mm (41089)</b>
	<b>3 x 22mm (41095)</b>









**Shims and Washers**

	<b>5.5x0.5mm (31381)</b>
	<b>5.5x1.0mm (31382)</b>
	<b>5.5x2.0mm (31383)</b>
	<b>2.6x6mm Washer (89278)</b>
	<b>3x8mm Washer (89218)</b>









**Ball Bearings**

	<b>4x7x2.5mm (31732)</b>
	<b>5x8x2.5mm (8680)</b>
	<b>5x10x4mm (91560)</b>
	<b>5x12x4mm (91567)</b>
	<b>10x15x4mm (91563)</b>





**Ballstuds**

	<b>Silver 5mm long (31283)</b>
	<b>Silver 8mm long (31284)</b>
	<b>HD 6mm (91047)</b>
	<b>Ti HD 6mm (91751)</b>
	<b>HD 8mm (91048)</b>
	<b>Ti HD 8mm (91752)</b>
	<b>HD 10mm (91049)</b>
	<b>Ti HD 10mm (91753)</b>

**Nuts (lock/plain)**

	<b>M3 Plain Nut (91477)</b>
	<b>M3 Alum. Locknut, Blue (31550)</b>
	<b>M3 Locknut, Black (25215)</b>
	<b>M3 Locknut w/Flange (25612)</b>
	<b>FT 3mm Locknuts, Blue(25392)</b>
	<b>M4 Nuts: Serrated Steel (Silver)(91826)</b>
	<b>FT Alum. Locknut (Blue) (25391)</b>
	<b>Serrated Steel (Black) (91738)</b>
	<b>Serrated Steel LP (Black) (91150)</b>

**Diff Balls**

	<b>3/32 Carbide Diff Balls (6581)</b>
	<b>3/32 Ceramic Diff Balls (6584)</b>
	<b>Thrust Washer (91990)</b>
	<b>Caged Thrust Washer (91990)</b>

**Notes:**

**:: Table of Contents**

1..... Cover	14.....Bag 7: Rear Hubs
2..... Introduction	15.....Bag 8: Turnbuckles
3.....1:1 Hardware "Fold Out"	16 - 18.....Bag 9: Shocks
4..... Table of Contents	19 - 23.....Bag 10: Battery Strap, Body, and Wheels
5.....Bag 1: Steering	24 - 25..... Tuning Tips
6 - 8.....Bag 2: Front Suspension	26..... Back Cover
8 - 9.....Bag 3: Caster Blocks	
9 - 10.....Bag 4: Rear Suspension	
10 - 11.....Bag 5: Ball Diff	
11 - 13.....Bag 6: Gearbox	

**:: Notes**

***This symbol indicates a special note or instruction in the manual.***



***This symbol indicates a Racers Tip.***



***There is a 1:1 hardware foldout page in the front of the manual. To check the size of a part, line up your hardware with the correct drawing until you find the exact size. Each part in the foldout has a number assigned to it for ordering replacement parts.***

**Associated Electrics, Inc.  
21062 Bake Parkway  
Lake Forest, CA 92630**



**Customer Service  
Tel: 949.544.7500  
Fax: 949.544.7501**

**:: Bag 1 - Step 1**

**!**  
Note orientation of steering rack.

**Front**  
TOP

**31732 x4**  
4 x 7 x 2.5 Ball Bearing

**91973**  
Steering Bellcrank (Right)

**31283**  
5mm Ball Stud, Long

**91973**  
Steering Bellcrank (Left)

**91973**  
Steering Rack

**91048** **Heavy-duty Ballstud, 8mm**

**31382** **FT Ballstud Washer, Aluminum (1mm)**

**89202** **M3 x 12mm BHCS**

**91974** **Steering Hat Bushing**

**:: Bag 1 - Step 2**

**25191** **M3 x 18mm SHCS**

**91974** **Steering Hat Bushing, Low**

**31732 x4**  
4 x 7 x 2.5 Ball Bearing

B6.4 Kickup/Steering Option Chart				
Steering	Bulkhead	Caster Insert	Chassis	Total Insert
High	2.5°	0°	22.5°	25°
Low	2.5°	2.5°	22.5°	27.5°
Low	2.5°	5°	22.5°	30°
High	0°	0°	22.5°	22.5°
High	0°	2.5°	22.5°	25°
Low	0°	5°	22.5°	27.5°
High	-2.5°	0°	22.5°	20°
High	-2.5°	2.5°	22.5°	22.5°
High	-2.5°	5°	22.5°	25°

**91049** **Heavy-duty Ballstud, 10mm**

**31382** **FT Ballstud Washer, Aluminum (1mm)**

**91971**  
**Front Ball Stud Mount**

**!**  
[Low position] Bellcranks down, hat side on top  
[High position] Bellcranks up, hat side on bottom

**:: Optional Anti-Roll Bar Build - NOT INCLUDED**

!Tuning option!

**NOT INCLUDED**

**31500**  
M3 x 2.5mm Set Screw

**91822**  
Anti-Roll Bar, Blue (1.0mm)

**91821**  
Anti-Roll Bar Collar

**!**  
Do not overtighten #31500 - M3 x 2.5mm set screw. You could bend the bar!

**:: Bag 2 - Step 1**

**91967**  
**B6.4**  
**Chassis**

**91979**  
**Bulkhead**  
**(use 0°)**

**89208** **M3 x 14mm**  
**FHCS**

**Note:**  
Check the screw length as both 14mm and 16mm are in the screw bag. Use the shorter of the two screws!

There are two bulkheads included in the kit (0°, 2.5°). 0° is the standard used. The arrows on the 2.5° bulkhead should point forward for the desired setting.

**:: Bag 2 - Step 2**

**91976**  
**B6.4 FT Alum.**  
**Chassis Weight,**  
**13g**

**91988**  
**Battery**  
**Foam, B6.4**

**91969**  
**Side Rails**  
**(L & R)**

**91988**  
**Battery**  
**Foam, B6.4**

**91749** **M2 x 3mm**  
**FHCS**

**#1596**  
**thread lock**

**25202** **M3 x 10mm**  
**FHCS**

**25201** **M3 x 8mm**  
**FHCS**

**:: Bag 2 - Step 3**

**91997** **Steering**  
**Link, B6.4**

**31382**  
**FT Ballstud**  
**Washer, Aluminum**  
**(1mm)**

**4671**  
**M3x10mm**  
**Set Screw**

**31284**  
**8mm Ball**  
**Stud, Long**

**31531**  
**M3 x 6mm**  
**BHCS**

**91728**  
**Servo**  
**Horn**

**91728**  
**Servo Horn**  
**Ring**

Align the servo horn 90 degrees

Servo not included!

Tighten the steering link ball cups all the way until snug.

23T: Sanwa/ KO/ JR / Spektrum  
24T: Hitec  
25T: Reedy/ Futaba/ Savox/ ProTek / MKS

**:: Bag 2 - Step 4**

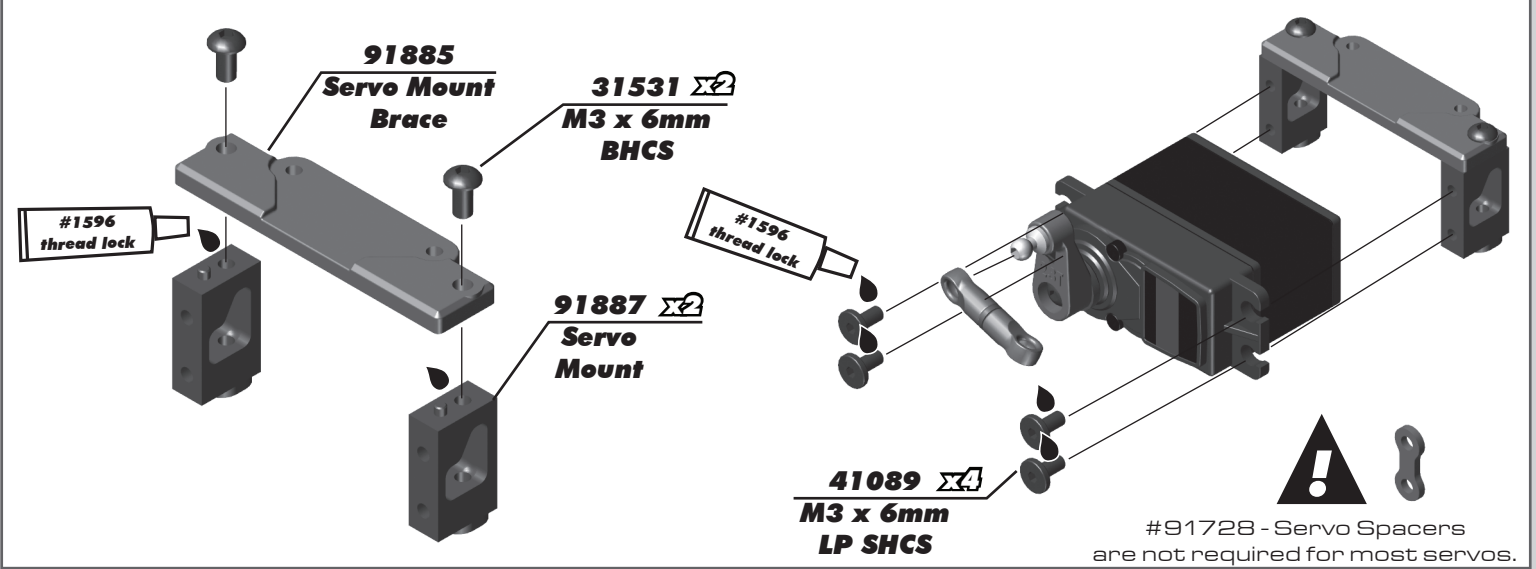

**:: Bag 2 - Step 5**

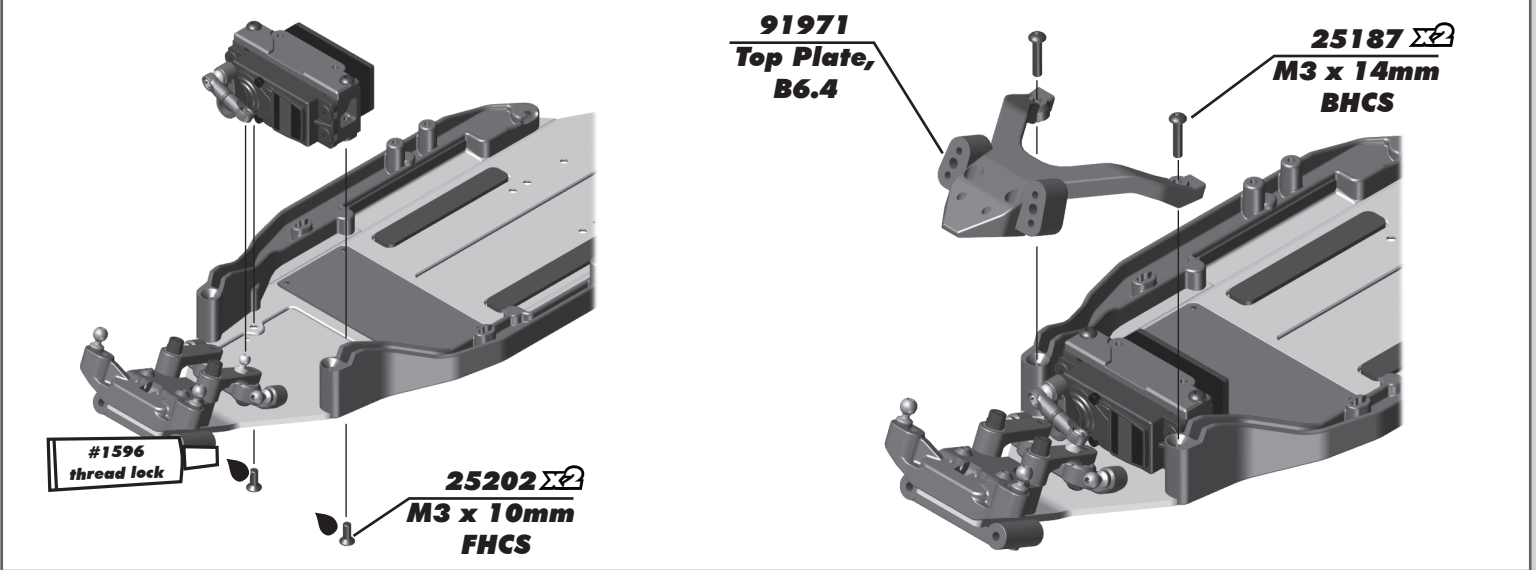

**:: Bag 2 - Step 6**

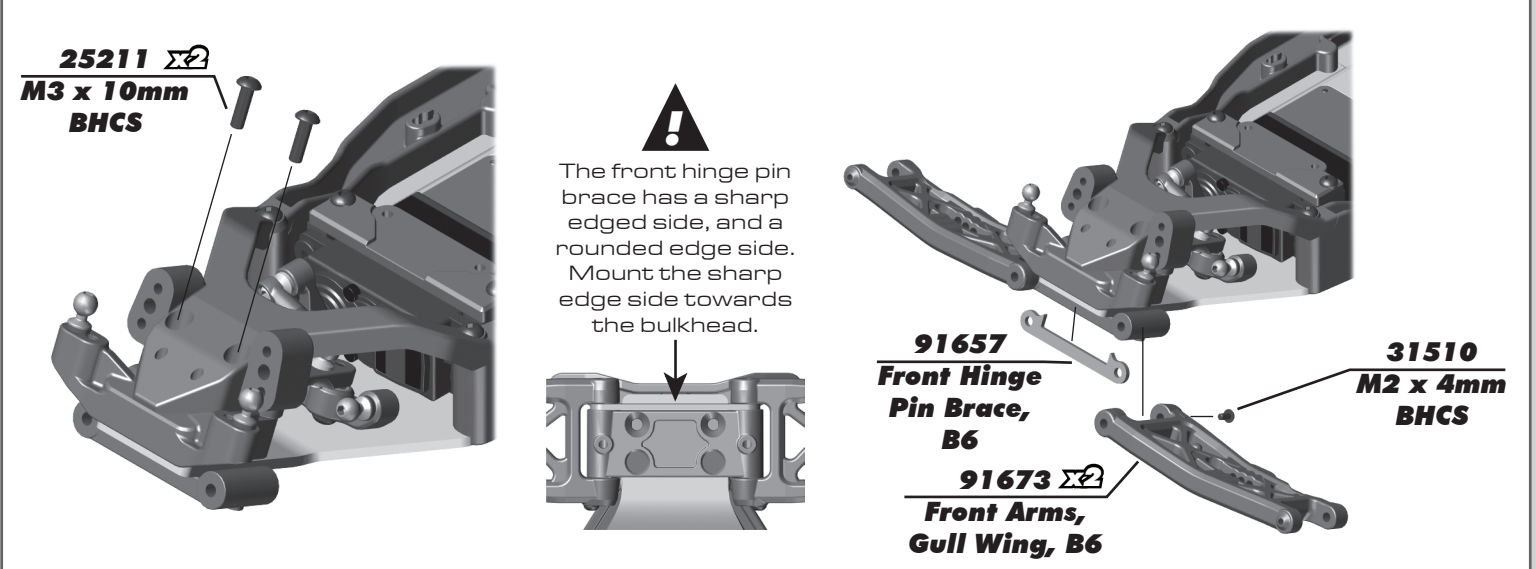

**:: Bag 2 - Step 7**

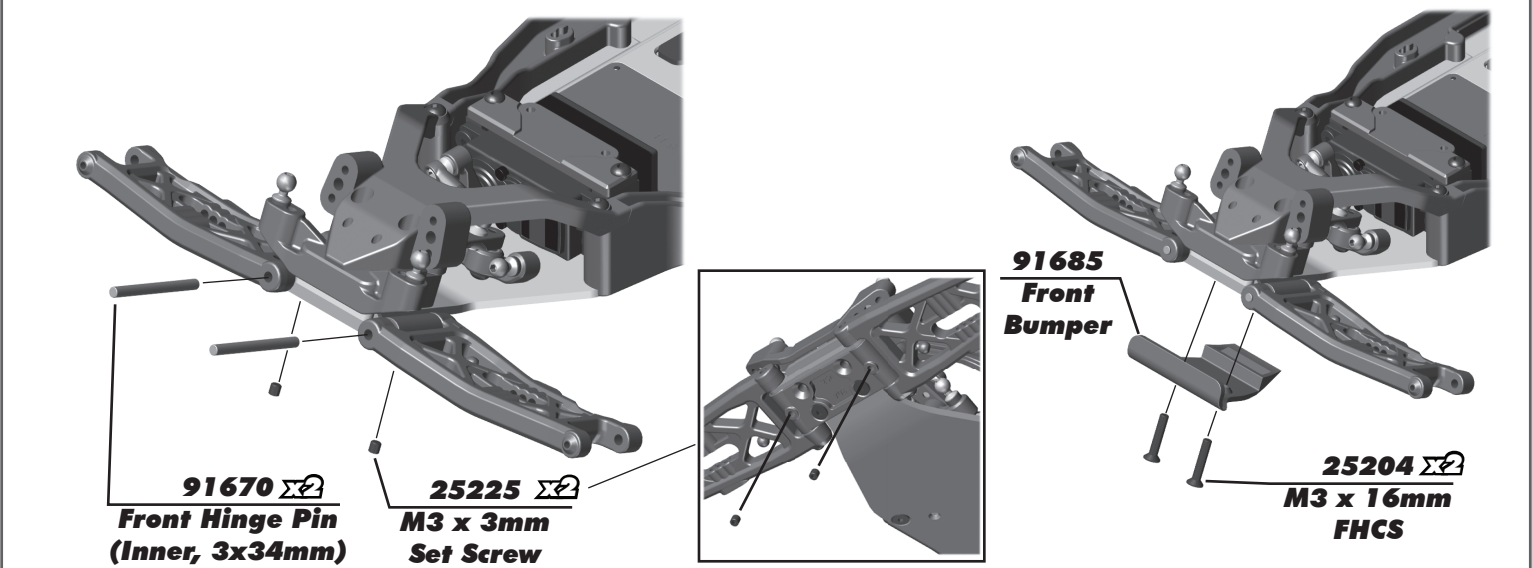

**:: Bag 2 - Step 8**

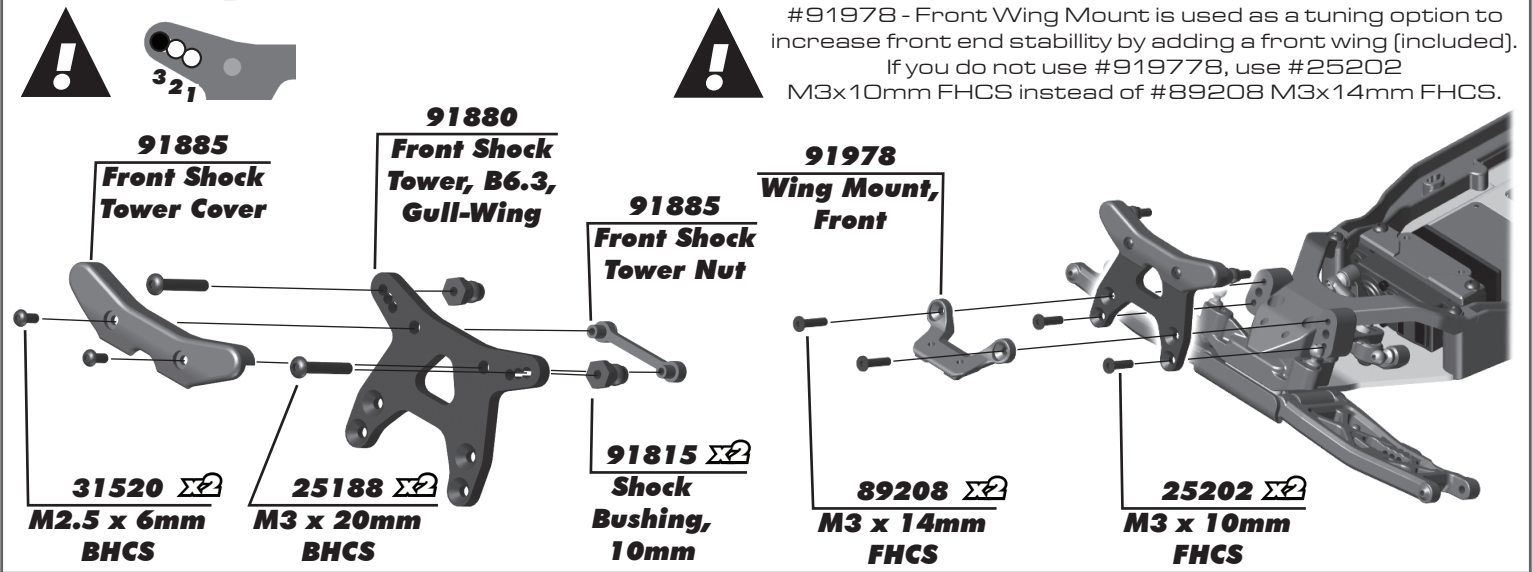

**:: Bag 3 - Step 1**

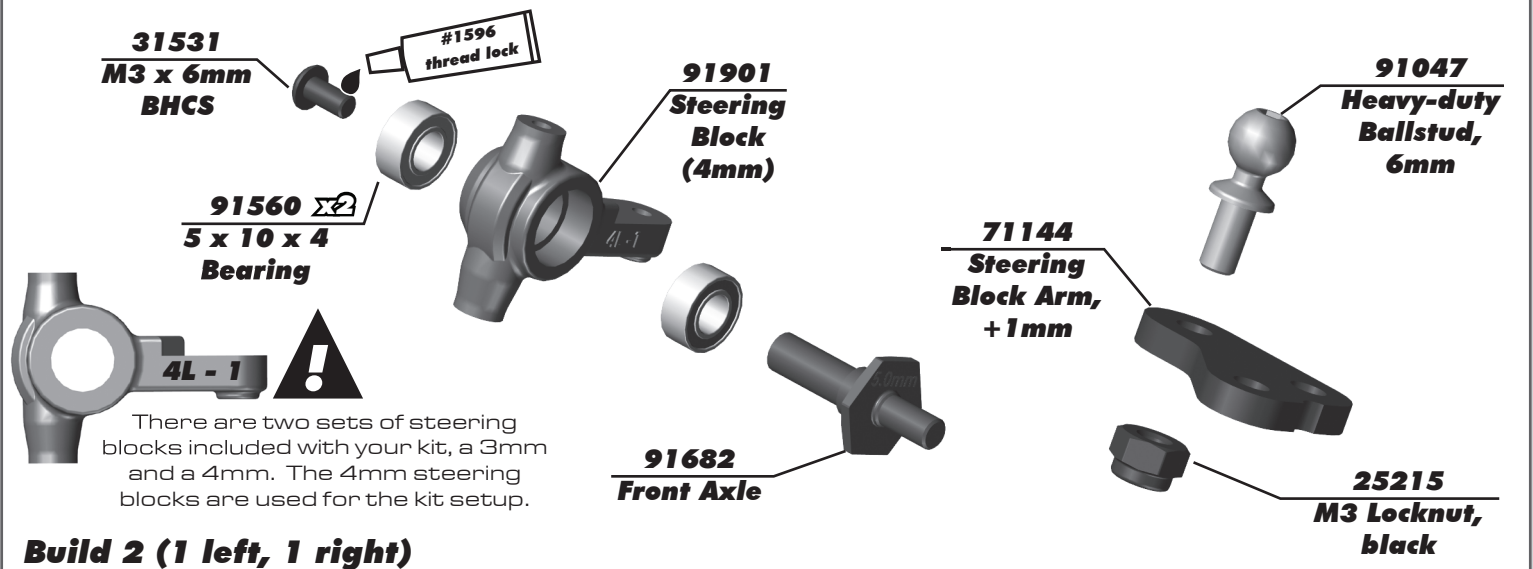

**Build 2 (1 left, 1 right)**



**:: Bag 3 - Step 2**



Use shorter screw in front!

**31531**  
M3 x 6mm  
BHCS

**31532**  
M3 x 8mm  
BHCS

**91049**  
Heavy-duty  
Ballstud,  
10mm

**91901**  
Caster  
Block

**25215**  
M3 Locknut,  
black

You can install an optional #31520 screw to use as a steering stop setting.

You can install an optional #4670 set screw to better hold the caster block inserts and hinge pin.

**91901**  
Caster  
Block Insert  
(+5°)



There are three caster block inserts included [0°, +/-2.5°, +/-5°]. +5° is the standard insert used.  
Tab up = positive caster  
Tab down = negative caster

**Build 2 (1 left, 1 right)**

**:: Bag 3 - Step 3**

**25187**  
M3 x 14mm  
BHCS

**91676**   
Caster Hat  
Bushing  
Top: 2mm  
Bottom: 1mm

**91776**  
Caster Block  
Spacer

**91670**  
Front Hinge Pin  
(Outer, 3x26mm)

**31510**  
M2 x 4mm  
BHCS

**89202**  
M3 x 12mm  
BHCS



#91670 - Hinge Pin will be tight in the caster blocks, but should rotate freely in the front arms.

**Build 2 (1 left, 1 right)**

**Build 2 (1 left, 1 right)**

**:: Bag 4 - Step 1**

Arm Mount C: 1° Out

**91882**  
Aluminum  
Arm Mount, C

**92014**   
Arm Mount  
Inserts  
(1°)

See next step for pill chart tips

**#1596**  
thread lock

**31541**   
M3 x 6mm  
FHCS



You can use a dot of CA glue to better secure the lower shock mounting set screw



11mm

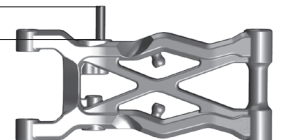

**91737**   
M3 x 20mm  
Set Screw

**91853**   
B6.2 Rear  
Arms, 73mm

**Build 2 (1 left, 1 right)**

**:: Bag 4 - Step 2**

**Arm Mount D:  
1° Out Down**



**92014**  $\Sigma 2$   
**Arm Mount  
Inserts (1°)**

**91685**  
**Rear  
Bumper**

**91883**  
**Aluminum  
Arm Mount, D**

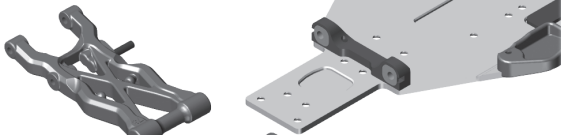

**91853**  $\Sigma 2$   
**Rear Arm  
Spacer**

**91670**  $\Sigma 2$   
**Rear Hinge Pin  
(Inner, 3.5x48mm)**



The (#91882) C and (#91883) D aluminum arm mounts allow for a large amount of setup combinations when using the (#92014) 0.5° and 1° arm mount inserts.

For a complete list of pill setup combinations, please visit our website by using the link below.  
<http://bit.ly/B6PillChart>

	<b>Toe-In</b>	<b>Anti-Squat</b>
<b>Arm Mount C: 1° Out</b> 		
<b>Arm Mount D: 1° Out Down</b> 	<b>3° Kit Setup</b>	<b>2° Kit Setup</b>

**:: Bag 5 - Step 1**

**#6591**  
**diff lube**

**6581**  $\Sigma 14$   
**3/32 Carbide  
Diff Balls**

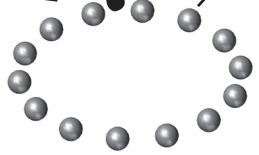

**Build Tip:**

The bottom side of the gear has 3 injection dots. This side faced down will keep the diff balls from falling thru the holes



**91419**  
**Diff Gear,  
52T**

**#6591**  
**diff lube**

**7666**  
**Diff Drive  
Ring**



**#6591**  
**diff lube**

**7666**  
**Diff Drive  
Ring**

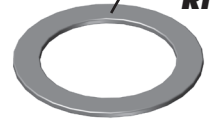

**91701**  
**Ball Diff  
Outdrive**



**91701**  
**Ball Diff  
Outdrive**

**:: Bag 5 - Step 2**

**#6588**  
**black grease**

**91990**  $\Sigma 2$   
**Thrust  
Washer**



**91990**  
**Caged  
Thrust  
Bearing**



**6573**  
**Diff Thrust  
Bolt**



**8680**  
**5 x 8 x 2.5mm,  
Bearing**



**Build Tip:**

Install the first washer (groove up), add grease #6588. Install the caged thrust washer. Add grease on top of the balls, then install the 2nd washer (grooves down).

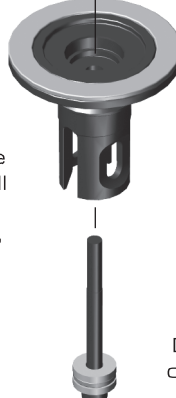

**8680**  
**5 x 8 x 2.5mm,  
Bearing**



**Build Tip:**

Do this entire step with the diff screw on the end of your wrench for better control.

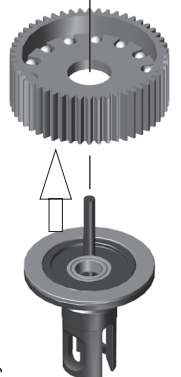

**:: Bag 5 - Step 3**

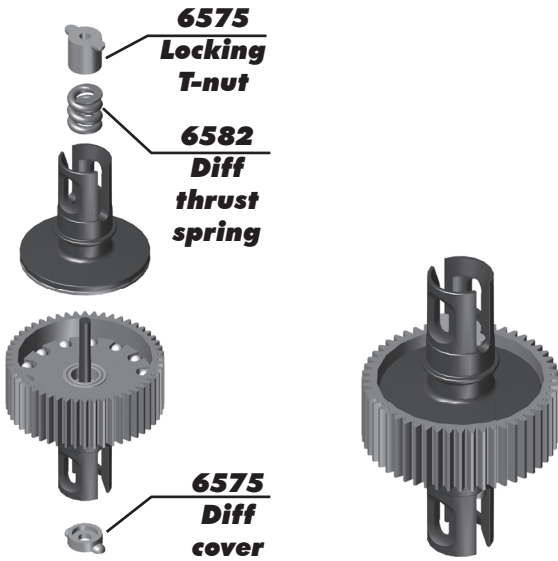

As you tighten the diff bolt, you will notice the T-nut ears moving closer to the bottom of the outdrive slot. This compresses the spring behind the T-nut. The spring should be completely compressed at the time the T-nut reaches the end of the slot. Caution! Pay close attention to the feeling when the spring is completely compressed. Do not overtighten the bolt. When you feel the spring completely compressed, loosen the diff bolt 1/8 of a turn. Your diff should now operate smoothly but with resistance as the outrives move in opposite directions. After you have driven the car once, re-check the diff setting.

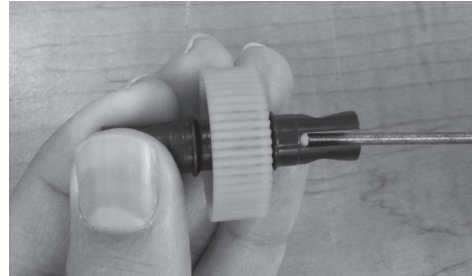

**:: Optional Anti-Roll Bar Build - NOT INCLUDED**

**NOT INCLUDED**

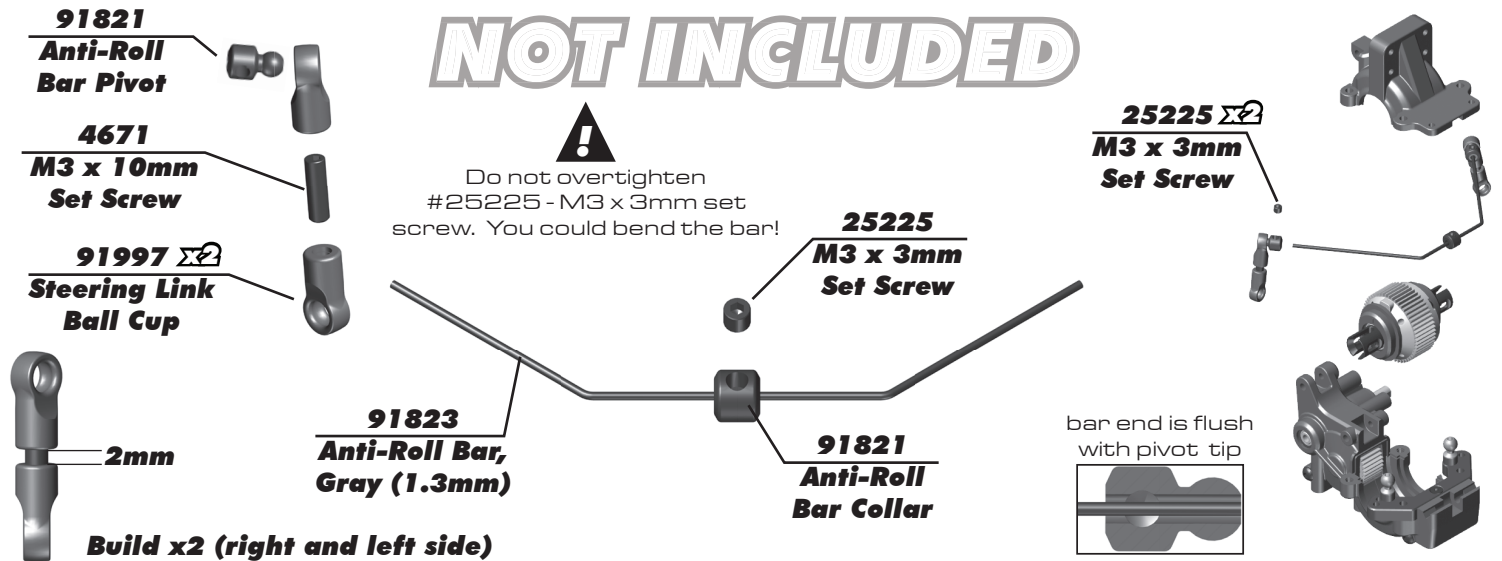

**:: Bag 6 - Step 1**

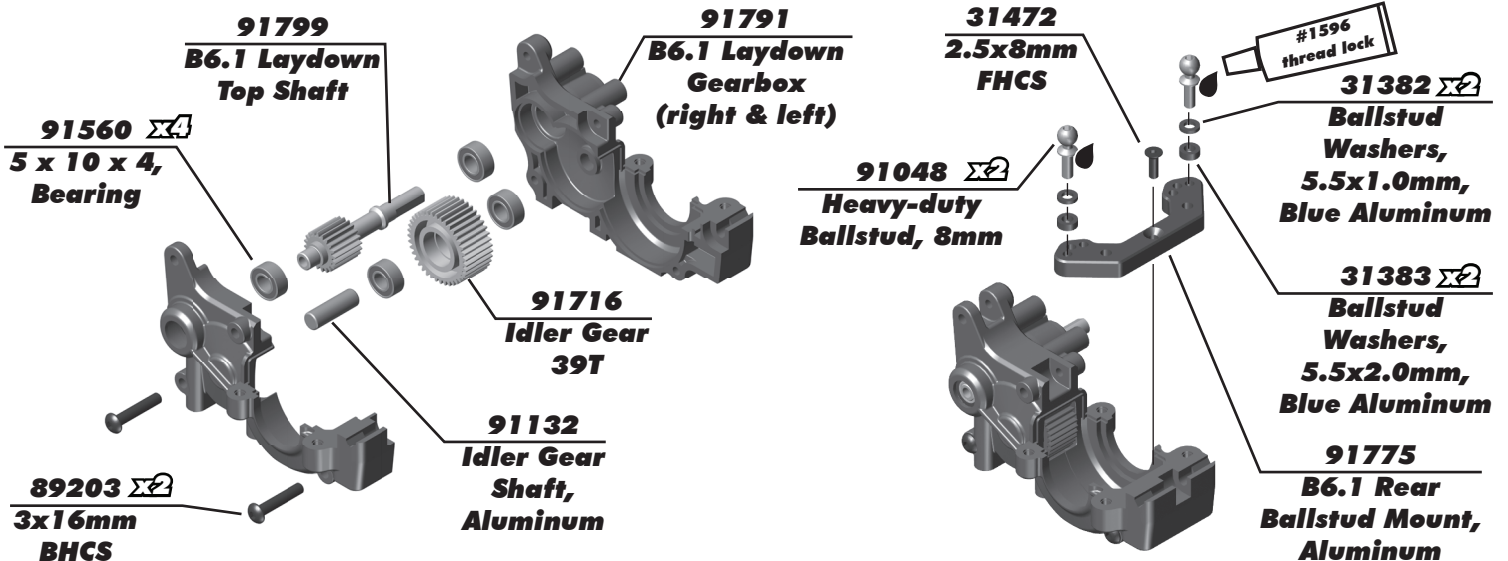

**:: Bag 6 - Step 2**

Diff Height	
	<b>3</b>
	<b>2 Kit Setup</b>
	<b>1</b>
	<b>0</b>

**!**  
Add a drop of Diff Lube [#6591] to the teeth of the diff gear, idler gear, and top shaft.

**91563**   
**10x15x4 Bearing**

**91791**  
**B6.1 Laydown Gearbox Top**

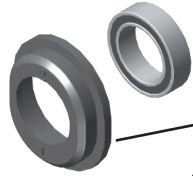

**91792**   
**B6.1 Diff Height Insert**

**!**  
Diff Height Inserts:  
The number on top is the setting.  
Stock diff height is 2.

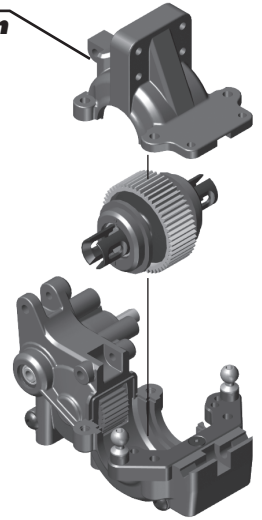

**:: Bag 6 - Step 3**

**89202**   
**3 x 12mm BHCS**

**89203**   
**3 x 16mm BHCS**

**91709**  
**Laydown Chassis Brace**

**91819**  
**B6.1 Shock Pivot Ball**

**89203**  
**3 x 16mm BHCS**

**25188**  
**3 x 20mm BHCS**

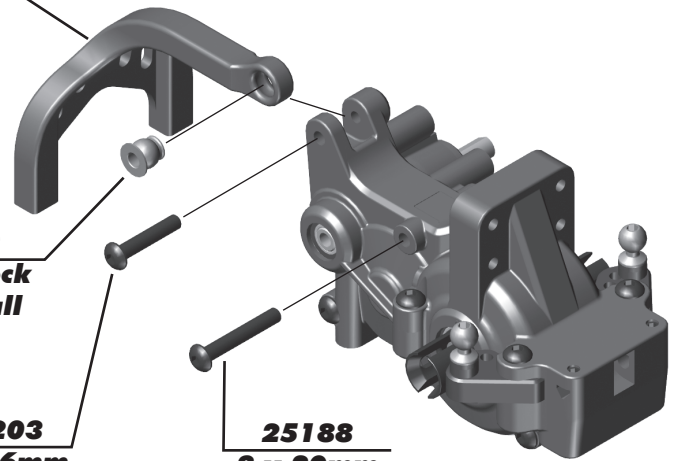
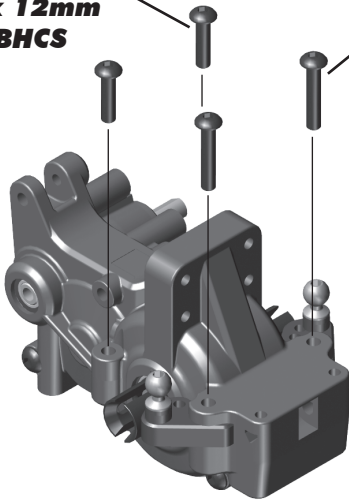

**:: Bag 6 - Step 4**

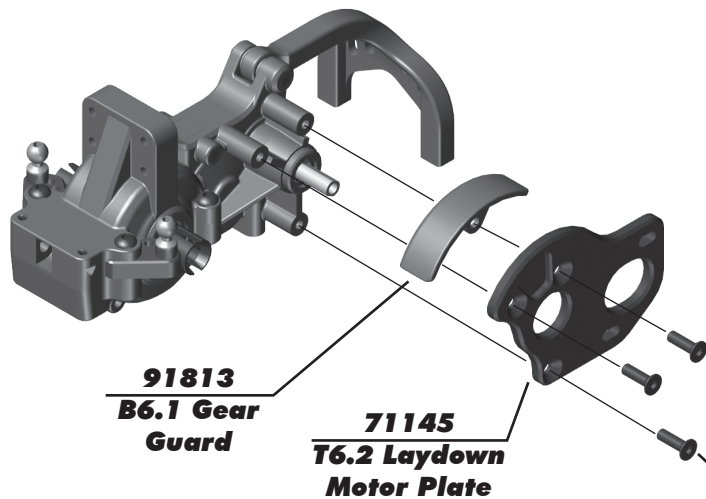

**91813**  
**B6.1 Gear Guard**

**71145**  
**T6.2 Laydown Motor Plate**

**25202**   
**3 x 10mm FHCS**

**91803**  
**B6.1 Slipper Hub, Inner**

**92295**  
**Octalock Spur Gear, 78T 48P**

There's also a 72T, 48P spur gear [#92293] included for stock motor use!

**92286**   
**FT Octalock LCF Slipper Pad, 19mm**

**!**  
#92295 spur gear walls should point away from gear box.

**91804**  
**B6.1 Slipper Hub, Outer**

**91799**  
**B6.1 Top Shaft Screw and Pin**



**:: Bag 6 - Step 5**

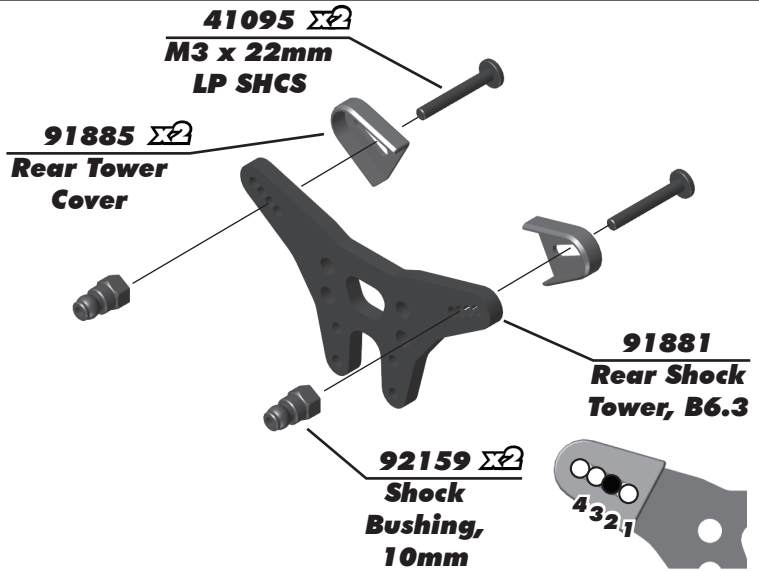
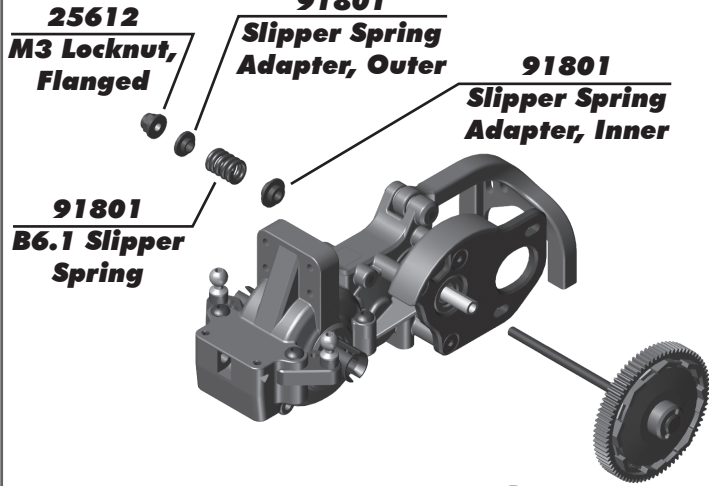

**!** See page 20 for gear mesh, and slipper clutch setting instructions!

**!** Set nut flush with top shaft.

**:: Bag 6 - Step 6**

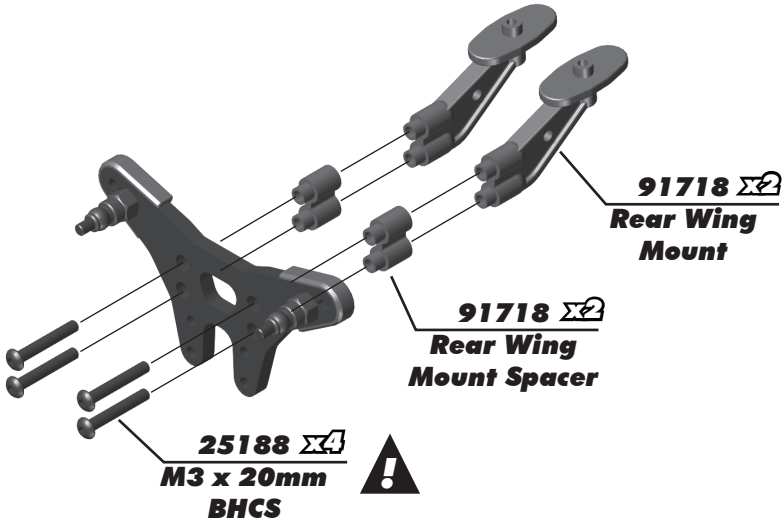

**!** #25188 x4 (M3x20mm)  
#89202 x4 (M3x12mm)

**!** \*use 12mm length screws if rear wing mount spacer is removed.

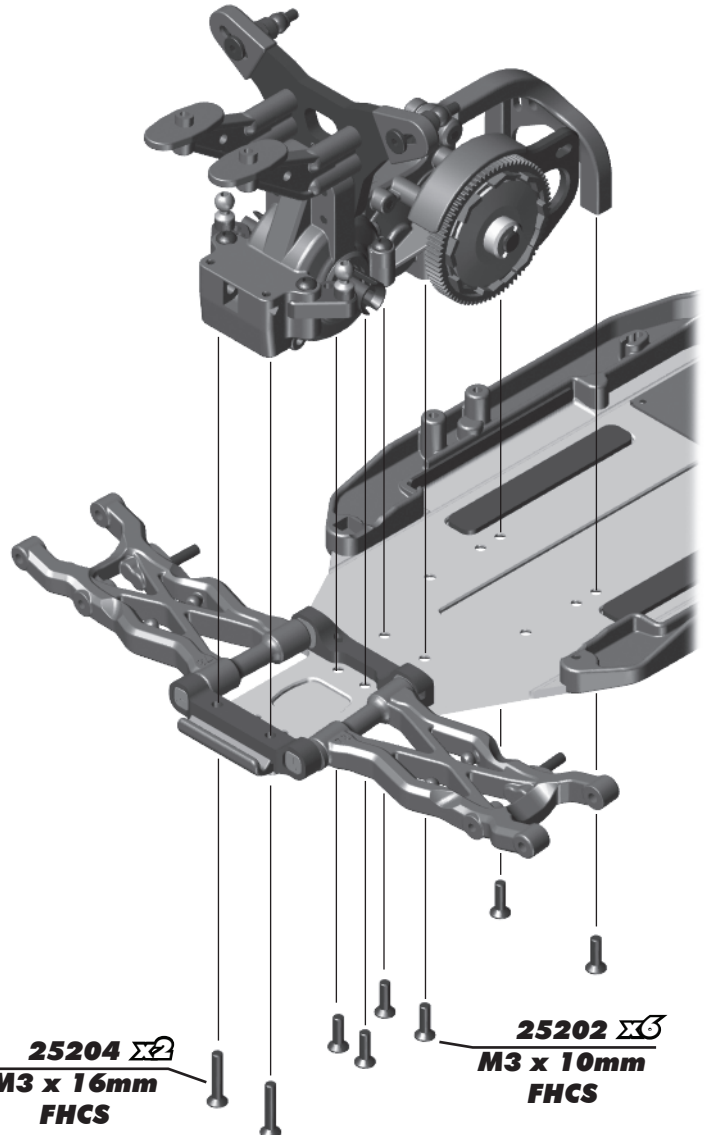
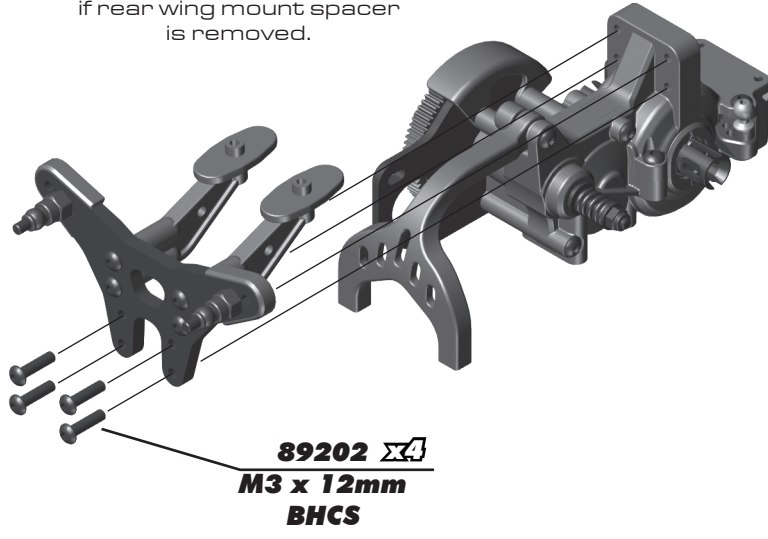

**:: Bag 7 - Step 1**

**91047**  
Heavy-duty  
Ballstud,  
6mm

#1596  
thread lock

**31383**  
Ballstud Washers,  
5.5x2.0mm, blue

**31382**  
Ballstud Washers,  
5.5x1.0mm, blue

**92179**  
Rear Hub  
Inserts

**92180**  
Rear Hub  
Link Mounts

**91857**  
B6.2 Rear  
Hubs

#1596  
thread lock

**89202**  
M3 x 12mm  
BHCS

**Build x2 (right and left side)**

Rear Axle Height			
↑ 3	0 ↓		3 ↑ +3mm
↑ 2	1 ↓		2 ↑ +2mm Kit Setup
↓ 2	1 ↑		1 ↑ +1mm
↓ ε	0 ↑		0 ↑ +0mm

**:: Bag 7 - Step 2**

**91438**  
CVA  
Coupler

#6588  
black grease

**91860**  
CVA Bone,  
69mm

**91438**  
CVA Pin

**91859**  
B6.2 CVA  
Axle, +2mm

**91563**  
10 x 15 x 4  
Bearing

**91567**  
5 x 12 x 4  
Bearing

Note the location  
of the "L" and "R"  
on the rear hub!

**Build x2**

**Build x2 (right and left side)**

**:: Bag 7 - Step 3**

**91436**  
CVA Wheel  
Hex Pin

**91609**  
Clamping Wheel  
Hex, 5mm Offset  
(rear)

**91611**  
M1.6 x 5mm  
SHCS

**25215**  
M3 Locknut

**92188**  
Rear Hub  
Hinge Pin

**92179**  
Rear Hub  
Spacer

Do not overtighten the  
1.6 x 5mm SHCS into the  
Clamping wheel hex.

Hinge Pin will be tight in  
the rear hub, but should  
rotate freely  
in the rear arms.

**Build x2 (right and left side)**

**Build x2 (right and left side)**

**:: Bag 8 - Step 1**

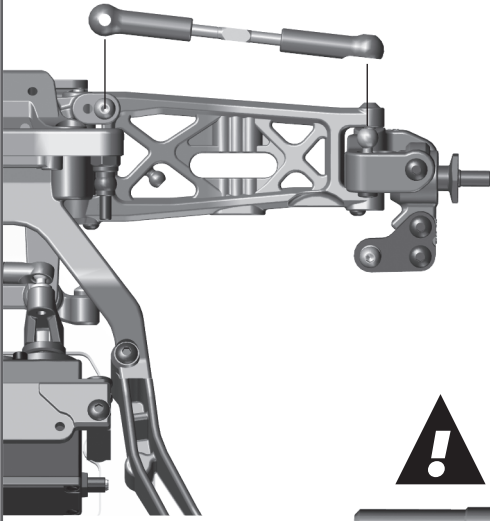

Racers Tip:

Use black grease (#6588) on the threads of the turnbuckles for easier ball cup installation!



Orient the notch to the left throughout the car. It indicates which end has the left hand threads!



**91722**  
**Ball Cup**

**91723**  
**Turnbuckle**  
**3x48mm**

**91722**  
**Ball Cup**

**Front Camber Turnbuckle**  
**22.50mm**



**Build x2 (right and left side)**

**:: Bag 8 - Step 2**

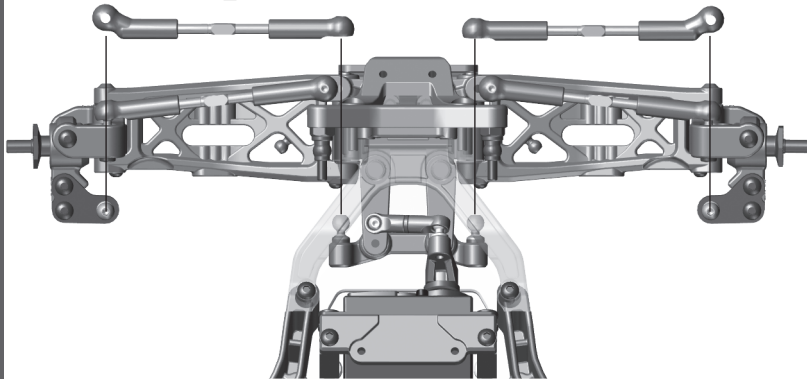

Letter L/R on plastic will be reversed when installed, follow the image!

Orient the notch to the left throughout the car. It indicates which end has the left hand threads!

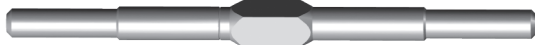

**91722**  
**Ball Cup**

**91723**  
**Turnbuckle**  
**3x48mm**

**91722**  
**Ball Cup**

**Steering Turnbuckle**  
**27.90mm**



**Build x2 (right and left side)**

**:: Bag 8 - Step 3**

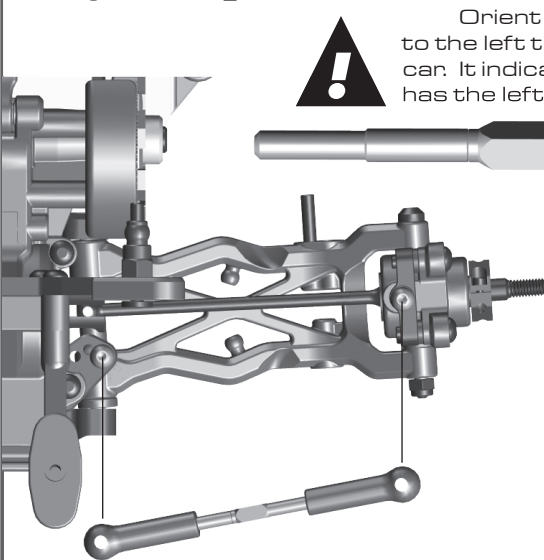

Orient the notch to the left throughout the car. It indicates which end has the left hand threads!



**91722**  
**Ball Cup**

**91723**  
**Turnbuckle**  
**3x48mm**

**91722**  
**Ball Cup**

**Rear Camber Turnbuckle**  
**24.20mm**



**Build x2 (right and left side)**

**:: Bag 9 - Step 1**

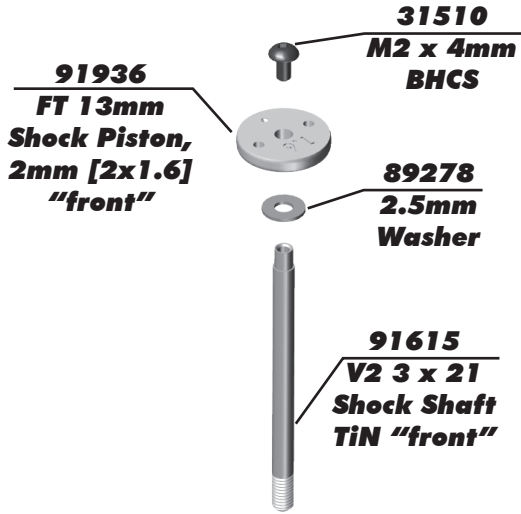

**Build x2 front shocks**

**!**  
Mount the shock pistons with the number facing up!



Racers Tip:

Use a marker over the numbers on the pistons to make them easily visible!

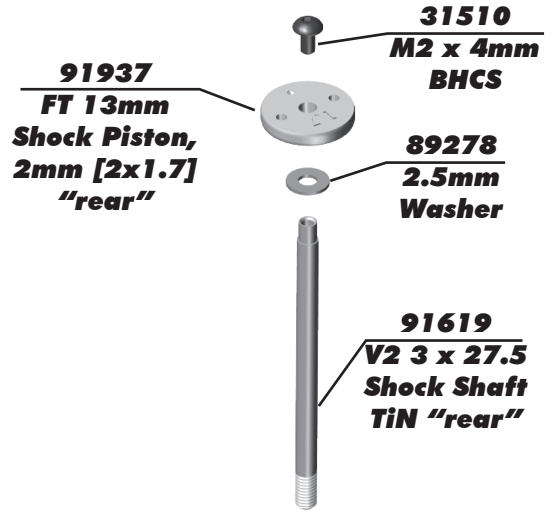

**Build x2 rear shocks**

**:: Bag 9 - Step 2**

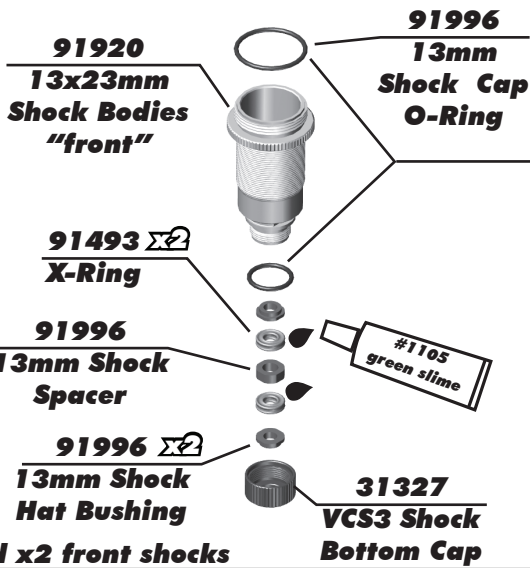

**Build x2 front shocks**

**!**  
Lightly rub shock oil on the O-ring before installation!



Racers Tip:

Coating the O-rings with green slime (#1105) helps seal & reduce O-ring swell! **Green slime not included in kit!**

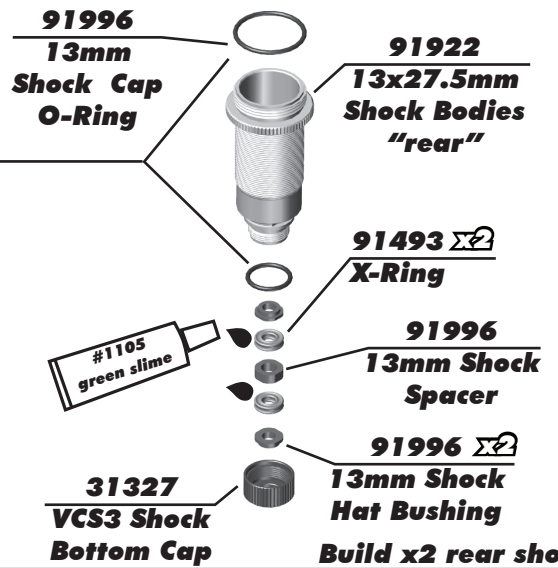

**Build x2 rear shocks**

**:: Bag 9 - Step 3**



**!**  
Lightly rub shock fluid or green slime on threads

**!**  
There are 3 lengths of shock eyelet in the kit. Pay attention to length when building as these affect your droop and uptravel.

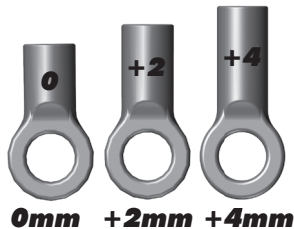

**Build x2 front shocks**



**Build x2 rear shocks**



**:: Bag 9 - Step 4**

**Front Shock: 30wt #5422**  
**Rear Shock: 30wt #5422**

**Steps 2-3**    **Steps 4-5**    **Steps 6-7**    **Step 8**

**91926 13mm Shock Cap**

**Shock Bleeding Steps:**

1. Before assembly, get each bleed screw and thread it 1-2 turns into the shock cap, then remove the screw. This will make it easier when you are bleeding your shocks.
2. Pull shock shaft down.
3. Fill shock body 3/4 full with silicone shock fluid.
4. Slowly move the shock shaft up and down to remove air from under the piston.
5. Wait for bubbles to come to surface.
6. Fill shock body to top with silicone shock fluid.
7. Place a drop of oil in the cap and on cap threads.
8. Install cap (without bleed screw) and tighten completely.
9. Slowly compress shaft all the way to bleed excess silicone shock fluid out the hole in the cap (use rag around shock to catch excess fluid).
10. Install M2x4mm button head screw until snug while shaft is fully compressed.

**31510 M2 x 4mm BHCS**

Stroke

**Stroke Front: 21mm**  
**Rear: 27.5mm**

**Steps 9-10**

**:: Bag 9 - Step 5**

**91996 x4 13mm Threaded Collar O-ring**

**91928 x4 13mm Threaded Collar**

**Build x4**

**Racers Tip:**  
Use your finger to rub shock fluid on the O-ring for smoother adjustment!

**91941 13mm Front Spring, Gray (3.40lb)**

**91948 13mm Rear Spring, White (1.90lb)**

**:: Bag 9 - Step 6**

**Front: 4.50mm**

**91926 13mm Shock Spring Cup "Front - 5mm"**

**Build x2 front shocks**

**Rear: 6.50mm**

**91926 13mm Shock Spring Cup "Rear - 0mm"**

**Build x2 rear shocks**

**#91926 13mm Shock Spring Cups**

**0mm    5mm    9mm**

**:: Bag 9 - Step 7**



Use outside hole in front arm!

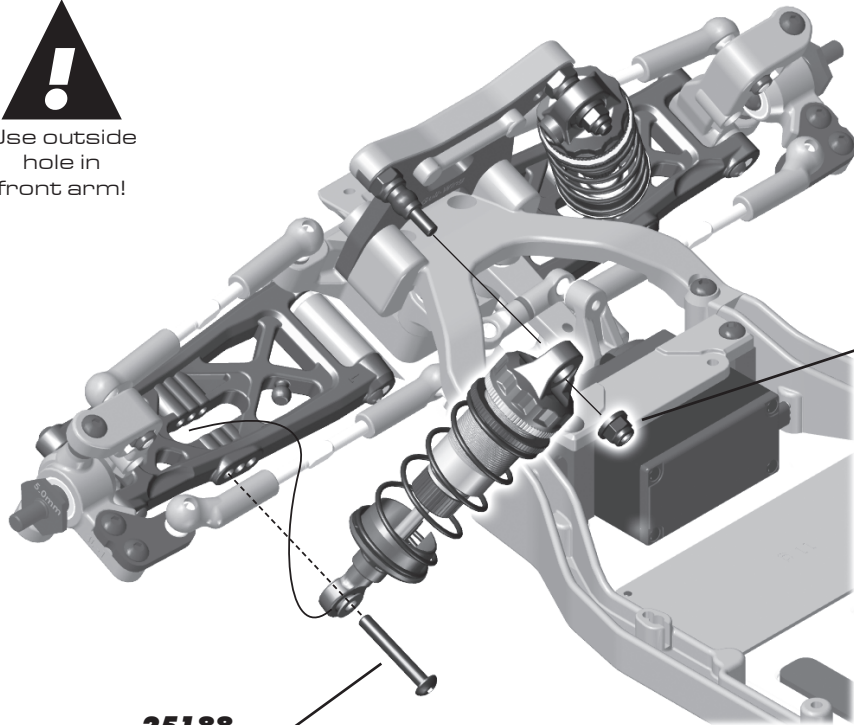

**25188**  
M3 x 20mm  
BHCS

**25612**  
M3 Locknut  
w/Flange

**Build x2 (right and left side)**

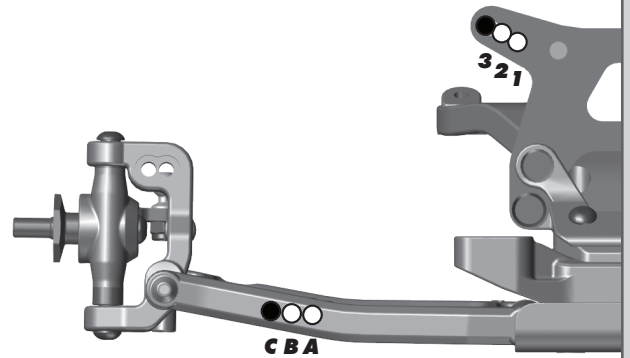

**:: Bag 9 - Step 8**



Make sure the flange on the shock pivot ball is towards the rear arm.

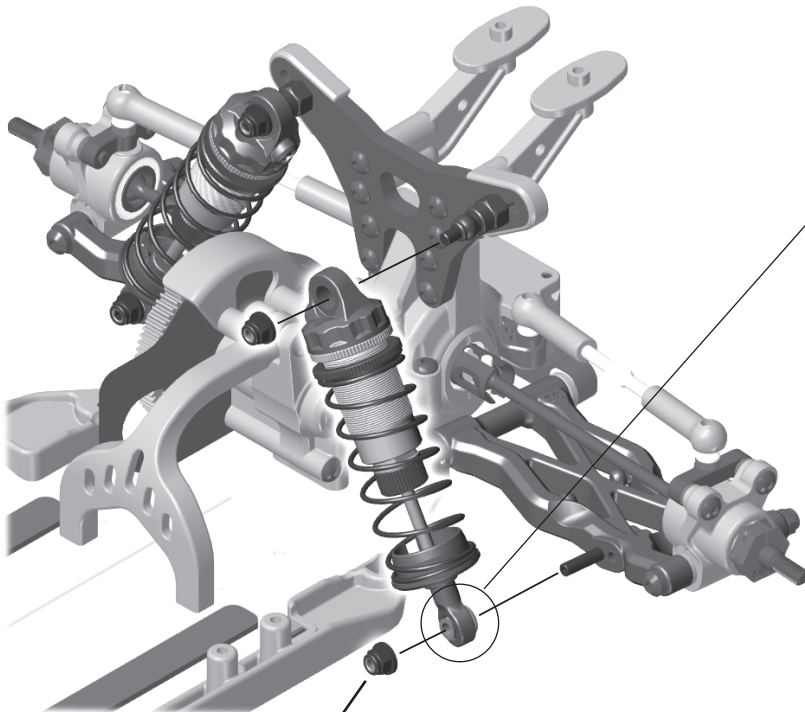

**25612 x2**  
M3 Locknut  
w/Flange

**Build x2 (right and left side)**

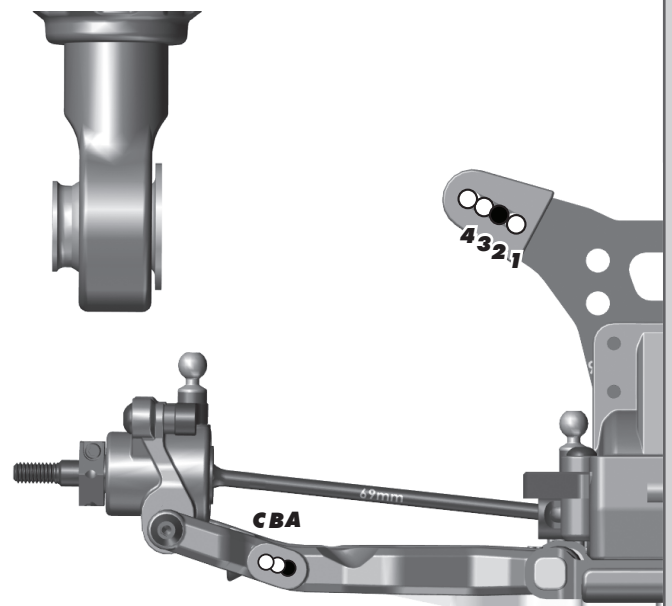

**:: Bag 10 - Step 1**



See page 25 for gear mesh setting instructions!

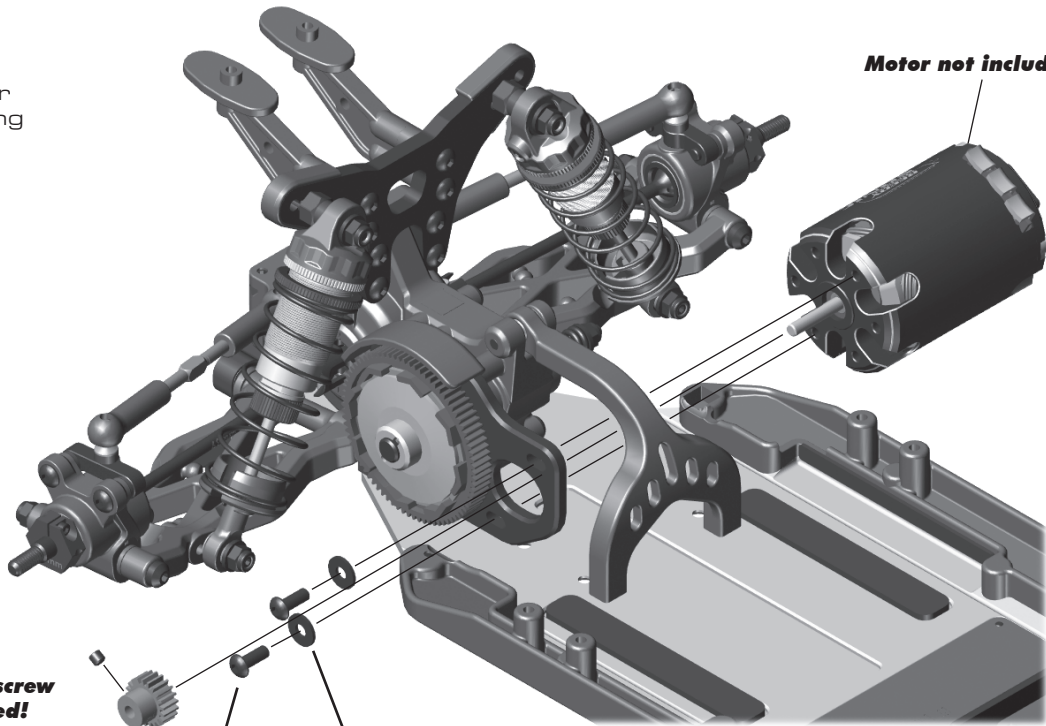

**Motor not included!**

**Pinion & Setscrew not included!**

**31532**   
**M3 x 8mm**  
**BHCS**

**89218**   
**3 x 8mm**  
**Washer**

**:: Bag 10 - Step 2**



Fan mount options:  
 #1 - Laydown gearbox  
 #2 - Layback gearbox  
 #3 - Endbell location  
 #4 - Plug (no fan)

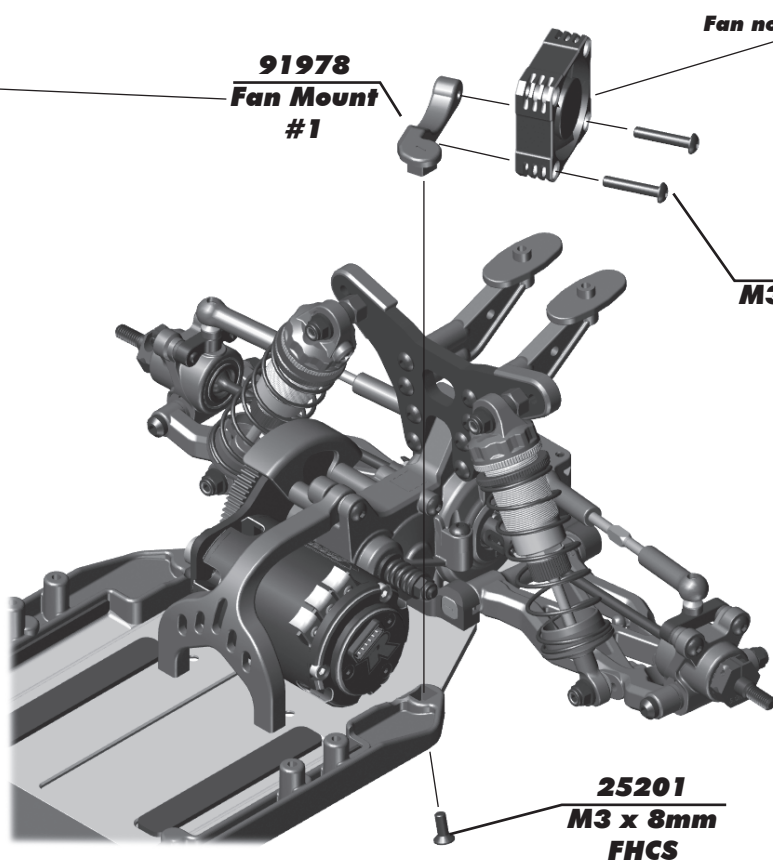

**Fan not included!**

**91978**  
**Fan Mount**  
**#1**

**89203**  
**M3 x 16mm**  
**BHCS**

**25201**  
**M3 x 8mm**  
**FHCS**

**:: Bag 10 - Step 2**

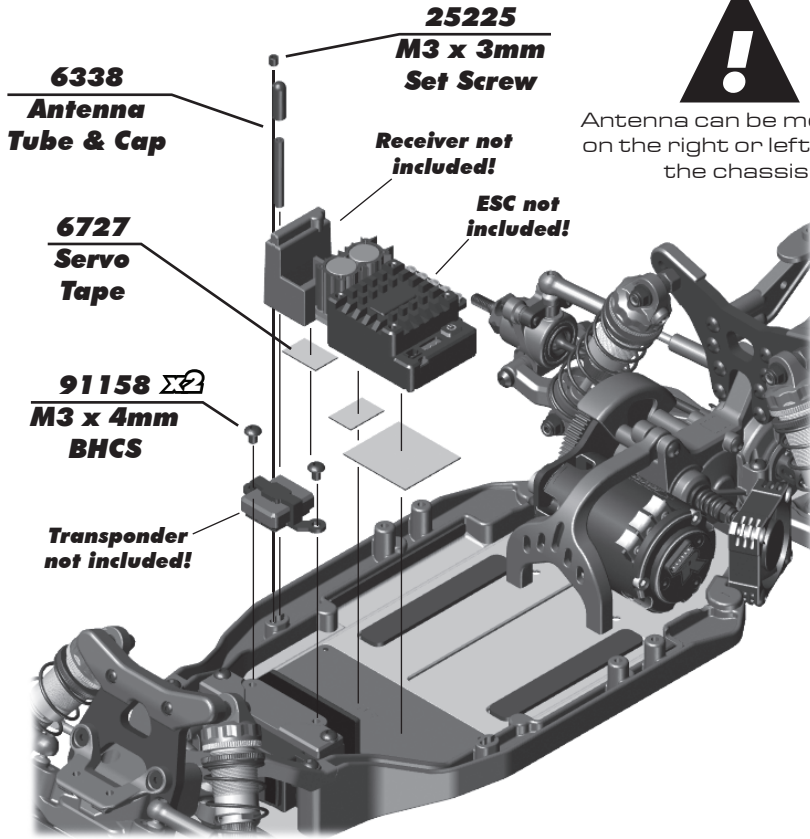

Antenna can be mounted on the right or left side of the chassis.

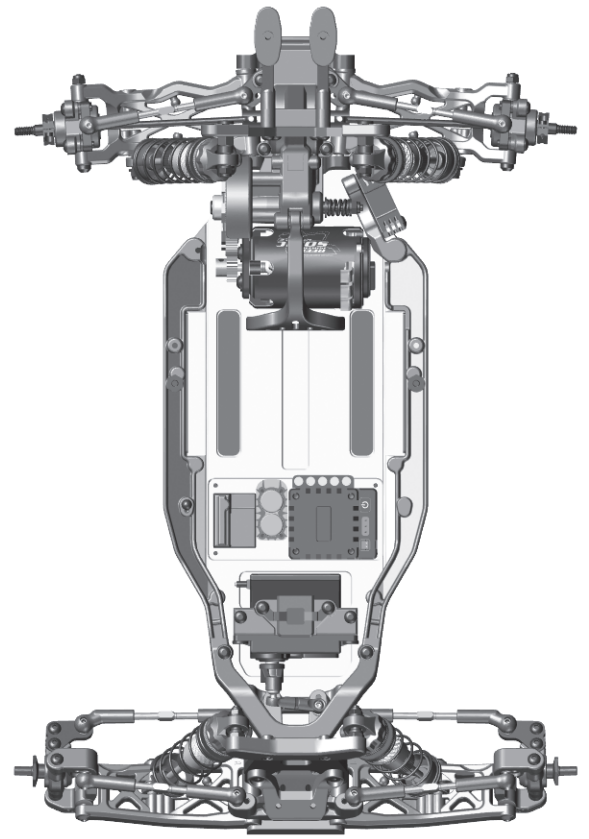

**:: Bag 10 - Step 3**

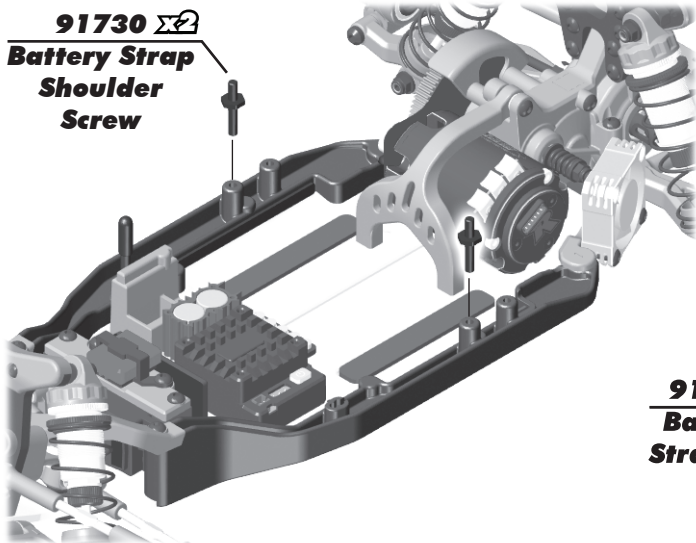

Make sure the battery strap shoulder screw is flush with the top of your battery pack!

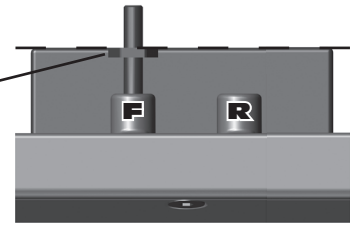

**91731 Battery Strap, B6**

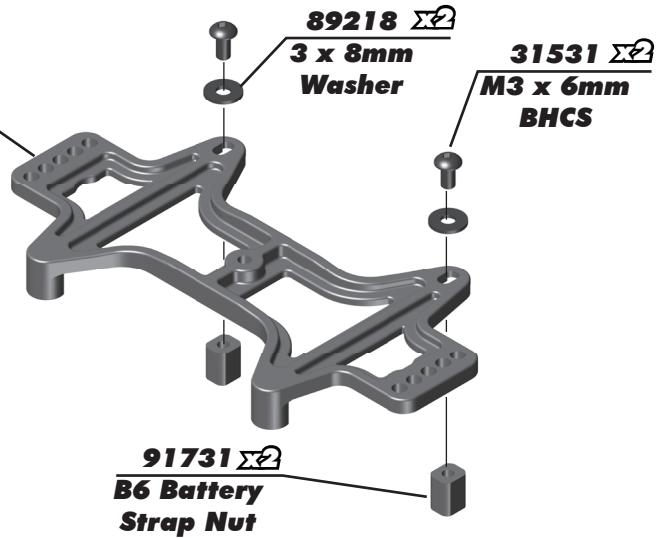

**:: Bag 10 - Step 4**

**Front**

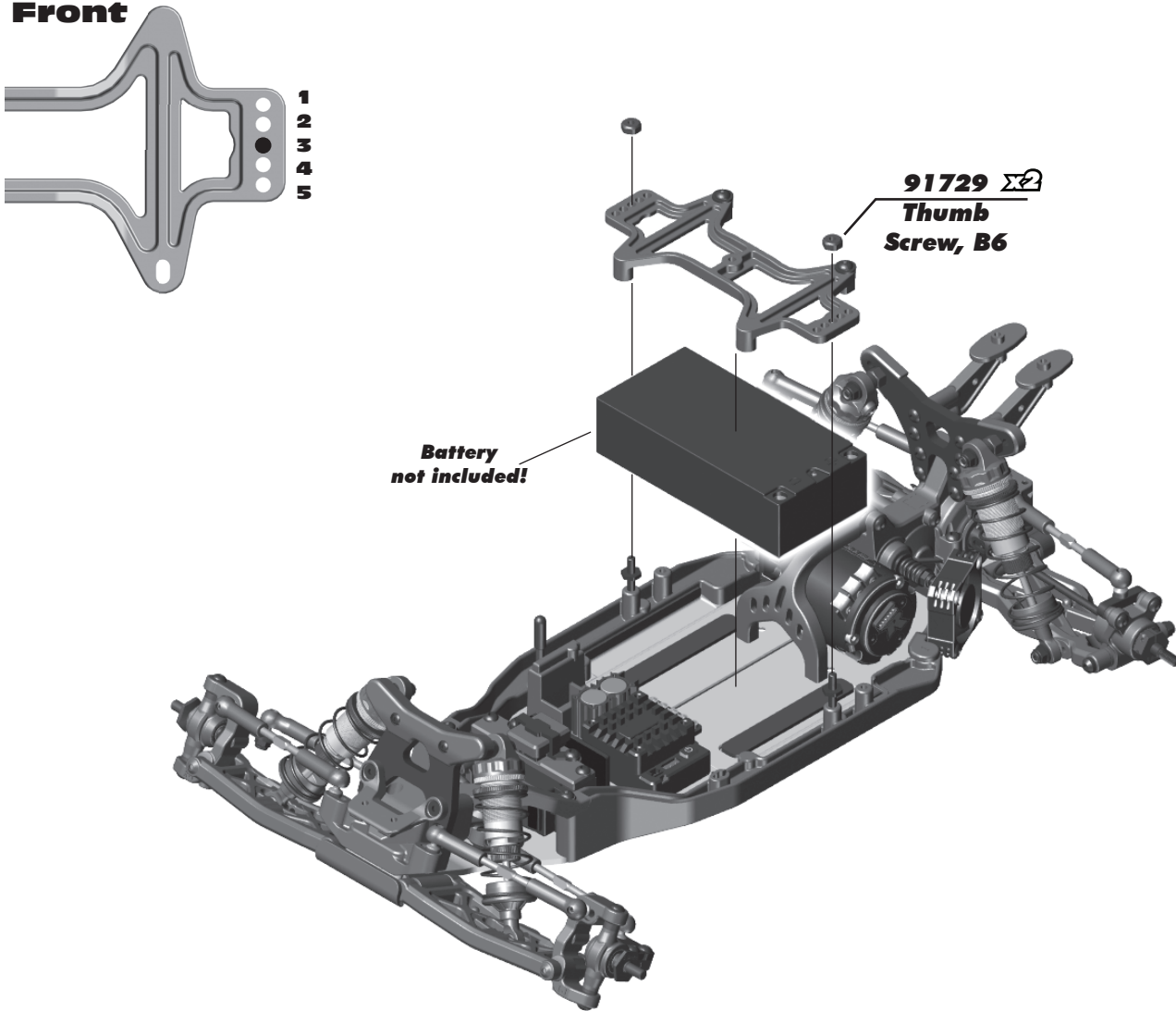

**:: Bag 10 - Step 5 - Optional Chassis Brace Configuration**

**91885**  
**Rod End**

**91723**  
**Turnbuckle**  
**3x48mm**

**91885**  
**Rod End**

**25612**  
**M3 LockNut**  
**w/Flange**

**91819** **Shock**  
**Pivot Ball**

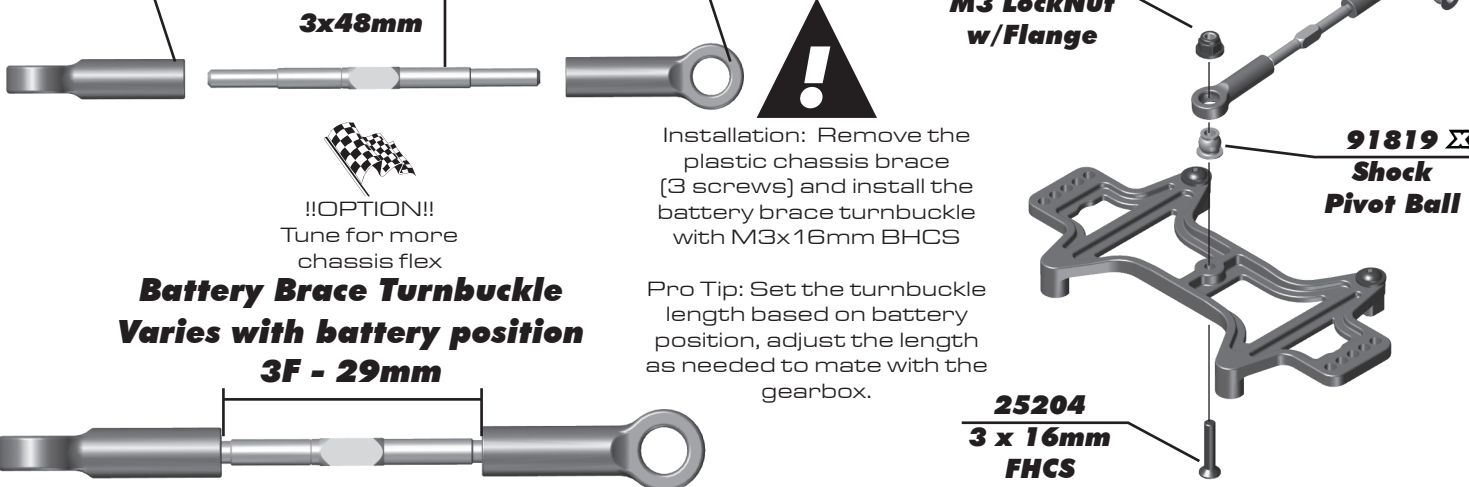

**:: Bag 10 - Step 6**

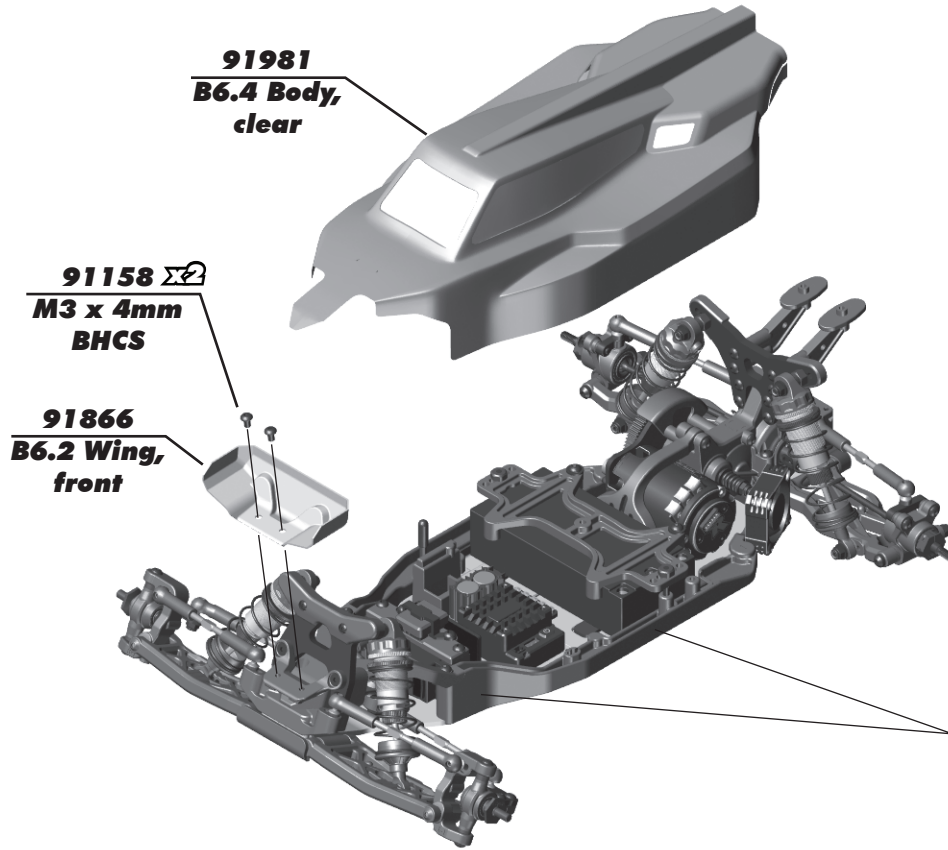

**91981**  
**B6.4 Body,**  
**clear**

**91158**  $\times 2$   
**M3 x 4mm**  
**BHCS**

**91866**  
**B6.2 Wing,**  
**front**



Install hook and loop tape [#91743] along the side braces in 2 spots. One near the front, and one in the middle. Install the opposite side of the hook and loop tape inside the body!

**:: Bag 10 - Step 7**



Trim the front edge of the wing straight. Trim lines for shock clearance used ONLY for shocks mounted on the rear of the arms.

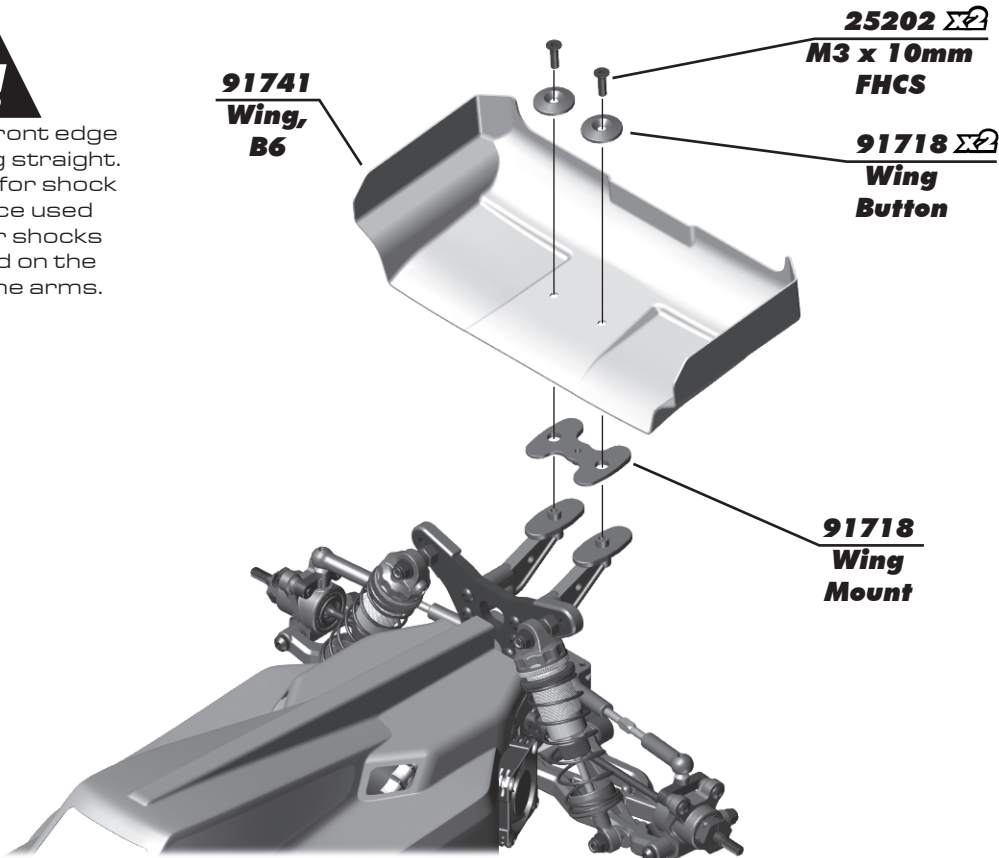

**91741**  
**Wing,**  
**B6**

**25202**  $\times 2$   
**M3 x 10mm**  
**FHCS**

**91718**  $\times 2$   
**Wing**  
**Button**

**91718**  
**Wing**  
**Mount**

**Wing Mount**



6° - Mount under wing - KIT



3° - Mount on top of wing



0° - Mount under wing

**Front of Vehicle**



**:: Bag 10 - Step 8**

**Body Trimming / Mounting:**

There are 2 body trimming options depending on what transmission you choose to run.

- Cut Line A is for #3 endbell or #4 no fan
- Cut Line B is for running a fan # 1 or #2 location.

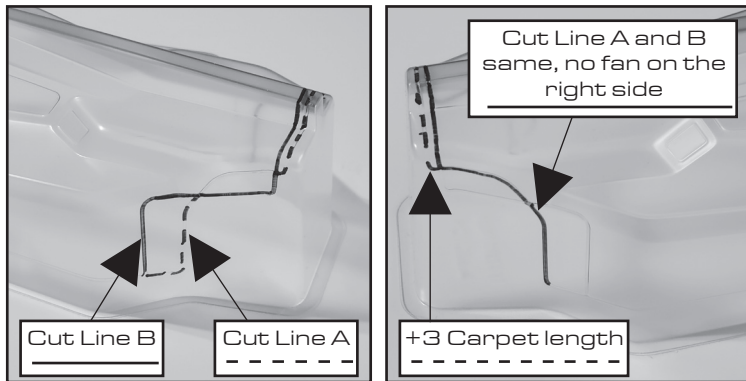

**Body Trimming for Length:**

There are 2 body trimming options depending on what transmission you choose to run.

- Cut the body on the top/rear, long for the B6.4, shorter for the B6.4D

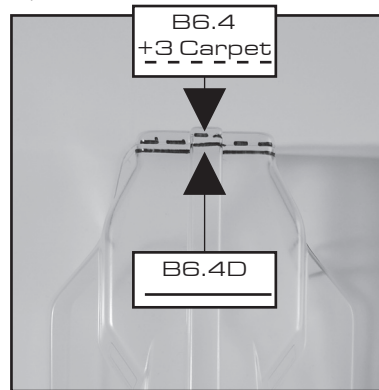

**:: Bag 10 - Step 9**



**:: Bag 10 - Step 10**



## :: Tuning Tips

### Painting:

Your Kit comes with a clear polycarbonate body. You will need to prep the body before you can paint it. Wash the INSIDE thoroughly with warm water and liquid detergent (do not use any detergents with scents or added hand lotion ingredients!). Dry the body using a clean, soft, lint-free cloth. Use the supplied window masks to cover the windows from the INSIDE of the body (RC cars get painted on the inside). Using high quality masking tape, apply tape to the inside of the body to create a design. Spray (use either rattle can or airbrush) the paint on the inside of the body (preferably dark colors first, lighter colors last). NOTE: ONLY use paint that is recommended for polycarbonate plastics. If you do not, you can destroy the body! After the paint has completely dried (usually after 24 hours), cut the body along the trim lines. Make sure to drill or use a body reamer to make the holes for the antenna if needed! Use hook and loop tape to secure the body to the side rails of the vehicle.

### Tips for Beginners:

Before making any changes to the standard setup, make sure you can get around the track without crashing. Changes to your vehicle will not be beneficial if you can't stay on the track. Your goal is consistent laps. Once you can get around the track consistently, start tuning your vehicle. Make only ONE adjustment at a time, testing it before making another change. If the result of your adjustment is a faster lap, mark the change on the included setup sheet (make additional copies of the sheet before writing on it). If your adjustment results in a slower lap, revert back to the previous setup and try another change. When you are satisfied with your vehicle, fill in the setup sheet thoroughly and file it away. Use this as a guide for future track days or conditions. Periodically check all moving suspension parts. Suspension components must be kept clean and move freely without binding to prevent poor and/or inconsistent handling.

### Rear Arm Mount Pill Insert Setup:

The aluminum rear arm mounts utilize eccentric pill inserts to make fine adjustments to anti-squat, toe, pin heights, and pin width. Adjustments can be made using the supplied inserts (#92014)

#### Standard Position

Use this position as a reference when changing pill locations.

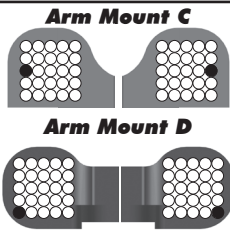

Toe: 3°  
Anti-squat: 2°  
Roll Center: +0  
Pivot Width: +0

#### Insert Hole Locations

Number indicates degree of change:  
0.5°, 1.0°, 0° (center dot)

- 0.5: Hole 0.5° or 0.35mm from center
- 1: Hole 1.0° or 0.7mm from center

### Anti-squat Angle

More angle = More anti-squat  
Less angle = Less anti-squat  
Shown in 1° changes

C Mount	D Mount	
		+ 1°
		= 0°
		= -1°
		= 2°
		= 1°
		= 0°
		= -3°
		= -2°
		= 1°

#### Possible Insert Locations

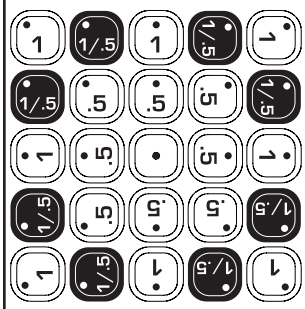

#### Pin Width

More distance = wider pivot  
Less distance = narrow pivot  
\*Note: For pin width -1.4mm, use 67mm CVA driveshafts

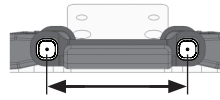

C Mount	D Mount	
		= +1.4mm
		= +0.7mm
		= 0mm
		= -0.7mm
		= -1.4mm*

### Toe Angle

More angle = More toe in  
Less angle = Less toe in  
Shown in 1° changes

C Mount	D Mount	
		= 3°
		= 4°
		= 5°
		= 2°
		= 3°
		= 4°
		= 1°
		= 2°
		= 3°



For additional setup tips, please visit our website by using the link or QR code below.

<http://bit.ly/B6PillChart>



#### Pin Height

Higher pin = Higher roll center  
Lower pin = lower roll center

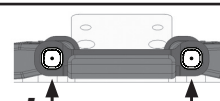

C Mount	D Mount	
		= +0.7mm
		= +0.35mm
		= 0mm
		= -0.35mm
		= -0.7mm



## :: Tuning Tips (cont.)

### Motor Gearing:

Proper motor gearing will result in maximum performance and run time while reducing the chance of overheating and premature motor failure. The gear ratio chart lists recommended **starting gear ratios** for the most widely used motor types. Gear ratios will vary depending upon motor brand, wind, and electronic speed control. Consult your motor and electronic speed control manufacturers for more information.

Team Associated is not responsible for motor damage due to improper gearing.

#### B6 Gear Ratio Chart (Internal Gear Ratio 2.60:1)

Motor	Pinion	Spur	Final Drive Ratio
21.5 Reedy S-Plus Brushless	33	72	5.67:1
17.5 Reedy S-Plus Brushless	29	72	6.45:1
13.5 Reedy S-Plus Brushless	27	*75	7.22:1
10.5 Reedy 540-M4 Brushless	24	78	8.45:1
9.5 Reedy 540-M4 Brushless	23	78	8.82:1
8.5 Reedy 540-M4 Brushless	22	78	9.22:1
7.5 Reedy 540-M4 Brushless	21	78	9.65:1
6.5 Reedy 540-M4 Brushless	20	78	10.14:1

\*75T spur gear (#92294) not included

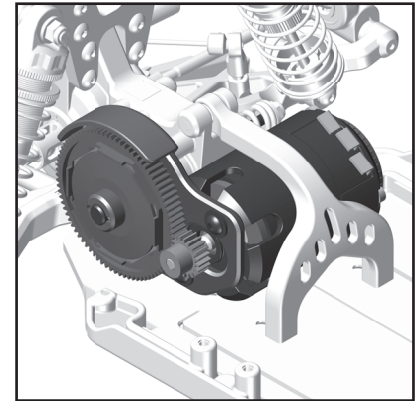

### Set The Gear Mesh:

You should be able to rock the spur gear back and forth in the teeth of the pinion gear without making the pinion gear move. If the spur gear mesh is tight, then loosen the #31532 screws (p. 19) and move the motor away, then try again. A gear mesh that is too tight or too loose will reduce power and damage the gear teeth.

### Diff Height Adjustment:

The diff height adjustment (p.12) is a good way to tune the car for grip level. On high grip with low ride heights, a higher diff height will be a good option. On lower grip with higher ride heights, a lower diff height will be better.

### Gear Box Type:

Selecting the correct gear box is dependent on the type of track it will be used on. The optional 4-gear standup gear box is for the lowest grip conditions. This gear box moves the weight towards the rear of the car and also uses the rotation of the motor to transfer weight to the rear while on-power. The 3-gear standup gear box also moves the weight towards the rear of the car, but in this configuration, the motor's rotation helps with on-power steering. The laydown gear box is used on high grip conditions when on-power steering and stability are most important. This gear box will change directions the quickest and generate the most steering. Layback is used for most indoor clay track conditions.

### Slipper Clutch:

The assembly instructions give you a base setting for your clutch. Turn the nut on the shaft so that the end of the top shaft is even with the outside of the nut. At the track, tighten or loosen the nut in 1/8 turn increments until you hear a faint slipping sound for 1-2 feet on takeoffs. Another popular way to set the clutch is to hold both rear tires firmly in place and apply short bursts of throttle. If the clutch is properly set, the front tires should lift slightly up off the surface.

### Caster:

Caster describes the angle of the caster block as it leans toward the rear of the vehicle. Positive caster means the kingpin leans rearward at the top. The kit includes three inserts to adjust caster angle at the caster block, 0°, 2.5°, and +5°. The total caster angle is the sum of the kick-up angle and the caster block angle. Standard total caster angle for the B6 is 30°, with 25° kick-up and +5° caster block angle.

For less entry steering and more exit steering, try 0° caster block angle.

### Front Camber:

Camber describes the angle at which the tire and wheel rides when looked at from the front. Negative camber means that the tire leans inward at the top. A good starting camber setting is -1°. Positive camber, where the top of the tire is leaning out, is not recommended. A camber gauge can be used to more accurately set camber.

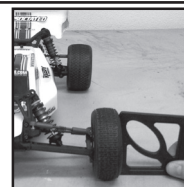

Testing camber with camber gauge

### Rear Camber:

Camber describes the angle at which the tire and wheel rides when looked at from the back. Negative camber means that the tire leans inward at the top. A good starting camber setting is -1°. Adding a small amount of positive camber, where the top of the tire is leaning out, will tend to improve straight-line acceleration on loose tracks. A camber gauge can be used to more accurately set camber.

# FIND IT ON ASSOCIATEDELECTRICS.COM

## CARS & TRUCKS



### Vehicle Spare Parts

GO TO:

[AssociatedElectrics.com](#) →  
[Team Associated tab](#) →  
[Cars & Trucks](#) →  
[Scroll to your vehicle](#) →  
[Parts & Accessories link](#)

## SETUP SHEETS & MANUALS



### Setups and Manuals

GO TO:

[AssociatedElectrics.com](#) →  
[Team Associated tab](#) →  
[Manuals & Setups](#) →  
[Scroll to your vehicle](#)

## A-TEAM APPS



### Tuning Guides & Tips

GO TO:

[AssociatedElectrics.com](#) →  
[Support](#) →  
[A-Team Apps](#)



**Associated Electrics, Inc.**

**21062 Bake Parkway Lake Forest, CA 92630 USA**

**call: (949) 544-7500 - fax: (949) 544-7501**

**Check out the following web sites for all of our kits, current products,  
new releases, setup help, tips, and racing info!**

**[www.AssociatedElectrics.com](http://www.AssociatedElectrics.com)**

**FOLLOW US ON SOCIAL MEDIA**



**TeamAssociated**  
**ReedyPower**  
**ElementRC**

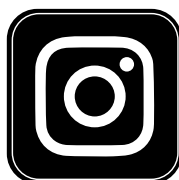

**@TeamAssociatedRC**  
**@ReedyPower**  
**@Element\_RC**

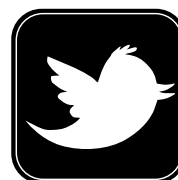

**@Team\_Associated**  
**@ReedyPower**