

Revell

UH-60A Transport Helicopter

04940-0389

©2015 BY REVELL GmbH. A subsidiary of Hobbico, Inc.

PRINTED IN GERMANY



UH-60A Transport Helicopter

Im Januar 1972 schrieb die US-Army einen Wettbewerb an die amerikanische Luftfahrtindustrie aus, um den inzwischen in die Jahre gekommenen Helikopter UH-1 von Bell zu ersetzen. Gestützt auf die Erfahrungen aus dem Vietnam-Krieg, wurden eine höhere Robustheit sowie eine weitaus größere Absturzsicherheit verlangt. Um eine objektive Vergleichbarkeit zu erhalten, gab die Army eine festgelegte Sinkrate, die Absturzhöhe sowie dämpfend wirkende Fahrwerke vor. Sikorsky gewann mit dem Modell YUH-60 die Ausschreibung zu dem UTTAS-Programm (Utility Tactical Transport Aircraft System), auch aufgrund der hohen Überlebensfähigkeit der Piloten, dessen Sitze mit einer speziellen Kevlarpanzerung versehen waren. Der Prototyp mit seinen zwei Wellenturbinen über der Kabine startete am 17. Oktober 1974 zum ersten Mal, ab Oktober 1978 versah der erste seriengefertigte UH-60A Black Hawk (= „Schwarzer Falke“) seinen Dienst.

Der mittelschwere Transporthubschrauber besitzt eine hohe Widerstandsfähigkeit im Gefecht. Nahezu der gesamte Helikopter ist gegen Treffer bis zu einem Kaliber von 762 mm unempfindlich. Die vier Hauptrotorblätter tolerieren sogar einen mäßigen Beschuss mit 23-mm-Kanonen. Ähnlich abgesichert sind auch die bruch- und kugelsicheren Treibstofftanks sowie die Zelle und damit die Besatzung. Dank des speziell konstruierten Flugzellenrahmens aus einer Leichtmetalllegierung bleiben bei einem Aufprall 85 % des Cockpits und der Kabine intakt. Ferner absorbieren die nicht einziehbaren Fahrwerke mittels ihrer Stoßdämpfer beinahe alle Stoßkräfte. Bei Verlust des Hauptgetriebeöldrucks ist die Maschine noch eine Stunde lang flugfähig. Eine Besonderheit stellt der um ca. 20 Grad nach unten geneigte Heckrotor dar. So erzeugt er auch einen gewissen Auftrieb. Bei einer Beschädigung im Flug stellt sich der Rotor automatisch in die Senkrechte und gewährleistet eine sichere Landung.

Die großräumige Kabine bietet 11 vollausgerüsteten Soldaten und drei Mann Besatzung Platz. Acht Truppsitze können leicht entfernt werden, um alternativ Fracht unterzubringen. Abgesehen von einem Lasthaken für das Mitführen von Außenlasten – Traglast 3,6 Tonnen – bietet der Helikopter unter anderem Anlagen zur Abgaskühlung, um die Verwundbarkeit durch hitzeschende Raketen zu verringern, drehbar gelagerte M134-Minikanonen oder 762mm M60-MGs und auf der oberen Biegekante montierte ESSS-Stummelflügel (External Stores Support System) mit vier Stationen für zusätzliche Treibstofftanks oder Bewaffnung wie z.B. Hellfire Panzerabwehrketten.

Der erste Kriseneinsatz der Black Hawks fand 1983 im Rahmen der Operation Urgent Fury bei der Invasion Grenadas statt. Während des Golf Krieges 1991 kamen 300 UH-60 in verschiedenen Varianten für frontnahe Transport-, Versorgungs-, Aufklärungs- sowie Rettungsmissionen zum Einsatz und führten den bis dahin größten Luftangriff in der Geschichte durch.

Technische Daten:

Rumpflänge:	15,26 m
Gesamtlänge:	19,76 m
Höhe:	5,13 m
Leergewicht:	5,1 t
Startgewicht max.:	9,2 t
Triebwerk:	General Electric T700-GE-700
Startleistung:	2 x 1.210 kW
Geschwindigkeit max.:	257 km/h
Reichweite (vollbetankt):	592 km

UH-60A Transport Helicopter

In January 1972 the US Army invited the American aviation industry to tender for a helicopter to replace the now ageing Bell UH-1. Based on the experience gained in the Vietnam War, the new helicopter should be more robust and demonstrate a much greater level of safety and crash survivability. In order to obtain an objective comparison the Army declared a fixed rate of descent, the crash height as well as the damping effect of the undercarriage. Sikorsky won the tender to the UTTAS (Utility Tactical Transport Aircraft System) program with their model YUH-60 also due in part to the high survivability level of the pilot whose seats were surrounded with special Kevlar armour. The prototype with its two turbo-shaft engines above the cabin took off for the first time on 17 October 1974. The first UH-60A Black Hawk's produced in series entered service from October 1978 onwards.

This medium lift helicopter has a high level of battle-worthiness. Almost the entire helicopter is able to absorb small arms fire up to 762 mm calibre without catastrophic failure. The four main rotor blades can even tolerate moderate fire from 23-mm cannon. Similarly protected are also the crash and bulletproof fuel tanks as well as the fuselage and therefore the crew. Thanks to the specially constructed fuselage framework made of a light metal alloy, 85% of the cockpit and the cabin remain intact during a crash. Furthermore, the shock absorbers on the non-retractable landing gear absorb almost all impact forces. With a loss of main gearbox oil pressure, the helicopter is still able to continue flight for one hour. A special feature is the tail rotor which is inclined downwards by about 20 degrees. It therefore also produces a certain amount of lift. In case it is damaged in flight, the rotor automatically returns to the vertical position to ensure a safe landing.

The spacious cabin offers places for 11 fully equipped troops and three crew members. Eight troop seats can be easily removed to alternatively accommodate more cargo. Apart from a hook for lifting external loads – carrying capacity 3.6 tons - the helicopter also has exhaust gas diffusers to reduce its vulnerability to heat-seeking missiles, swivel-mounted M134 mini-guns or 762mm M60 machine guns, and on the shoulder mounted stub wings an ESSS (External Stores Support System) with four stations for additional fuel tanks or weapons such as Hellfire anti-tank missiles.

The Black Hawk's first missions during a crisis took place in 1983 as part of Operation Urgent Fury and the invasion of Grenada. During the Gulf War 1991 300 UH-60 in different versions were deployed close to the forward edge of the battle area on transport, resupply, reconnaissance and rescue missions and led the largest ever air attack in history at that time.

Technical Data:

Length of Fuselage:	15.26 m (50ft 0ins)
Length Overall:	19.76 m (64ft 10ins)
Height:	5.13 m (16ft 10ins)
Empty Weight:	5.1 t
Max. Take-off Weight:	9.2 t
Engines:	General Electric T700-GE-700
Take-off Power:	2 x 1.210 kW
Maximum Speed:	257 km/h (161 mph)
Range:	592 km (370 miles)

Benötigte Farben / Used Colors

Benötigte Farben Required colours	Peintures nécessaires Benötigte kleuren	Pinturas necesarias Tintas necesarias	Colori necessari Använd farger	Tarvitavat värit Du trenger følgende farger	Nødvendige farger Необходимые краски	Poltzobne kolory Απαιτούμενα χρώματα	Gerekli renkler Potrebne bary	Szükséges színek. Potrebne barve
A grau, matt 57 gris, matt gris, mat gris, mate cinzento, fosco grigio, opaco grå, matt hamma, himmeä grå, mat grå, matt серый, матовый szary, matowy γκρι, ματ gri, mat šedá, matná szürke, matt siva, mat	B Dunkelgrün, matt 68 Dark green, matt Vert foncé, mat Verde escuro, mate Verde escuro, mate Verde escuro, opaco Mörkgrön, matt Turmanvihreä, matta Mörkgrön, mat Mörkgrön, matt Тёмно-зелёный, матовый Ciemnozielony, matowy Πράσινο σκούρο, ματ Koyu yeşil, mat Sötétzöld, matt Tmavozelená, matná Temozeleena, brez leska	C beige, seidenmatt 314 beige, silky-matt beige, soiee mat beige, zijemat beige, mate seda beige, fosco sedoso beige, opaco seta beige, seidenmatt beige, silkihimmä beige, silkenmat beige, silkenmat бежовый, шелковисто-матовый beżowy, jadalniczo-matowy µετς, μεταξούτο µατ bej, ipek mat bežová, hedvábně matná bézs, selyemmatt slonovca kost, sivla mat	D anthrazit, matt 9 antracite grey, matt anthracite, mat anthracit, mat antracita, mate antracite, fosco antracite, opaco antracit, mat antracit, himmeä koksgrå, mat antracit, mat antracit, matt антрацит, матовый antracyt, matowy ανθρακί, ματ antracit, mat antracit, matná antracit, matt tanno siva, mat	E feuerrot, glänzend 31 fiery red, gloss rouge feu, brillant rood held, glanzend rjo huojo, briljante vermelho vivo, brilhante rosso fuoco, lucente eldró, blank lipulaivainen, kiiltävä ildrot, skinnende ildrot, blank огне-красный, блестящий szermwony ognisty, błyszczący κόκκινο φωτεινό, γυαλιστερό ateş kırmızı, parlak ohrniv červená, lesklá tűzpiros, fényes ogeyj rdeča, bleskajoča	F silber, metallic 90 silver, metallic argent, métallique zilver, metallic plata, metalizado prata, metalico argento, metallic silver, metallic hopas, metallikilt silv, metallik silv, metallic серебряный, металлический złoty, metaliczny χρυσόφορος, μεταλλικό gümüş, metallic stříbrná, metaliz ezüst, metallik srebna, metallic	G gold, metallic 94 gold, metallic or, métallique goud, metallic oro, metalizado ouro, metalico oro, metalico gold, metallic kulta, metallikilt gold, metallic золотой, металлический złoty, metaliczny χρυσόφορος, μεταλλικό altın, metallic zlata, metaliza arany, metallik zlata, metallic	H eisen, metallic 91 steel, metallic coloris fer, métallique ijzerkleurig, metallic ferruso, metalizado ferro, metalico ferro, metallic jämfärg, metallic teräksenvännen, metallikilt jern, metallic jern, metallic stalový, metalický železo, metaliczny σίδηρου, μεταλλικό demir, metallic železná, metaliza vas, metallik železna, metallic	

I Hellgrau, matt 76 Light grey, matt Gris clar, mat Lichtgrå, mat Gris claro, matt Cinzentissimo, mat Grisjo chiaro, opaco Ljagrå, matt Vaaleanharmaa, matta Lysegrå, mat Lysegrå, matt Светло-серый, матовый Jasnoszary, matowy Κρι ανοιχτό, ματ Agi, gi, mat Viljasoszürke, matt Svjetlo šediva, matná Svetlosivaa, brez leska	J ocker, matt 88 ochre brown, matt ocre, mat oker, mat ocre, mate ocre, fosco ocre, opaco ockra, matt okra (keltamulta), himmeä okker, mat oker, matt ockra, matowy oczna, matowy όχρο, ματ Koyu karamüsi, mat okrové žlutá, matná okker, matt oker, mat	K schwarz, matt 8 black, matt noir, mat zwart, mat negro, mate preto, fosco nero, opaco svart, matt musta, himmeä sort, mat sort, matt czarny, matowy czarny, matowy μαύρο, ματ siyah, mat černá, matná fekete, matt črna, mat	L khaki/braun, matt 86 olive brown, matt brun khaki, mat khakibraun, mat caqui, mat castanho caqui, fosco marone cachi, opaco kaki-brun, mat khakioluska, himmeä khakibrun, mat khakibrun, mat кхакисевый "лак", матовый brązowy khaki, matowy koge-çaki, mat hiváki renki, mat hnádá khaki, matná kekibarna, matt kaki rjava, mat	M nato-oliv, matt 46 Nato-olive, matt olive O.T.A.N., mat Nab-oliv, mat scutellato Nato, mate olive nato, fosco olive nato, opaco Nato-oliv, matt nato olivi, himmeä Nato-oliv, mat NATO-oliven, matt оливковый "НАТО", матовый olivk. NATO, "MATOY" çoki tou NATO, mat nato yeşil, mat olivová NATO, matná Nato-oliv, matt NATO oliva, mat
---	---	---	---	--

Beiliegenden Sicherheitstext beachten / Please note the enclosed safety advice

D: Beiliegenden Sicherheitstext beachten und nachschlagbereit halten.

GB: Please note the enclosed safety advice and keep safe for later reference.

F: Respecter les consignes de sécurité ci-jointes et les conserver à portée de main.

NL: Houdt u aan de bijgaande veiligheidsinstructies en hou deze steeds bij de hand.

E: Observar y siempre tener a disposición este texto de seguridad adjunto.

IT: Seguire le avvertenze di sicurezza allegate e tenerle a portata di mano.

P: Ter em atenção o texto de segurança anexo e guardá-lo para consulta.

S: Beakta bilagad säkerhetstext och håll den i beredskap.

FIN: Huomio! Ja säilytä ohjeiset varoitukset.

Dieser Bausatz wurde in mehreren Qualitäts- und Gewichtskontrollen auf Vollständigkeit überprüft. Reklamationen können nur bearbeitet werden, wenn die **Bauanleitung**, das aus der Kartonage herausgeschnittene **EAN-Strichcode-Feld** und der **Kassenbon** eingeschickt werden. Bitte haben Sie Verständnis dafür, dass wir nur Gewährleistung bei aktuellen Artikeln übernehmen können, die im Zeitraum der letzten 24 Monate erworben worden sind. **Unfrei eingesandene Reklamationendungen werden von uns nicht angenommen!** Einzelteile für Umbauten können gegen Vorkasse erworben werden". Unsere Adresse: Revell GmbH, Abteilung X, Henschelstr. 20-30, 32257 Bünde. Dieser Direktservice gilt für die Länder: Deutschland, Benelux, Österreich, Frankreich, Großbritannien. Reklamationen aus den übrigen Ländern werden über die jeweiligen Distributoren abgewickelt. Bitte kontaktieren Sie Ihren Händler.

This Model Kit has been subject to extensive quality and weight checks during the manufacturing process to ensure it leaves our warehouse in perfect condition. We are only able to process applications for missing parts if the following procedure is followed. In all cases the following will be required before we are able to process any request: Original receipt (proof of purchase) original instruction sheets (will be returned) and the bar code cut out of the box. We may not be able to process requests for products that have been discontinued for more than 24 months. Products that are returned directly to us without prior authorisation by a company representative will not be accepted and returned to sender. Replacement parts for conversion or spares will continue to be available however they will incur a handling charge. Please write to: Department X Revell GmbH, Henschelstr. 20-30, 32257 Bünde.

This direct Service is only available in the following markets: Germany, Benelux, Austria, France & Great Britain, Revell GmbH, Unit 10, Old Airfield Industrial Estate, Cheddington Lane, Tring, Herts, HP23 4QR, Great Britain.

For all other markets contact your local dealer or distributor directly.

DK: Overhold vedlagte sikkerhedsanvisninger og hav dem liggende i nærheden.

N: Ha alltid vedlagt sikkerhetstext klar til bruk.

RUS: Соблюдать технику безопасности, сохранять инструкцию для дальнейших обращений

PL: Stosować się do załączonej karty bezpieczeństwa i mieć ją stale do wglądu.

GR: Προσέξτε τις συνημμένες υποδείξεις ασφαλείας και φυλάξτε τις έτσι ώστε να τις έχετε πάντα σε διάθεση σί.

TR: Ekteki güvenlik talimatlarını dikkate alıp, bakabilmeniz için kendile muafaza ediniz.

CZ: Dbejte na přiložený bezpečnostní text a mějte jej připravený na dosah.

H: A melkelt biztonsági szöveget vegye figyelembe és tartsa fellepozásra készen!

SL: Priložena varnostna navodila izvajajte in jih hranite na vsem dostopnem mestu.

Afin de vous donner entière satisfaction et pour nous assurer que tous les éléments nécessaires au montage de votre maquette sont présents dans la boîte, cet article a subi dans son intégralité divers contrôles qualitatifs ainsi que des contrôle de poids. Si toutefois vous deviez nous faire part de certaines réclamations, nous vous prions de bien vouloir vous adresser à votre revendeur habituel, muni de la notice de montage, du code EAN découpé sur la boîte, ainsi que de votre ticket de caisse. Le SAV ne sera assuré que pour les articles ayant été acquis depuis moins de 24 mois. Les pièces de rechange utilisées pour la transformation de maquettes pourront être obtenues en pré-paiement. Dans le cas où vous n'obtiendriez pas satisfaction, vous pouvez vous adresser directement à notre service SAV à l'adresse suivante: REVELL GmbH, Abteilung X, Henschelstraße 20-30, D-32257 Bünde ou Revell GmbH, 14 B, rue du Chapeau Rouge, F-21000 Dijon, France.

Pour tous les autres marchés, merci de prendre contact avec votre détaillant ou distributeur.

Deze bouwdoos werd verscheidene malen volledig gecontroleerd op kwaliteit en gewicht. Klachten kunnen slechts in behandeling worden genomen indien de bouwhandleiding, de uit de doos geknipte EAN - streepjescode en de kassabon zijn meegezonden. Wij vragen om uw begrip dat wij alleen garantie kunnen geven voor huidige artikelen die binnen een periode van de laatste 24 maanden zijn gekocht. Onvolledig ingezonden klachten kunnen niet in behandeling worden genomen. Onderdelen voor ombouw kunnen tegen vooruitbetaling gekocht worden.

Ans adres is: Revell GmbH, Afdeling X, Henschelstrasse 20-30, 32257 Bünde, Duitsland. Deze directe service geldt alleen voor de volgende landen: Duitsland, Benelux, Oostenrijk, Frankrijk, Groot Brittannië.

Klachten arkonstijg uit overige landen worden via de eventuele locale vertegenwoordigers van Revell afgewikkeld. Wij verzoeken U contact op te nemen met uw winkelier.

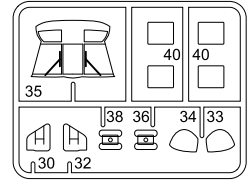
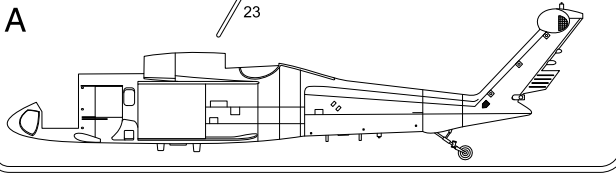
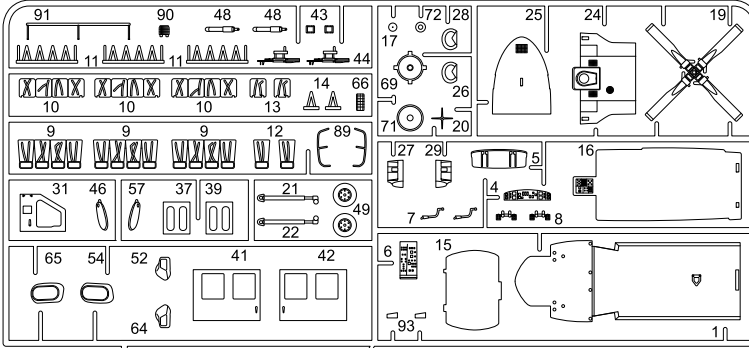

C



Nicht benötigte Teile
 Parts not used
 Pièces non utilisées
 Niet benodigde onderdelen
 Piezas no necesarias
 Peças não utilizadas
 Parti non usate
 Ите неавдица делар
 Tarpeettomat osat
 Ikke nødvendige dele
 Deler som ikke er nødvendige
 Ниспользуемые детали
 Elementy niepotrzebne
 Ил хресољубива сџартијата
 Gereksiz parçalar
 Nepotřebné díly
 fel nem használt alkatrészek
 Nepotrební deli

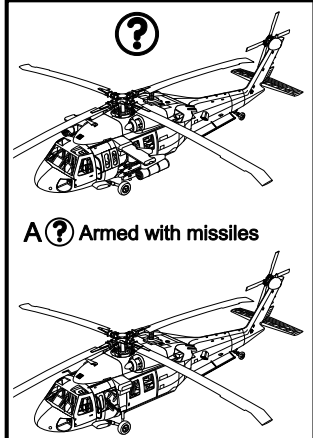
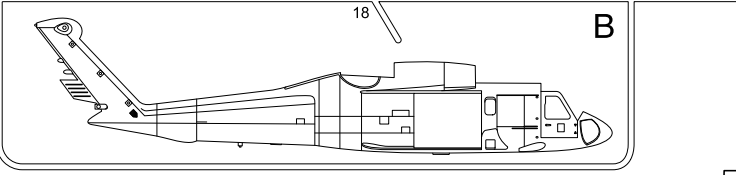
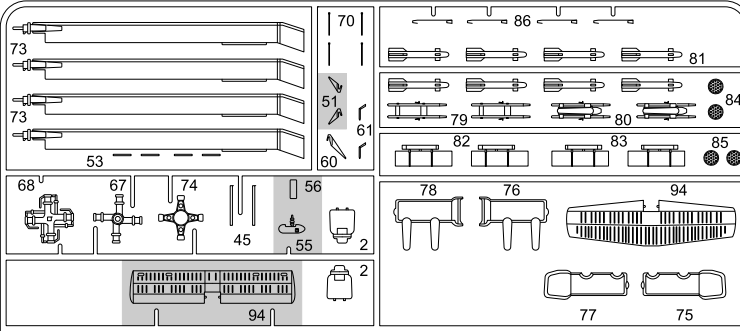

A? Armed with missiles

B? Armed with guns

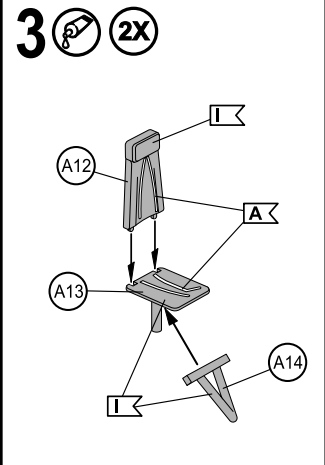
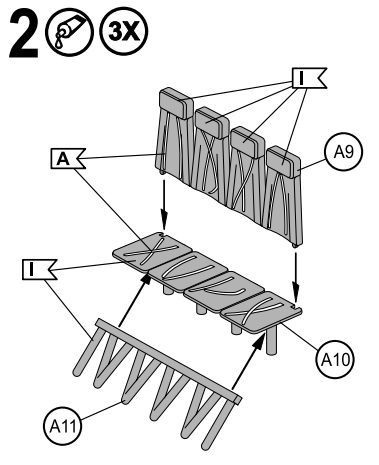
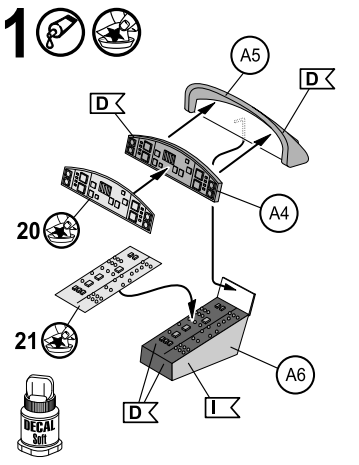

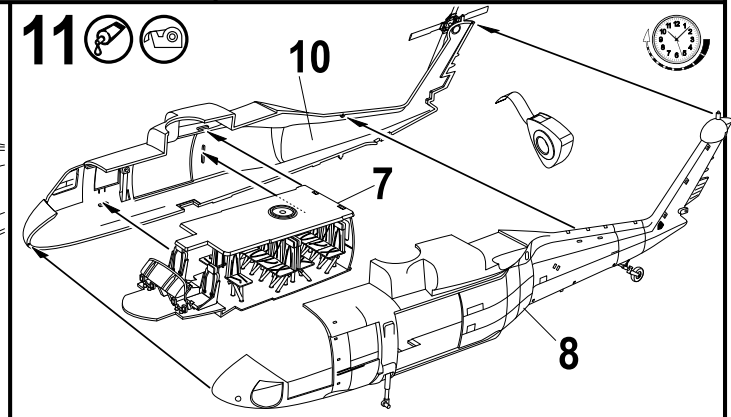
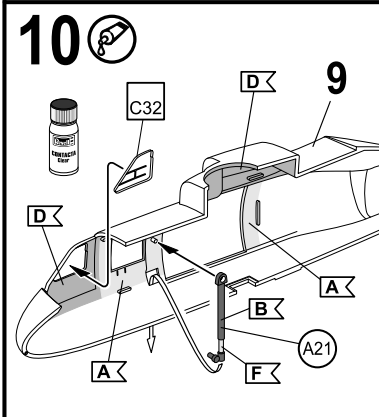
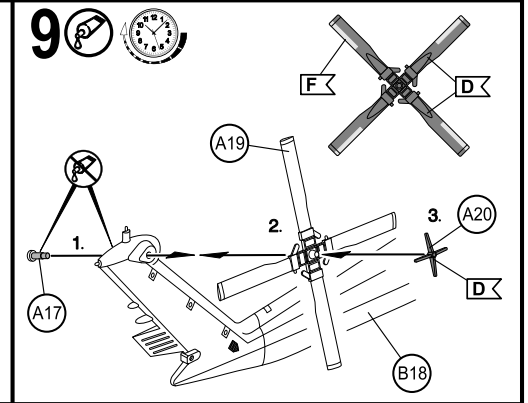
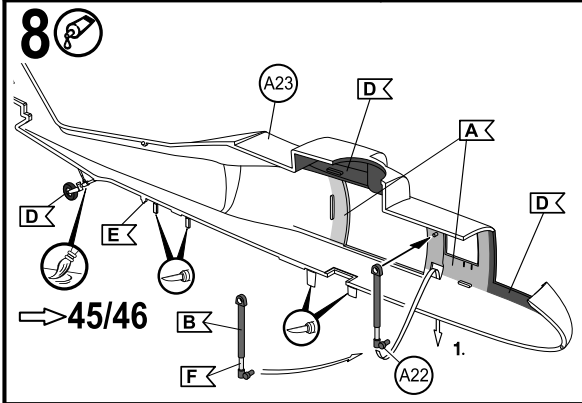
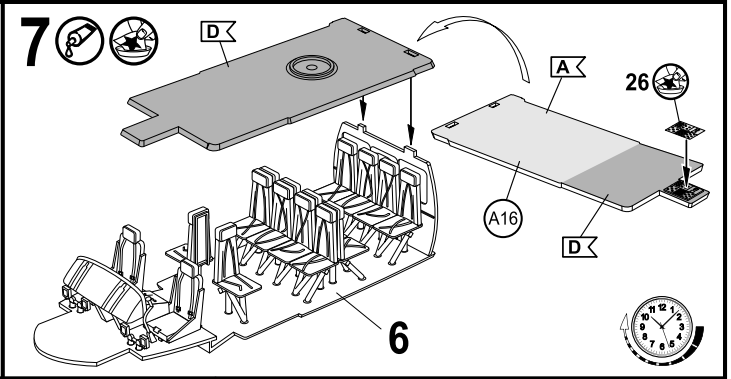
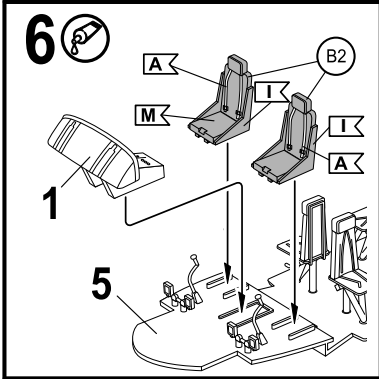
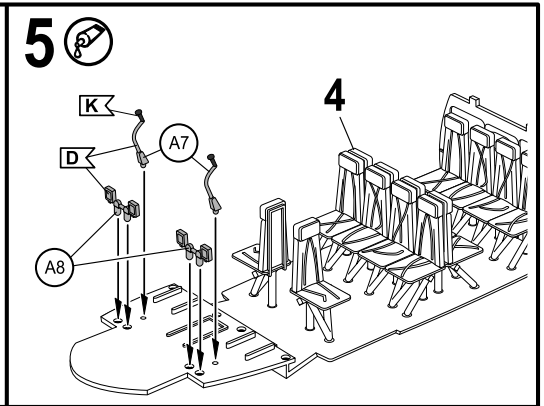
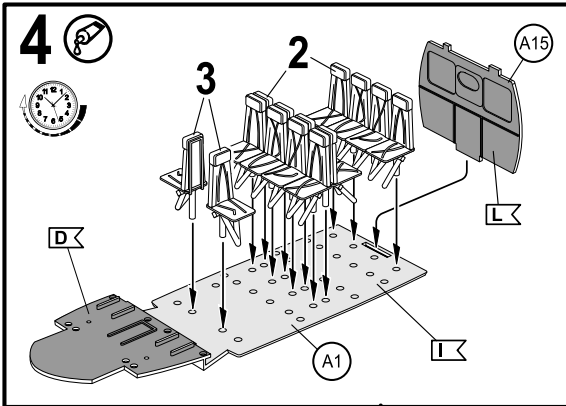

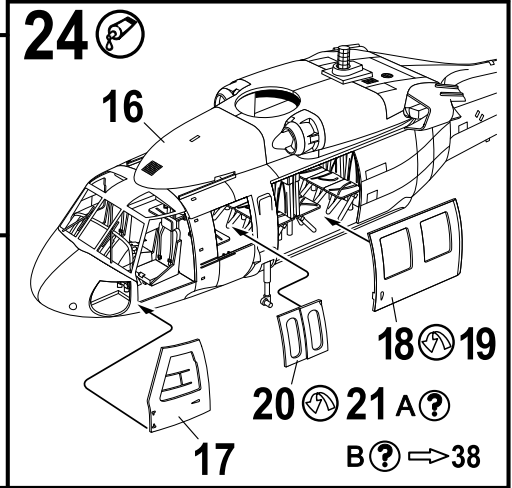
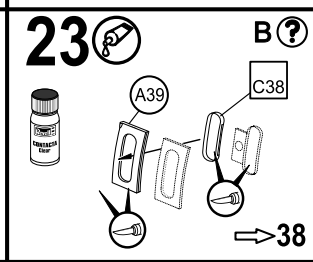
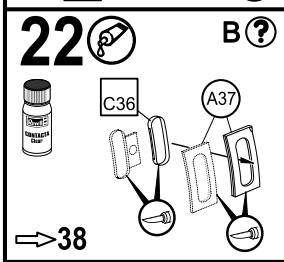
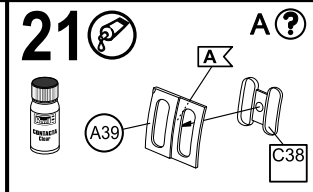
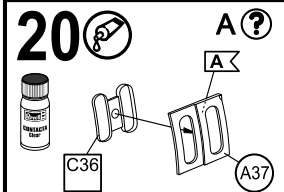
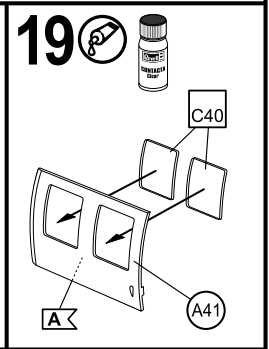
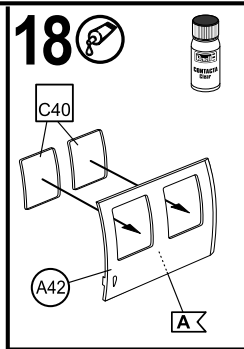
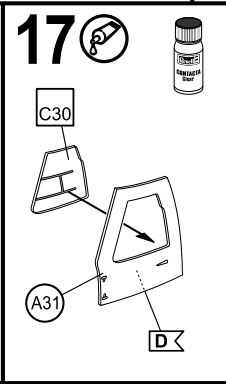
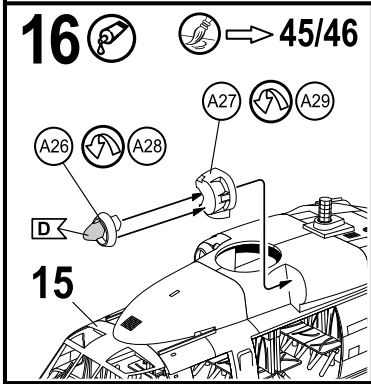
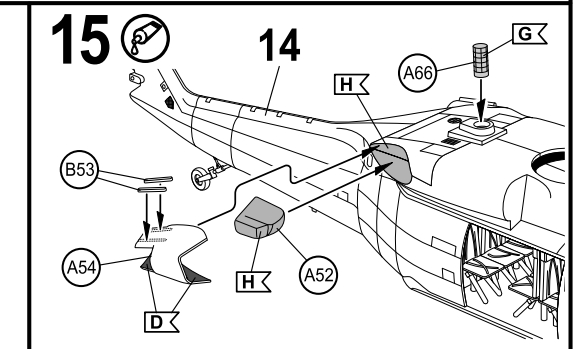
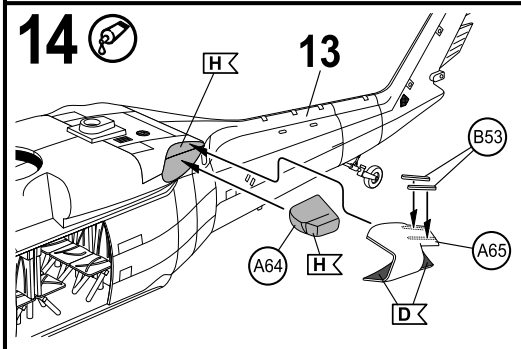
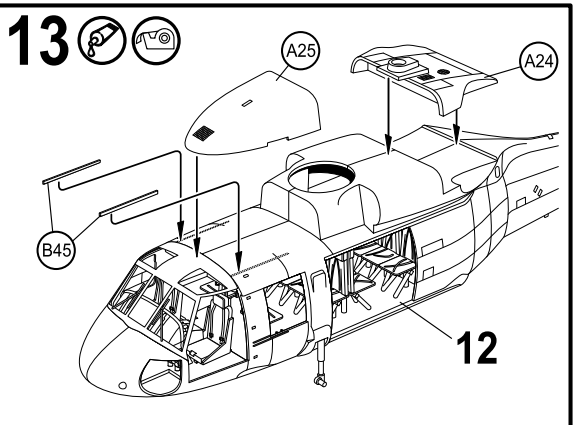
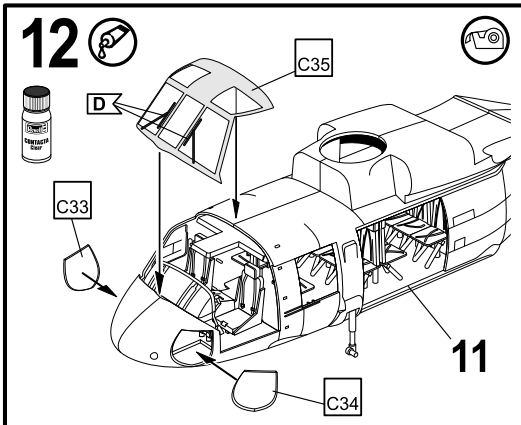

25  

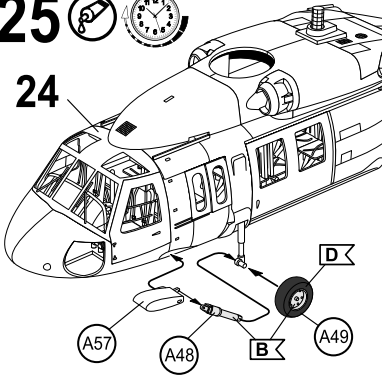

26  

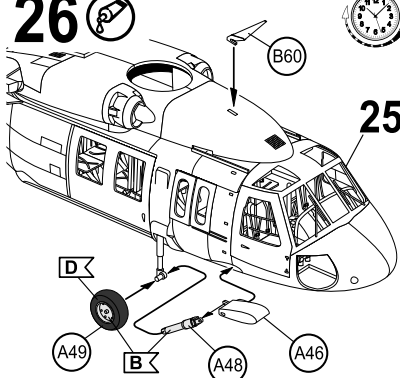

27 

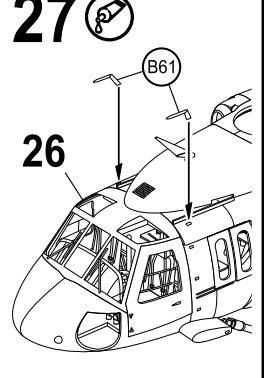

28  

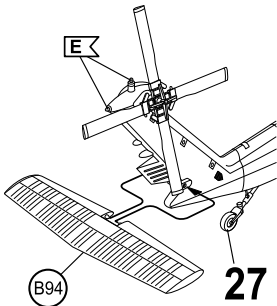

29 

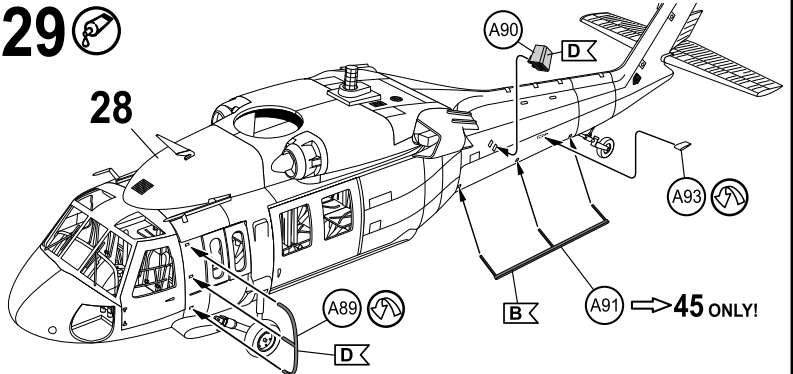

30a  A?
 → 32

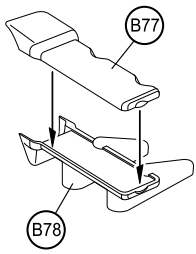

31a  B?
 → 38

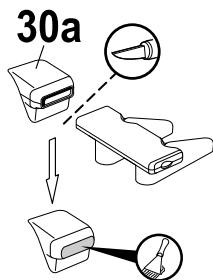

32   A?

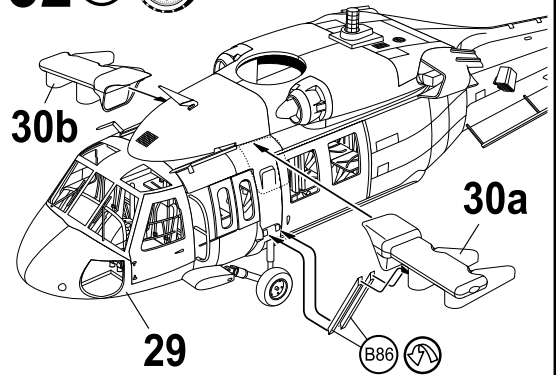

30b  B75 B76

31b  30b

33  A?
 (2X)

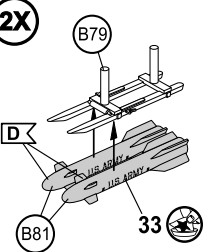

34  A?
 (2X)

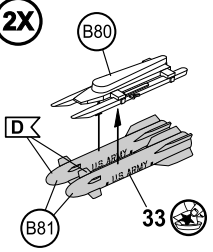

35  A?
 (2X)

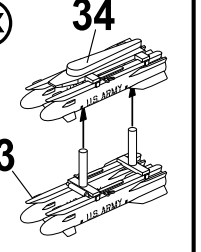

36  (2X) A?
 (2X)

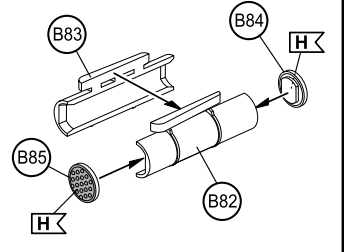

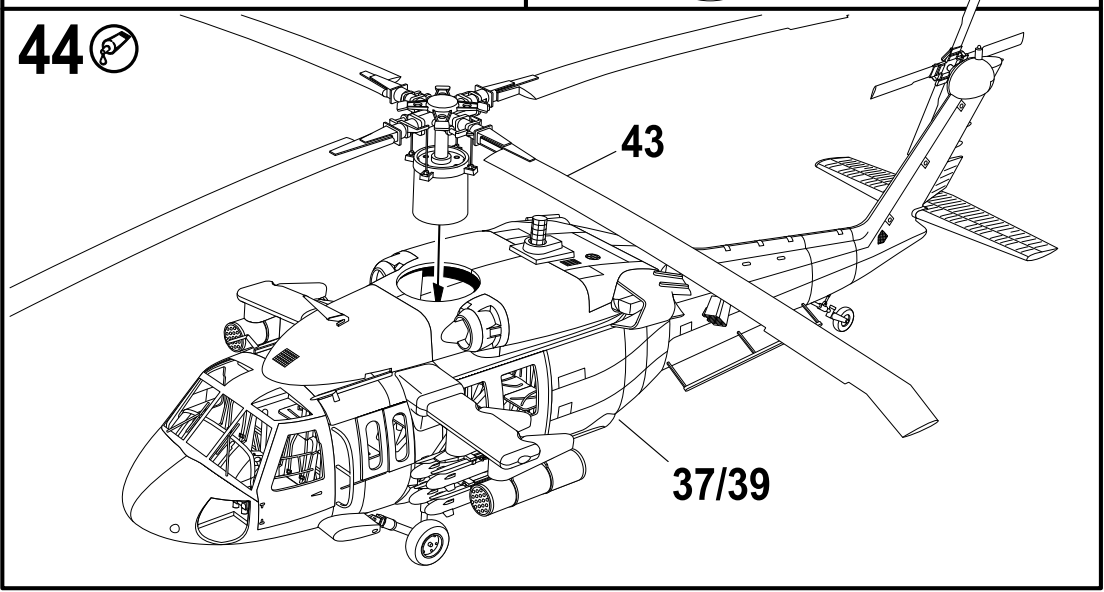
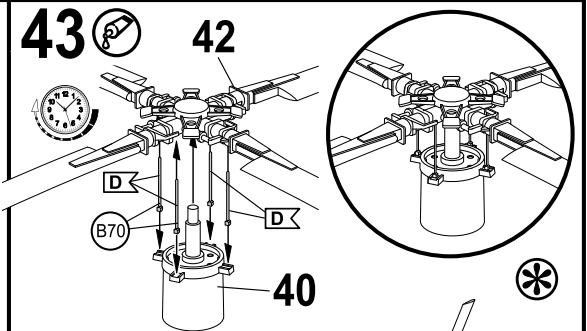
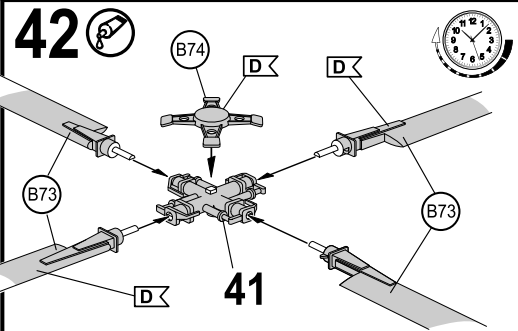
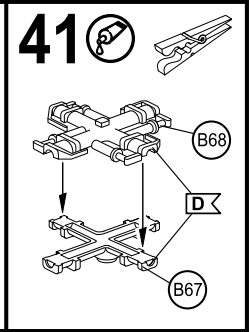
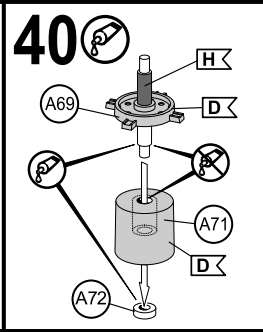
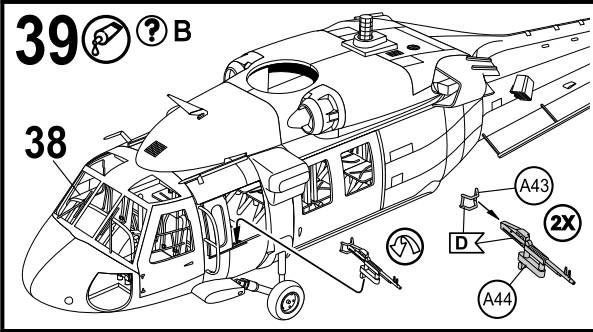
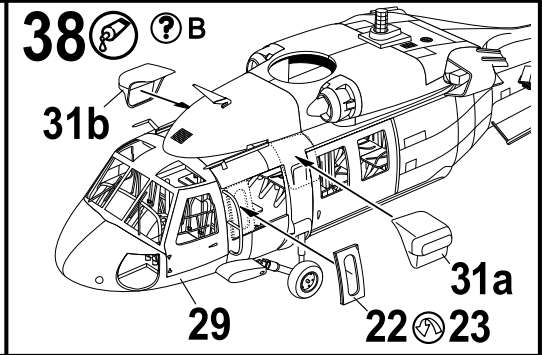
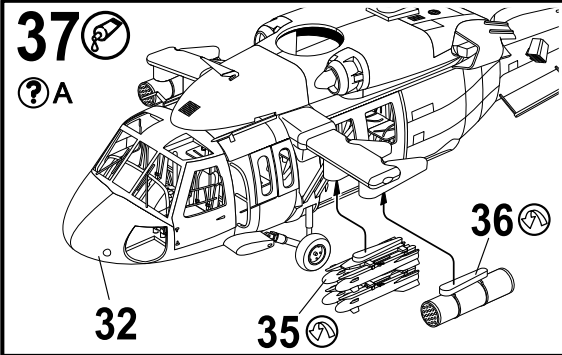

45



UH-60A Black Hawk, U.S Army 10th Mountain Division, Iraq March 2008

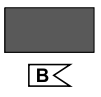
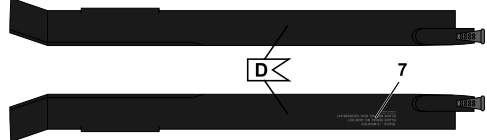
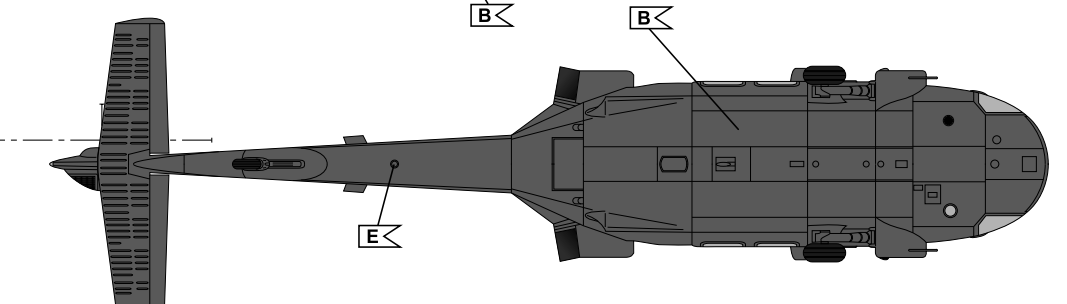
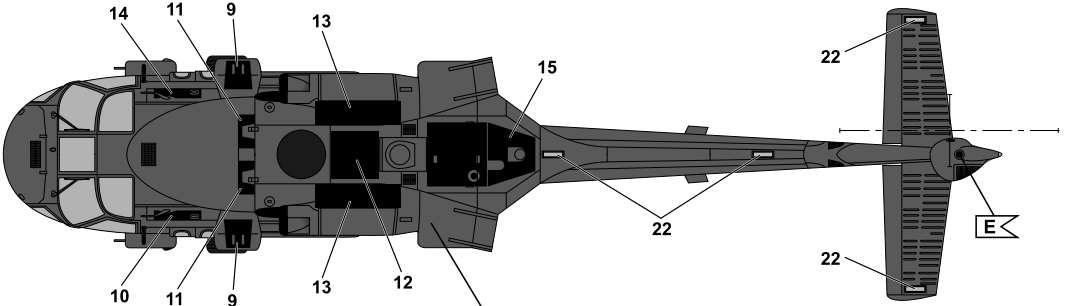
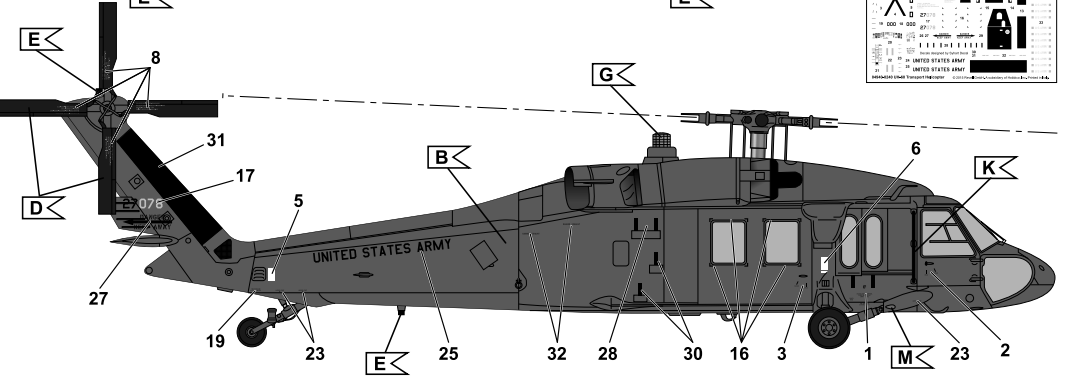
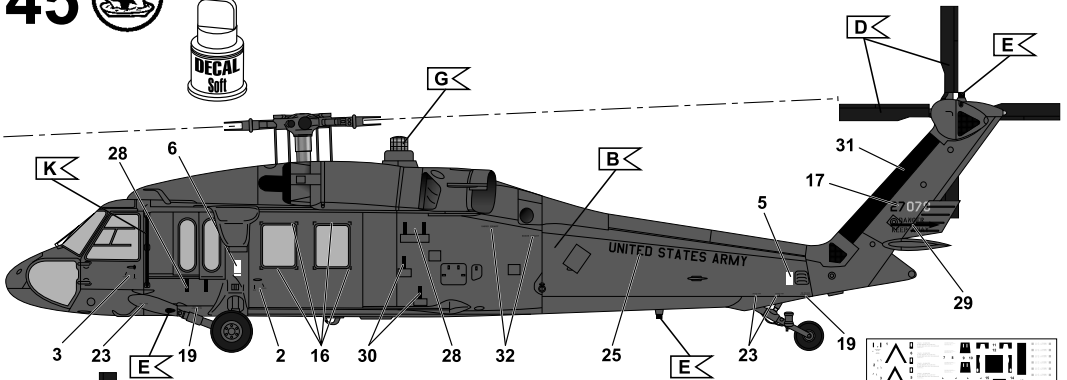

46



UH-60A Black Hawk, U.S Army #87-26000 "Tinnin", Operation "Desert Storm", Iraq 1991

