

Revell Junkers Ju 88A-4 Bomber

04672-0389

©2011 BY REVELL GmbH & Co. KG

PRINTED IN GERMANY



Junkers Ju 88A-4 Bomber

Was die Tornado in unseren Tagen als Mehrzweckkampfflugzeug repräsentiert war in den Zeiten des 2. Weltkrieges die Junkers Ju 88. Sie diente als Sturzkampfbomber und für den Bombeneinsatz aus größeren Höhen, sie war als Jagdflugzeug in der Nachtjagd ebenso erfolgreich wie als Torpedobomber gegen Schiffsziele. Sie konnte als Jäger gegen Panzer eingesetzt werden, sie war Minenleger und Aufklärer. Und in ihren letzten Tagen war sie im Mistelgepann der Bombenträger unter der Me 109 oder Fw 190. Als der 2. Weltkrieg endete stand die Ju 88 noch immer in voller Produktion und bis zu diesem Zeitpunkt waren mehr Ju 88 gebaut worden als alle anderen Bomber der Luftwaffe zusammen genommen - über 15 000 Maschinen.

Geplant und gebaut als Schnellbomber stellte die Ju 88 bereits im März 1938 mit 517 km/h den ersten Weltrekord über die 1000km-Strecke auf -eine Geschwindigkeit die selbst von den damaligen Jagdflugzeugen nicht erreicht wurde. Die erste Serienversion, Ju 88A-1, wurde beim KG 25- später umbenannt in KG 30 "Adlergeschwader" in Dienst gestellt. Zu Beginn des Polenfeldzugs am 1. 9. 1939 hatte diese Einheit aber gerade mal 18 Maschinen, nicht genug um sich an Kriegshandlungen zu beteiligen. Erst im März 1940 war das KG 30 als erster Einsatzverband vollständig mit Ju 88 ausgerüstet. Gleichzeitig begannen bei Junkers die Arbeiten an einer neuen Tragfläche, die neben einer größeren Spannweite auch einen Tragflächen-Randbogen erhielt. Bisher lagen Tragfläche und Querruder der Ju 88A-1 an Ihren Enden völlig offen. Diese neue Tragfläche wurde bereits in die laufende Produktion eingeführt und auch bei den noch vorhandenen Maschinen nachgerüstet. Die erste wirkliche Bewährungsprobe für die Junkers Ju 88 war die "Battle of Britain" die am 8. August 1940 mit dem "Adlertag" begann. Neben dem KG 30 war zu diesem Zeitpunkt nur ein Teil des KG 51 mit Ju 88 ausgerüstet. Die Erfahrungen führten zu einer stärkeren Abwehrbewaffnung. Statt den bisher verwendeten vier MG 15 kam nun das modernere MG 81 - meist in Zwillingen-Lafettierung MG 81Z-zum Einsatz. Gleichzeitig wurde ein stärkere Panzerung zum Schutz der Besatzung eingeführt. Mit der nun greifenden Serienproduktion (2208 Maschinen im Jahr 1940) konnten auch weitere Geschwader vollständig auf Ju 88 umgerüstet werden, darunter auch das Lehrgeschwader 1 (LG 1). Damit wurde die Ju 88 zum Standardbomber der Luftwaffe und trug die Hauptlast der Angriffe gegen Boden- und Schiffsziele auf allen Kriegsschauplätzen von Norwegen bis Afrika. Besondere Erfolge konnte die Ju 88 dabei gegen Schiffsziele erringen, da sie auch als Sturzkampfbomber mit Bombenträgern unter der Tragfläche eingesetzt werden konnte - ein besonderer Vorteil bei Angriffen gegen Punkteziele. Die Serienfertigung der Ju 88 wurde erst gegen Ende 1944 eingestellt.

Technische Daten:

Spannweite	20,08 m
Länge	14,36 m
Höhe	5,07 m
Triebwerke	2x Junkers Jumo 211 J
Leistung	1 410 PS
Leergewicht	8 050 kg
Startgewicht max.	12 460 kg
Höchstgeschwindigkeit	445 km/h
Reisegeschwindigkeit	385 km/h
Landegeschwindigkeit	140 km/h
Reichweite normal	2 520 km
Dienstgipfelhöhe	8 500 m
Bewaffnung	5x MG 81
Bomben/Abwurfaffen	3600 kg
Besatzung	4

Junkers Ju 88A-4 Bomber

Just as the Tornado today represents the Multi Purpose Combat Aircraft, during the Second World War it was the Junkers Ju-88. It served as a conventional high altitude bomber, a dive bomber and was just as effective as a night fighter or even a torpedo bomber engaging surface vessels. It could also be used as a tank killer, mine-layer or even as a reconnaissance aircraft. During its final days it was used as the bomb-carrier in a composite unit under a Me 109 or Fw 190. The Ju 88 was still in full production at the end of the Second World War and up to this point in time more Ju 88's had been built than all the other Luftwaffe bombers put together - over 15000 aircraft.

Designed and built as a fast bomber, the Ju-88 soon set the Worlds first Speed Record over a 1000 km course. In March 1938 it reached a speed of 517km/h (321mph) - a speed that fighter aircraft of the period could not achieve! The first series production model's the Ju 88 A-1, went into service with KG 25 (Fighter Wing 25) which was later renamed KG 30 "Adlergeschwader" (Eagle Wing). On the 1st September 1939 at the start of the Polish Campaign this unit only possessed 18 aircraft, hardly enough to take part in any military action. It was not until March 1940 that KG 30 became the first Operational Unit to be fully equipped with the Ju 88. At the same time Junkers began work on a new wing for the aircraft which in addition to having a larger span also received curved wing-tips. Until then the wing tips and ailerons of the Ju 88A-1 lay completely open. This new wing was immediately incorporated into the production line and fitted retrospectively to aircraft which had the old wing. The "Battle of Britain", which began on 8th August 1940 with "Adlertag" (Day of the Eagle) was the first real test for the Ju 88. As well as KG 30 only part of KG 51 was then equipped with the Ju 88. Combat experience led to the fitting of a stronger defensive armament. Instead of the current four MG 15's the more modern MG 81 was used - mostly fitted in the twin MG 81Z mount. At the same time stronger armour was fitted to protect the crew. With mass production at full pace (In 1940 - 2208 aircraft), more "Wings" could be completely converted to the Ju 88, including Training Wing No1. The Ju 88 was now the Luftwaffe's "Standard Bomber" and carried the brunt of the attacks against enemy ground and maritime targets in all Theatre's of War from Norway to Africa. The Ju 88 was able to notch up exceptional successes against marine shipping. With the addition of bomb-racks under the wings it was able to take on the role of dive-bomber, a distinct advantage when attacking pin-point targets. Mass production of the Ju 88 did not cease until the end of 1944.

Technical Data:

Wingspan:	20.08 m (65ft 10ins)
Length:	14.36 m (47ft 1ins)
Height:	5.07 m (16ft 7ins)
Engines:	2x Junkers Jumo 211 J
Power:	1410 bhp
Empty Weight:	8050 kg (17750lbs)
Max. Take-off Weight:	12460 kg (27474 lbs)
Maximum Speed:	445 km/h (276 mph)
Cruising Speed:	385 km/h (239 mph)
Landing Speed:	140 km/h (75 mph)
Normal Range:	2520 km (1565 miles)
Service Ceiling:	8500 m (27880 ft)
Armament:	5x MG 81
Bombs/Free Fall Weapons:	3600 kg (7938 lbs)
Crew:	4

Form hergestellt und im Eigentum von Revell GmbH & Co. KG. Widerrechtliche Nachahmungen werden gerichtlich verfolgt.

Ce produit est propriété de la société Revell GmbH & Co. KG. Toute utilisation ou duplication frauduleuse fera l'objet de poursuites en justice.

Modelado y en propiedad de Revell GmbH & Co. KG. Imitaciones ilícitas serán perseguidas por la ley.

Forma prodotta dalla Revell GmbH & Co. KG. e di proprietà della stessa impresa, la quale procederà legalmente contro ogni imitazione abusiva.

Modell an Revell GmbH & Co. KG. valmistama ja omlusuvuta. Laittoomaa kopiointiin tulkaa puuttuomaa oikeudellisin toimin.

Design utviklet av og eies av Revell GmbH & Co. KG. Etterligning uten tillatelse blir gjenstand for rettslig forfølgelse.

Produkcja i prawo własności firmy Revell GmbH & Co. KG. Nielegalne podrobienie jest zabronione pod odpowiedzialnością sądową.

Model, Revell GmbH & Co. KG. firmastin mallikyeiti oltinda imal edelmistiri. Konuna oykirii tallitler moikemece takip edellekicit.

A forma előállításja és a tulajdonjog birtokosa a Revell GmbH & Co. KG. A jogellenes utánzatokat és hamisítványokat bírósággal üldözlik.

Mould manufactured by and property of Revell GmbH & Co. KG. Illegal imitations are subject to prosecution.

Vorm vervaardigd door en eigendom van Revell GmbH & Co. KG. Onrechtmatige nabootsingen worden gerechtelijk vervolgd.

Formas produzidas e de propriedade da Revell GmbH & Co. KG. Cópias não autorizadas serão processadas juridicamente como determinado na lei.

Modellen tillverkad av och tillhör Revell GmbH & Co. KG. All kopiering betrivas enligt lagen om upphovsrätt.

Formen er fremstillet af Revell GmbH & Co. KG. som også har ejendomsret. Lovstridige efterligninger søgsges.

Модель изготовлена и принадлежит собственности фирмы Revell GmbH & Co. KG. Противозаконные подделки преследуются иются в судебном порядке.

Η μορφή κατασκευαστηκε και περιηληθε ιδιοκτησια της Revell GmbH & Co. KG. Οι παρωμοεις μιμησεις θα καταδικωνονται δικαστικως.

Vyar byl vytvořen firmou Revell GmbH & Co. KG. a je jejím vlastnictvím. Proti nezákonným napodobením se bude postupovat soudní cestou.

Forma je proizvedena in je vlasnistvo Revell GmbH & Co. KG. Neovlascene kopije bodo pravno kaznjene.

Benötigte Farben/Used Colors

Benötigte Farben Required colours	Peintures nécessaires Benodigde kleuren	Pinturas necesarias Tintas necessárias	Colori necessari Använda färger	Tarvittavat värit Du trenger følgende farger	Nødvendige farger Необходимые краски	Potrzebne kolory Απαιτούμενα χρώματα	Gerekli renkler Potrebne barvy	Szükséges színek Potrebne barve
A Schwarzgrün, matt 40 Black green, matt Vert noir, mat Zwartgroen, mat Negro verdoso, mate Verde-preto, mate Nero verde, opaco Svartgrön, matt Mustanvihreä, matta Sortgrön, mat Sortgrønn, matt Чёрно-зелёный, матовый Czarnozielony, matowy Πράσινο σκούρο, ματ Siyah yeşili, mat Feketeszöld, matt Černozeleá, matná Črnozelená, brez leska	B Dunkelgrün, matt 39 Dark green, matt Vert foncé, mat Donkergroen, mat Verde oscuro, mate Verde-escuro, mate Verde scuro, opaco Mörkgrön, matt Tummanvihreä, matta Markegrön, mat Markgrønn, matt Тёмно-зелёный, матовый Ciemnozielony, matowy Πράσινο σκούρο, ματ Koyu yeşil, mat Sötétzöld, matt Tmavomodrá, matná Temnozelená, brez leska	C Hellblau, matt 49 Light blue, matt Bleu clair, mat Lichtblau, mat Azul claro, mate Azul-claro, mate Blu chiaro, opaco Ljusblå, matt Vaaleansininen, matta Lyseblå, mat Lysblå, matt Светло-синий, матовый Jasnoniebieski, matowy Μπλε ανοιχτό, ματ Açık mavi, mat Világoskék, matt Světle modrá, matná Svetlomodrá, brez leska	D weiß, matt 5 white, matt blanc, mat wit, mat blanco, mate branco, fosco bianco, opaco vit, matt valkoinen, himmeä hvid, matt hvít, matt белый, матовый biały, matowy λευκό, ματ beyaz, mat bílá, matná fehér, matt bela, mat	E helloliv, matt 45 light olive, matt olive clair, mat olijf-licht, mat aceituna, mate oliva claro, fosco oliva chiaro, opaco ljusoliv, matt vaalean olivi, himmeä lysoliv, matt lys oliven, matt светло-оливковый, матовый jasnooliwk., matowy ανοιχτό χράκι, ματ açık zeytuni, mat světloolivová, matná világos oliv, matt svetlo oliva, mat	F staubgrau, matt 77 dust grey, matt gris poussiéré, mat stofgrijs, mat ceniciento, mate oliva claro, fosco grigio sabbia, opaco dammgrå, matt pölynharmaa, himmeä stovgrå, mat stovgrå, matt серый пыльный, матовый szary kurz, matowy χρόμι ακόννης, ματ toz grisi, mat prachově šedá, matná porszürke, matt prah siva, mat	G karminrot, matt 36 carmin red, matt rouge carmin, mat karmijnrood, mat carmin, mate vermelho carmin, fosco rosso carminio, opaco karmínröd, matt karmíninpunainen, himmeä karmínröd, matt karmínröd, matt красный кармин, матовый karmínový, matowy κόκκινο όϊήϊό, ματ lál rengi, mat krbově červená, matná kárminpiros, matt šminka rdeča, mat	H anthrazit, matt 9 anthracite grey, matt anthracite, mat antraciet, mat antracita, mate antracite, fosco antracite, opaco antracit, matt antrasitti, himmeä koksgrå, mat antrasitt, matt антрацит, матовый antracyt, matowy ανθρακί, ματ antrasit, mat antracit, matná antracit, matt tamno siva, mat	

I laubgrün, seidenmatt 364 leaf green, silky-matt vert feuille, satiné mat bladgroen, zijdemat verde follaje, mate seda verde gao, fosco sedoso verde foglia, opaco seta lövggrön, sidenmatt lehdenvihreä, silkinhimmeä lovgrön, silkematt lovgrønn, silkematt лиственно-зелёный, шелк.-матовый zielony lisciasty, jedwabisto-matowy πράσινο φυλλωμάτων, μεταξή, ματ yaprak yeşili, ipek mat zelená jako listi, hedvábné matná lemböld, selyemmatt list zelena, svila mat	J schwarz, seidenmatt 302 black, silky-matt noir, satiné mat zwart, zijdemat negro, mate seda preto, fosco sedoso nero, opaco seta svart, sidenmatt musta, silkinhimmeä sort, silkematt sort, silkematt чёрный, шелковисто-матовый czarny, jedwabisto-matowy μαύρο, μεταξωτό ματ siyah, ipek mat černá, hedvábné matná fekete, selyemmatt črna, svila mat	K aluminium, metallic 99 aluminium, metallic aluminium, métallique aluminium, metallic aluminio, metalizado aluminio, metálico alluminio, metalico aluminium, metallic alumiini, metalliitto aluminium, metallak aluminium, metallic алюминиевый, металл aluminium, metaliczny αλουμίνιου, μεταλλικό aluminium, metallik hliníková, metaliza aluminium, metall aluminium, metallik	L rost, matt 83 rust, matt rouille, mat roest, mat orin, mate ferrugem, fosco color ruggine, opaco rost, matt ruoste, himmeä rust, matt rust, matt ржавчина, матовый rdzawy, matowy χρώμα σκουριάς, ματ pas rengi, mat rezavá, matná rozsdá, matt rjava, mat	M lederbraun, matt 84 leather brown, matt brun cuir, mat lederbruin, mat marrón cuero, mate castanho couro, fosco marrone cuoio, opaco läderbrun, matt nahkanruskea, himmeä läderbrun, mat läderbrun, mat korичневая кожа, матовый brunatny jak skóra, matowy καφέ δερματός, ματ deri kahverengi, mat koženě hnědá, matná b(E)rbara, matt koža rjava, mat	75% N eisen, metallic 91 steel, metallic coloris fer, métallique ijzerkleurig, metallic ferroso, metalizado ferro, metálico ferro, metalico járnfärg, metallic teräksenväri, metalliitto jern, metallak jern, metallic стальной, металл żelazo, metaliczny οιδήρου, μεταλλικό demir, metallik železná, metaliza vas, metall železná, metallik	25% anthrazit, matt 9 anthracite grey, matt anthracite, mat antraciet, mat antracita, mate antracite, fosco antracite, opaco antracit, matt antrasitti, himmeä koksgrå, mat antrasitt, matt антрацит, матовый antracyt, matowy ανθρακί, ματ antrasit, mat antracit, matná antracit, matt tamno siva, mat
--	--	---	---	--	--	---

O gelb, matt 15 yellow, matt jaune, mat geel, mat amarillo, mate amarelo, fosco giallo, opaco gul, matt keltainen, himmeä gul, mat gul, matt желтый, матовый zófty, matowy κίτρινο, ματ sari, mat žlutá, matná sárga, matt rumena, mat	P blau, matt 56 blue, matt bleu, mat blauw, mat azul, mate azul, fosco blu, opaco sininen, himmeä blá, matt blá, matt синий, матовый niebieski, matowy μπλε, ματ mavi, mat modrá, matná kék, matt plava, mat	Q braun, matt 85 brown, matt brun, mat bruin, mat marrón, mate castanho, fosco marrone, opaco brun, matt ruskea, himmeä brun, mat brun, matt коричневый, матовый brązowy, matowy καφέ, ματ kahverengi, mat hnědá, matná barna, matt rjava, mat	90% R weiß, matt 5 white, matt blanc, mat wit, mat blanco, mate branco, fosco bianco, opaco vit, matt valkoinen, himmeä hvid, matt hvít, matt белый, матовый biały, matowy λευκό, ματ beyaz, mat bílá, matná fehér, matt bela, mat	10% blau, matt 56 blue, matt bleu, mat blauw, mat azul, mate azul, fosco blu, opaco sininen, himmeä blá, matt blá, matt синий, матовый niebieski, matowy μπλε, ματ mavi, mat modrá, matná kék, matt plava, mat	S Hellgrau, matt 76 Light grey, matt Gris clair, mat Lichtgrijs, mat Gris claro, mate Cincento-claro, mate Grigio chiaro, opaco Ljusgrå, matt Vaaleanharmaa, matta Lysegrå, mat Lysgrå, matt Светло-серый, матовый Jasnoszary, matowy Γκρι ανοιχτό, ματ Açık gri, mat Világosszürke, matt Světle šedivá, matná Svetlosiva, brez leska	T Afrikabraun, matt 17 Africa brown, matt Brun Afrique, mat Afrikabruin, mat Marrón africano, mate Castanho-africano, mate Bruno africano, opaco Afrikabrun, matt Khakinruskea, matta Afrikabrun, mat Afrika-brun, matt Африкано-коричневый, матовый Braz afrykański, matowy Καφέ Αφρικής, ματ Afrika kahverengisi, mat Afrikabarna, matt Africká hnědá, matná Afríkorjava, brez leska	U hellgrau, seidenmatt 371 light grey, silky-matt gris clair, satiné mat lichtgrijs, zijdemat gris claro, mate seda cincento claro, fosco sedoso grigio chiaro, opaco seta ljusgrå, sidenmatt vaaleanharmaa, silkinhimmeä lysegrå, silkematt lysgrå, silkematt светло-серый, шелковисто-матовый jasnoszary, jedwabisto-matowy ανοιχτό γκρι, μεταξωτό ματ açık gri, ipek mat světleshedá, hedvábné matná világosszürke, selyemmatt svetlo siva, svila mat
---	--	---	---	--	--	---	---

Dieser Bausatz wurde in mehreren Qualitäts- und Gewichtskontrollen auf Vollständigkeit überprüft. Reklamationen können nur bearbeitet werden, wenn die **Bauanleitung**, das aus der Kartongabe herausgeschnittene **EAN-Strichcode-Feld** und der **Kassenbon** eingeschickt werden. Bitte haben Sie Verständnis dafür, dass wir nur Gewährleistung bei aktuellen Artikeln übernehmen können, die im Zeitraum der letzten 24 Monate erworben worden sind. **Unfrei eingesandte Reklamationssendungen werden von uns nicht angenommen!** „Einzelteile für Umbauten können gegen Vorkasse erworben werden“. Unsere Adresse: Revell GmbH & Co. KG, Abteiling X, Henschelstr. 20-30, 32257 Bünde. Dieser Direktservice gilt für die Länder: Deutschland, Benelux, Österreich, Frankreich, Großbritannien. Reklamationen aus den übrigen Ländern werden über die jeweiligen Distributeure abgewickelt. Bitte kontaktieren Sie Ihren Händler.

This Model Kit has been subject to extensive quality and weight checks during the manufacturing process to ensure it leaves our warehouse in perfect condition. We are only able to process applications for missing parts if the following procedure is followed. In all cases the following will be required before we are able to process any request: Original receipt (proof of purchase) original instruction sheets (will be returned) and the bar code cut out of the box. We may not be able to process requests for products that have been discontinued for more than 24 months. Products that are returned directly to us without prior authorisation by a company representative will not be accepted and returned to sender. Replacement parts for conversion or spares will continue to be available however they will incur a handling charge. Please write to: Department X, Revell GmbH & Co. KG, Henschelstr. 20-30, 32257 Bünde. This direct service is only available in the following markets: Germany, Benelux, Austria, France & Great Britain, Revell GmbH & Co. KG, Boston Houso, 64-66 Queensway, Hemel Hempstead, Herts, HP2 5HA, Great Britain. For all other markets please contact your local dealer or distributor directly.

Afin de vous donner entière satisfaction et pour nous assurer que tous les éléments nécessaires au montage de votre maquette sont présents dans la boîte, cet article a subi dans son intégralité divers contrôles qualitatifs ainsi que des contrôles de poids. Si toutefois vous deviez nous faire part de certaines réclamations, nous vous prions de bien vouloir vous adresser à votre revendeur habituel, muni de la notice de montage, du code EAN découpé sur la boîte, ainsi que de votre ticket de caisse. Le SAV ne sera assuré que pour les articles ayant été acquis depuis moins de 24 mois. Les pièces de rechange utilisées pour la transformation de maquettes pourront être obtenues en pré-paiement. Dans le cas où vous n'obtiendriez pas satisfaction, vous pouvez vous adresser directement à notre service SAV à l'adresse suivante: REVELL GmbH & Co. KG, Abteilung X, Henschelstraße 20-30, D-32257 Bünde ou Revell GmbH & Co. KG, 14 B, rue du Chapeau Rouge, F-21000 Dijon, France. Pour tous les autres marchés, merci de prendre contact avec votre détaillant ou distributeur.

Deze bouwdoos werd verscheidene malen volledig gecontroleerd op kwaliteit en gewicht. Klachten kunnen slechts in behandeling worden genomen indien de bouwhandleiding, de uit de doos geknipte EAN - streepjescode en de kassabon zijn meegezonden. Wij vragen om uw begrip dat wij alleen garantie kunnen geven voor huidige artikelen die binnen een periode van de laatste 24 maanden zijn gekocht. Onvolledig ingezonden klachten kunnen niet in behandeling worden genomen. Onderdelen voor ombouw kunnen tegen vooruitbetaling gekocht worden. Ons adres is: Revell GmbH & Co. KG, Afdeling X, Henschelstrasse 20-30, 32257 Bünde, Duitsland. Deze directe service geldt alleen voor de volgende landen: Duitsland, Benelux, Oostenrijk, Frankrijk, Groot-Brittannië. Klachten afkomstig uit overige landen worden via de eventuele lokale vertegenwoordigers van Revell afgewikkeld. Wij verzoeken U contact op te nemen met uw winkelier.

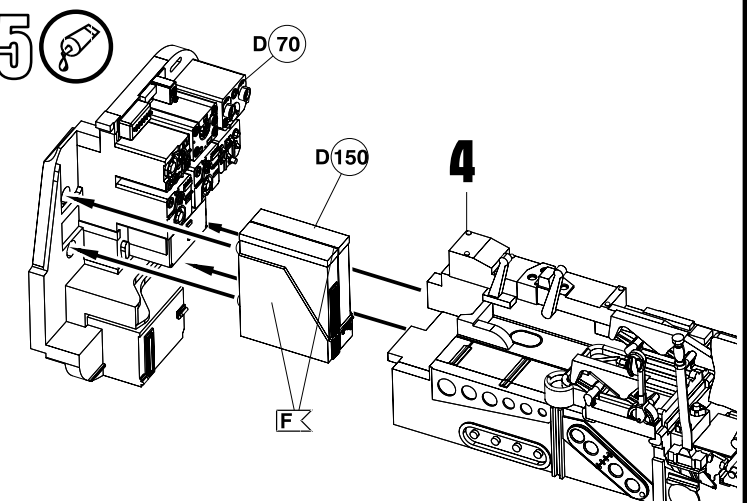
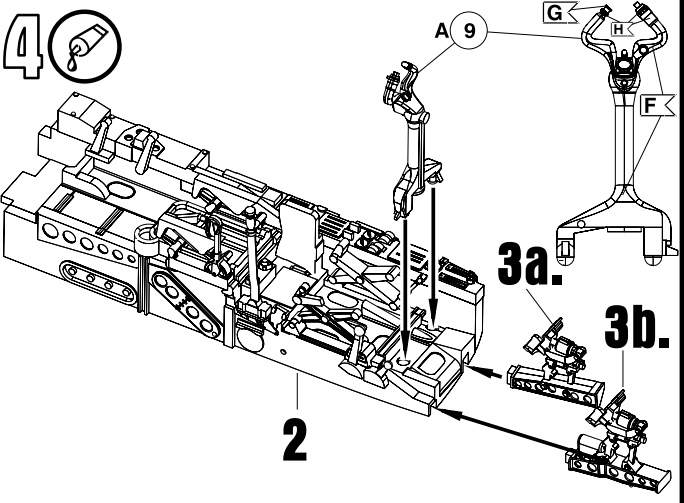
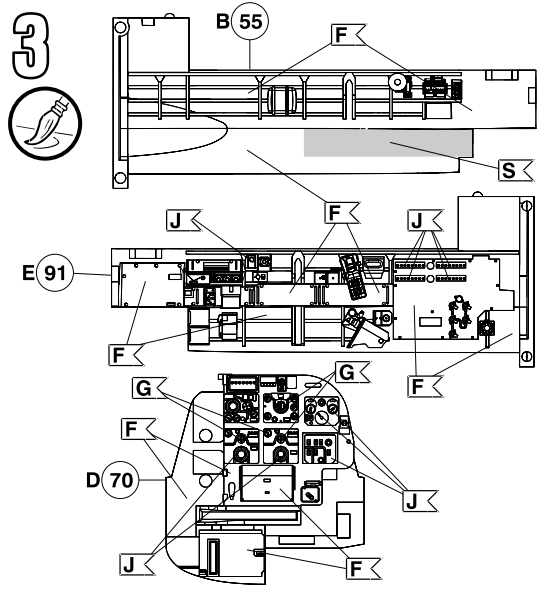
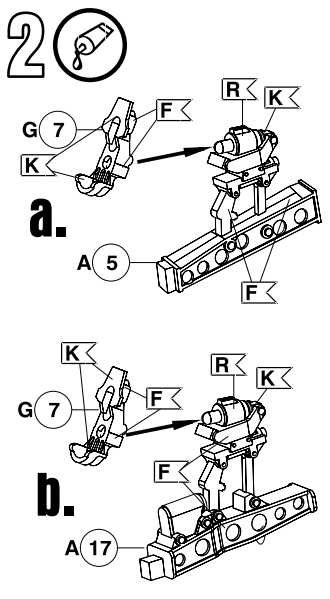
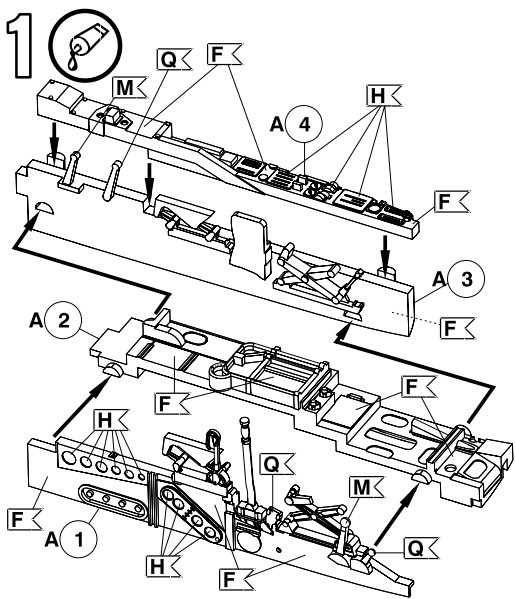
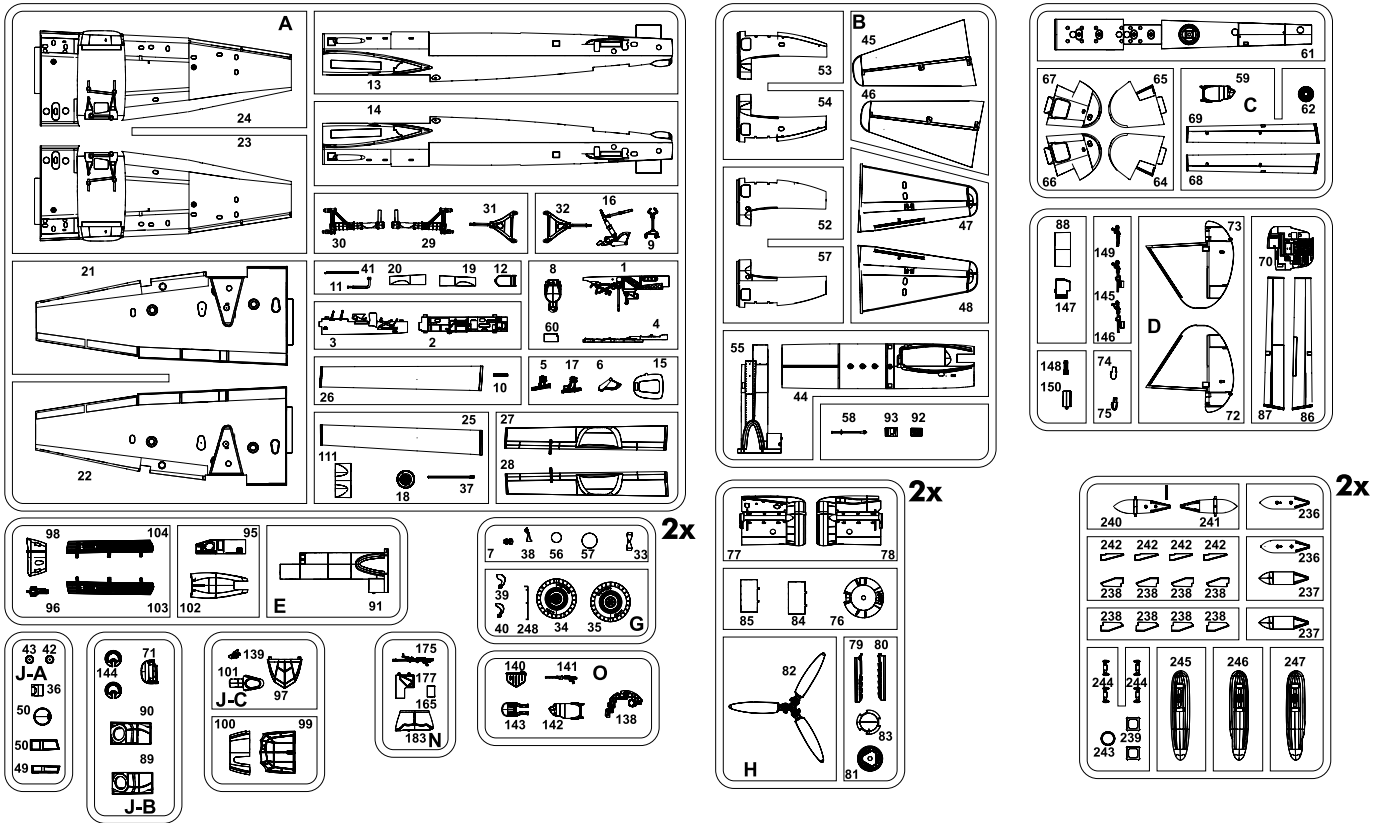

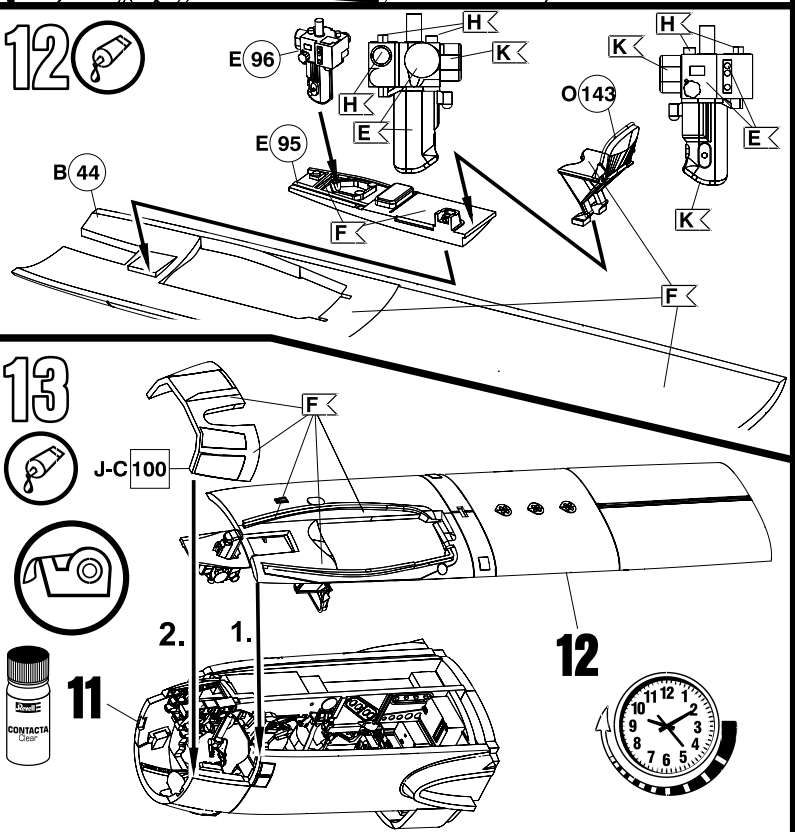
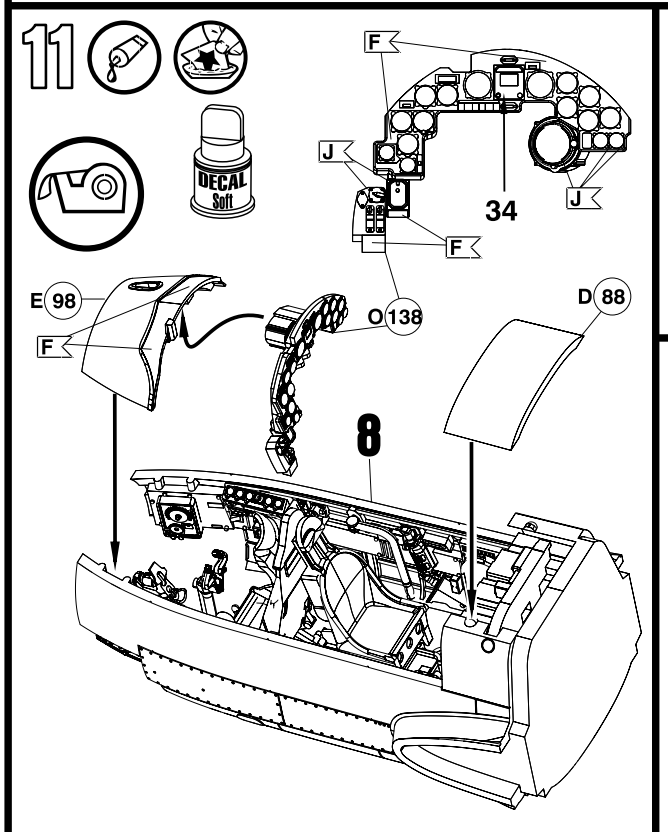
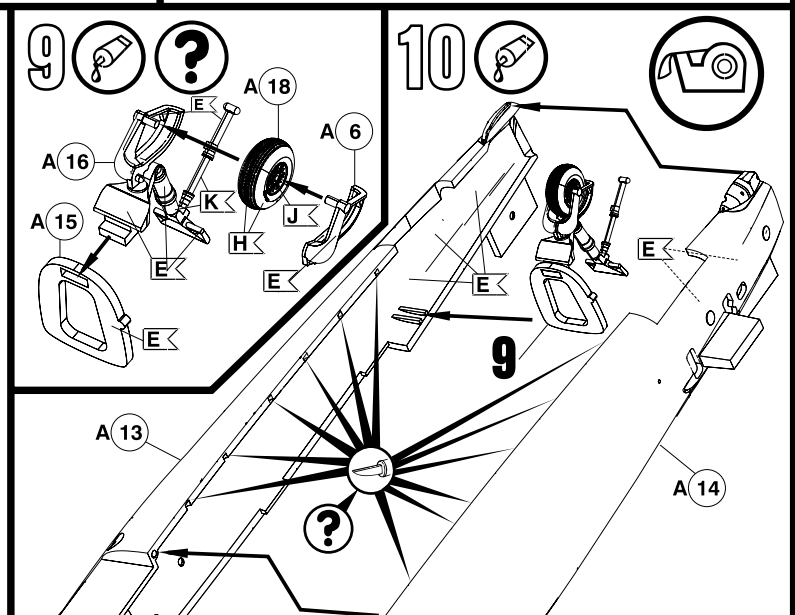
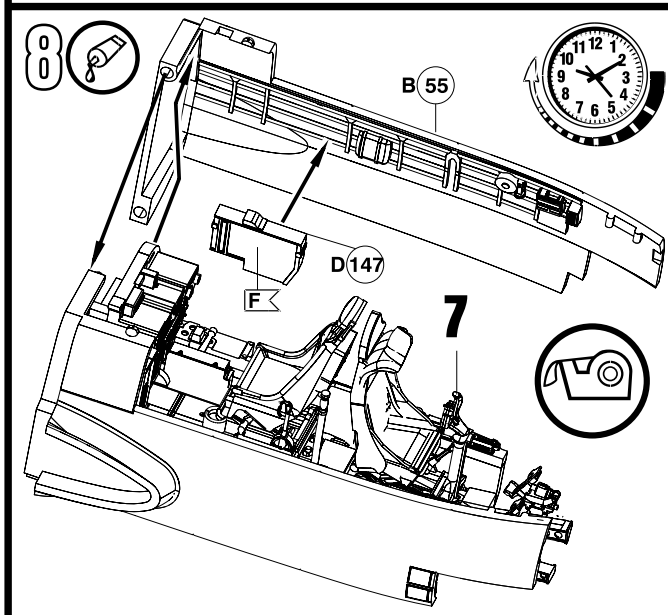
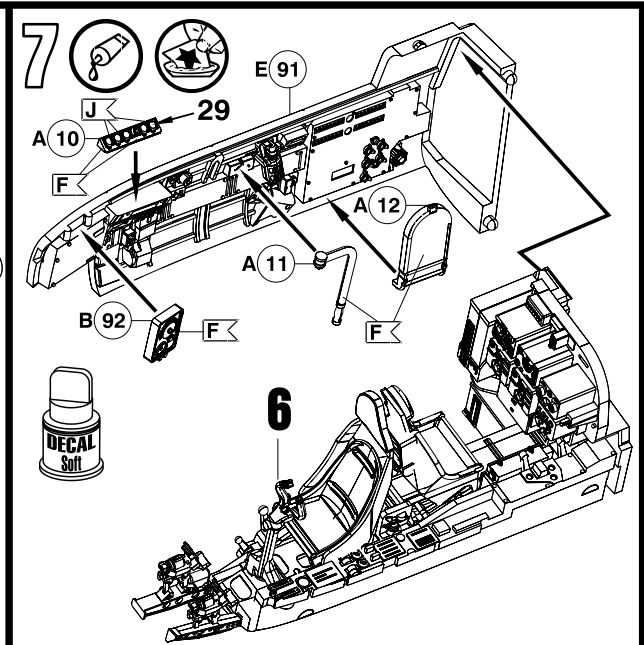
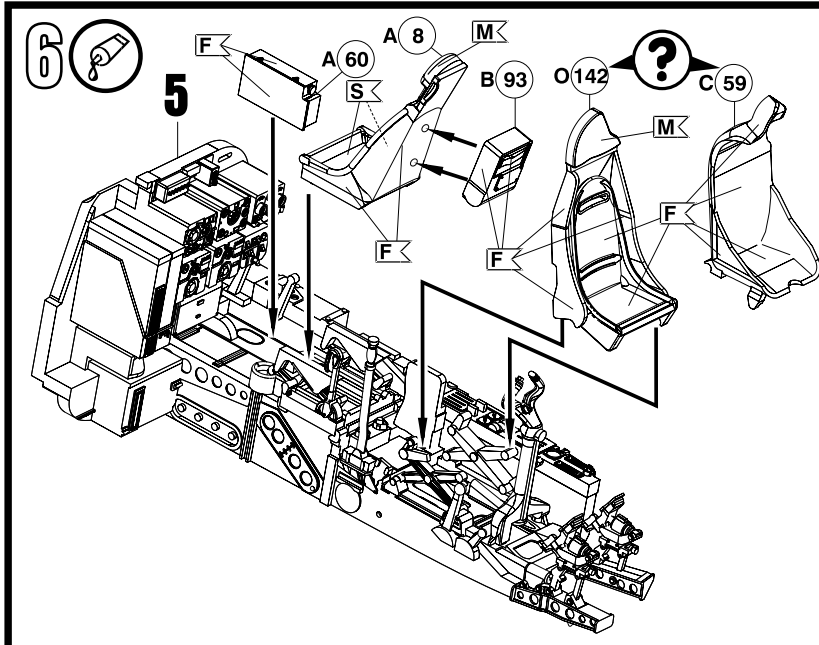

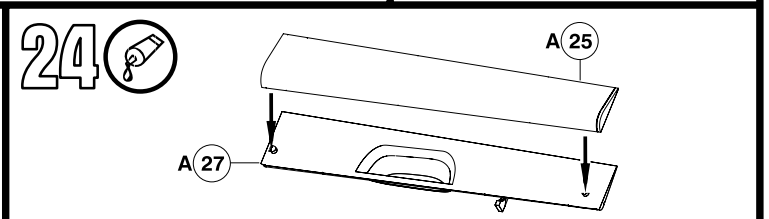
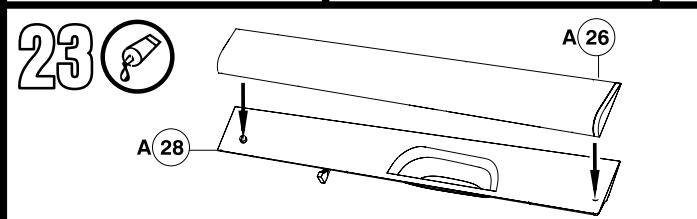
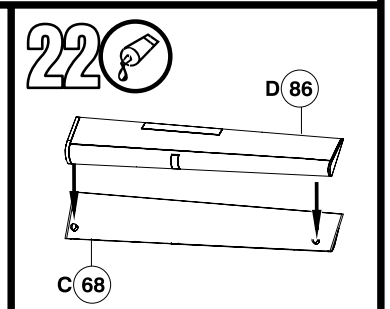
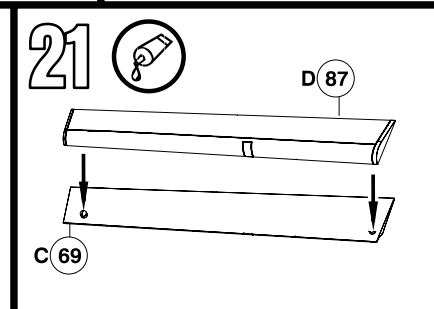
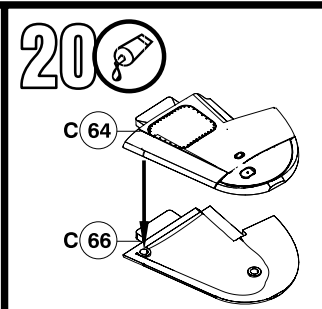
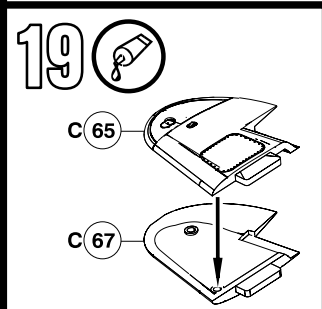
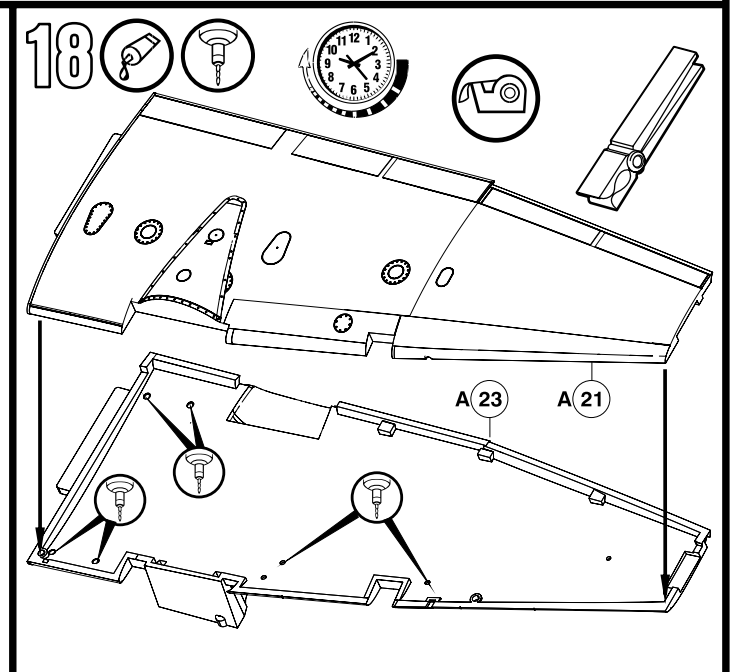
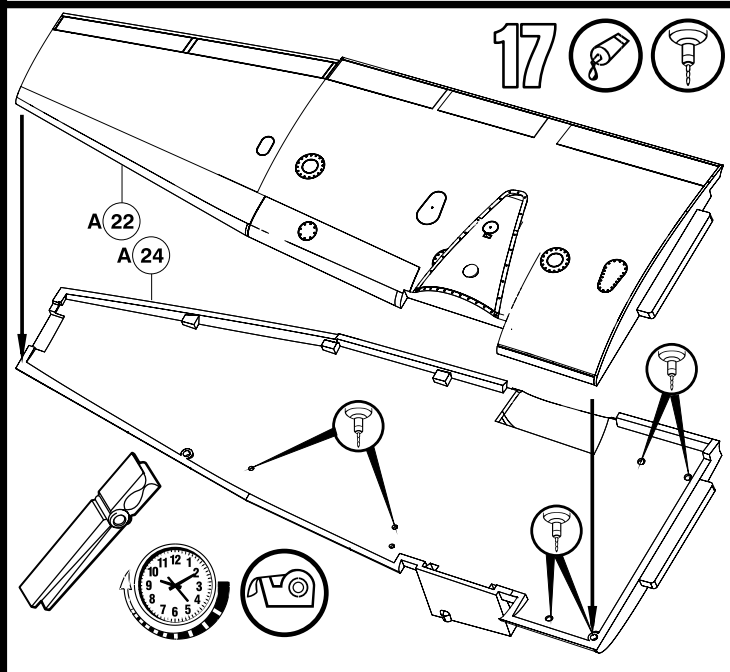
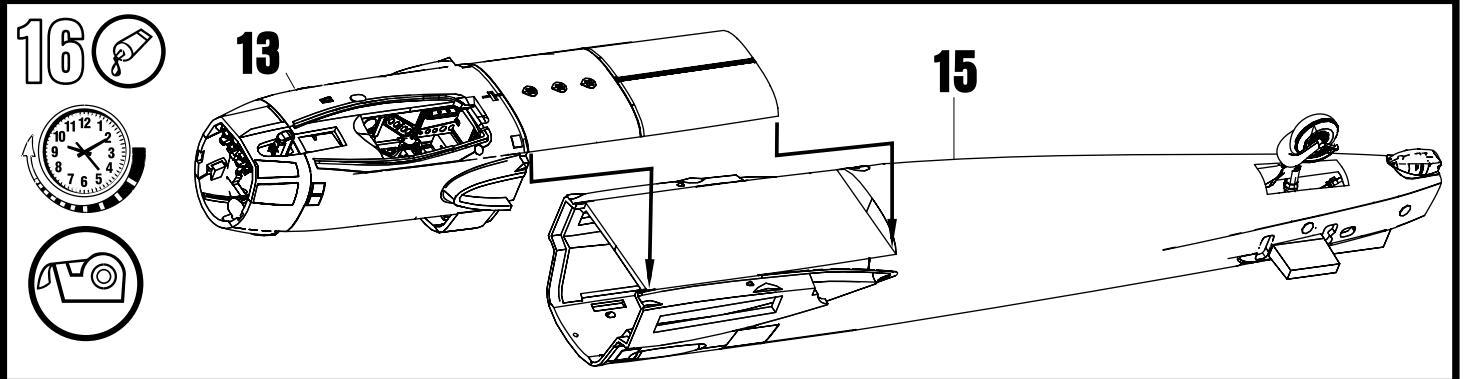
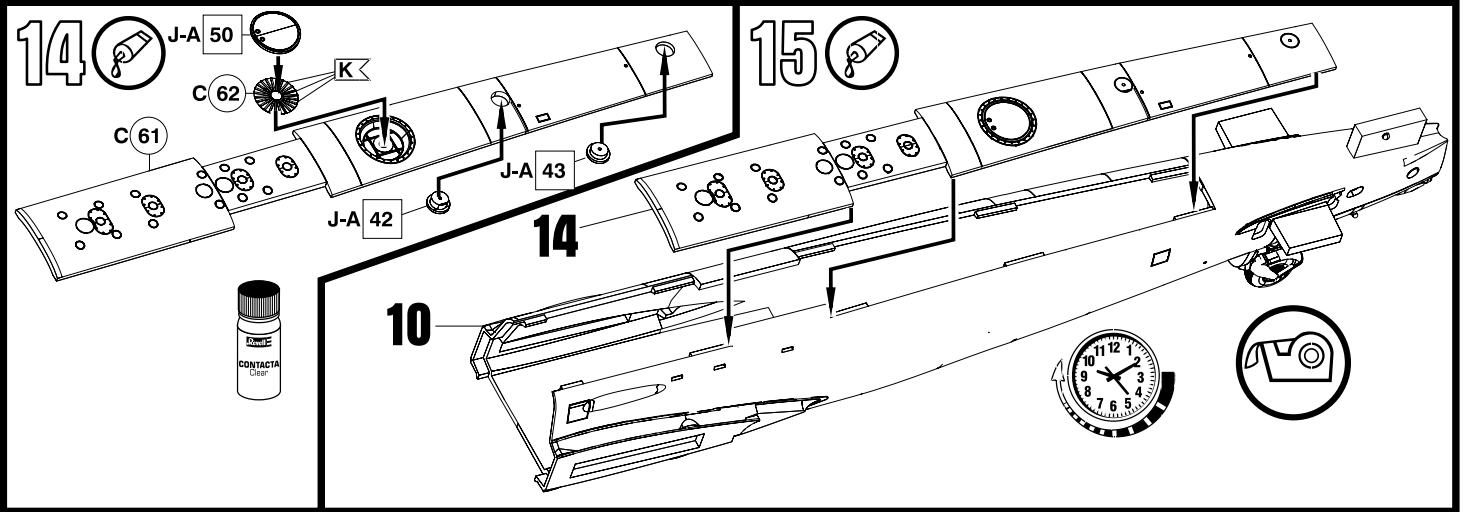

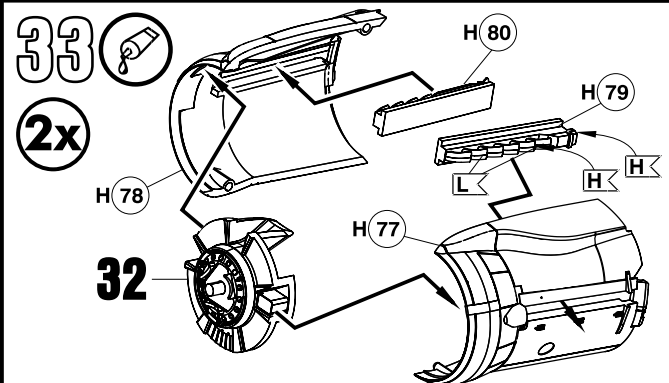
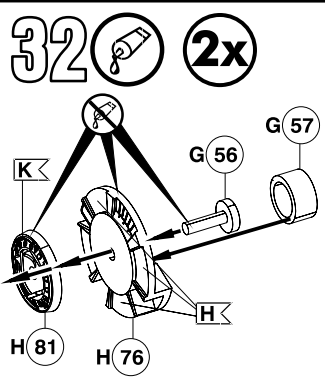
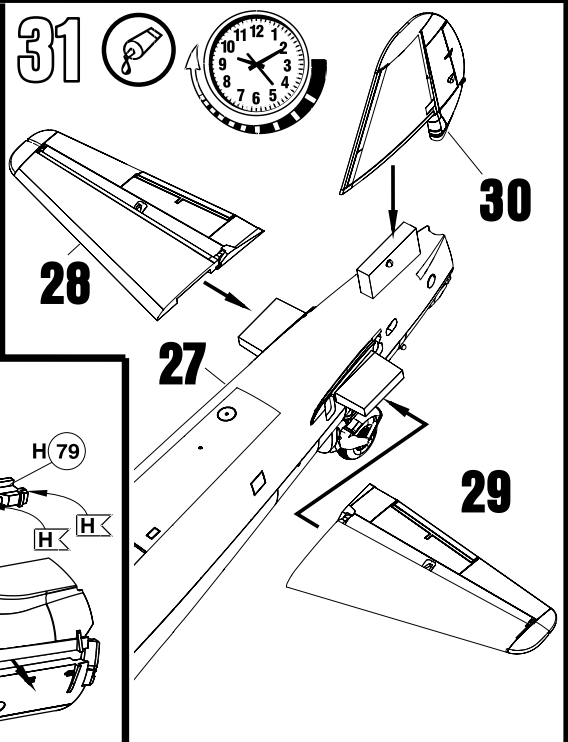
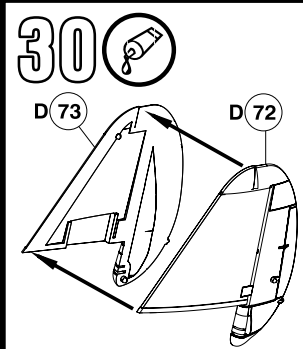
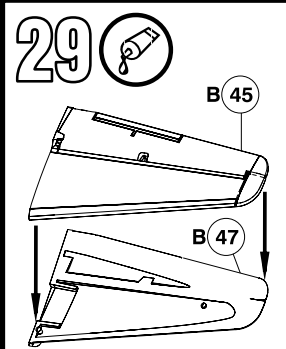
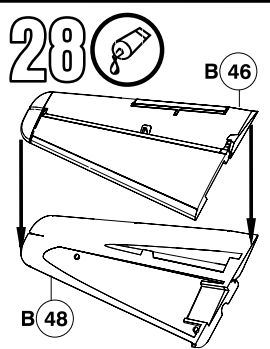
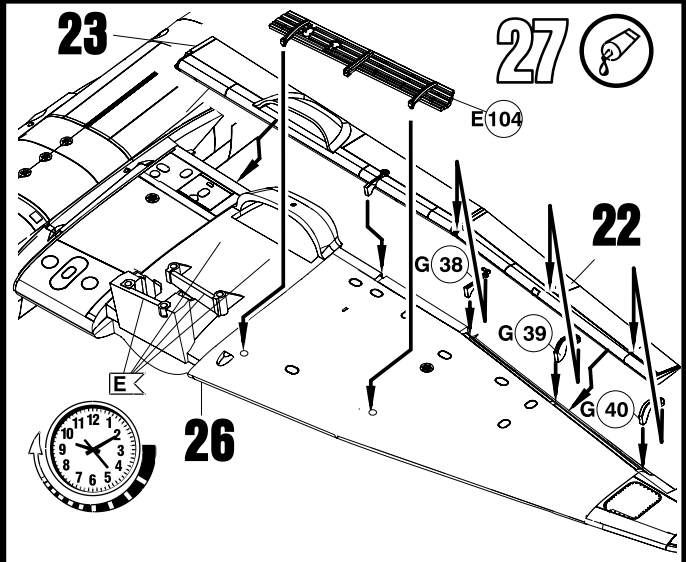
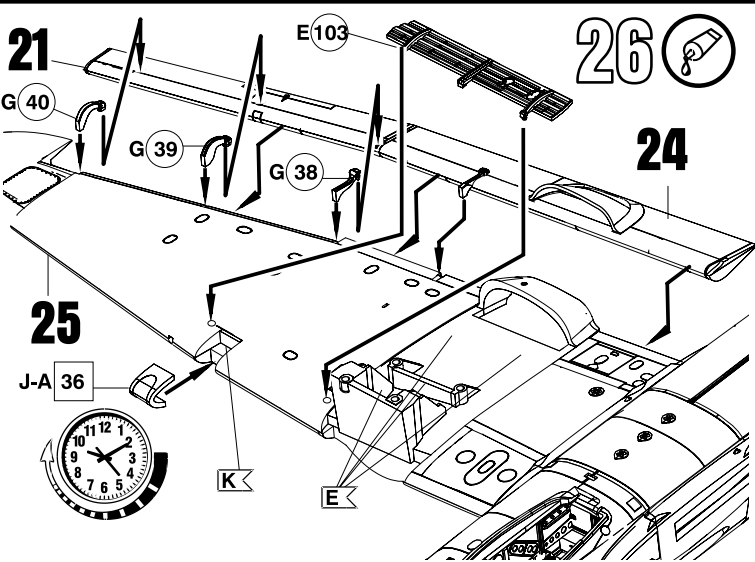
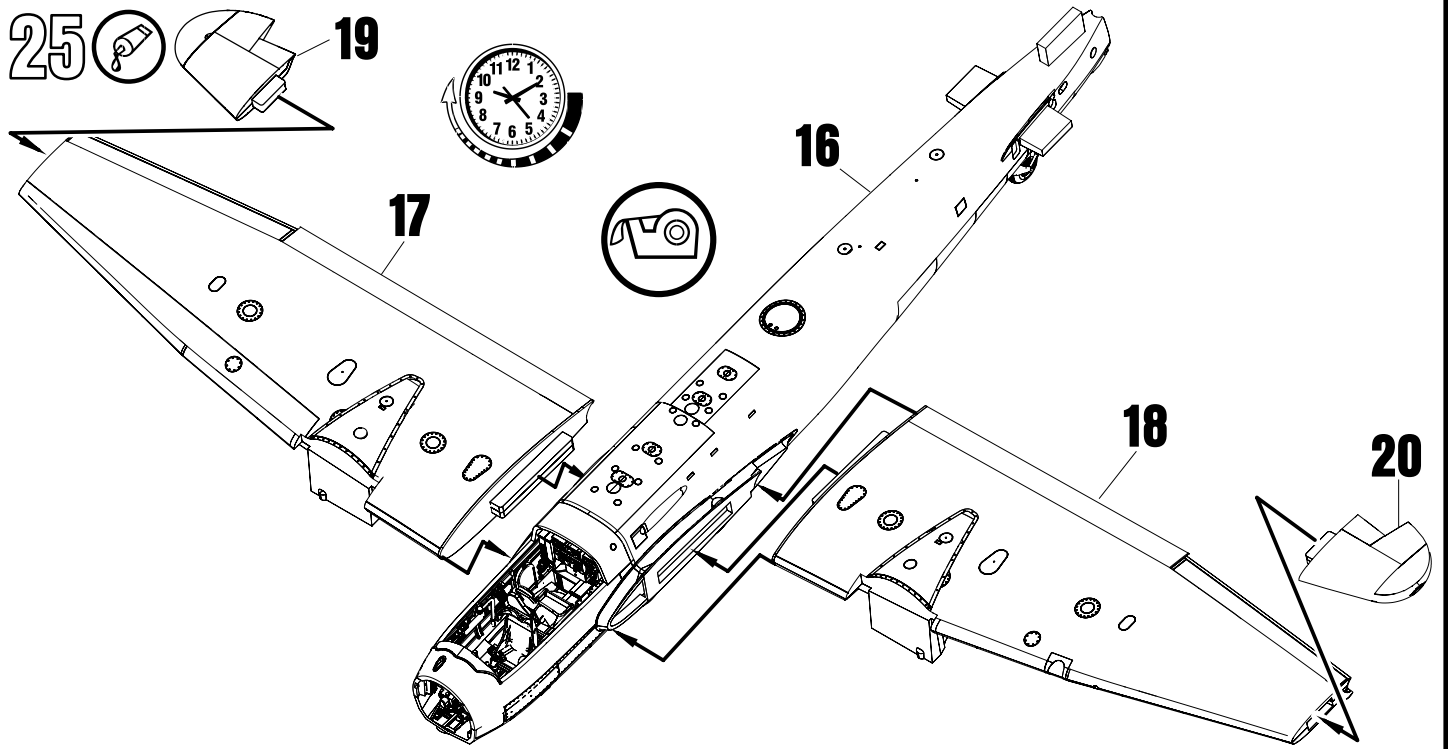

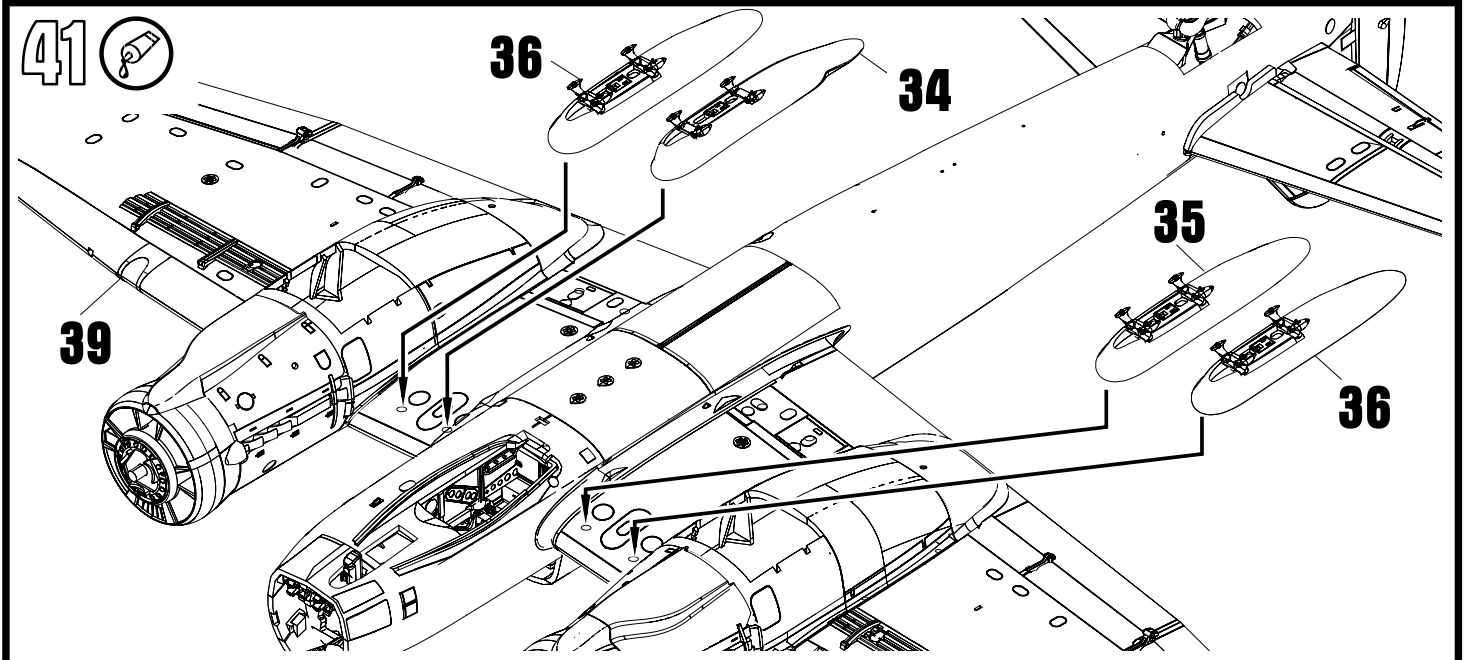
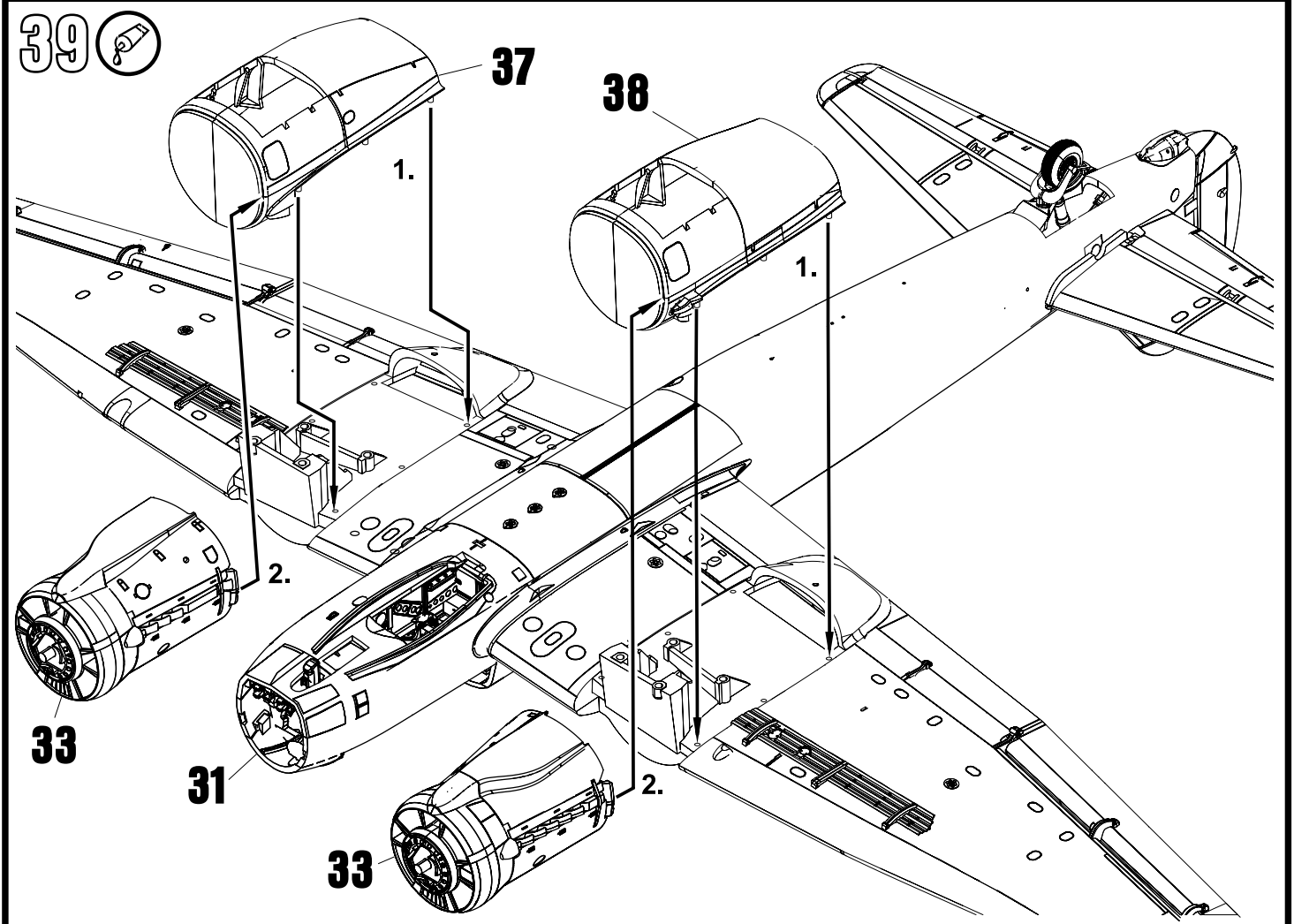
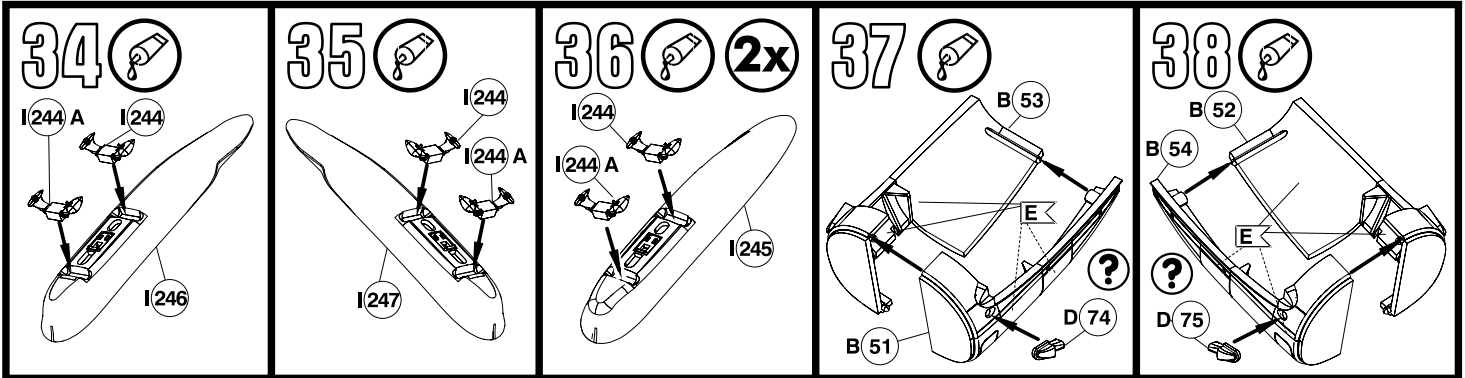

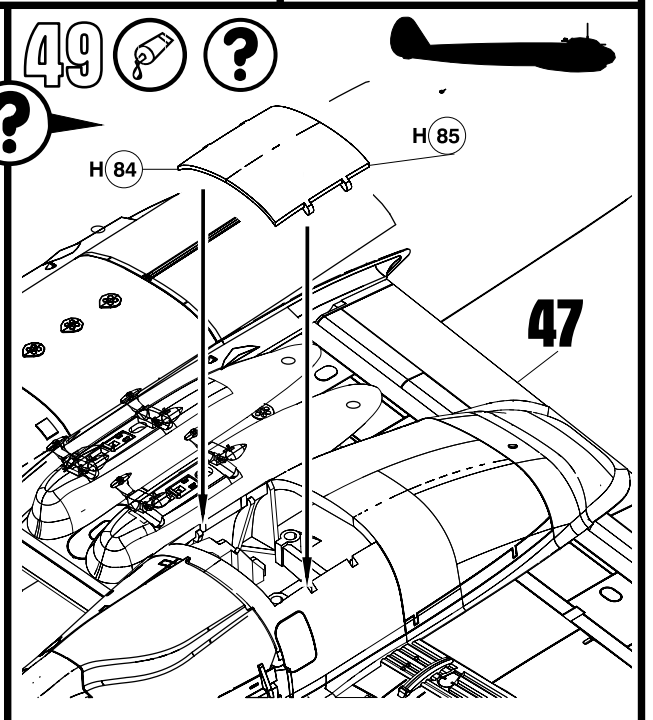
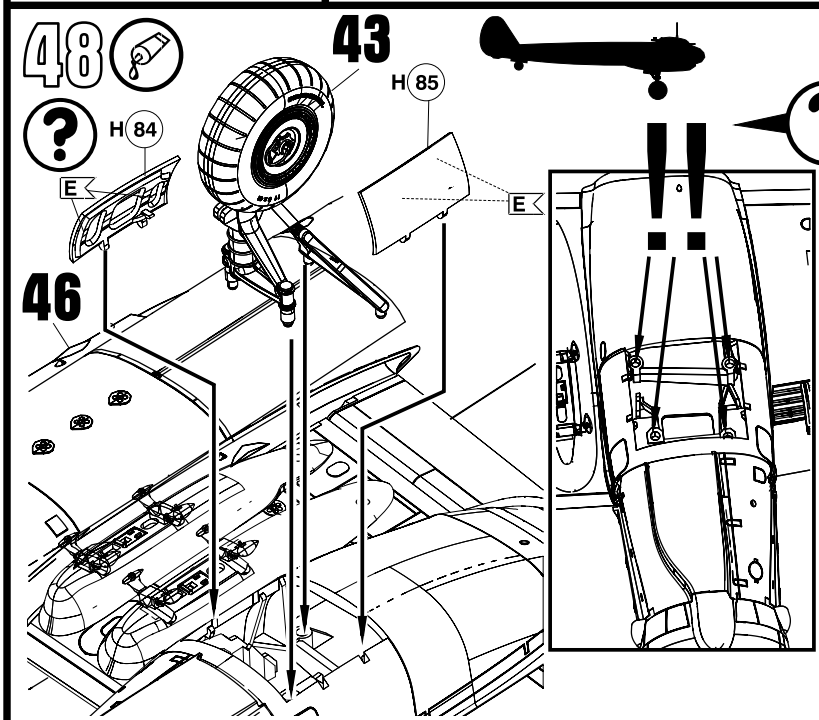
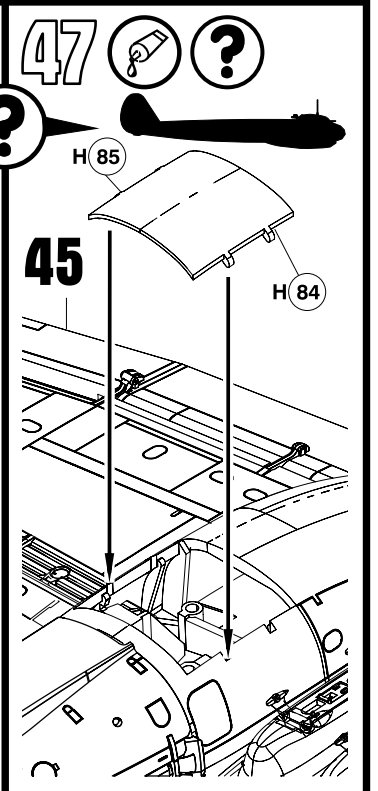
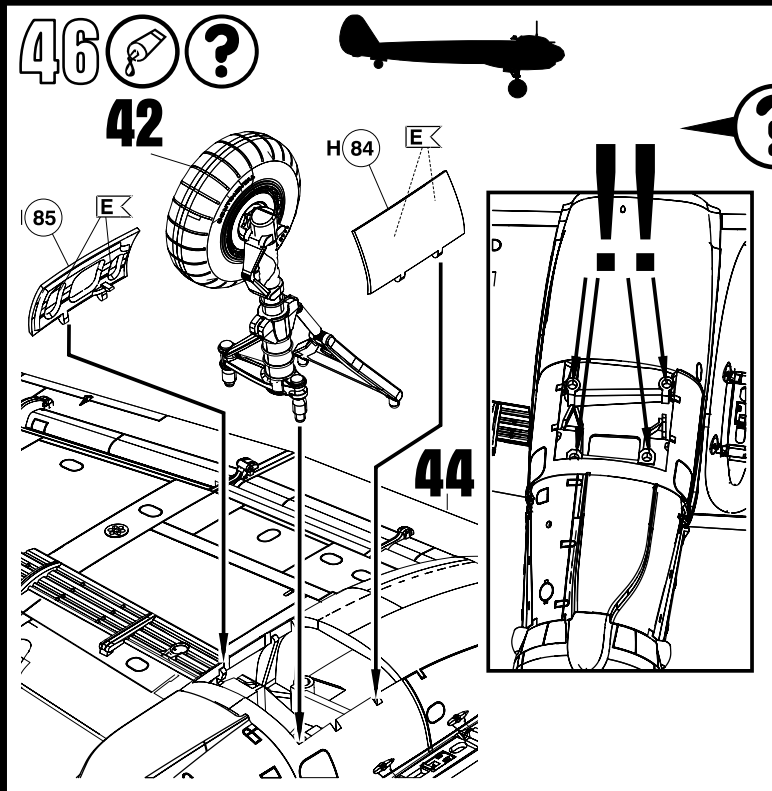
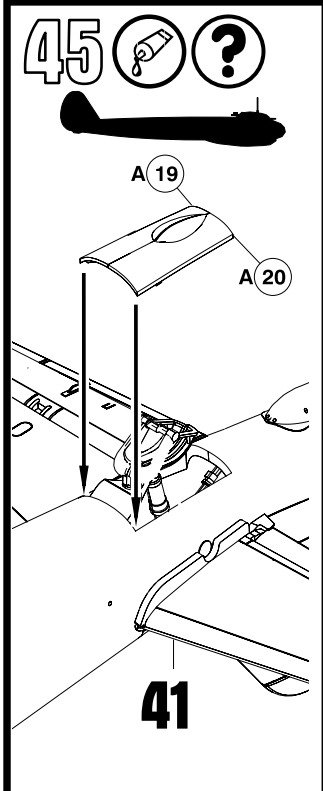
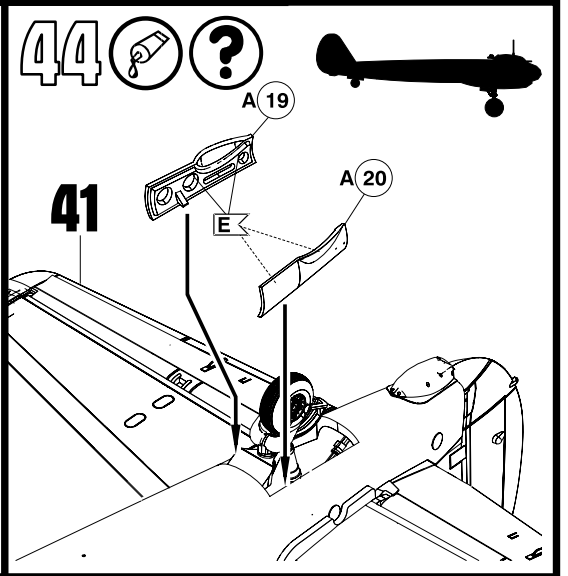
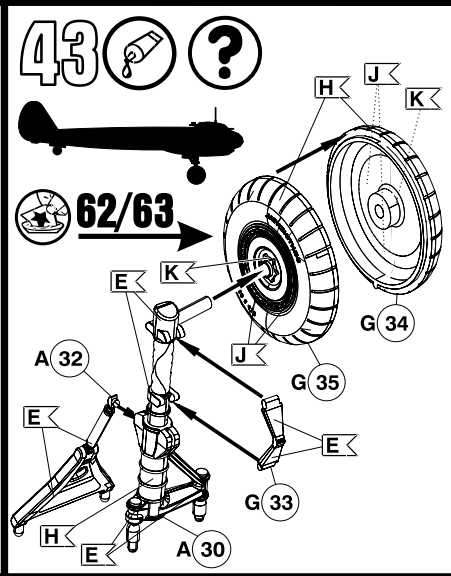
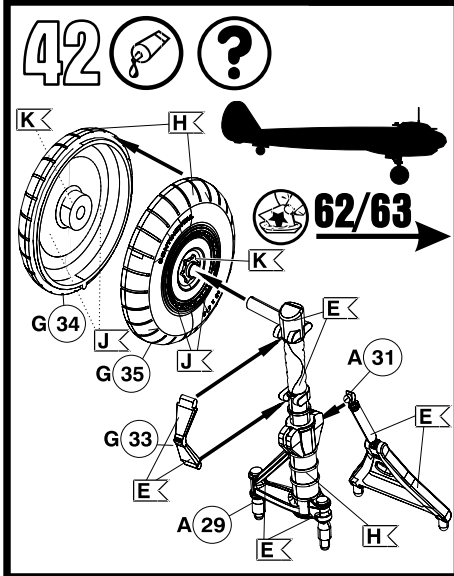

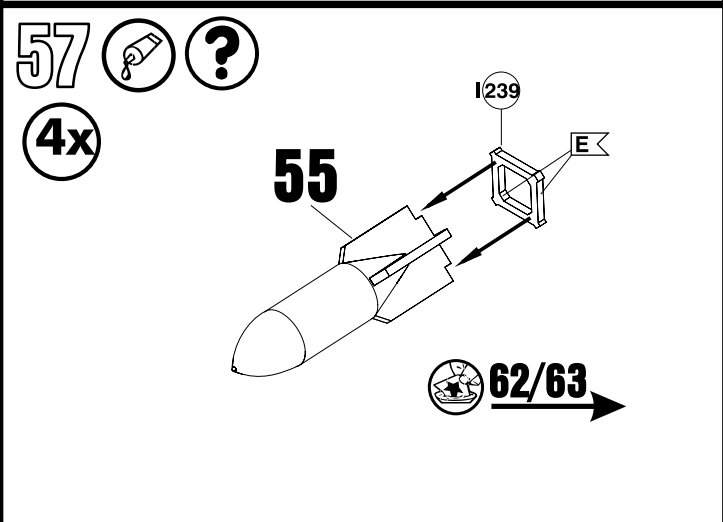
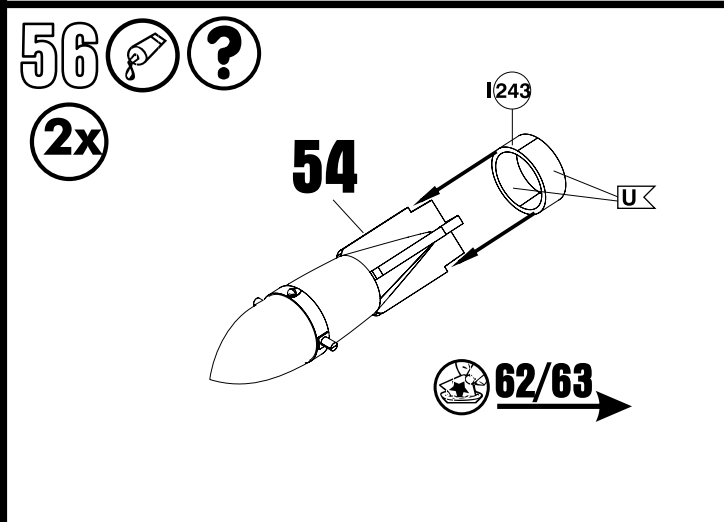
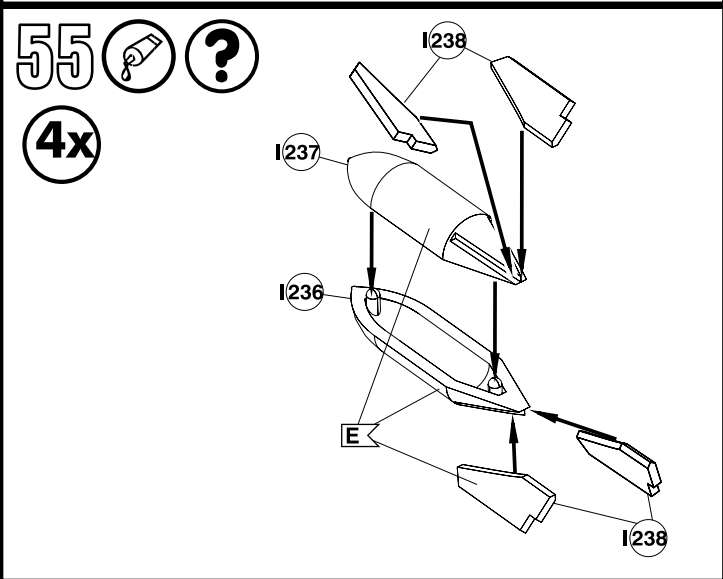
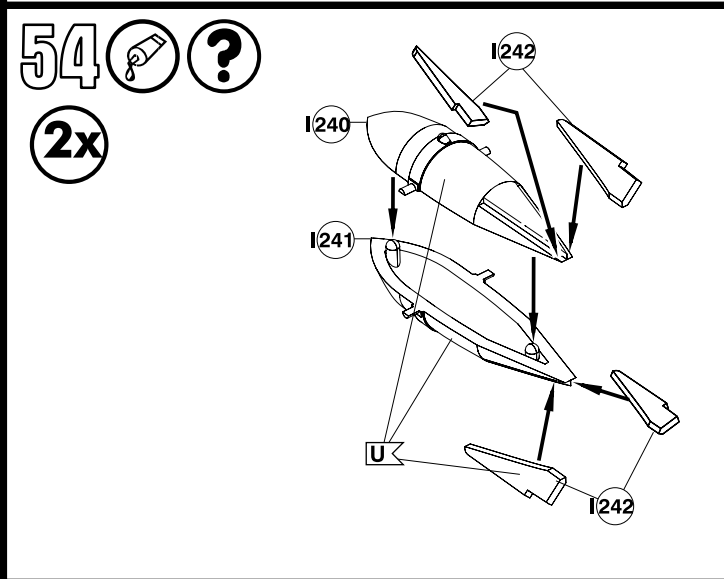
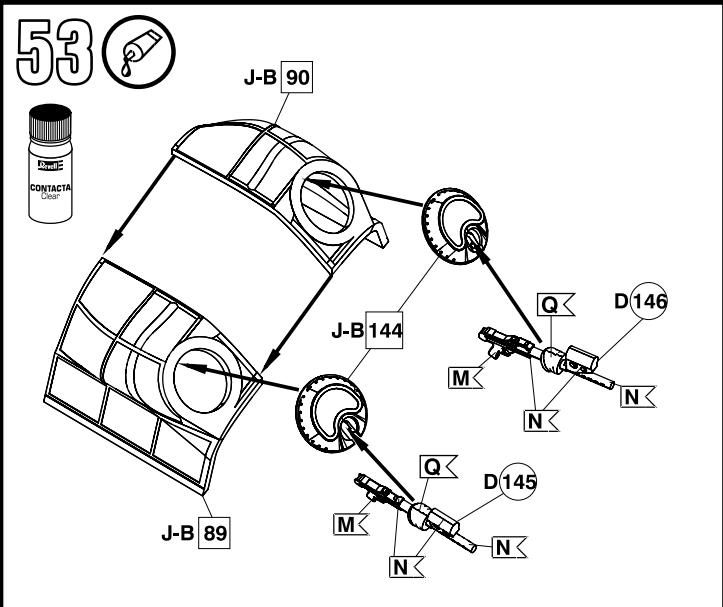
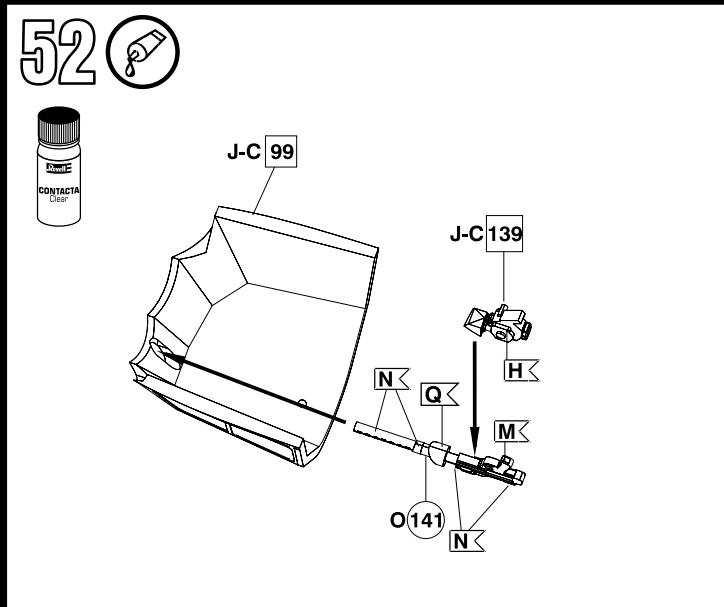
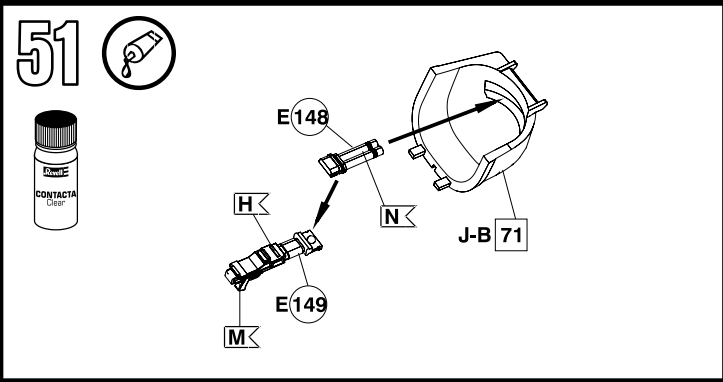
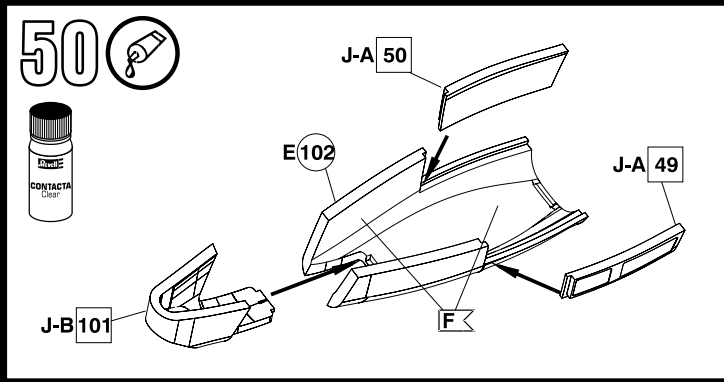

58  

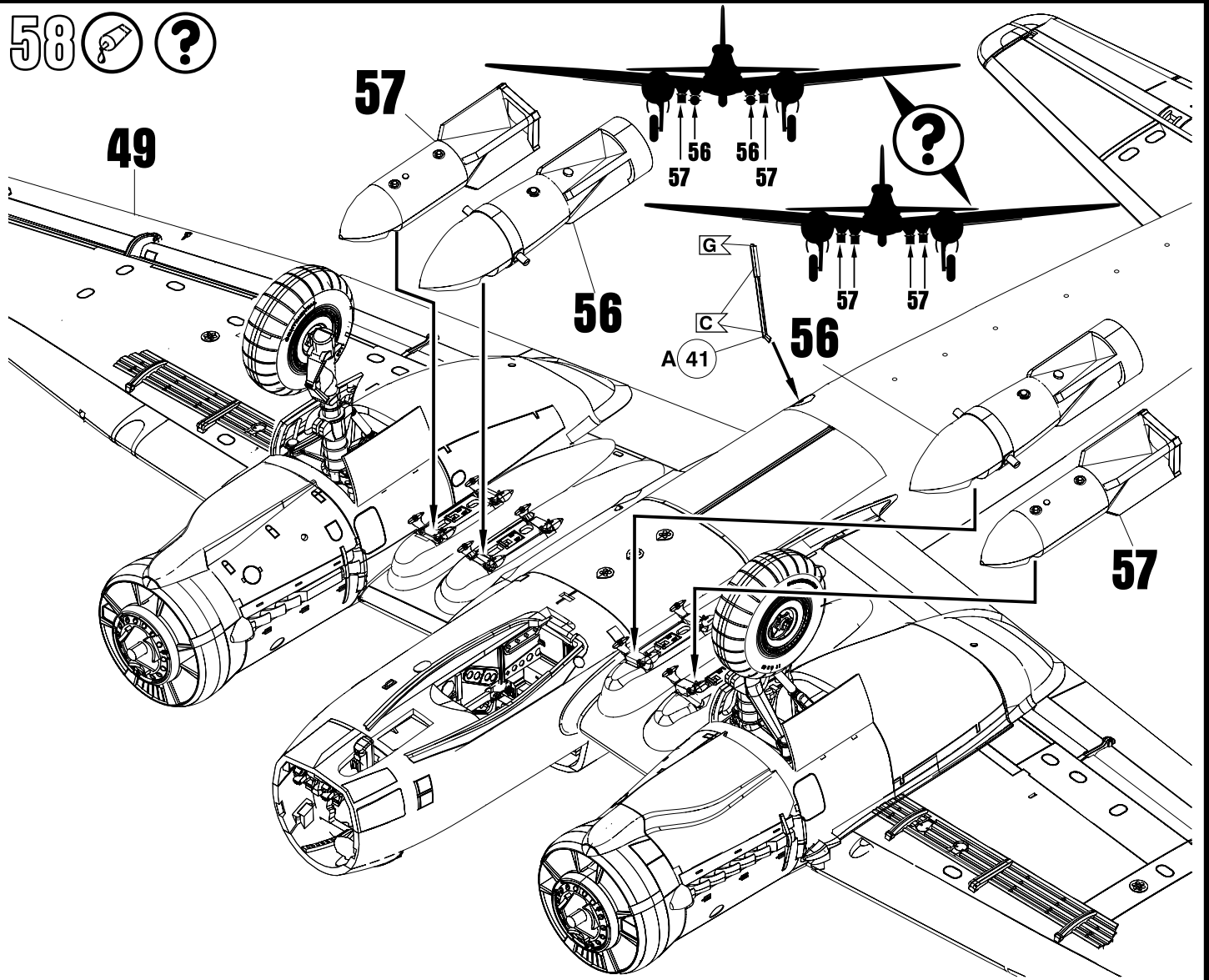

59 

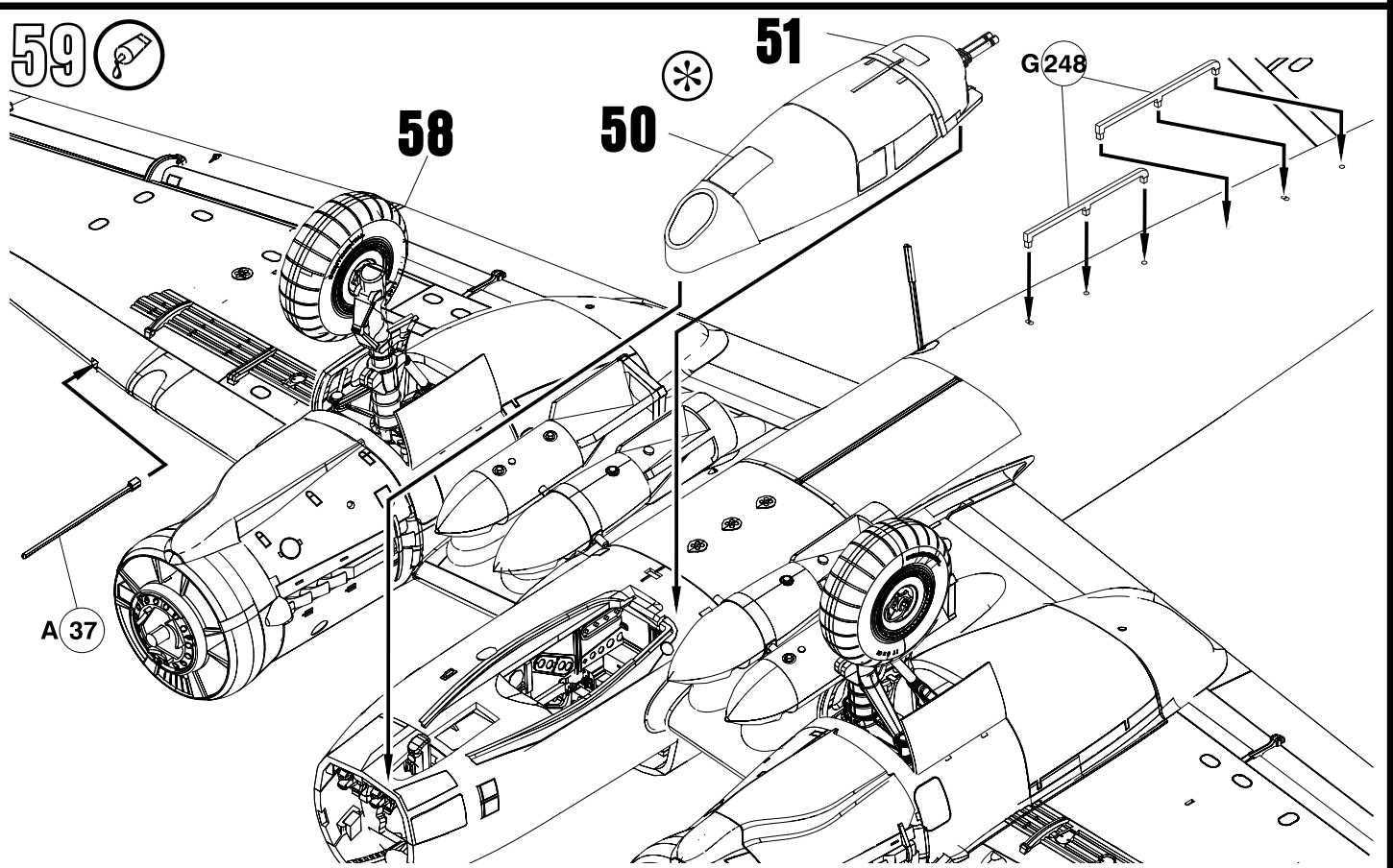

60 



B 58

52

53

2.

1.

59

61 

60



H 82

A

H 83

J-C 97

H 82

A

H 83



Junkers Ju 88A-4 of 9./KG 30 „Adler-Geschwader“
Catania, Sicily, Italy; June 1941

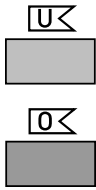
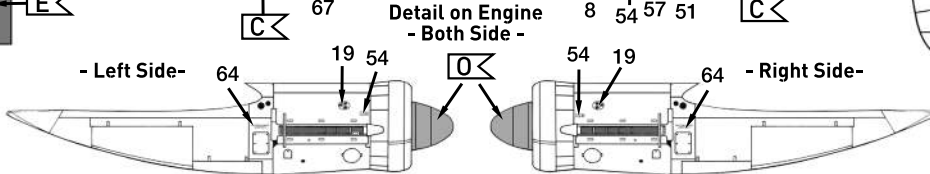
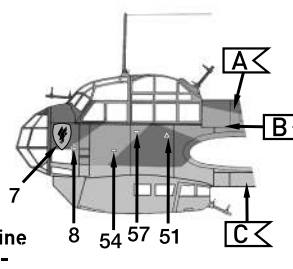
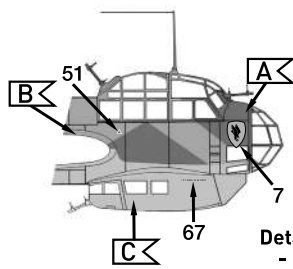
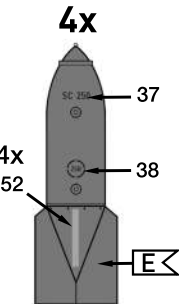
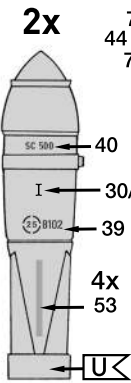
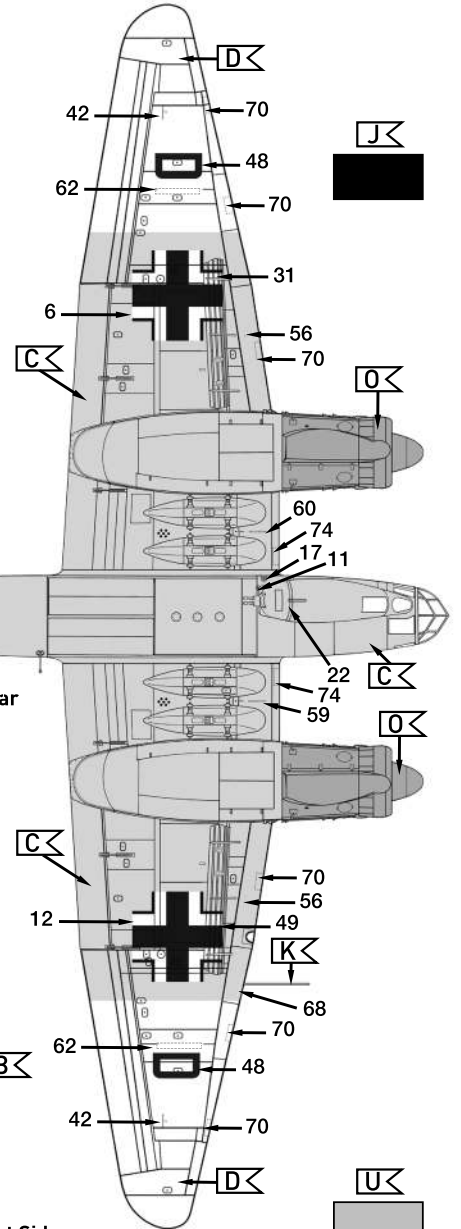
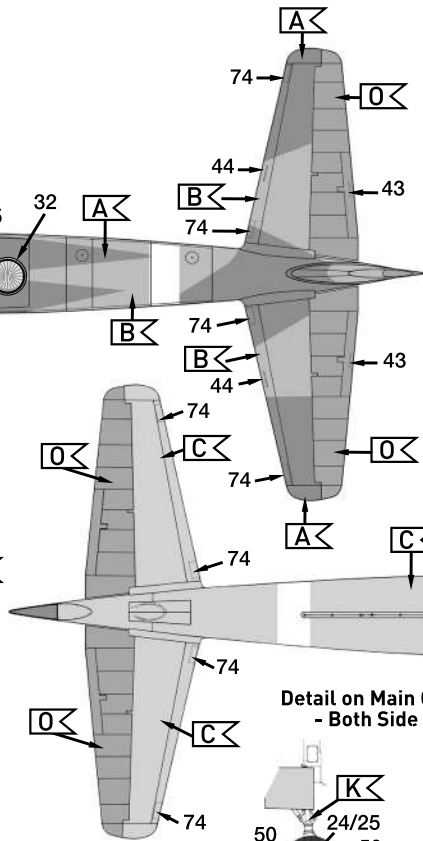
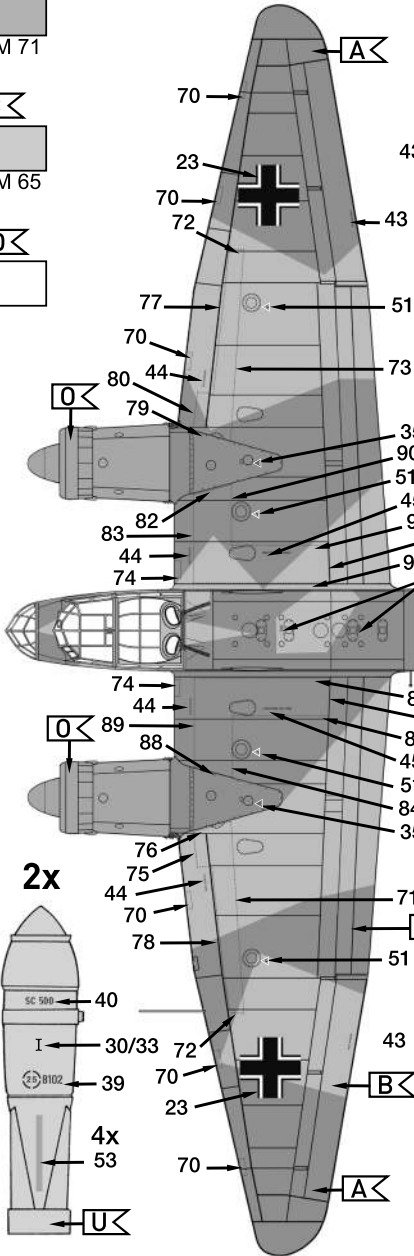
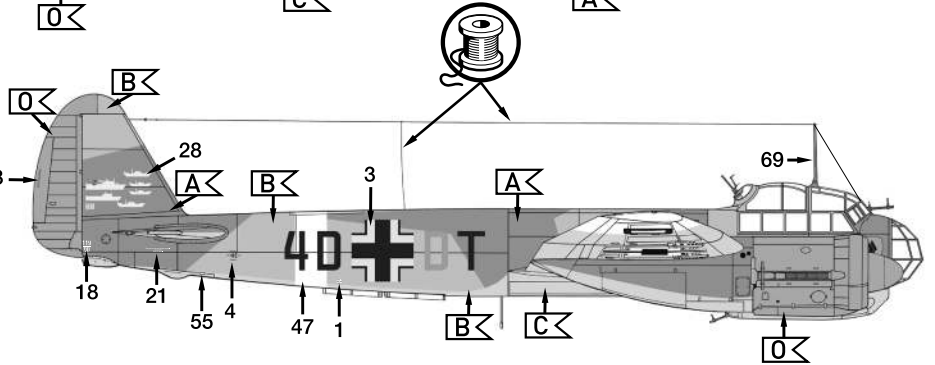
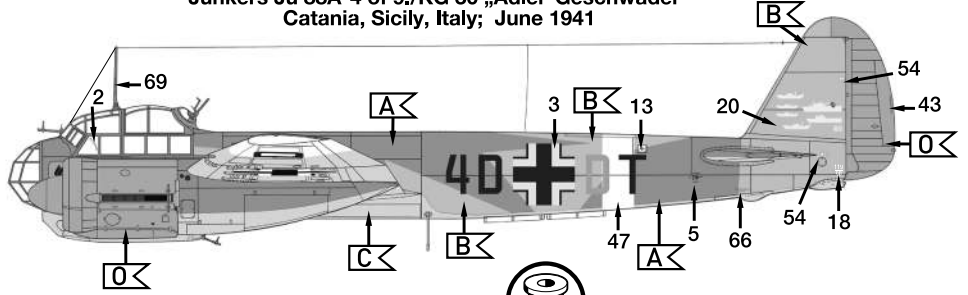
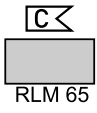
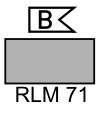
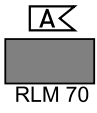



Junkers Ju 88A-4 of 5./Lehrgeschwader 1 (LG 1)
Eleusis, Greece; March 1942

- A**
- RLM 70
- B**
- RLM 71
- C**
- RLM 65
- E**

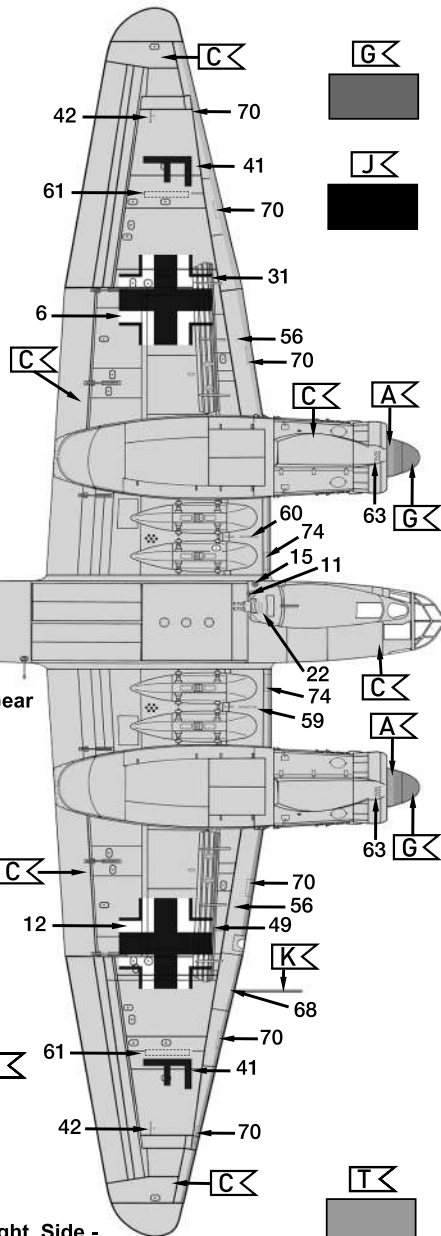
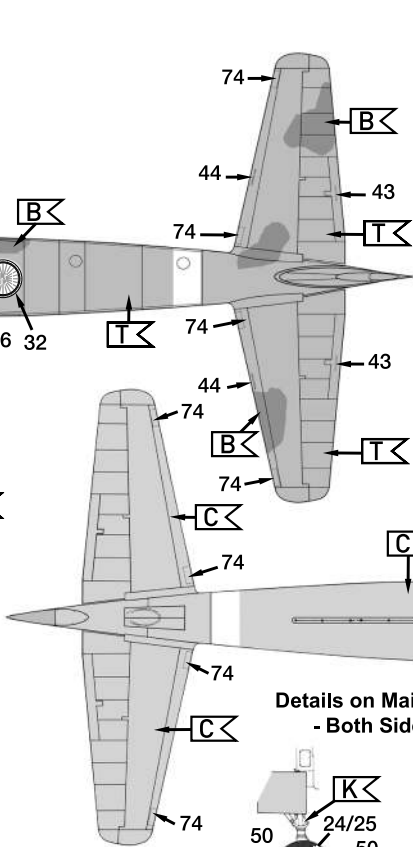
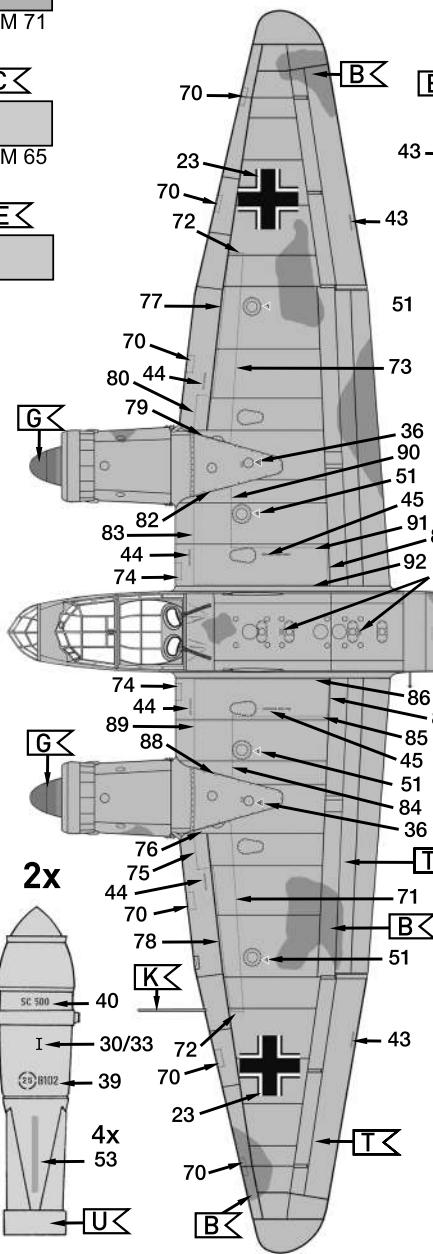
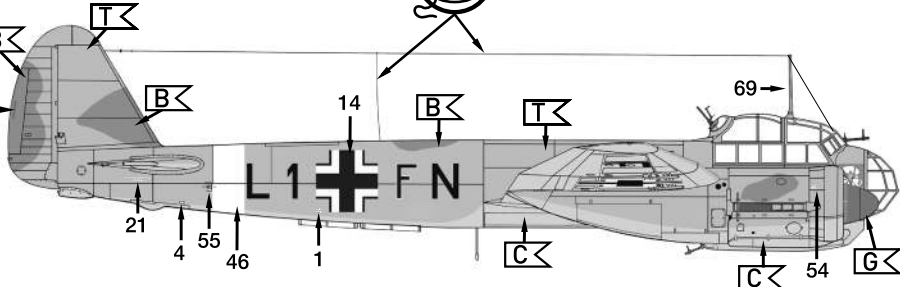
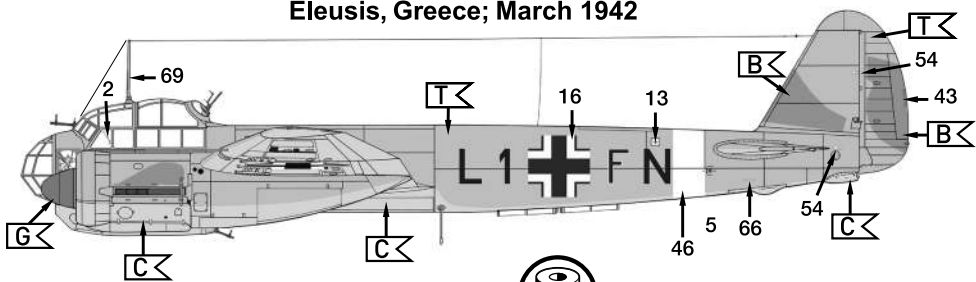

Details on Main Gear - Both Side -

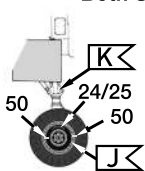

Details on Engine - Both Side -

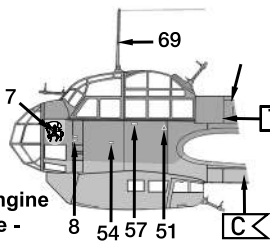

- Right Side -

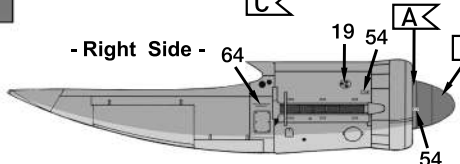

- Right Side -

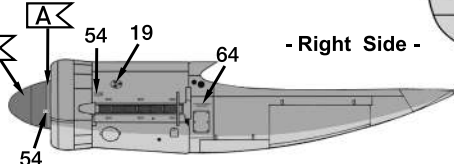

- T**
- J**
- K**
- U**