



07434-0379

LEVEL 5

1 2 3 4 5



'65 CORVETTE® STING RAY™

Beiliegenden Sicherheitstext beachten / Please note the enclosed safety advice

- Ⓔ Beiliegenden Sicherheitstext beachten und nachschlagbereit halten.
- ⒸⒺ Please note the enclosed safety advice and keep safe for later reference.
- Ⓕ Respecter les consignes de sécurité ci-jointes et les conserver à portée de main.
- Ⓖ Houdt u aan de bijgaande veiligheidsinstructies en hou deze steeds bij de hand.
- Ⓣ Seguire le avvertenze di sicurezza allegate e tenerle a portata di mano.
- Ⓔ Observar y siempre tener a disposición este texto de seguridad adjunto.
- Ⓟ Ter em atenção o texto de segurança anexo e guardá-lo para consulta.

- Ⓒ Overhold vedlagte sikkerhedsanvisninger og hav dem liggende i nærheden.
- ⓃⒺ Ha alltid vedlagt sikkerhetstekst klar til bruk.
- Ⓔ Beakta bifogad säkerhetstext och håll den i beredskap.
- Ⓕ Huomioi ja säilytä oheiset varoitukset.
- Ⓔ Соблюдать технику безопасности, сохранить инструкцию для дальнейших обращений.
- Ⓕ Przestrzegaj załączonego tekstu dotyczącego bezpieczeństwa i miej go zawsze pod ręką.
- Ⓔ Dodržujte tento priložený bezpečnostní text a mějte ho po ruce.
- Ⓕ A mellékelt biztonsági szöveget vegye figyelembe és tartsa fellepozásra készen.

- Ⓔ Respektujte priložený bezpečnostní text a uchovajte ho pre budúce použitie.
- Ⓔ Respectați textul de siguranță atașat și păstrați-l la îndemână.
- Ⓔ Спазвайте приложениа текст за безопасност и го дръжте под ръка за справки.
- Ⓔ Prilolena varnostna navodila izvajajte in jih hranite na vsem dostopnem mestu.
- Ⓔ Λάβετε υπόψη σας το συννημένο κείμενο ασφαλείας και φυλάξτε το ώστε να ανατρέχετε σε αυτό όποτε χρειάζεται.
- Ⓔ Ektekiqüvenlik talimatlarını dikkate alıp, bakabileceğiniz bir şekilde muafaza ediniz.



☞ Weitere Tipps und Tricks.
 ☞ Additional tips and tricks.
 ☞ Conseils et astuces supplémentaires.
 ☞ Andere tips en trucs.
 ☞ Ulteriori consigli e suggerimenti.
 ☞ Consejos y sugerencias adicionales.
 ☞ Mais dicas e truques.

☞ Flere tips og tricks.
 ☞ Flere tips og tricks.
 ☞ Ytterligare tips och tricks.
 ☞ Lisää vinkkejä ja niksejä.
 ☞ Другие советы и хитрости.
 ☞ Dalsze wskazówki i sugestie.
 ☞ Další tipy a rady.
 ☞ További ötletek és fogások.
 ☞ Dalsie tipy a triky.
 ☞ Alte sfaturi și trucuri.

☞ Други полезни съвети и трикове.
 ☞ Nadaljnji nasveti in zvižaje.
 ☞ Πρόσθετες συμβουλές και κόλπα.
 ☞ Diğer öneriler ve ipuçları.

www.revell.de



- DE Kleben
- FR Glue
- FR Collee
- NL Lijmen
- IT Incollare
- ES Pegamento
- PT Colar
- DK Lim
- NO Lime
- SE Limma
- FI Liimaa
- RU Клеить
- PL Przykleić
- CZ Slepění
- HU Ragassza rá
- SK Lepiť
- NO Lipiti
- NO Zalepете
- SI Prilepite
- GR ΚΟΛΛΗΣΤΕ
- TR Yapıştırma



- DE Nicht kleben
- FR Don't glue
- FR Ne pas colle
- NL Niet lijmen
- IT Non incollare
- ES No pegamento
- PT Não colar
- DK Lim ikke
- NO Ikke lime
- SE Limma inte
- FI Älä liimaa
- RU Не клеить
- PL Nie przyklejać
- CZ Nelepít
- HU Ne ragassza rá
- SK Nelepít
- NO Nu lipiti
- NO Не лепете
- SI Ne lepите
- GR Μην κολλάσετε
- TR Yapıştırmayın



- DE Bemalen
- FR Paint
- FR Peindre
- NL Beschilderen
- IT Colorare
- PT Pintar
- DK Mal
- NO Male
- SE Måla
- FI Maalaa
- RU Раскрасить
- PL Pomalować
- CZ Natrief
- HU Fesse be
- SK Natrief
- NO Vopsiiti
- NO Боядисайте
- SI Pobarvajte
- GR Βάψτε
- TR Boyama



- DE Zusammenbau Reihenfolge.
- FR Sequence of assembly.
- FR Ordre d'assemblage.
- NL Volgorde van montage.
- IT Sequenza di assemblaggio.
- ES Secuencia de montaje.
- PT Sequência de montagem.
- DK Samlerækkefølge.
- NO Monteringsrekkefølge.
- SE Montering ordningsföljd.
- FI Kokoamisjärjestys.
- RU Последовательность сборки.
- PL Kolejność montażu.
- CZ Pořadí složení.
- HU Összerakási sorrend.
- SK Poradie zostavenia.
- NO Ordinea asamblării.
- NO Последовательность на сглобяване.
- SI Vrstni red sestavljanja.
- GR Σειρά τοποθέτησης.
- TR Parçaları birleştirme sırası.



- DE Anzahl der Arbeitsgänge.
- FR Number of working steps.
- FR Nombre d'étapes de travail.
- NL Het aantal bouwstappen.
- IT Numero di fasi di lavoro.
- ES Número de pasos de trabajo.
- PT Número de passos de trabalho.
- DK Antal arbejds-gange.
- NO Antall arbeidstrinn.
- SE Antal operationer.
- FI Työvaiheiden määrä.
- RU Количество операций.
- PL Liczba cykli roboczych.
- CZ Počet pracovních kroků.
- HU A munkanetemek száma.
- SK Počet pracovných operácií.
- NO Numărul etapelor de lucru.
- NO Брой работни стъпки.
- SI Število delovnih postopkov.
- GR Αριθμός βημάτων εργασίας.
- TR Çalışma adımı sayısı.



- DE Wahlweise
- FR Optional
- FR Facultatif
- NL Naar keuze
- IT Facoltativamente
- ES Opcional
- PT Opcional
- DK Valgfri
- NO Valgfritt
- SE Valfri
- FI Valinnaisesti
- RU На выбор
- PL Opcjonalnie
- CZ Volitelně
- HU Választás szerint
- SK Na výber
- NO Optional
- NO По избор
- SI Izbirno
- GR Προαιρετικά
- TR Opsiyonel



- DE Linke Seite
- FR Left side
- FR Côté gauche
- NL Linkerkant
- IT Lato sinistro
- ES Lado izquierdo
- PT Lado esquerdo
- DK Venstre side
- NO Venstre side
- SE Vänstra sida
- FI Vasen puoli
- RU Левая сторона
- PL Lewa strona
- CZ Levá strana
- HU Bal oldal
- SK Ľavá strana
- NO Latura stângă
- NO Лява страна
- SI Leva stran
- GR Αριστερή πλευρά
- TR Sol taraf



- DE Rechte Seite
- FR Right side
- FR Côté droit
- NL Rechterkant
- IT Lato destro
- ES Lado derecho
- PT Lado direito
- DK Højre side
- NO Høyre side
- SE Högra sida
- FI Oikea puoli
- RU Правая сторона
- PL Prawa strona
- CZ Pravá strana
- HU Jobb oldal
- SK Pravá strana
- NO Latura dreaptă
- NO Дясна страна
- SI Desna stran
- GR Δεξιά πλευρά
- TR Sağ taraf



- DE Bauteile trocknen lassen.
- FR Allow the parts to dry.
- FR Laisser sécher les pièces.
- NL Ouderdelen laten drogen.
- IT Lasciar asciugare i componenti.
- ES Dejar secar las piezas.
- PT Deixar as peças secar.
- DK Lad delene tørre.
- NO Tork komponenter.
- SE Låt komponenterna torka.
- FI Anna rakennneosien kuivua.
- RU Дайте деталям высохнуть.
- PL Pozostawić elementy konstrukcji do wyschnięcia.
- CZ Nechte díly uschnout.
- HU Hagyja megszáradni az alkatrészeket.
- SK Konštrukčné diely nechajte vyschnúť.
- NO Lásati componentele să se usuce.
- NO Оставете сглобените части да изсъхнат.
- SI Osušite sestavne dele.
- GR Αφήστε τα μέρη να στεγνώσουν.
- TR Yarı parçalarını kurumaya bırakın.



- DE Abbildung zusammengesetzter Teile.
- FR Illustration of assembled parts.
- FR Figure représentant les pièces assemblées.
- NL Afbeelding van samengevoegde onderdelen.
- IT Foto delle parti assemblate.
- ES Figura de las piezas montadas.
- PT Ilustração das peças montadas.
- DK Illustration af samlede dele.
- NO Figur av sammensatte deler.
- SE Bild på sammansatta detaljer.
- FI Koottujen osien kuva.
- RU Изображение смонтированных деталей.
- PL Rysunek połączonych części.
- CZ Zobrazení spojených dílů.
- HU Összerakott alkatrészek ábrája.
- SK Obrázok dielov, ktoré sa majú zmontovať.
- NO Figura reprezentând piesele asamblate.
- NO Изображение на сглобените части.
- SI Slika sestavljenih delov.
- GR Απεικόνιση των τοποθετημένων μερών.
- TR Birleştirilmiş parçalar resmi.



- DE Klarsichtteile
- FR Clear parts
- FR Pièces transparentes
- NL Transparente onderdelen
- IT Parti trasparenti
- ES Piezas transparentes
- PT Peças transparentes
- DK Klare dele
- NO Klare deler
- SE Genomsiktliga detaljer
- FI Läpinäkyvät osat
- RU Прозрачные детали
- PL Przejrzyste części
- CZ Průhledné díly
- HU Átlátszó alkatrészek
- SK Číre diely
- NO Piese transparente
- NO Прозрачни части
- SI Prozorni deli
- GR Διαφανή
- TR Şeffaf parçalar



- DE Chromteile
- FR Chrome parts
- FR Pièces chromées
- NL Chromo onderdelen
- IT Parti cromate
- ES Piezas cromadas
- PT Peças de cromo
- DK Forkromede dele
- NO Kromdeler
- SE Kromdetaljer
- FI Kromiosat
- RU Хромированные детали
- PL Części chromowane
- CZ Chromované díly
- HU Króm alkatrészek
- SK Chromované diely
- NO Piese cromate
- NO Хромови части
- SI Kromirani deli
- GR Μέρη χρωμίου
- TR Krom parçalar



- DE Gleichen Vorgang auf der gegenüberliegenden Seite wiederholen.
- FR Repeat same procedure on opposite side.
- FR Opérer de la même façon sur l'autre face.
- NL Dezelfde handeling herhalen aan de tegenoverliggende kant.
- IT Ripetere il procedimento dall'altra parte.
- ES Repetir el mismo procedimiento en el lado contrario.
- PT Repetir alguns procedimentos no lado oposto.
- DK Gentag proceduren på den modstående side.
- NO Gjenta samme forløp på motliggende side.
- SE Upprepa samma process på motsatta sidan.
- FI Toista menettely vastakkaisella puolella.
- RU Повторить такие же действия на противоположной стороне.
- PL Powtórzć te same czynności po przeciwniej stronie.
- CZ Stejný postup opakujte na protilehlé straně.
- HU Ismételje meg a műveletet az ellentétes oldalon.
- SK Rovnaký postup zopakujte na protilahlej strane.
- NO Repetați același procedeu pe latura opusă.
- NO Повторете същите стъпки на срещуположната страна.
- SI Enak postopek ponovite na nasprotni strani.
- GR Επαναλάβετε την ίδια διαδικασία στην αντίθετη πλευρά.
- TR Aynı işlem adimlarını diğer tarafta da uygulayın.



- DE Wegfeilen
- FR File off
- FR Enlever avec une lime
- NL Wegvijlen
- IT Rimuovere con una lima
- ES Limar
- PT Remover com uma lima
- DK Fil af
- NO File av
- SE Skall filas bort
- FI Hio pois
- RU Сточить напильником
- PL Odrpłować
- CZ Odrpílovať
- HU Reszelje le
- SK Odrpílovať
- NO Piliti
- NO Изпилете
- SI Odrpiliti
- GR Λιμαρώτε
- TR Zımparalama



- DE Papierbild ausschneiden und kleben.
- FR Cut out paper picture and glue.
- FR Découper la photo et la coller.
- NL Papiertekening uitknippen en lijmen.
- IT Ritagliare l'immagine di carta e incollarla.
- ES Recortar la imagen de papel y pegar.
- PT Recortar a imagem de papel e colar.
- DK Klip papirbilledet ud og lim det.
- NO Klippe ut papirbilde og lime.
- SE Klipp ut och limma pappersbild.
- FI Leikkaa ja liimaa paperikuva.
- RU Вырезать и приклеить бумажную картинку.
- PL Wyciąć papierowy obrazek i przykleić.
- CZ Vystihněte papírový obrázek a nalepte.
- HU Vágja ki és ragassza rá a papirképet.
- SK Vystihnite papierový obrázok a nalepte.
- NO Decurpați imaginea pe hârtie și lipiți-o.
- NO Изрежете и залепете хартиената картинка.
- SI Izrežite papirno sliko in prilepite.
- GR Κόψτε τη χαρτινή εικόνα και κολλήστε τη.
- TR Kağıt resmi kesin ve yapıştırın.



- DE Abziehbild in Wasser einweichen und anbringen.
- FR Soak and apply decals.
- FR Mouiller et appliquer les décalcomanies.
- NL Transfer in water even laten waken en aanbrengen.
- IT Immergere la decalcomania nell'acqua e applicarla.
- ES Mojar y aplicar calcomanias.
- PT Amolecer o decalque em água e aplicar.
- DK Gør overføringsbilledet vådt og sæt det på.
- NO Myk opp avtrekingsbildet i vann og sett på.
- SE Blötlägg dekalen i vatten och sätt på den.
- FI Pehmitä siirtokuvaa vedessä ja siirtä raikalleen.
- RU Опустите переводную картинку в воду и нанесите её.
- PL Namoczyc kalkomanie w wodzie i przykleić.
- CZ Nechte obtisk odmočit ve vodě a přilepte.
- HU Merítse vízbe és helyezze fel a matricát.
- SK Obtlačkový obrázok namočte do vody a priložte na plochu.
- NO Inmuiți abțibildul în apă și aplicați-l.
- NO Потопете ваденката във вода и я поставете.
- SI Preperlico namakajte v vodi. In namestite.
- GR Μουσκεψτε σε νερό και τοποθετήστε τις χαλκομανίες.
- TR Çikartmayı suda yumuşatın ve takın.



- DE Zur Anbringung der Chromteile empfohlen.
- FR Recommended for attaching the chrome parts.
- FR Conseillé pour le montage des pièces chromées.
- NL Aanbevolen voor monteren chromo delen.
- IT Consigliato per applicare le parti cromate.
- ES Recomendado para la fijación de piezas de cromo.
- PT Recomendado para a aplicação das peças em cromo.
- DK Anbefales til placering af kromdelene.
- NO Anbefales til montering av kromdeler.
- SE Rekommenderad för montering av kromdetaljerna.
- FI Suositellaan kromiosien siirtämiseen.
- RU Рекомендуются для крепления хромированных деталей.
- PL Zalecane do mocowania elementów chromowanych.
- CZ Doporučujeme umiestnení chromových dílů.
- HU A króm darabok felhelyezéséhez ajánlott.
- SK Odporúčame pre umiestnenie chrómových dielov.
- NO Recomandat pentru ataşarea pieselor din crom.
- NO Препоручва се за поставяне на хромови части.
- SI Pri nameščanju kromiranih delov priporočamo.
- GR Συνιστάται για την τοποθέτηση των ελαστρομένων χρωμίου.
- TR Krom parçaların yapıştırılması için önerilir.



- DE Zur Anbringung der Abziehbilder empfohlen.
- GB Recommended for affixing the decals.
- FR Recommandé pour l'application des décalcomanies.
- NL Aanbevolen voor het aanbrengen van de transfers.
- IT Raccomandato per l'applicazione delle decalcomanie.
- ES Recomendado para fijar bien las calcomanías.
- PT Recomendado para a fixação dos autocolantes.
- DK Anbefales til anbringelse af overføringsbillederne.
- NO Anbefales til å feste avtrekksbilder.
- SE Rekommenderad för montering av klisterdekalerna.
- FI Suositellaan siirtokuvien siirtämiseen.
- RU Рекомендуется для нанесения переводных картинок.
- PL Zalecane do przyklejenia kalkomanii.
- CZ Doporučujeme k umístění obtiskovacích obrázků.
- HU A matrica felhelyezéséhez ajánlható.
- SK Odporúča sa pre umiestnenie obtlačkového obrázku.
- RO Recomandat pentru aplicarea obtărilor.
- BG Препоръчва се за поставяне на ваденки.
- GR Συνιστάται για την τοποθέτηση των χαλκομανιών.
- TR Çıkartmaların takılması için önerilir.



- DE Zur Anbringung der Klarteile empfohlen.
- GB Recommended to fix clear parts.
- FR Recommandé pour fixer les pièces transparentes.
- NL Aanbevolen voor het aanbrengen van transparante delen.
- IT Raccomandato per l'applicazione delle parti trasparenti.
- ES Recomendado para fijar las piezas transparentes.
- PT Recomendado para a aplicação das peças transparentes.
- DK Anbefales til anbringelse af de klare dele.
- NO Anbefales til å feste klare deler.
- SE Rekommenderad för montering av de genomskinliga detaljerna.
- FI Suositellaan läpinäkyvien osien siirtämiseen.
- RU Рекомендуется для крепления прозрачных деталей.
- PL Zalecane do przyklejenia przezroczystych części.
- CZ Doporučujeme k umístění průhledných dílů.
- HU Az átlátszó darabok felhelyezéséhez ajánlható.
- SK Odporúča sa pre umiestnenie čírych dielov.
- RO Recomandat pentru aplicarea pieselor transparente.
- BG Препоръчва се за поставяне на прозрачни части.
- GR Συνιστάται για την τοποθέτηση των διάφανων μερών.
- TR Şeffaf parçaların takılması için önerilir.



- DE Nicht enthalten
- GB Not included
- FR Non fourni
- NL Behoort niet tot de levering
- IT Non incluso
- ES No incluido
- PT Não incluído
- DK Medfølger ikke
- NO Ikke inkludert
- SE Ingår ej
- FI Ei sisällä
- RU Не содержится
- PL Nie wchodzi w zakres dostawy
- CZ Není obsaženo
- HU Nem tartalmazza
- SK Neobsahuje
- RO Nu este inclus
- BG Не се включва в комплекта
- GR Ni priloženo
- TR Δεν περιλαμβάνεται
- TR İçermiyor

Benötigte Farben / Required colours

FR Peintures nécessaires
NL Benodigde kleuren
IT Colori necessari
ES Colores necesarios
PT Cores necessárias
DK Nødvendige farver
NO Nødvendige farger
SE Erforderliga färger
FI Tarvittavat värit
RU Необходимые краски
PL Potrzebne kolory
CZ Potřebné barvy
HU Szükséges színek
SK Požadované farby
RO Culori necesare
BG Необходими цветове
SI Potrebne barve
GR Απαιτούμενα χρώματα
TR Gerekli renkler

99

A

DE Aluminium metallic
GB Aluminium metallic
FR Aluminium métallique
NL Aluminium metallic
IT Alluminio metallico
ES Aluminio metálico
PT Alumínio metálico
DK Aluminium metallisk
NO Aluminium metallic
SE Aluminium metallic
FI Alumiini metallinen
RU Алюминий металли
PL Aluminium metaliczny
CZ Hliníková metalizová
HU Alumínium metál
SK Hliníková metaliza
RO Aluminiu metalic
BG Алюминий металик
SI Aluminijasta kovinska
GR Αλουμίνιο μεταλλικό
TR Alüminyum grisi metalik

302

B

DE Schwarz seidenmatt
GB Black silk matt
FR Noir satiné mat
NL Zwart zijdemat
IT Nero opaco satinato
ES Negro mate satinado
PT Preto mate sedoso
DK Sort silkematt
NO Sort silkematt
SE Svart sidenmatt
FI Musta silkkimatta
RU Чёрный шелковисто-матовый
PL Czarny jedwabście matowy
CZ Černá jemně matný
HU Fekete, fakóselymes
SK Čierna hodvábné matný
RO Negru satinat
BG Черно коприненоматово
SI Črna svilenomat
GR Μαύρο σατινέ
TR Siyah ipeksi mat

90

C

DE Silber metallic
GB Silver metallic
FR Argent métallique
NL Zilver metallic
IT Argento metallico
ES Plata metálico
PT Prata metálico
DK Sølv metallisk
NO Sølv metallic
SE Silver metallic
FI Hopea metallinen
RU Серебрянный металик
PL Srebrny metaliczny
CZ Stříbrná metalizová
HU Ezüstmetál
SK Strieborná metaliza
RO Argintiu metalic
BG Сребро металик
SI Srebrna kovinska
GR Ασημί μεταλλικό
TR Gümüş rengi metalik

09

D

DE Anthrazit matt
GB Anthracite matt
FR Anthracite mat
NL Antraciet mat
IT Antracite opaco
ES Antracita mate
PT Antracite mate
DK Antracitgrå mat
NO Antrasitt matt
SE Antracitgrå matt
FI Antrasiitinharmaa matta
RU Антрацит матовый
PL Antracyt matowy
CZ Antracitová šedá matný
HU Antracit, fénytelen
SK Čierna uhľová matný
RO Antracit mat
BG Антрацит матово
SI Antracit mat
GR Γκρι ανθρακι ματ
TR Antrazit mat

91

E

DE Eisen metallic
GB Iron metallic
FR Fer métallique
NL IJzer metallic
IT Ferro metallico
ES Acero metálico
PT Aço metálico
DK Stål metallisk
NO Jern metallic
SE Stål metallic
FI Teräs metallinen
RU Сталь металик
PL Grafit metaliczny
CZ Ocelová metalizová
HU Acélmetál
SK Ocelová metaliza
RO Negru-strălucitor
BG Черно гланцово
SI Črna sijoča
GR Χρώμα σιδήρου μεταλλικό
TR Metalik metalik

07

F

DE Schwarz glänzend
GB Black gloss
FR Noir brillant
NL Zwart glanzend
IT Nero lucido
ES Negro brillante
PT Preto brilhante
DK Sort blank
NO Sort glansende
SE Svart blank
FI Musta kiiltävä
RU Чёрный глянцевый
PL Czarny błyszczący
CZ Černá lesklý
HU Fekete, fényes
SK Čierna lesklý
RO Negru-strălucitor
BG Черно гланцово
SI Črna sijoča
GR Μαύρο γυαλιστερό
TR Siyah parlak

50%

302

G

378

50%

DE Schwarz seidenmatt
GB Black silk matt
FR Noir satiné mat
NL Zwart zijdemat
IT Nero opaco satinato
ES Negro mate satinado
PT Preto mate sedoso
DK Sort silkematt
NO Sort silkematt
SE Svart sidenmatt
FI Musta silkkimatta
RU Чёрный шелковисто-матовый
PL Czarny jedwabście matowy
CZ Černá jemně matný
HU Fekete, fakóselymes
SK Čierna hodvábné matný
RO Negru satinat
BG Черно коприненоматово
SI Črna svilenomat
GR Μαύρο σατινέ
TR Siyah ipeksi mat

+

DE Dunkelgrau seidenmatt
GB Dark grey silk matt
FR Gris foncé satiné mat
NL Donkergrijs zijdemat
IT Grigio scuro opaco satinato
ES Gris oscuro mate satinado
PT Cinza escuro mate sedoso
DK Mørkegrå silkematt
NO Mørk grå silkematt
SE Mörkgrå sidenmatt
FI Tummanharmaa silkkimatta
RU Тёмно-серый шелковисто-матовый
PL Ciemnoszary jedwabście matowy
CZ Tmavá šedá jemně matný
HU Sötétszürke, fakóselymes
SK Tmavo sivá hodvábné matný
RO Gri-inchis satinat
BG Тъмносиво коприненоматово
SI Temno-siva svilenomat
GR Γκρι σκούρο σατινέ
TR Koyu gri ipeksi mat

50%

94

H

90

50%

DE Gold metallic
GB Gold metallic
FR Or métallique
NL Goud metallic
IT Oro metallico
ES Oro metálico
PT Ouro metálico
DK Guld metallisk
NO Gull metallic
SE Guld metallic
FI Kultra metallinen
RU Золото металик
PL Złoty metaliczny
CZ Zlatá metalizová
HU Aranyetál
SK Zlatá metaliza
RO Auriu metalic
BG Злато металик
SI Zlata kovinska
GR Χρυσάφι μεταλλικό
TR Altın rengi metalik

+

DE Silber metallic
GB Silver metallic
FR Argent métallique
NL Zilver metallic
IT Argento metallico
ES Plata metálico
PT Prata metálico
DK Sølv metallisk
NO Sølv metallic
SE Silver metallic
FI Hopea metallinen
RU Серебрянный металик
PL Srebrny metaliczny
CZ Stříbrná metalizová
HU Ezüstmetál
SK Strieborná metaliza
RO Argintiu metalic
BG Сребро металик
SI Srebrna kovinska
GR Ασημί μεταλλικό
TR Gümüş rengi metalik

301

I

DE Weiß seidenmatt
GB White silk matt
FR Blanc satiné mat
NL Wit zijdemat
IT Bianco opaco satinato
ES Blanco mate satinado
PT Branco mate sedoso
DK Hvid silkematt
NO Hvit silkematt
SE Vit sidenmatt
FI Valkoinen silkkimatta
RU Белый шелковисто-матовый
PL Biały jedwabście matowy
CZ Bílá jemně matný
HU Fehér, fakóselymes
SK Biela hodvábné matný
RO Alb satinat
BG Бяло коприненоматово
SI Bela svilenomat
GR Ασπρο σατινέ
TR Beyaz ipeksi mat

12

J

DE Gelb glänzend
GB Yellow gloss
FR Jaune brillant
NL Geel glanzend
IT Giallo lucido
ES Amarillo brillante
PT Amarelo brilhante
DK Gul blank
NO Gul glansende
SE Gul blank
FI Keltainen kiiltävä
RU Жёлтый глянцевый
PL Żółty błyszczący
CZ Žlutá lesklý
HU Sárga, fényes
SK Žltá lesklý
RO Galben strălucitor
BG Жълто гланцово
SI Rumena sijoča
GR Κίτρινο γυαλιστερό
TR Sarı parlak

90%

51

K

91

10%

DE Ultramarinblau glänzend
 GB Ultramarine blue gloss
 FR Bleu outremer brillant
 NL Ultramarineblauw glanzend
 IT Blu oltremare lucido
 ES Azul marino brillante
 PT Azul marinho brilhante
 DK Ultra marineblå blank
 NO Ultra marineblå glansende
 SE Ultramarinblå blank
 FI Ultramariini kiiltävä
 RU Ультрамарин гляцевый
 PL Ultramaryna błyszcząca
 CZ Ultramarinová modř lesklý
 HU Ultramarin kék, fényes
 SK Ultramarin modrá lesklý
 RO Albastru ultramarin strălucitor
 BG Ультрамарин гланцово
 SI Ultramarinska-modra sijoča
 GR Μπλε βαθύ γυαλιστερό
 TR Lacivert parlak

+

DE Eisen metallic
 GB Iron metallic
 FR Fer métallique
 NL IJzer metallic
 IT Ferro metallico
 ES Acero metálico
 PT Aço metálico
 DK Stål metallisk
 NO Jern metallic
 SE Stål metallic
 FI Teräs metallinen
 RU Сталь металли
 PL Grafit metaliczny
 CZ Ocelová metalizový
 HU Acélmetál
 SK Ocelová metaliza
 RO Fier metalic
 BG Желязо металик
 SI Železna kovinska
 GR Χρώμα σιδήρου μεταλλικό
 TR Metalik metalik

78

L

DE Panzergrau matt
 GB Tank grey matt
 FR Gris blindé mat
 NL Tankgrijs mat
 IT Grigio carro armato opaco
 ES Gris tanque mate
 PT Cinza tanque mate
 DK Pansergrå mat
 NO Pansergrå matt
 SE Pansargrå matt
 FI Tankinharmaa matta
 RU Серый танк матовый
 PL Szary głęboki matowy
 CZ Pancéřová šedá matný
 HU Páncélszürke, fénytelen
 SK Tanková sivá matný
 RO Gri-tanc mat
 BG Танковосиво матово
 SI Tankovsko-siva mat
 GR Μολυβί σκούρο ματ
 TR Tank yeşili mat

730

M

DE Orange klar
 GB Orange clear
 FR Orange clair
 NL Oranje helder
 IT Arancio chiaro
 ES Naranja claro
 PT Laranja transparente
 DK Orange klar
 NO Oransje klar
 SE Orange klar
 FI Oranssi kirkas
 RU Оранжевый прозрачный
 PL Pomarańczowy przezroczysty
 CZ Oranžová bezbarvý
 HU Narancs, világos
 SK Oranžová číry
 RO Oranj curat
 BG Оранжево бистро
 SI Oranžna čista
 GR Πορτοκαλί διάφανο
 TR Turuncu canlı

382

N

DE Holzbraun seidenmatt
 GB Wood brown silk matt
 FR Brun bois satiné mat
 NL Houtbruin zijdemat
 IT Marrone legno opaco satinato
 ES Marrón madera mate satinado
 PT Castanho madeira mate sedoso
 DK Træbrun silkematt
 NO Trebrun silkematt
 SE Tråbrun sidenmatt
 FI Puunruskea silkkimatta
 RU Древесно-коричневый шелковисто-матовый
 PL Brązowy w odcieniu drewna jedwabście matowy
 CZ Dřevěná hnědá jemně matný
 HU Fa barna, fakóselymes
 SK Drevná hnedá hodvábné matný
 RO Maro lemnos satinat
 BG Дървеснокафяво коприненоматово
 SI Lesno-rjava svilenomat
 GR Καφέ ανοιχτό σατινέ
 TR Ahşap rengi ipeksi mat

70%

30

O

330

30%

DE Orange glänzend
 GB Orange gloss
 FR Orange brillant
 NL Oranje glanzend
 IT Arancio lucido
 ES Naranja brillante
 PT Laranja brilhante
 DK Orange blank
 NO Oransje glansende
 SE Orange blank
 FI Oranssi kiiltävä
 RU Оранжевый гляцевый
 PL Pomarańczowy błyszcząca
 CZ Oranžová lesklý
 HU Narancs, fényes
 SK Oranžová lesklý
 RO Oranj strălucitor
 BG Оранжево гланцово
 SI Oranžna sijoča
 GR Πορτοκαλί γυαλιστερό
 TR Turuncu parlak

+

DE Feuerrot seidenmatt
 GB Fiery red silk matt
 FR Rouge feu satiné mat
 NL Vuurood zijdemat
 IT Rosso fuoco opaco satinato
 ES Rojo fuego mate satinado
 PT Vermelho fogo mate sedoso
 DK Ildrød silkematt
 NO Ildrød silkematt
 SE Eldröd sidenmatt
 FI Tulenpunainen silkkimatta
 RU Огненно-красный шелковисто-матовый
 PL Ognistoczerwony jedwabście matowy
 CZ Ohnivě červená jemně matný
 HU Túzpiros, fakóselymes
 SK Ohnivá červená hodvábné matný
 RO Roșu aprins satinat
 BG Огненочервено коприненоматово
 SI Ognjeno-rdeča svilenomat
 GR Κόκκινο φωτιάς σατινέ
 TR Alev kırmızı ipeksi mat

02

P

DE Farblos matt
 GB Clear matt
 FR Incolore mat
 NL Kleurloos mat
 IT Incolore opaco
 ES Incoloro mate
 PT Verniz mate
 DK Klarlak mat
 NO Klar matt
 SE Klarlack matt
 FI Väritön matta
 RU Бесцветный матовый
 PL Przezroczysty matowy
 CZ Bezbarvá matný
 HU Szintelen, fénytelen
 SK Prieľadný matný
 RO Transparent mat
 BG Безцветно матово
 SI Brezbarvna mat
 GR Διάφανο ματ
 TR Renksiz mat

76

Q

DE Hellgrau matt
 GB Light grey matt
 FR Gris clair mat
 NL Lichtgrijs mat
 IT Grigio chiaro opaco
 ES Gris claro mate
 PT Cinza claro mate
 DK Lysegrå mat
 NO Lysegrå matt
 SE Ljusgrå matt
 FI Vaaleanharmaa matta
 RU Светло-серый матовый
 PL Jasnoszary matowy
 CZ Světlá šedivá matný
 HU Világosszürke, fénytelen
 SK Svetlo sivá matný
 RO Gri-deschis mat
 BG Светлосиво матово
 SI Svetlo-siva mat
 GR Γκρι ανοιχτό ματ
 TR Açık gri mat

83

R

DE Rost matt
 GB Rust matt
 FR Rouille mat
 NL Roest mat
 IT Ruggine opaco
 ES óxido mate
 PT Ferrugem mate
 DK Rust mat
 NO Rust matt
 SE Rost matt
 FI Ruoste matta
 RU Ржавый матовый
 PL Rdzawy matowy
 CZ Rezavá matný
 HU Rozsdaszín, fénytelen
 SK Hrdzavá matný
 RO Ruginiu mat
 BG Ръжда матово
 SI Rjasta mat
 GR Χρώμα σκουριάς ματ
 TR Pas rengi mat

77

S

DE Staubgrau matt
 GB Dusty grey matt
 FR Gris poussière mat
 NL Stofgrijs mat
 IT Grigio polvere opaco
 ES Gris polvo mate
 PT Cinza pó mate
 DK Støvet grå mat
 NO Støvgrå matt
 SE Dammgrå matt
 FI Tomunharmaa matta
 RU Серая пыль матовый
 PL Szary stłowy matowy
 CZ Prachová šed matný
 HU Porszürke, fénytelen
 SK Prachovo sivá matný
 RO Gri prăfuit mat
 BG Прашносиво матово
 SI Prašno-siva mat
 GR Σταχτί ματ
 TR Duman grişi mat

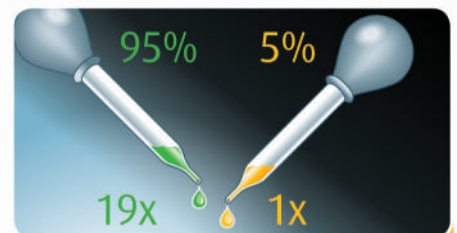

DE Beispiel: mischen
 GB Example: mixing
 FR Exemple: mélanger
 NL Voorbeeld: mengen
 IT Esempio: mescolare
 ES Ejemplo: mezcla
 PT Exemplo: misturar
 DK Eksempel: blanding
 NO Eksempel: blanda
 SE Exempel: blanda
 FI Esimerkki: sekoittaminen

RU Пример: смешивание
 PL Przykład: mieszanie
 CZ Příklad: míchání
 HU Példa: keverés
 SK Příklad: miešanie
 NO Exemplet: amestecare
 BG Пример: смесване
 SI Primer: mešanje
 GR Παράδειγμα: ανάμειξη
 TR Örnek: karıştırma

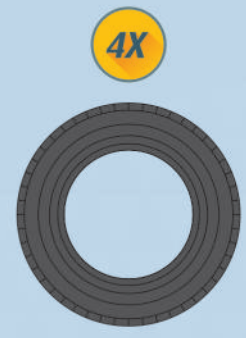
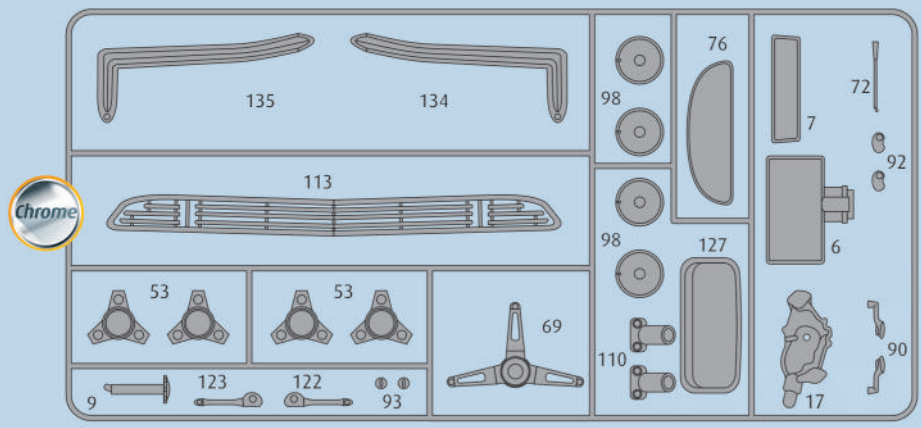
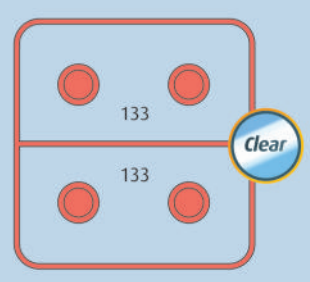
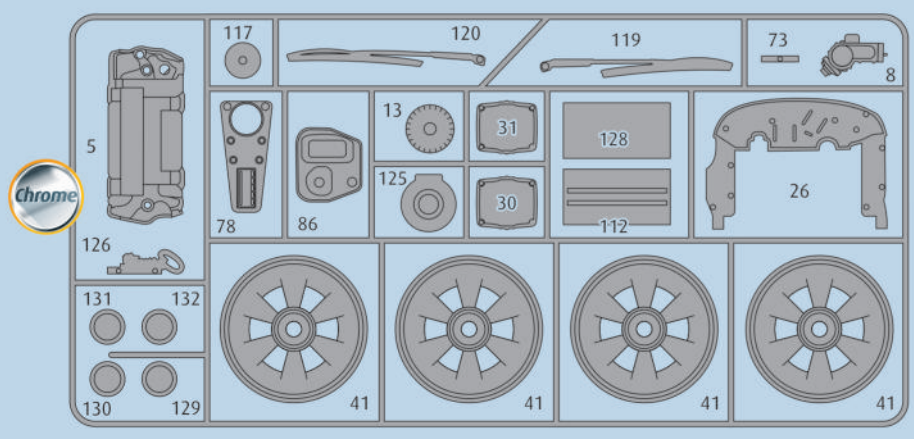
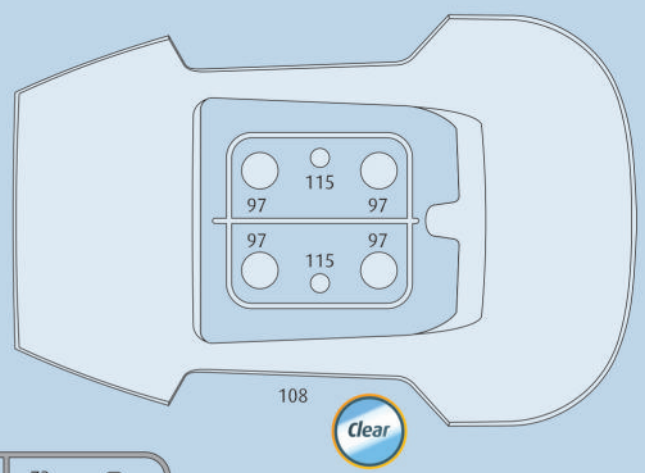
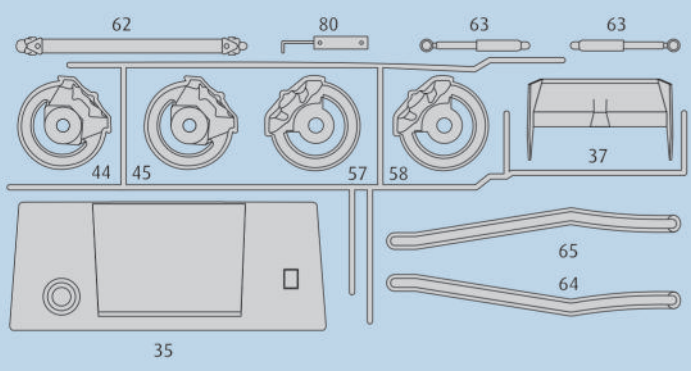

Ersatzteile benötigt?

Kein Problem. Einfach den Revell-Service mit Angabe von Artikel- und Teilenummer kontaktieren. Entweder unter service@revell.de oder Revell GmbH, Abteilung X, Henschelstr. 20-30, 32257 Bünde.*

*Wir bitten um Verständnis, dass eine Gewährleistung nur bei aktuellen Artikeln, die im Zeitraum der letzten 24 Monate erworben wurden, übernommen werden kann. Mit der Ersatzteil-Bestellung können Kosten z.B. für Verpackung und Versand entstehen. Ob diese Kosten anfallen wird im Vorfeld schriftlich durch unseren Service mitgeteilt. Das Angebot kann dann angenommen oder abgelehnt werden. Unfrei eingesandte Ersatzteil-Bestellungen werden von uns nicht angenommen! Dieser Direktservice gilt für die Länder Deutschland, Benelux, Österreich, Frankreich, Großbritannien. Ersatzteil-Bestellungen aus den übrigen Ländern werden über die jeweiligen Distributeure abgewickelt. Bitte kontaktieren Sie Ihren Händler.

Besoin de pièces de rechange ?

Il vous suffit de contacter le service Revell et d'indiquer la référence de l'article et de la pièce. Soit en écrivant par mail à france@revell.de (uniquement pour la France) ou par courrier à Revell GmbH, Département X, Henschelstr. 20-30, D-32257 Bünde.*

*La garantie s'applique pour les articles présents au catalogue et achetés au cours des 24 derniers mois. Merci de votre compréhension. La commande de pièces de rechange peut donner lieu à des frais supplémentaires, par ex. pour l'emballage et le port. Notre service client vous en informera au préalable par écrit. Vous pourrez accepter ou refuser le devis. Nous n'acceptons pas les commandes de pièces de rechange envoyées sans affranchissement ! Ce service direct est valable pour les pays suivants : Allemagne, Benelux, Autriche, France, Grande-Bretagne. Les commandes de pièces en provenance d'autres pays sont traitées par les distributeurs correspondants. Veuillez contacter votre revendeur.

Need spare parts?

No problem. Contact Revell Service with the item number and part numbers you need: service@revell.de or Revell GmbH, Unit 10, Old Airfield Industrial Estate, Cheddington Lane, Tring, Herts, HP23 4QR, Great Britain.*

*We request your understanding that a warranty can only be accepted for current articles which have been purchased in the last 24 months. Orders for spare parts may also be subject to costs for packaging and shipping. You will be notified in advance by our Service department if such costs are incurred. The offer can then be accepted or rejected. We will not be able to process any postal requests unless correct postage has been applied to mailing! This direct service applies to the countries: Germany, Benelux, Austria, France, and the United Kingdom. Spare part orders from other countries are processed by the local distributors. Please contact your dealer.

Hebt u reserveonderdelen nodig?

Geen probleem! Neem eenvoudig contact op met de klantenservice van Revell en geef ons het artikel- en onderdeelnummer door. U kunt ons bereiken op service@revell.de of per post: Revell GmbH, Afdeling X, Henschelstr. 20-30, 32257 Bünde.*

*Wij vragen uw begrip voor de omstandigheid, dat er alleen garantie kan worden geboden voor actuele artikelen, die in de afgelopen 24 maanden zijn gekocht. Met het bestellen van reserveonderdelen kunnen kosten gemoeid zijn, bijv. voor verpakking en verzending. U wordt vooraf schriftelijk door onze klantenservice op de hoogte gesteld als er kosten zouden ontstaan. Het aanbod kan dan worden aangenomen of afgewezen. Wij nemen geen ongefrankeerde bestellingen van reserveonderdelen aan! Deze rechtstreekse service wordt verleend in de landen Duitsland, de Benelux, Oostenrijk, Frankrijk en Groot-Brittannië. Bestellingen van reserveonderdelen in de overige landen worden afgewikkeld via de betreffende distributeurs. Neem hiervoor contact op met uw verkoper.

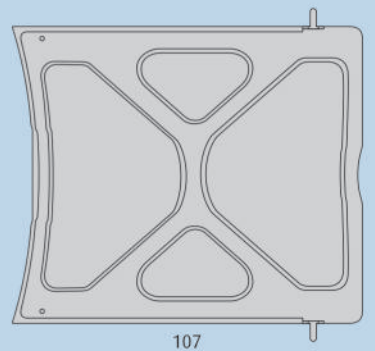
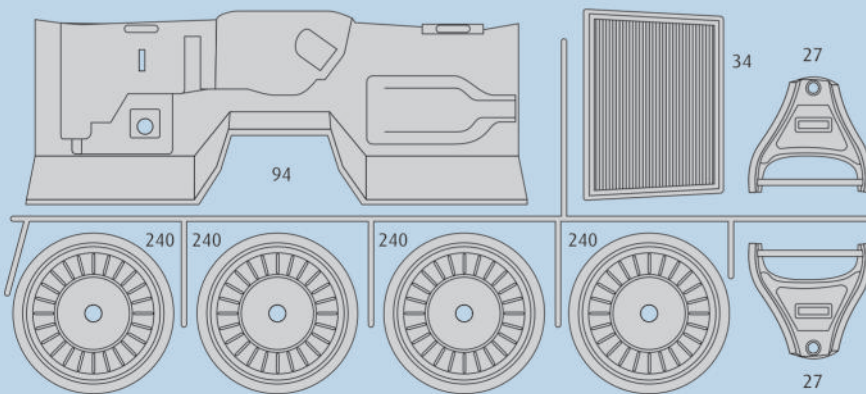
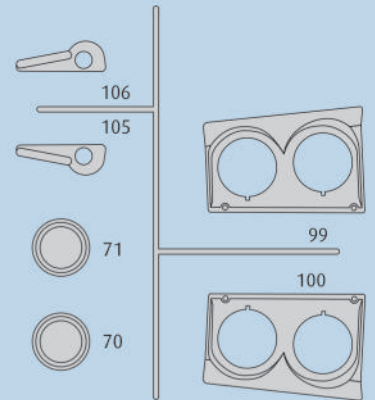
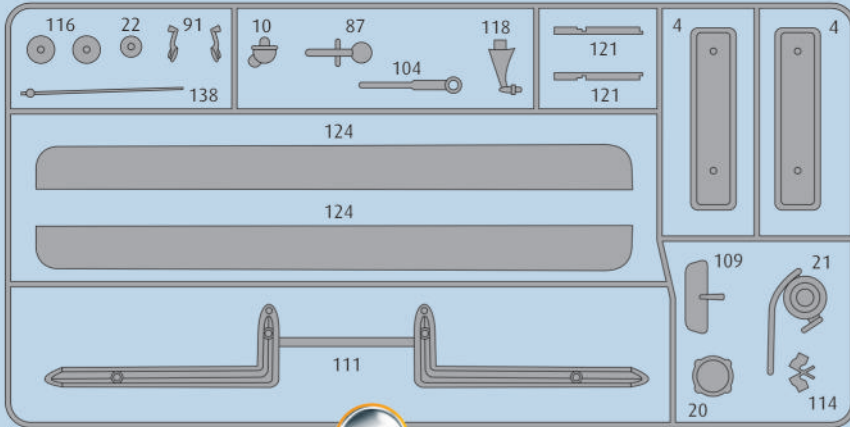
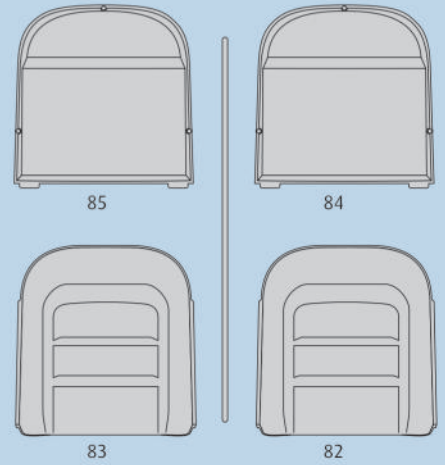
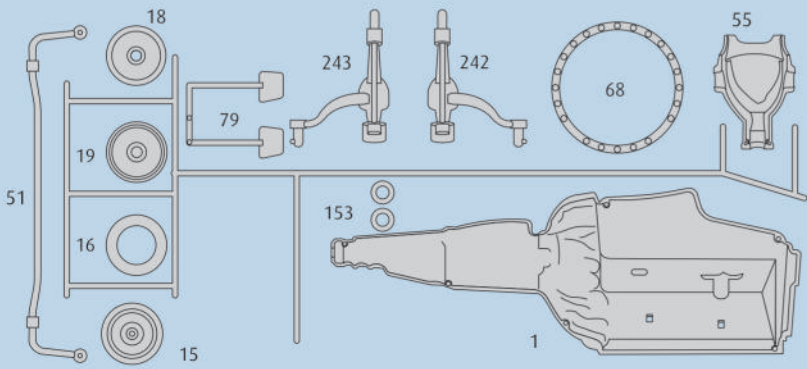
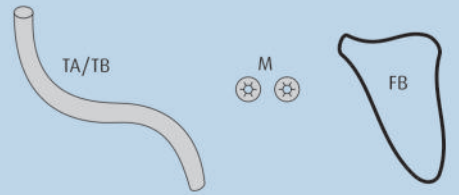
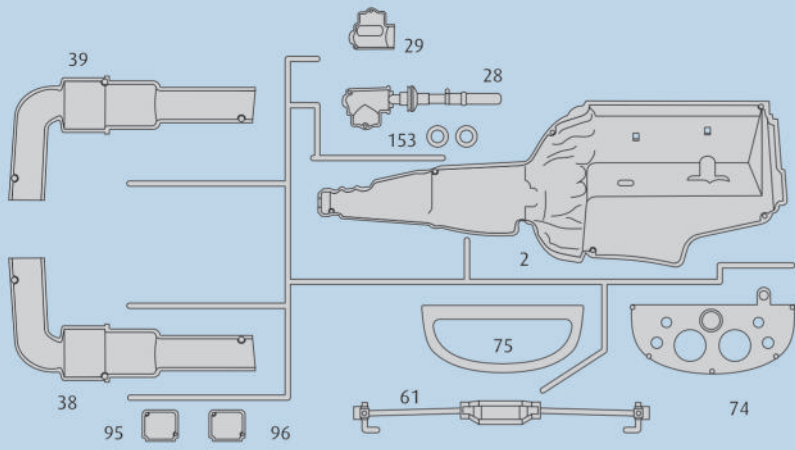

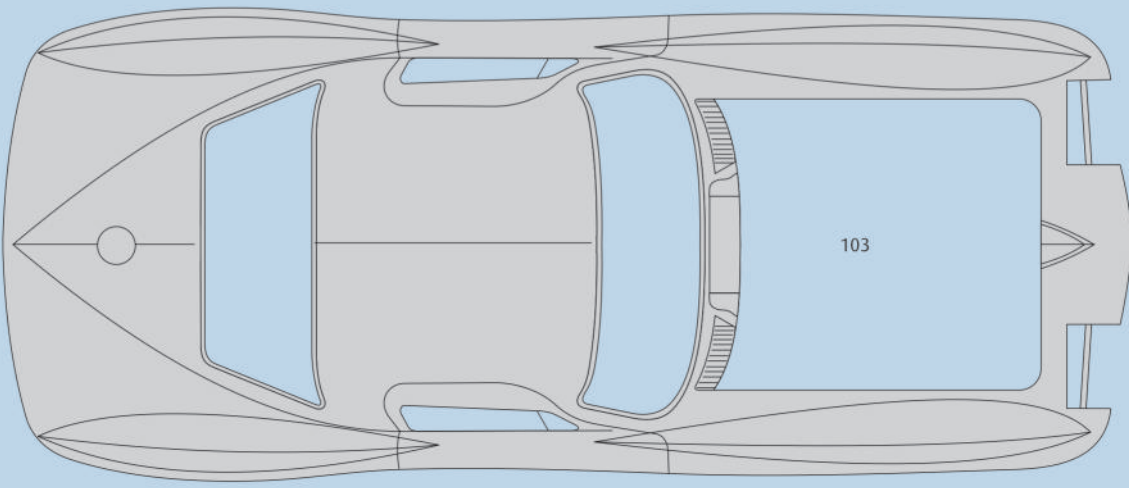
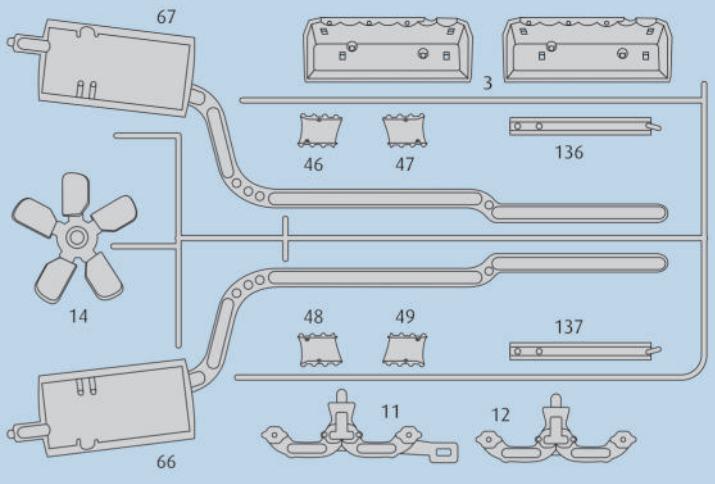
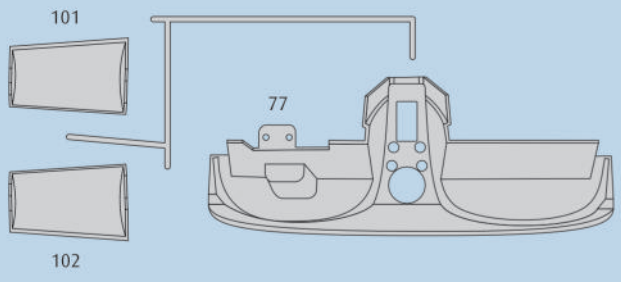
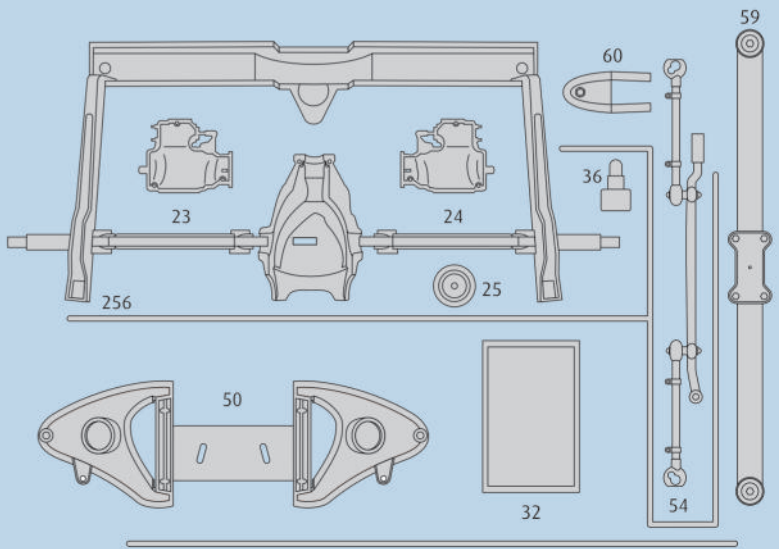
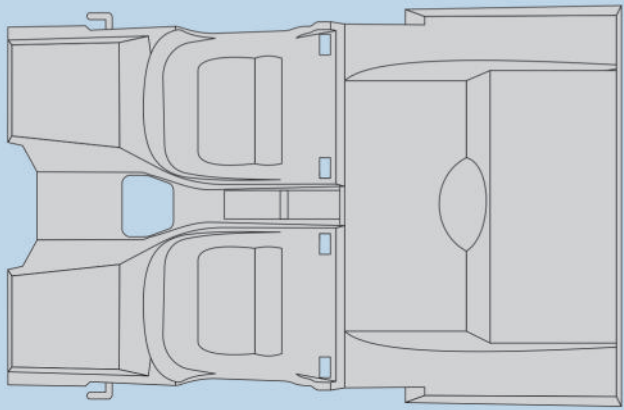
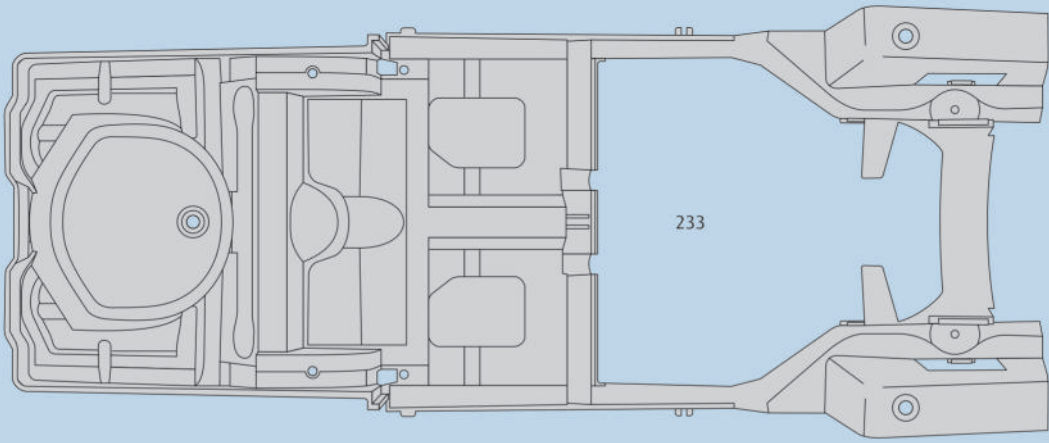

1

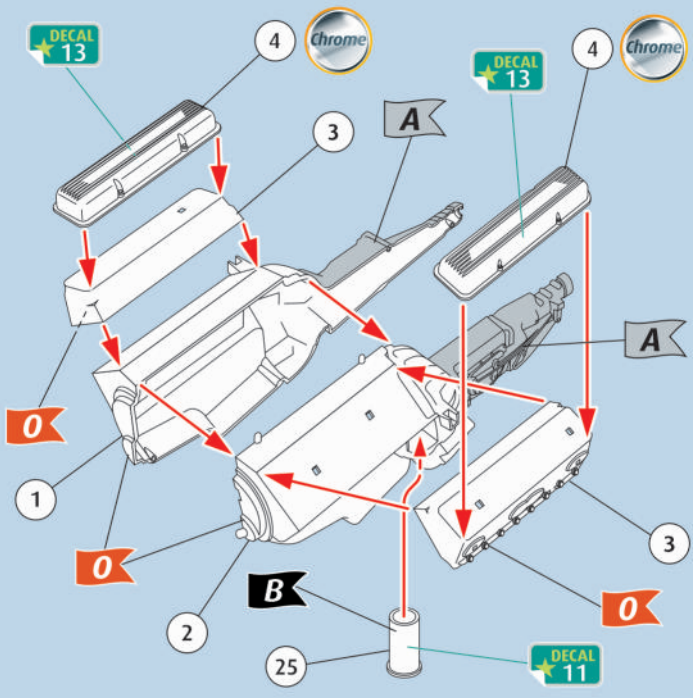

2

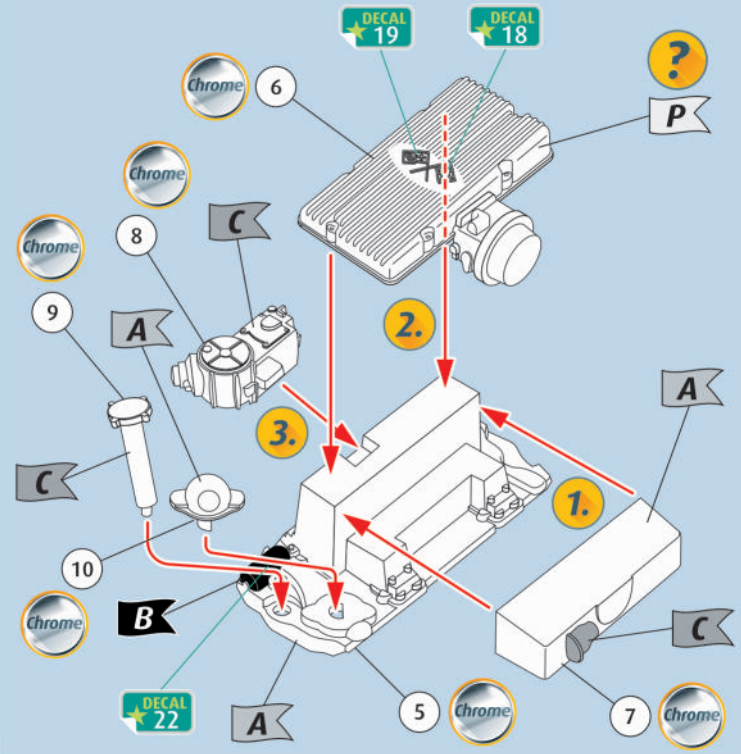

3

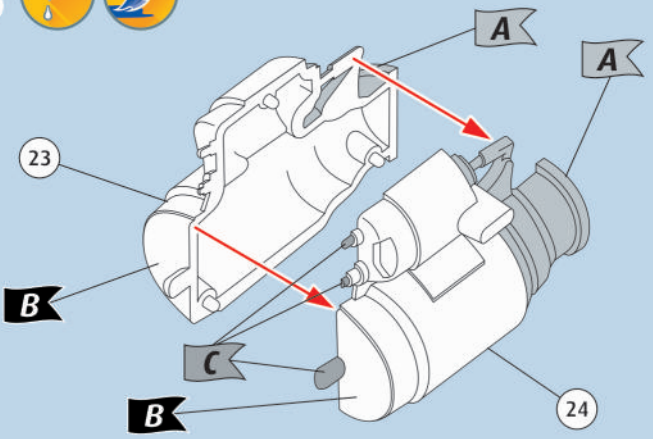

4

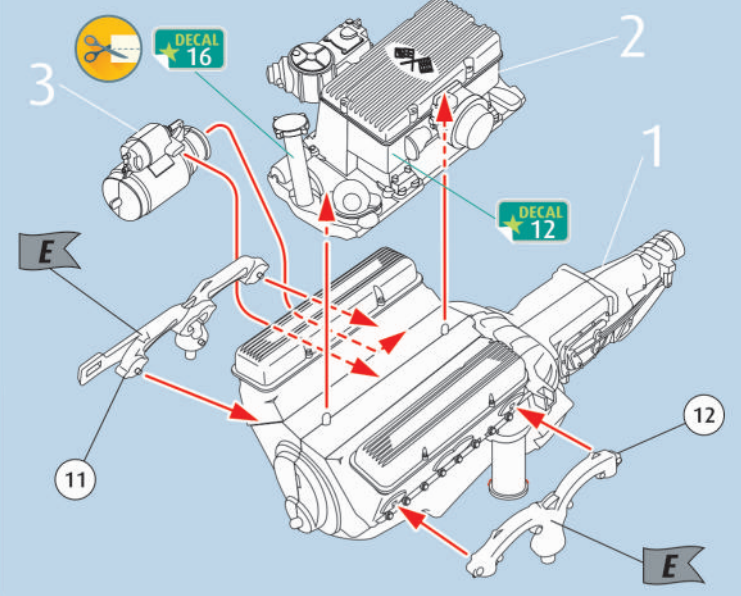

5

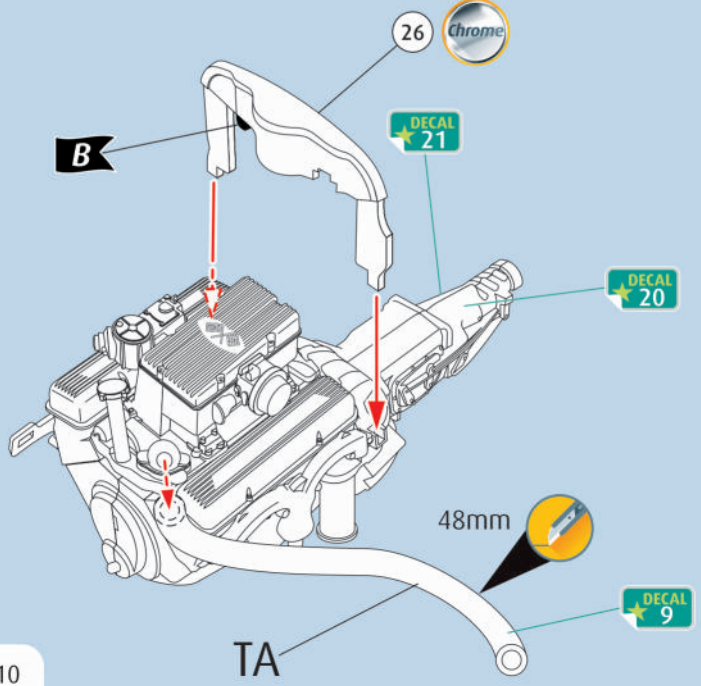

6

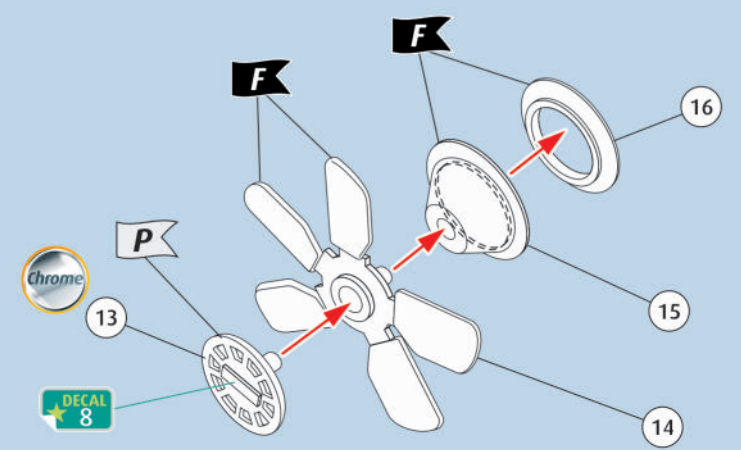

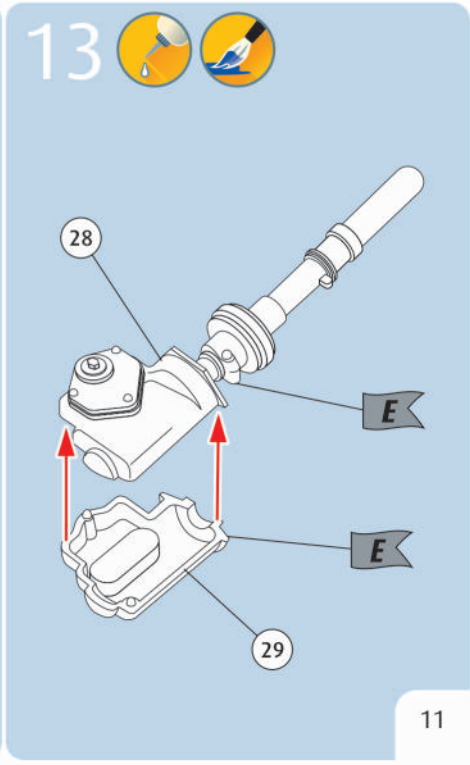
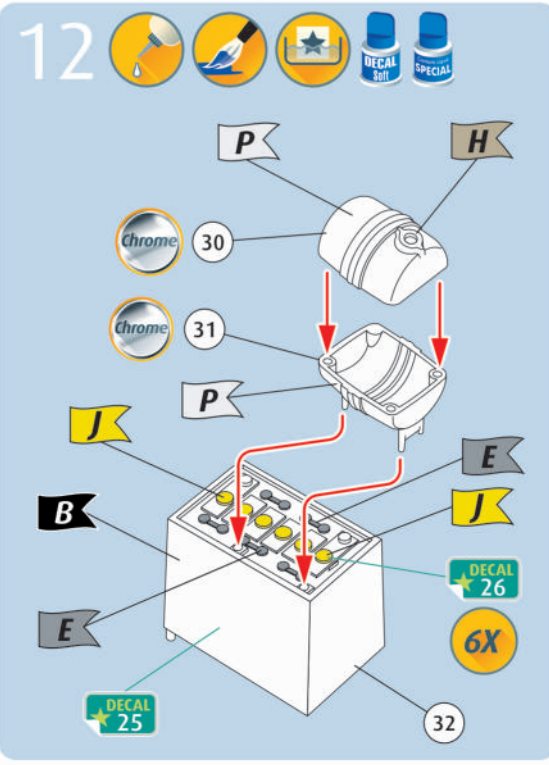
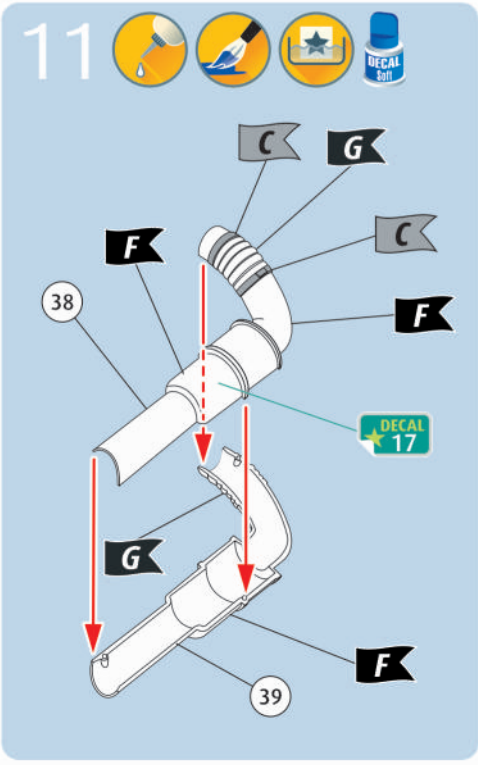
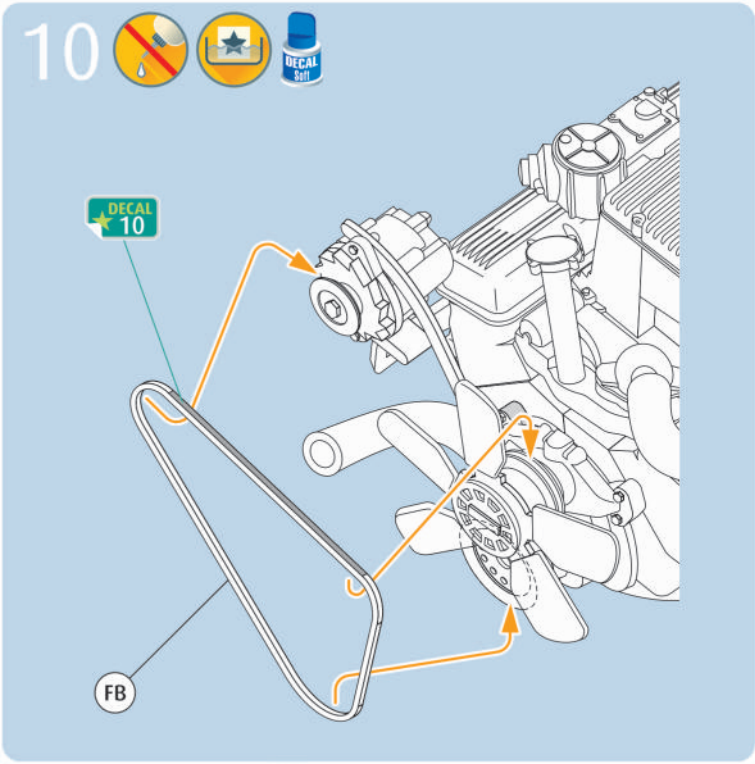
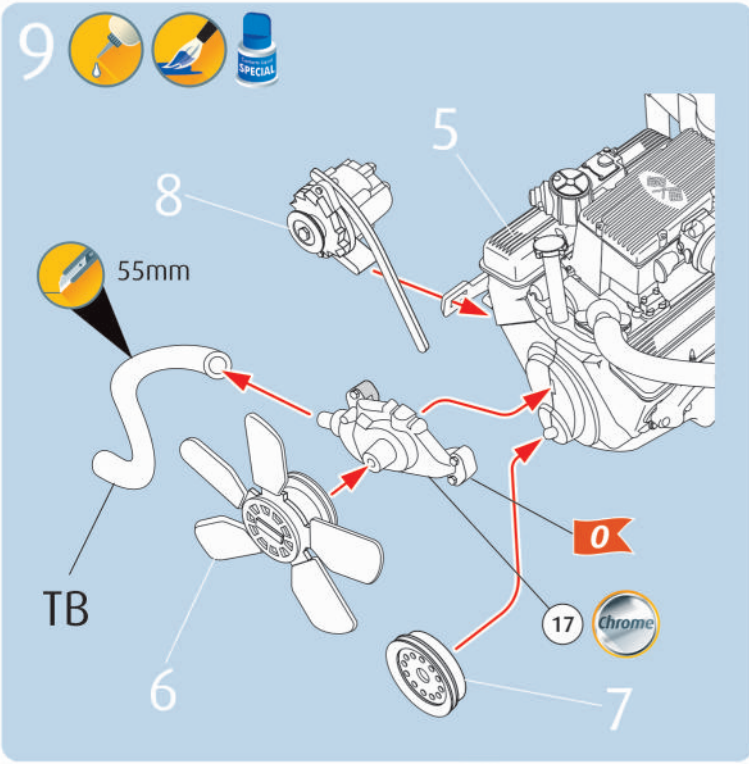
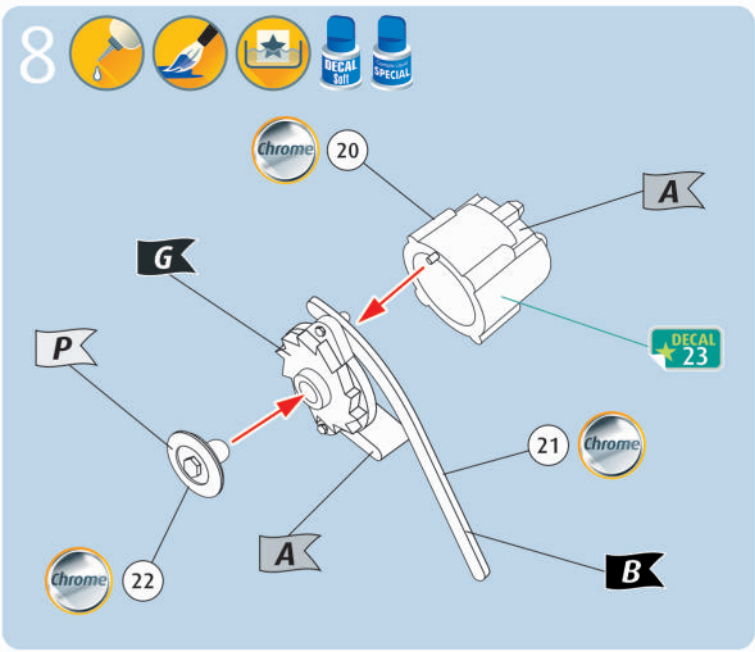
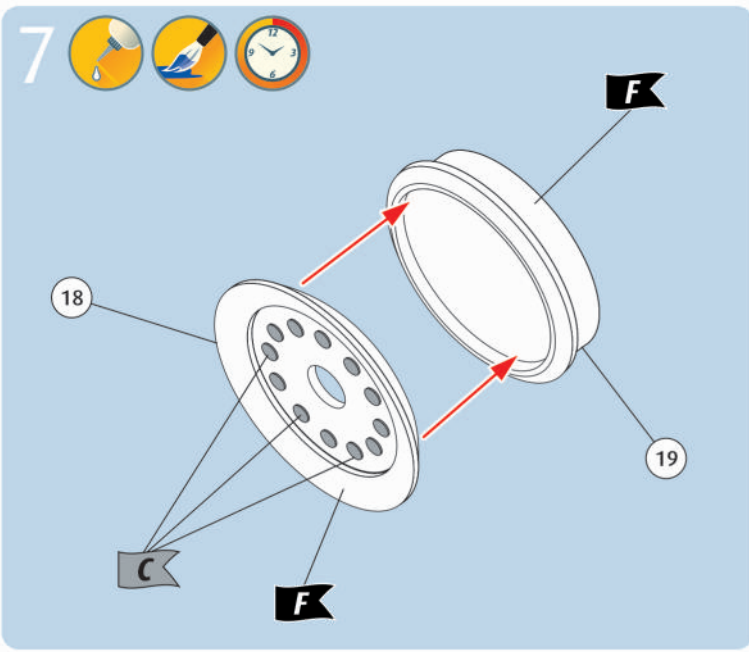

14

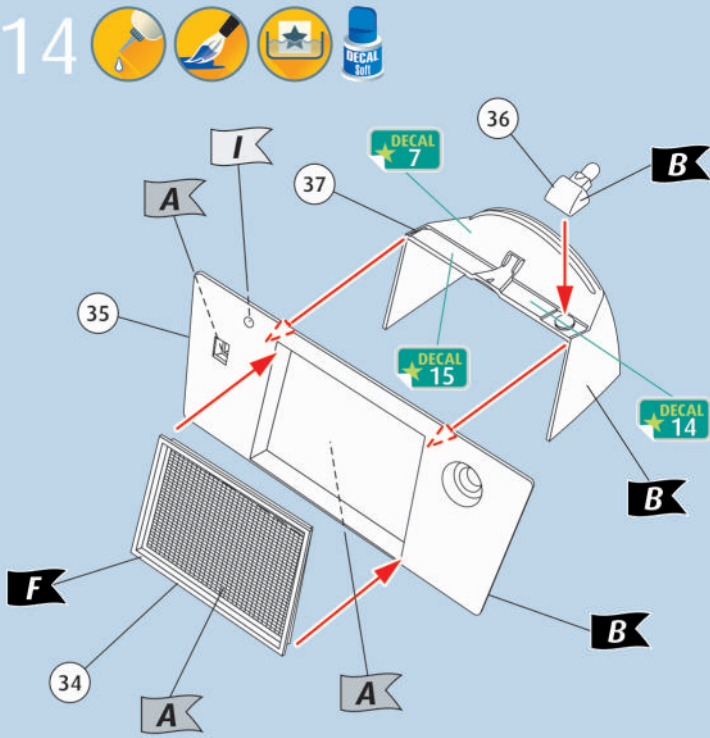

15

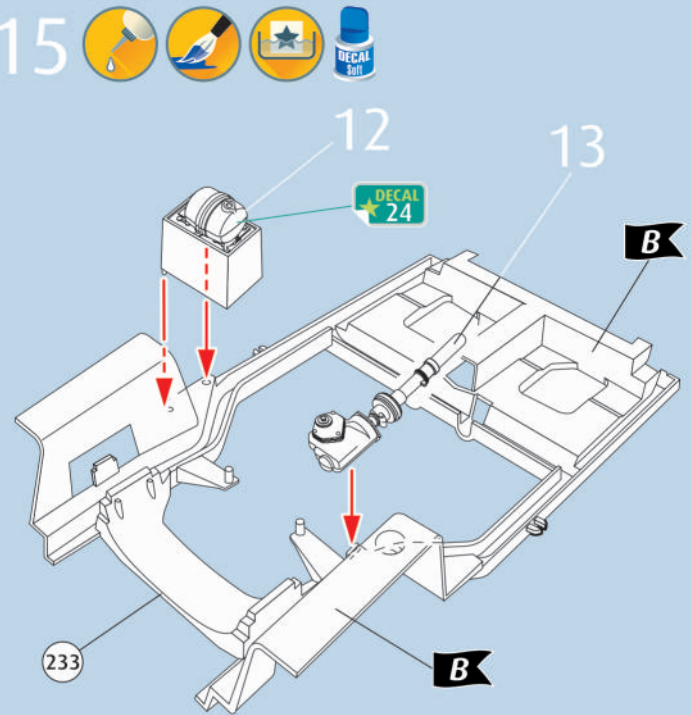

16

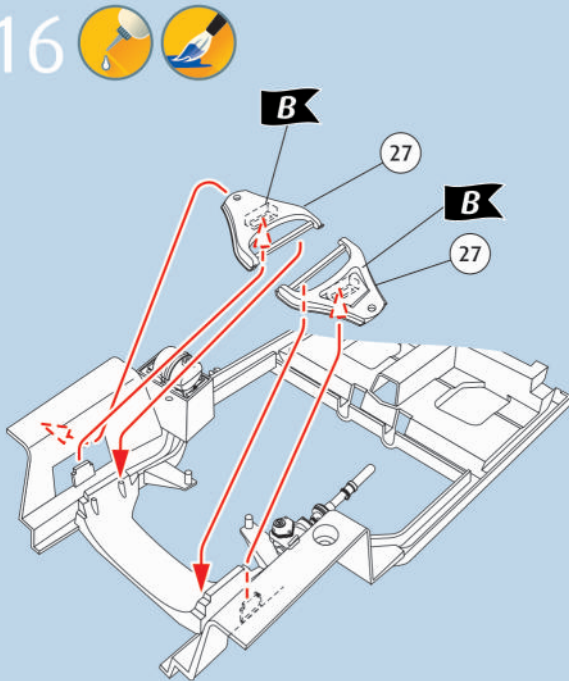

17

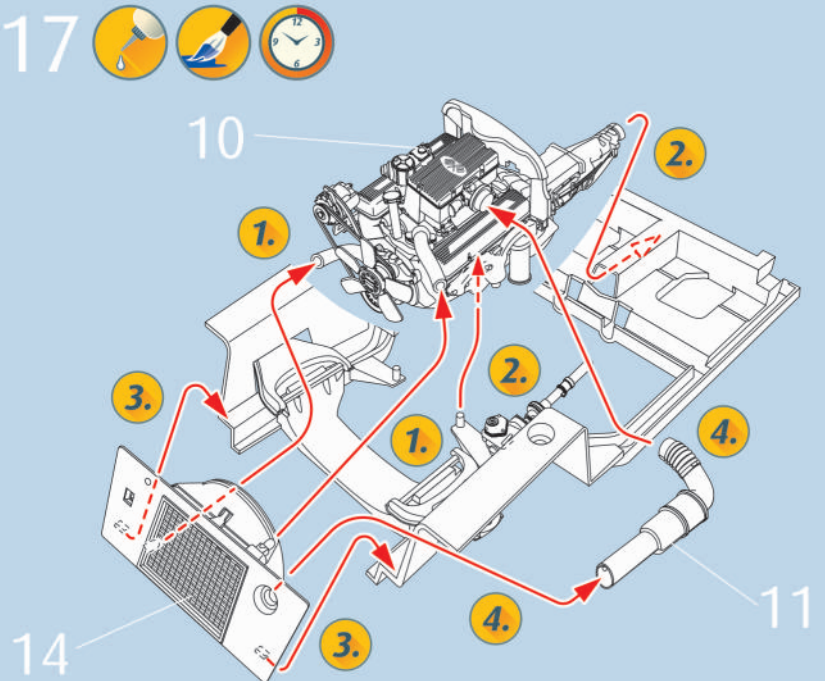

18L

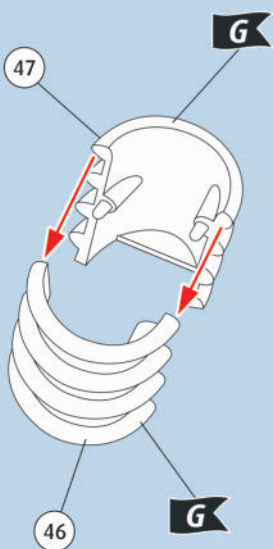

18R

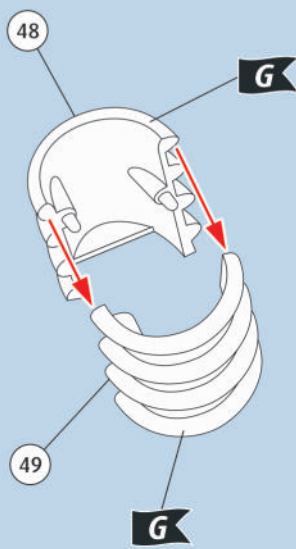

19

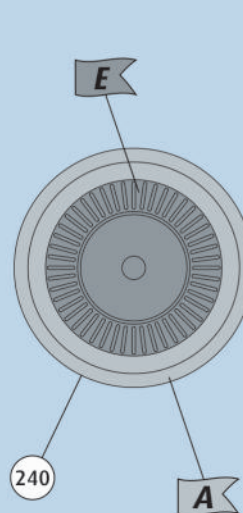

20

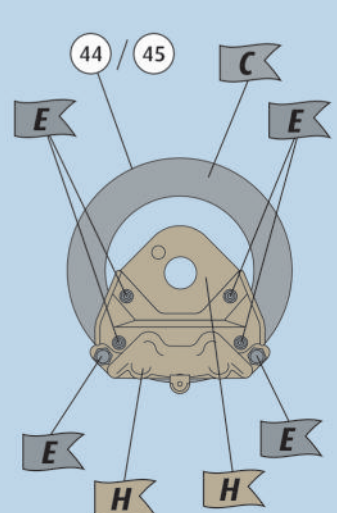

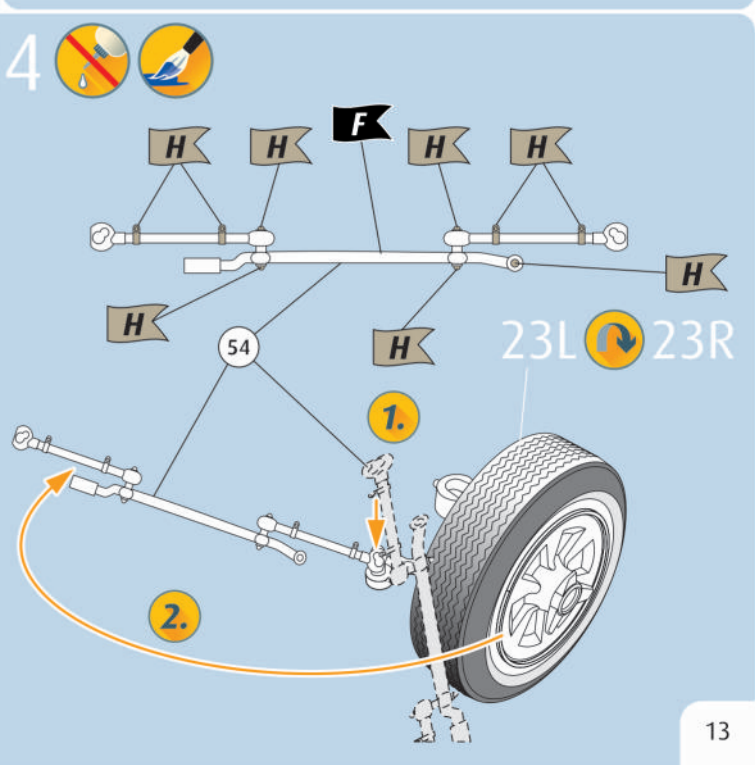
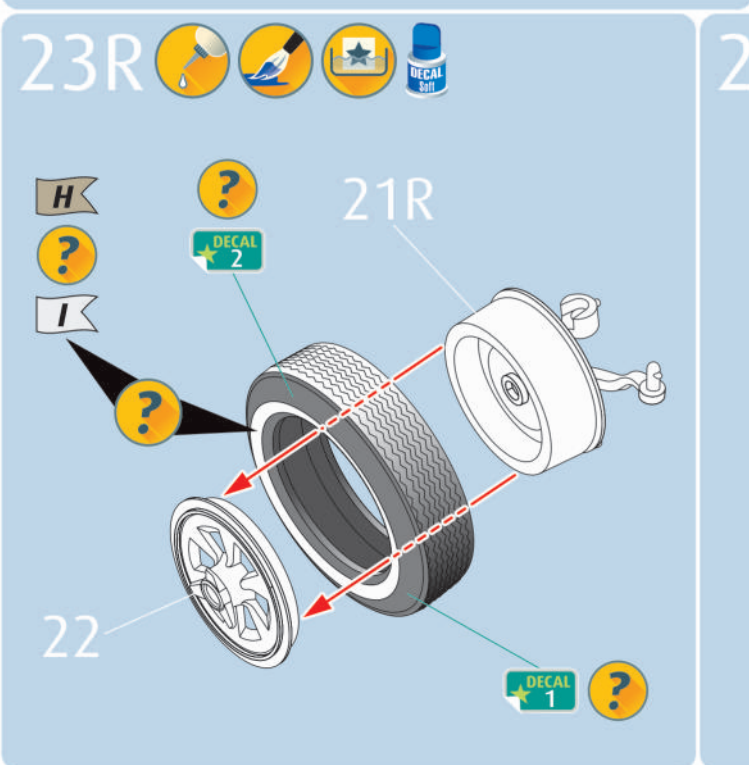
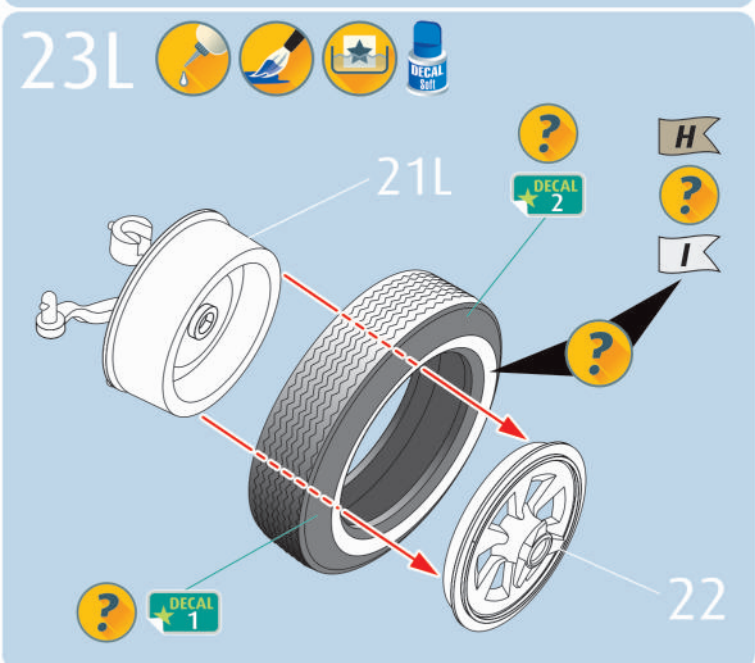
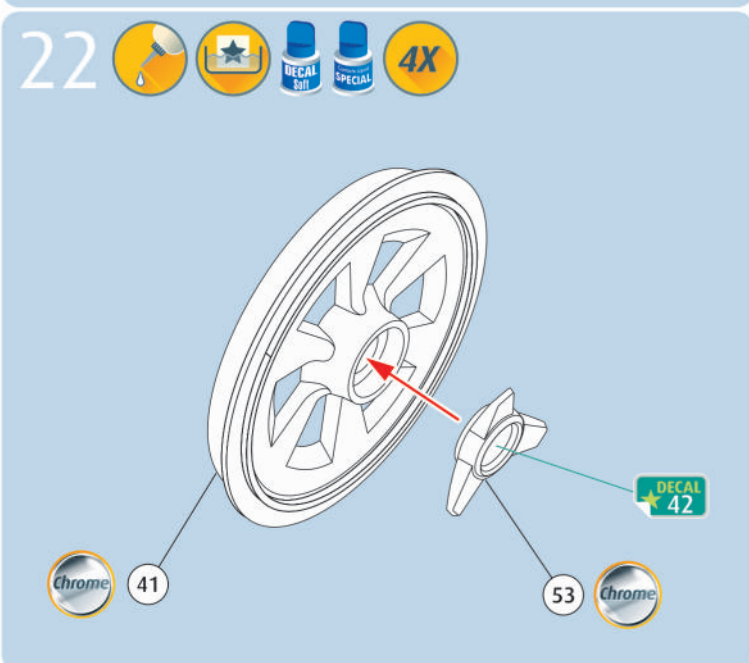
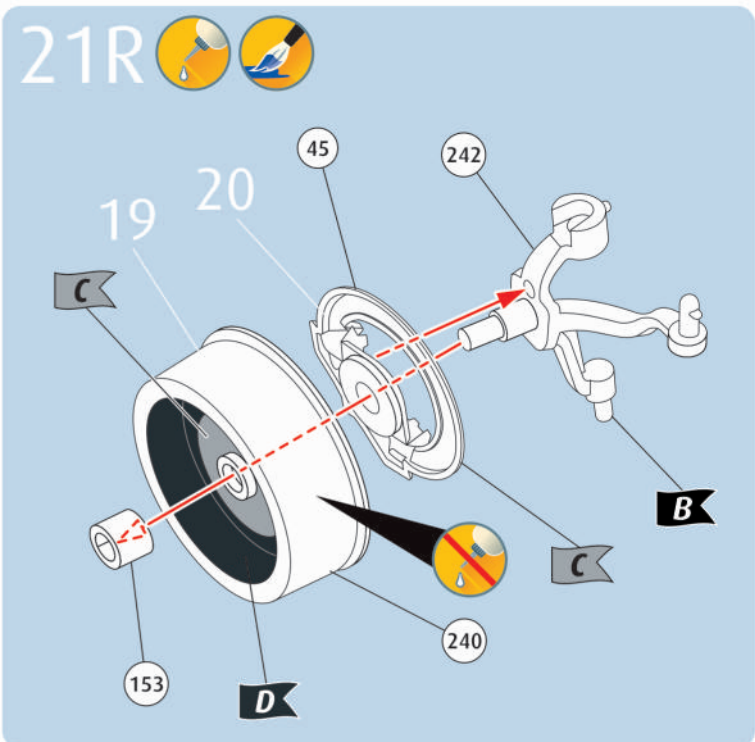
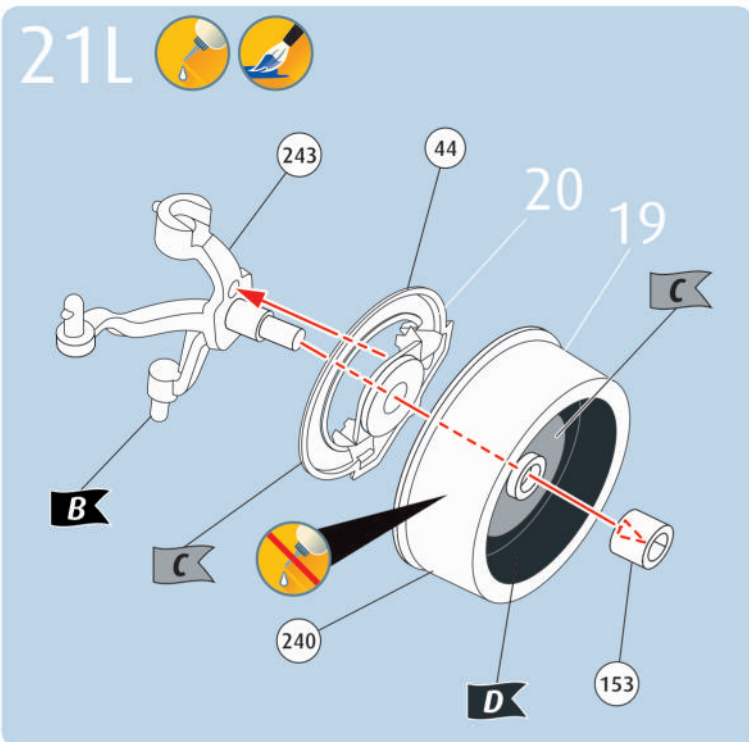

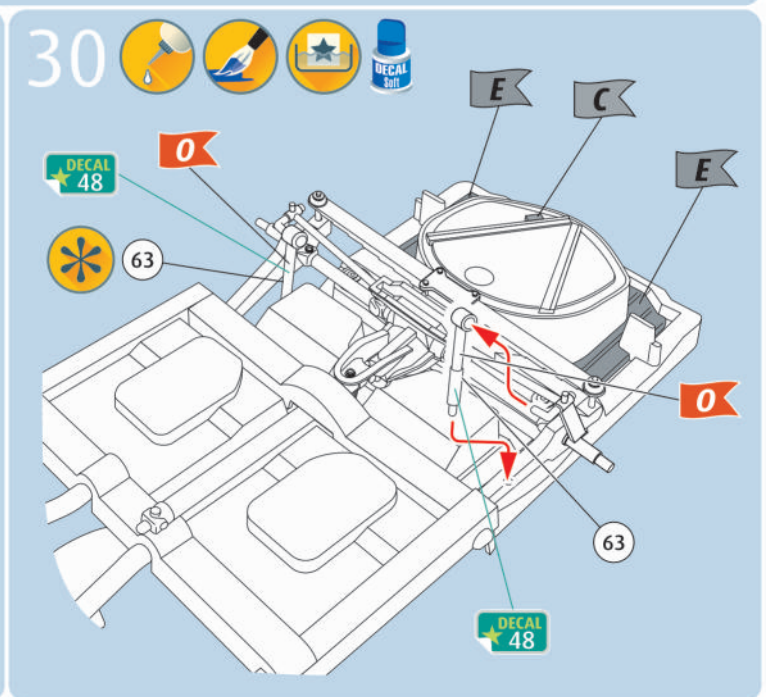
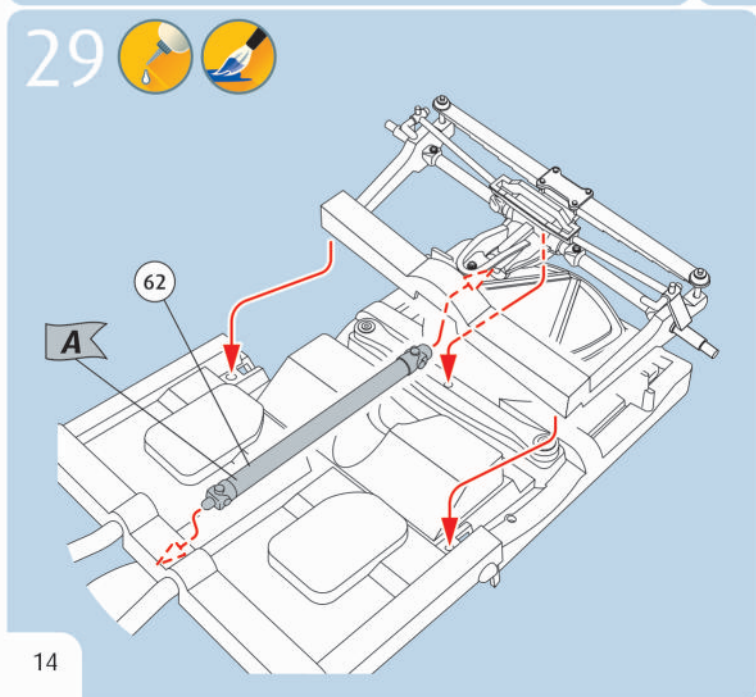
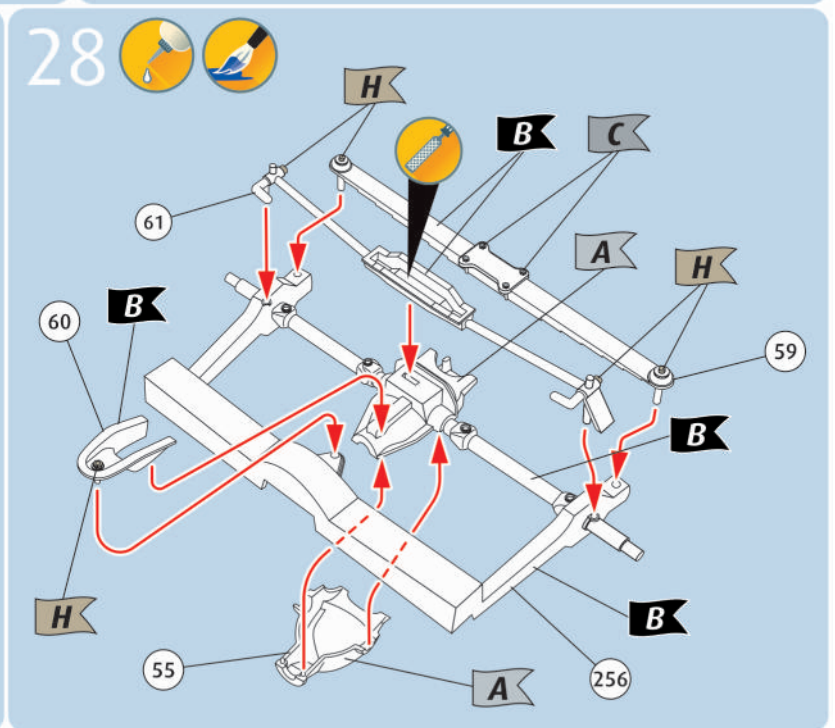
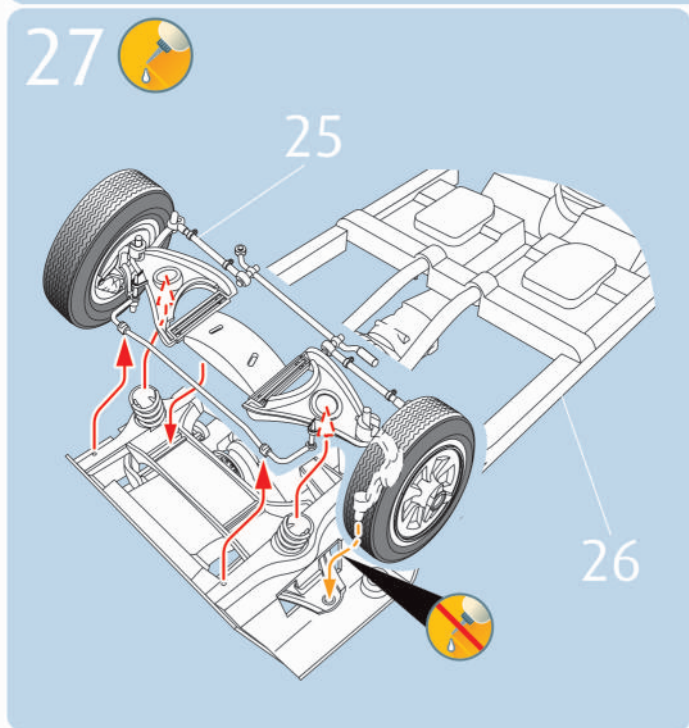
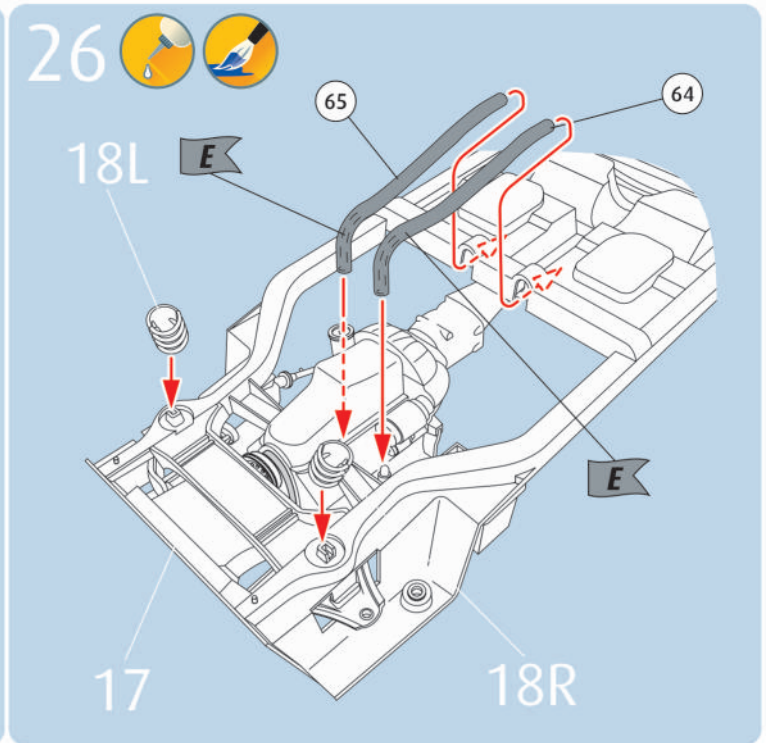
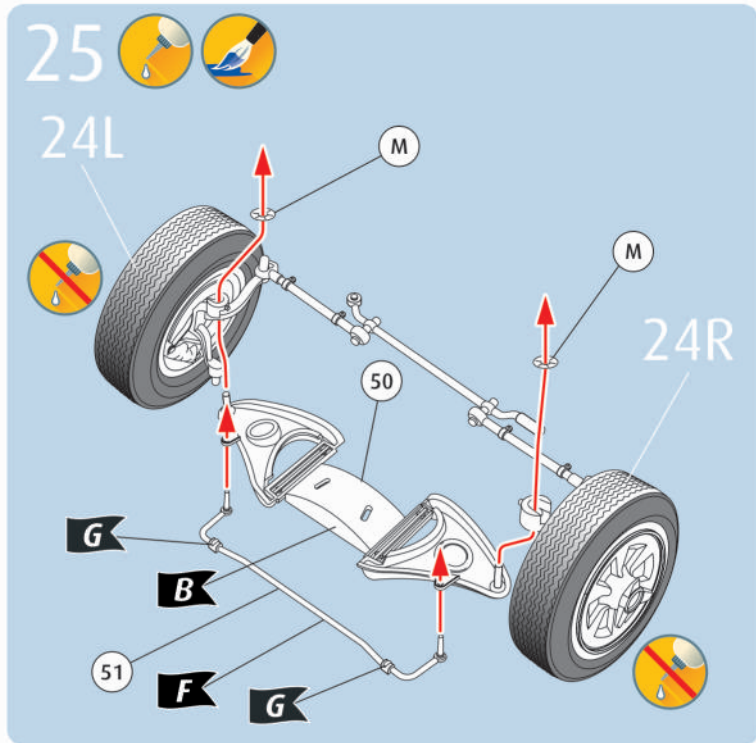

31

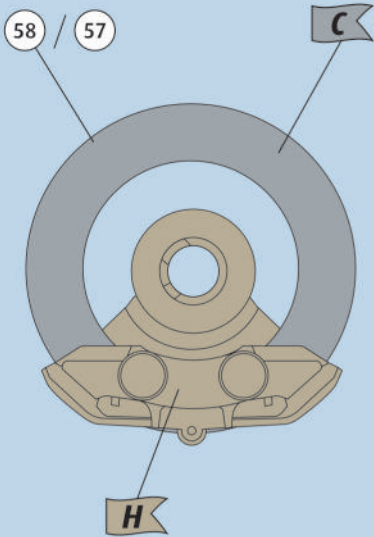

32

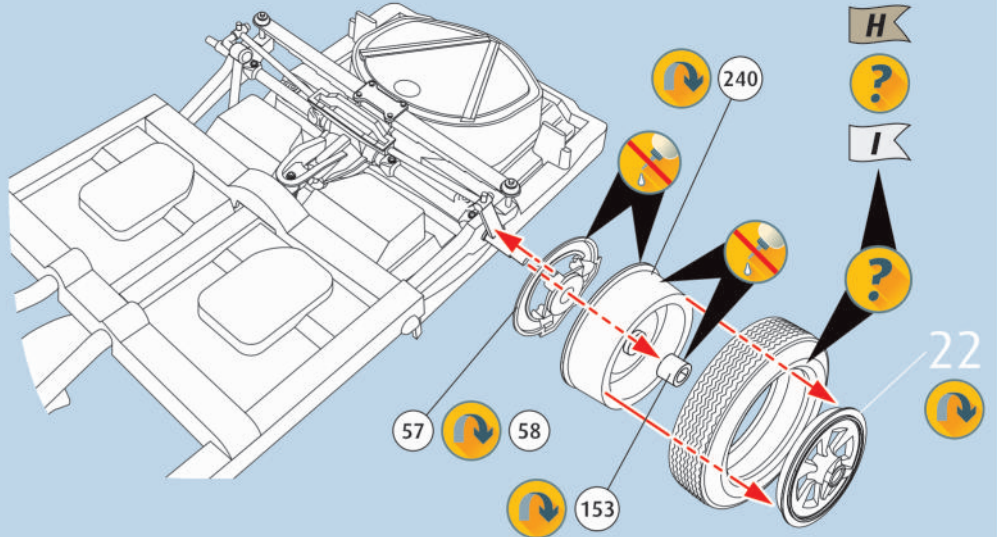

33

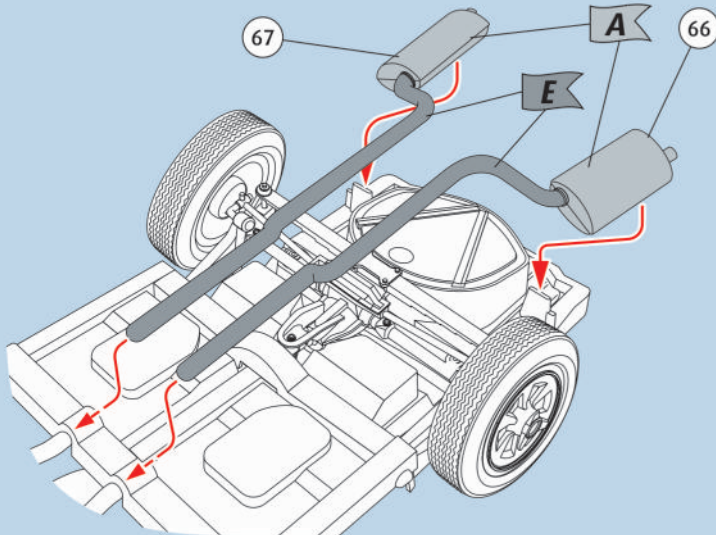

34

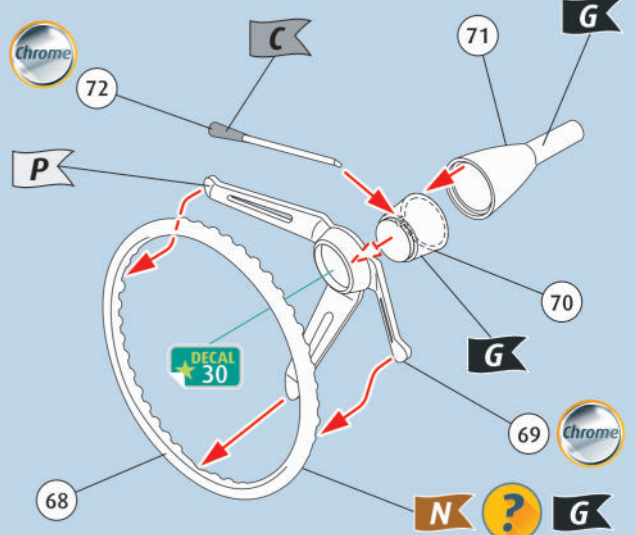

35

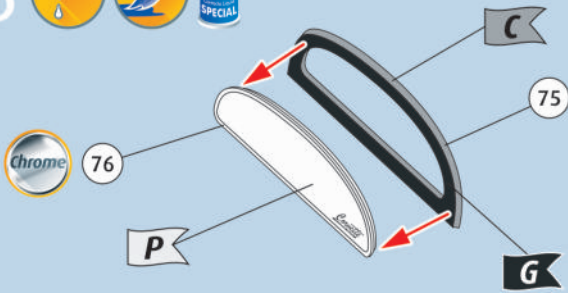

37

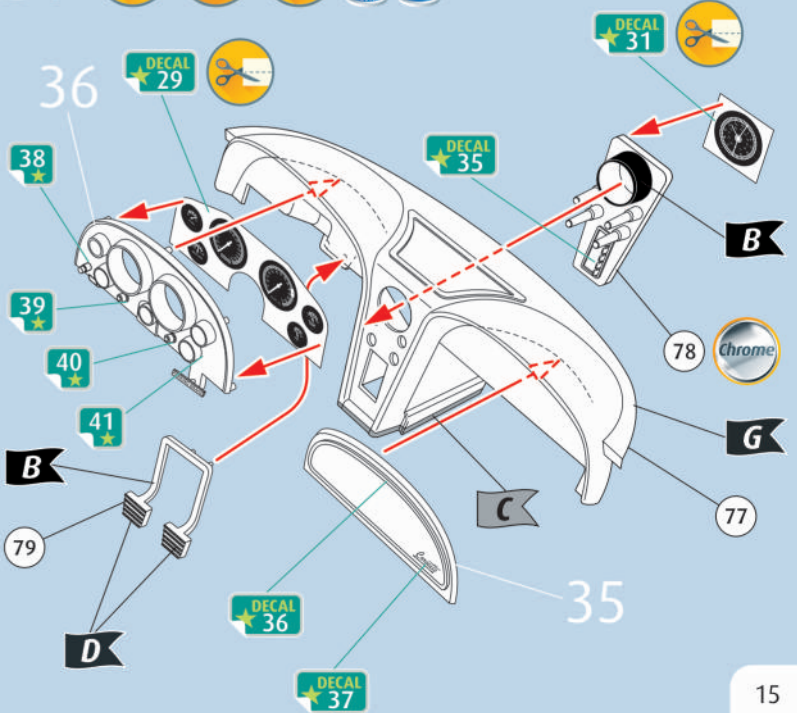

36

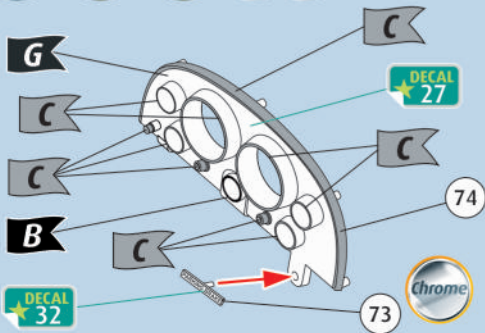

38

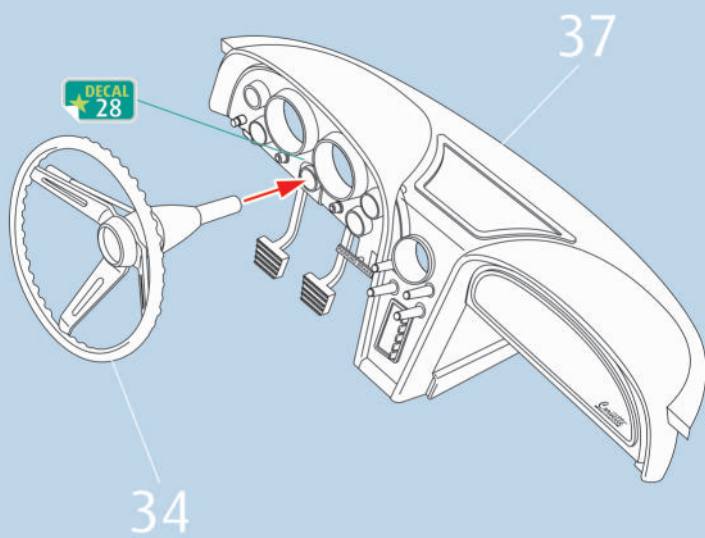

39

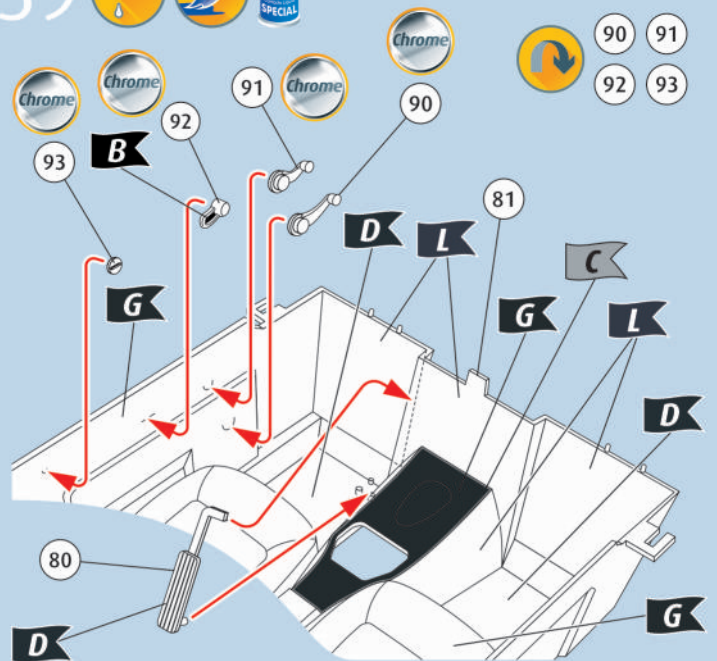

40

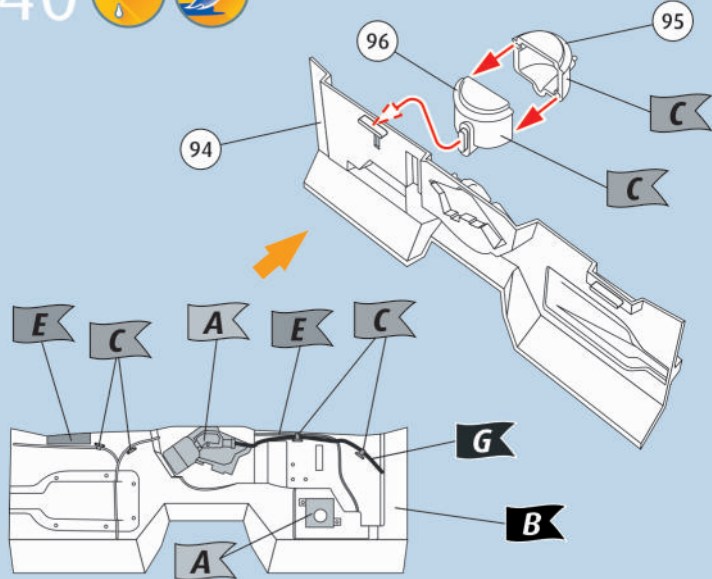

41

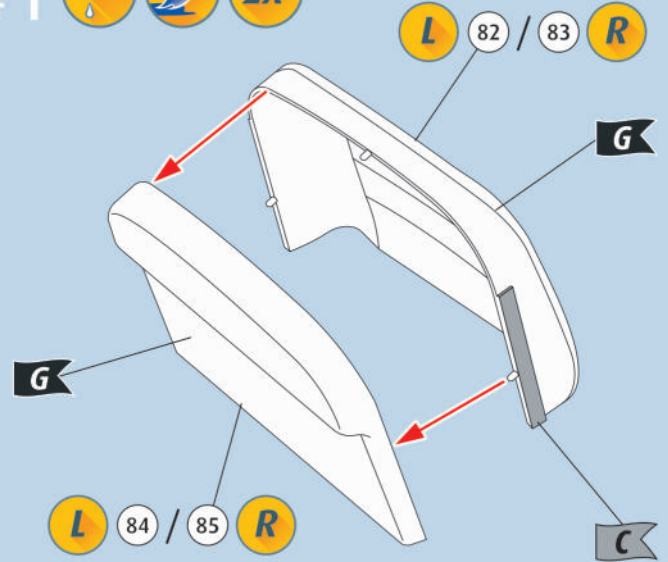

42

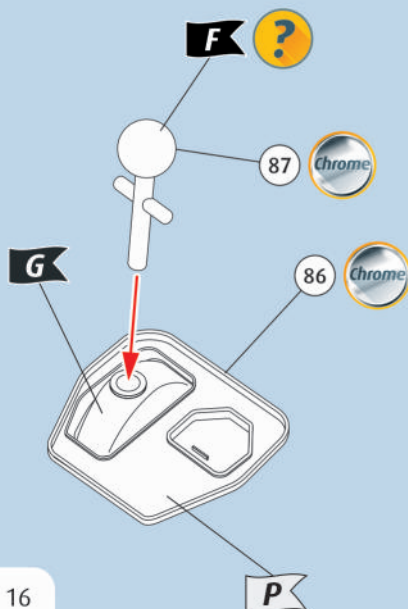

43

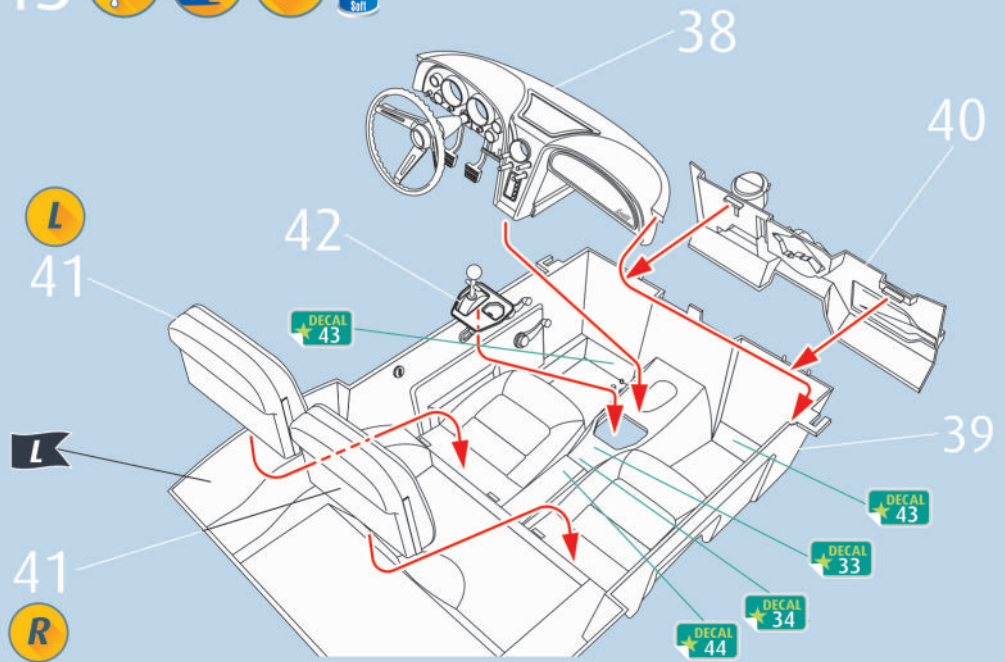

44R

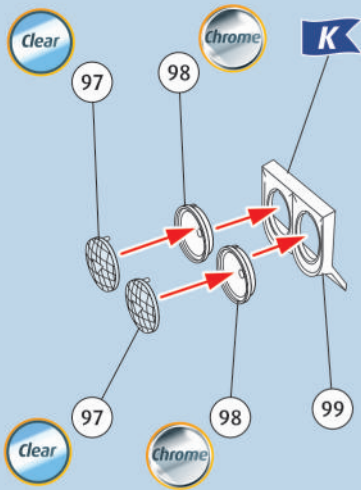

44L

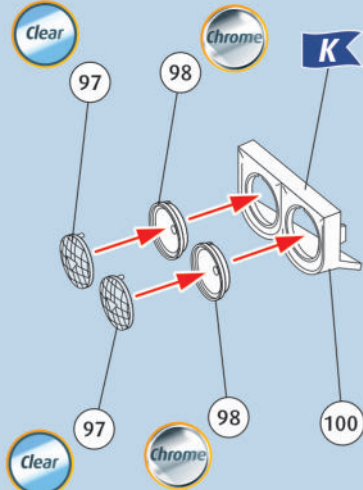

45

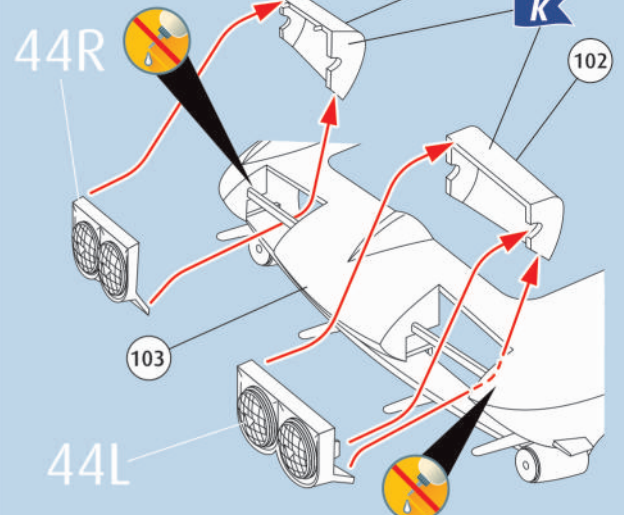

46

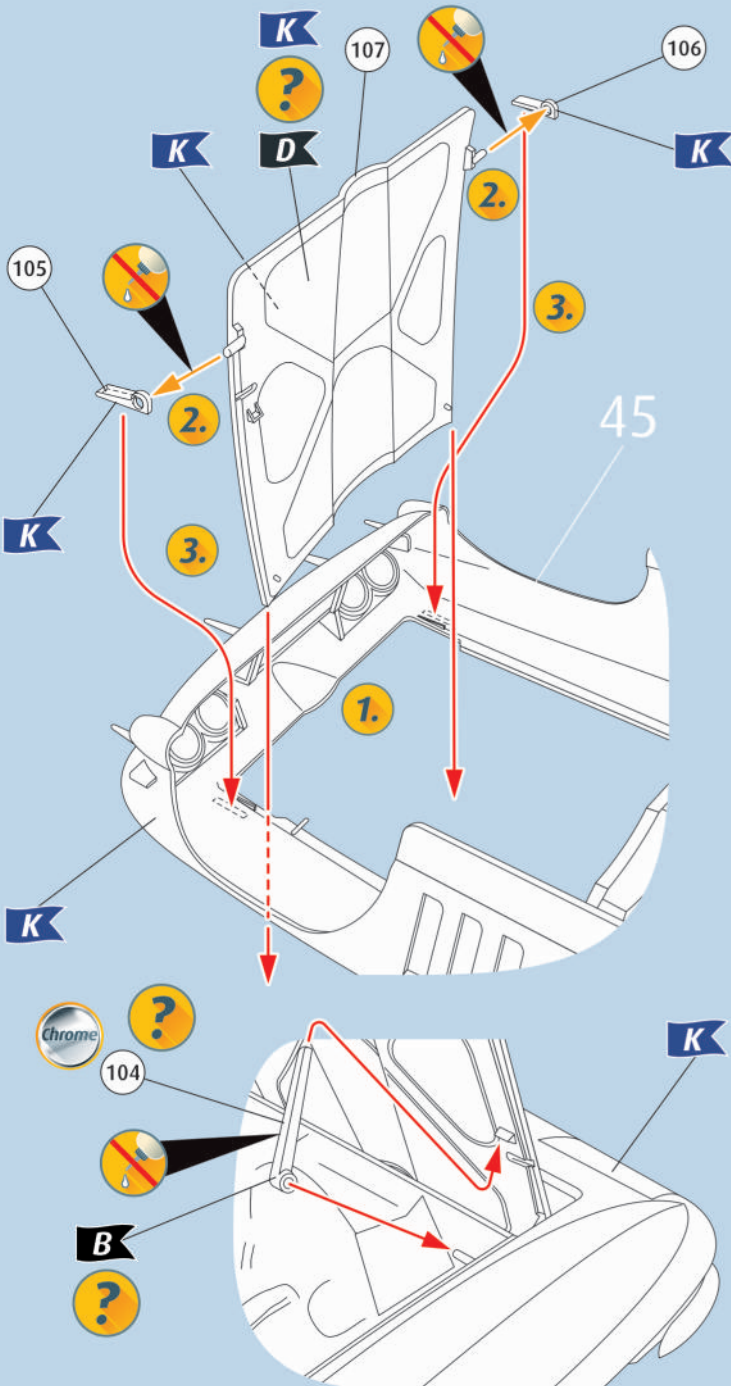

47

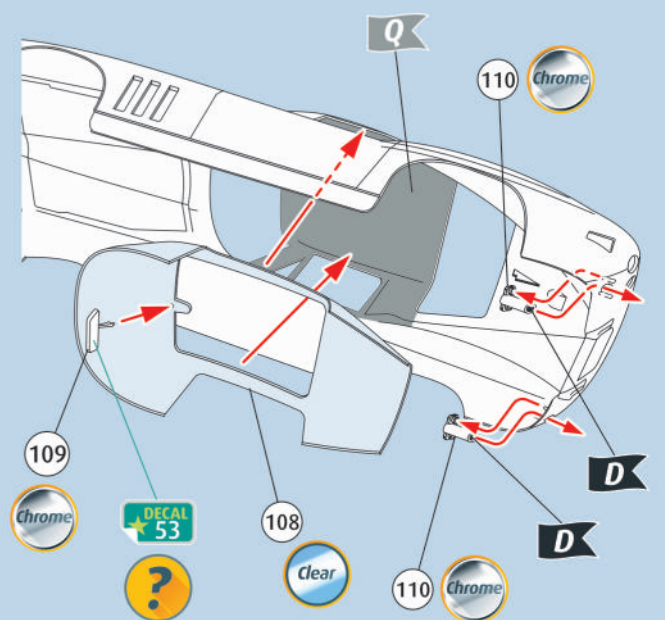

48

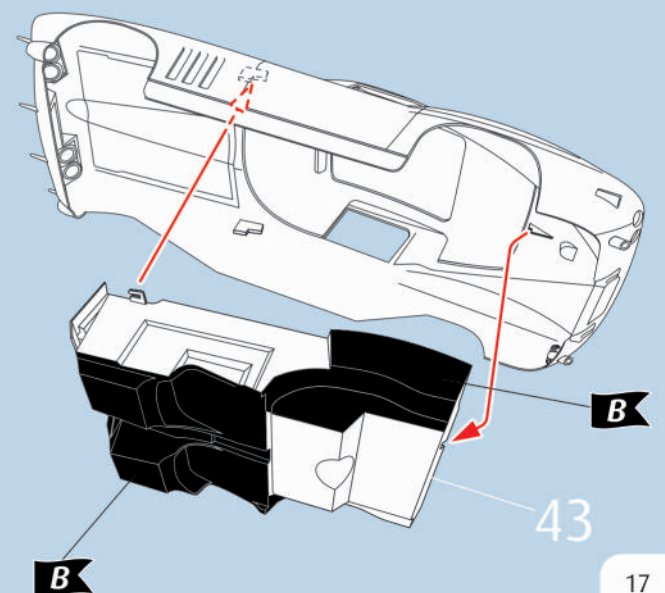

49

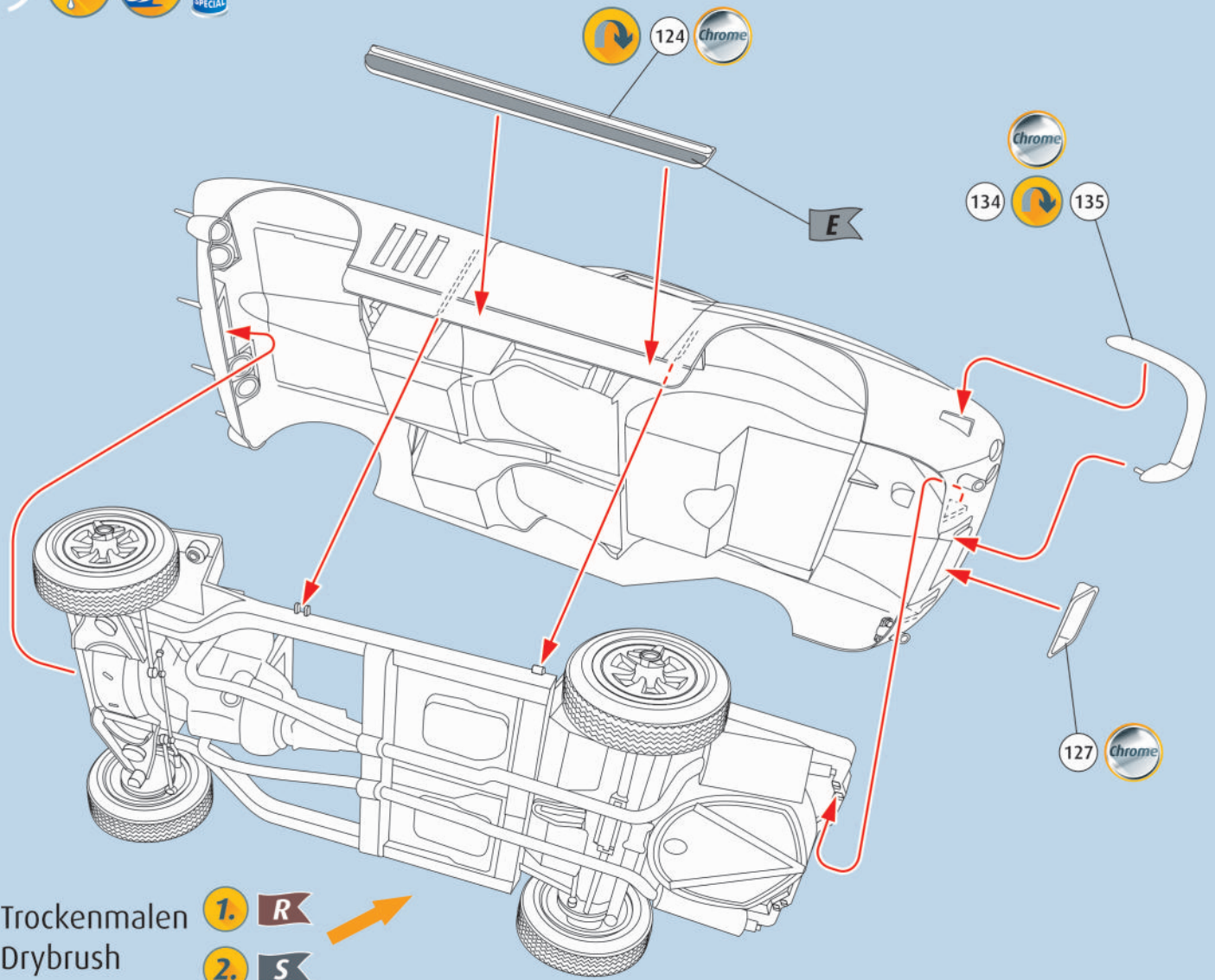

Trockenmalen
Drybrush

- 1. R
- 2. S

50

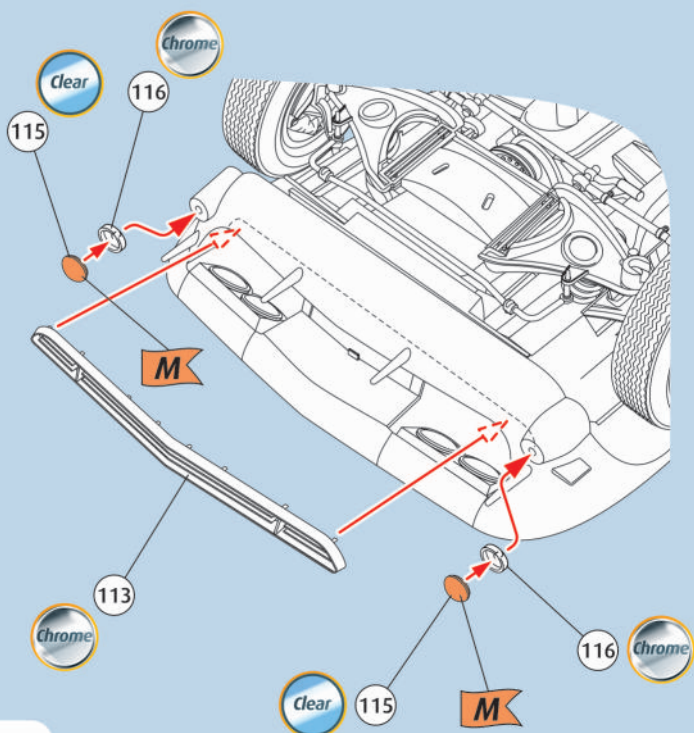

51

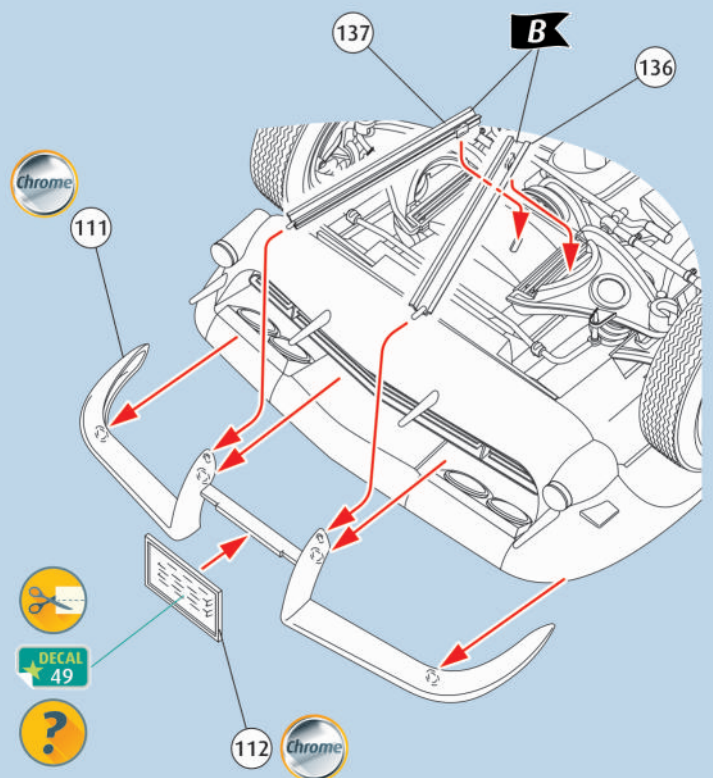

52    

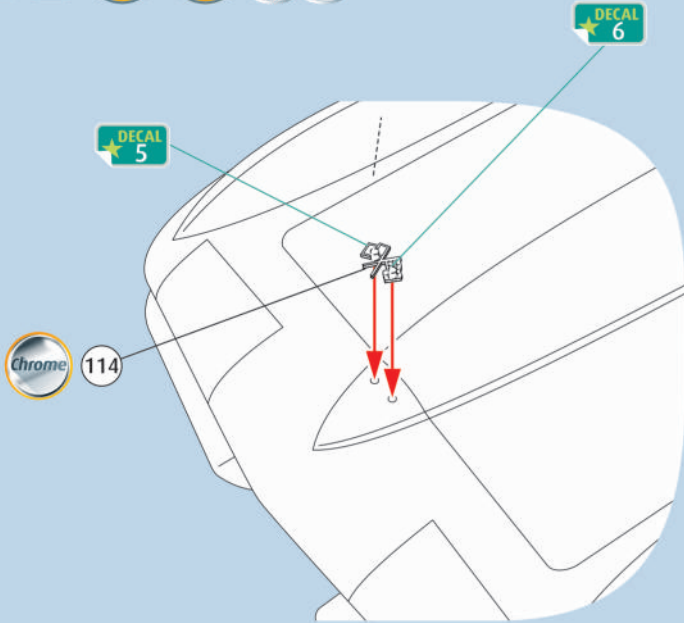

53     

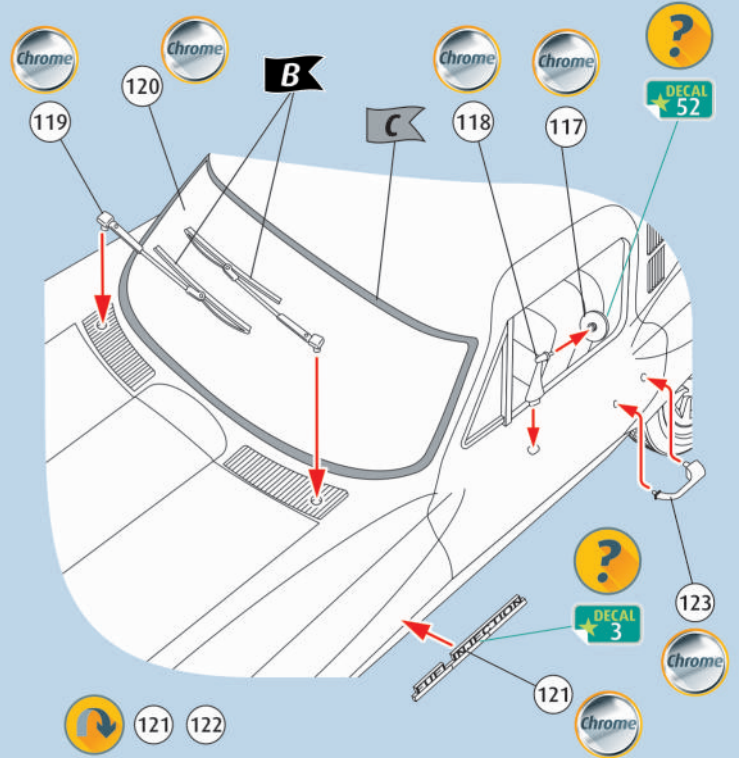

54    

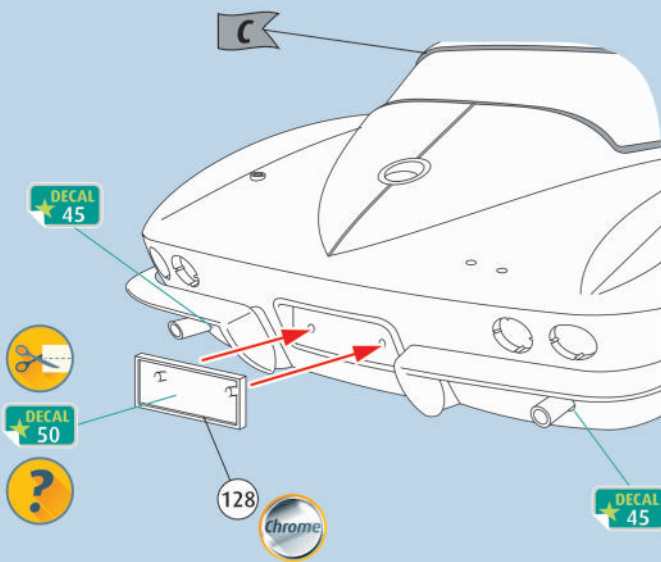

55   

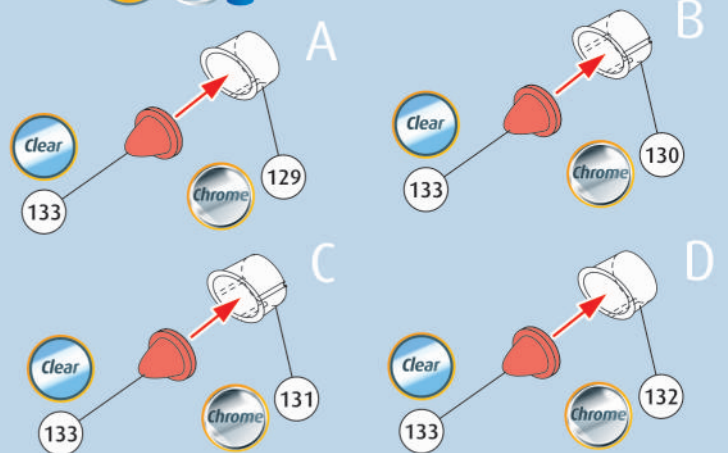

56   

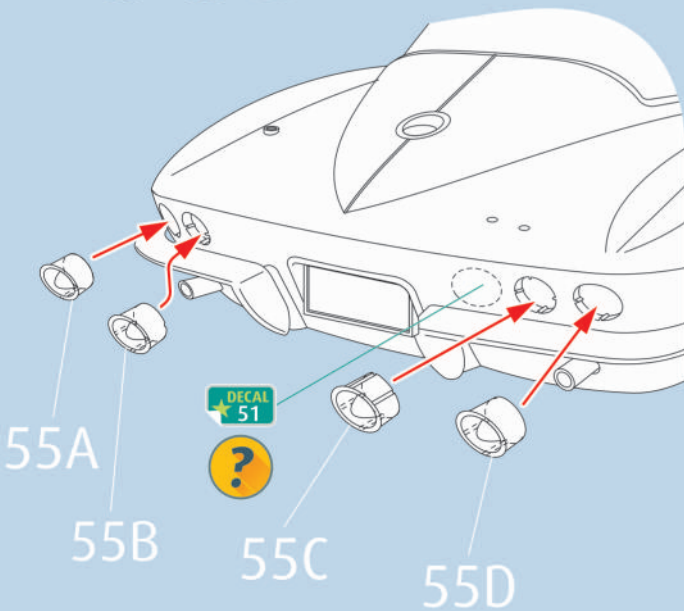

57    

