



Ford Mustang GT 2005

PRINTED IN GERMANY

07355 - 0389

©2006 BY REVELL GmbH & Co. KG



Ford Mustang GT 2005

1964 wird auf der Weltausstellung in New York ein attraktiv gestaltetes Coupé der Öffentlichkeit präsentiert, das ein breites Publikum anspricht und für einen erschwinglichen Preis angeboten wird. Dieser Ford Mustang schlägt ein wie eine Bombe. In einem Jahr werden rund 420.000 Stück von ihm verkauft und der Mustang schreibt damit Geschichte in der amerikanischen Automobilindustrie.

40 Jahre später wird der Mustang endlich wieder zum Leben erweckt. Es ist, als sei die Zeit zurückgedreht worden. Durch sein kraftvolles Retrodesign sieht der jüngste Mustang wieder aus wie damals. Auch das frühere Basiskonzept wurde aufgegriffen: viel Auto für wenig Geld. Der neue Mustang GT orientiert sich mit seiner langen Motorhaube, der markanten Frontschürze, dem kurzem Heck und der coupéförmig gespannten Dachlinie an die Tradition der amerikanischen Muscle Cars. Dazu gehört selbstverständlich ein entsprechender Antrieb. Schon beim Anlassen sendet der 8-Zylinder-Motor starke akustische Reize, die Spaß auf mehr machen.

Ebenso wie außen bleibt die Tradition auch im Innenraum erhalten. In der Mitte des dreispeichigen Lenkrades galoppiert - wie beim Vorgänger - das Marken-Pferd. Der Mustang präsentiert sich innen ansprechend, speziell auch wegen des breiten, metallisch glänzenden Streifens, der sich über die gesamte Breite des Armaturenbretts zieht. Die dicken Chrom-Einfassungen der großen, runden Instrumente tun ein Übriges, auch wegen der nostalgischen Ziffern auf den übersichtlichen Anzeigen. Bei den Sitzen und der Sitzposition macht sich die Verbesserung äußerst positiv bemerkbar. Das neu entwickelte Fahrwerk, die vergrößerten Brems Scheiben und ABS runden das Gesamtbild eines kraftvollen, dennoch bequemen und sicheren Fahrzeugs ab. Das Fahrvergnügen geht aber eindeutig auf den dreifreudigen Motor zurück. Das Triebwerk mit 4,6 Litern Hubraum spricht sehr schnell an und bietet nicht nur Kraft und Leistung. Der V8 überzeugt mit seinem brabbelnden Bass bei niedrigen Drehzahlen und Heavy-Metal-Gehämmer, wenn man dem 300 PS (221 kW) starken 8-Zylinder die Sporen gibt. Seit 2005 ist der Ford Mustang GT als US-Import erhältlich.

Ford Mustang GT 2005

In 1964, at the World Fair in New York, an attractively designed coupé was launched that was intended to appeal to a wide public and was offered at a reasonable price. This Ford Mustang went like a bomb. In just one year 420,000 were sold and the Mustang made its mark in the annals of the American motor industry.

40 years on the Mustang has finally come back to life. It is as if time has been turned back. With its forceful retro design, this latest Mustang looks much as it did before. It also adheres to the earlier basic concept: a lot of car for a little money. The new Mustang GT, with its long bonnet, prominent front apron, blunt rear and taut coupé-style roof line, is based on the tradition of the American "muscle cars". Naturally it has an engine to match. Immediately on start up the thrilling voice of the 8-cylinder engine is heard, and the pleasure is compulsive.

As with the exterior, tradition has been adhered to inside. In the centre of the three-spoke steering wheel the trade mark horse gallops - just as it did before. The Mustang has an attractive interior and the shiny wide metallic strips across the whole of the dashboard are also special. The thick chrome rims of the big round instrument, with their nostalgic figures on clear indicators are something else. The improvements to the seats and the seating position are immediately apparent. The newly developed chassis, the enlarged brake discs and the ABS round off the picture of a powerful, but comfortable and safe car. The pleasure of driving it however is patently attributable to the lively engine. This 4.6 litre power pack responds right away and offers more than just power and performance. The V8 with its throaty growl at low speeds and heavy metal throb when the 300 bhp (221 kW) 8-cylinder engine is spurred on is persuasive. Since 2005 the Ford Mustang GT has been available as a US import.

Form hergestellt und im Eigentum von Revell GmbH & Co. KG/Revell Monogram Inc. Widersetzliche Nachahmungen werden gerichtlich verfolgt.
Ce produit est propriété de la société Revell GmbH & Co. KG/Revell Monogram Inc. Toute réimpression ou duplication frauduleuse sera suivie de poursuites en justice.
Modelado y en propiedad de Revell GmbH & Co. KG/Revell Monogram Inc. Limitaciones de marcas serán perseguidas por la ley.
Forma prodotta della Revell GmbH & Co. KG/Revell Monogram Inc. e di proprietà della stessa impresa, la quale procederà legalmente contro ogni imitazione abusiva.
Malli on Revell GmbH & Co. KG/Revell Monogram Inc. valmistama ja omistavalla. Laitteeseen kopioiminen kukaan puuttamaan oikeudellisiin toimenpiteisiin.
Formen er producer og eies av Revell GmbH & Co. KG/Revell Monogram Inc. Etterfølgende uten tillatelse vil bli gjerstand for rettslig forfølgelse.
Produkcia i prawa własności firmy Revell GmbH & Co. KG/Revell Monogram Inc. Nielegalne podrobienie jest zabronione pod odpowiedzialnością sądową.
A forma edeltésje és a tulajdonjog bíróságra a Revell GmbH & Co. KG/Revell Monogram Inc. A jogtalan utárművelés és hamisítványok bírósággal üldöztek.

Model manufactured by and property of Revell GmbH & Co. KG/Revell Monogram Inc. Illegitimate imitations are subject to prosecution.
Vorm vervaardigd door en eigendom van Revell GmbH & Co. KG/Revell Monogram Inc. Onrechtmatige nabootelingen worden gerechtelijk vervolgd.
Formas producidas e de propriedade de Revell GmbH & Co. KG/Revell Monogram Inc. Copias não autorizadas serão processadas juridicamente e caso determinado na lei.
Modellet tilberedt av och tillhör Revell GmbH & Co. KG/Revell Monogram Inc. All kopiering beivras enligt lagen om upphovsrätt.
Mallin valmistama ja omistava Revell GmbH & Co. KG/Revell Monogram Inc. Illegittimitäteen vastustetaan oikeudellisin keinoin.
Mogun struktura i materiai eformavimasas forma Revell GmbH & Co. KG/Revell Monogram Inc. Iepimomasneme uzturama i nepatvarama i apvaldama nepatve.
Huvalljy katasovestymys tai kopiointi ilman Revell GmbH & Co. KG/Revell Monogram Inc. Oikeusperusteista lupauksen tai kostonkannan katoa.
Tva by vyrobena firmou Revell GmbH & Co. KG/Revell Monogram Inc. a je jejim vlastnickim. Prot nezakonim napodobenim se bude postoupel soudni zastou.
Forma je proizvedena in je vlasništvo Revell GmbH & Co. KG/Revell Monogram Inc. Neovlašćeno kopje budo pravno kažnjeno.

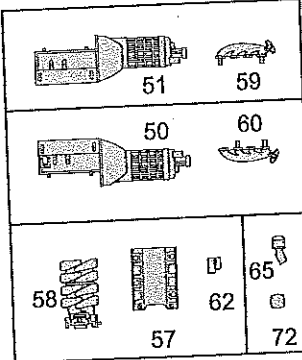
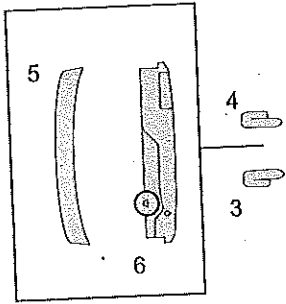
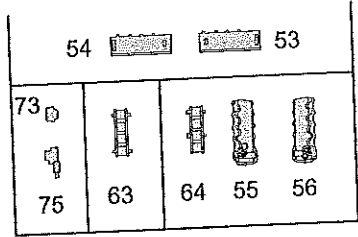
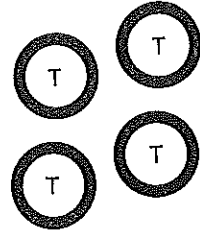
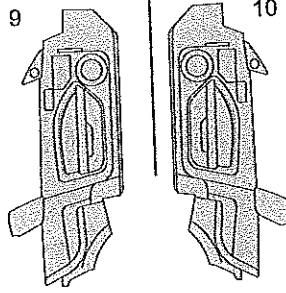
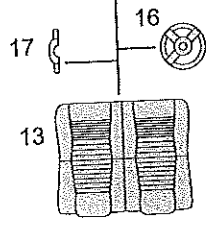
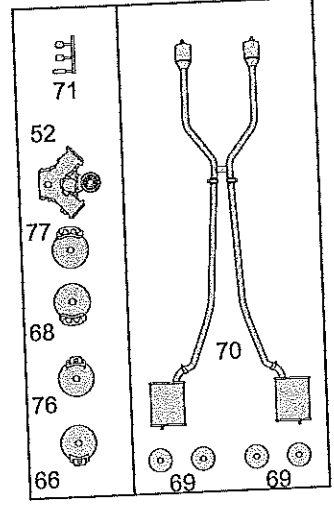
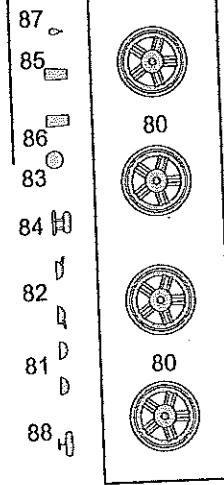
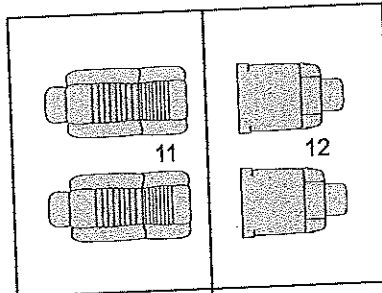
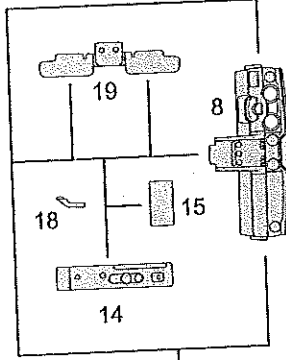
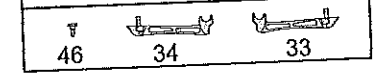
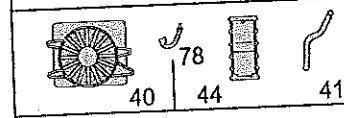
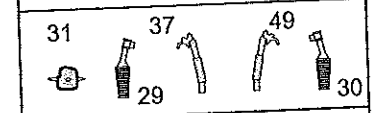
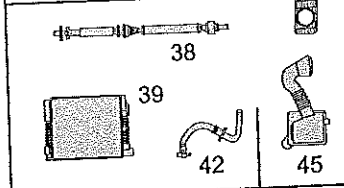
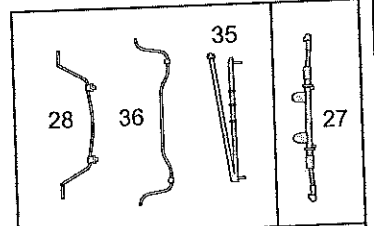
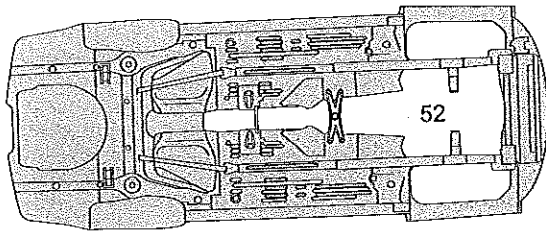
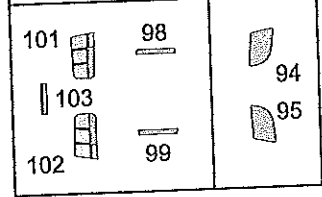
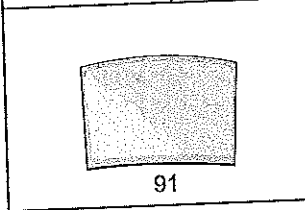
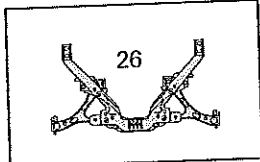
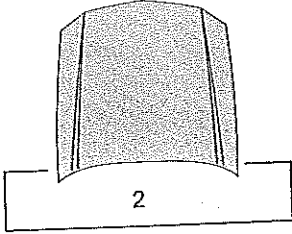
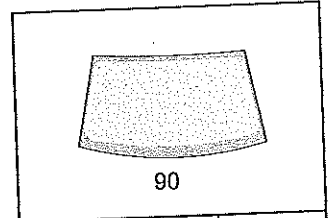
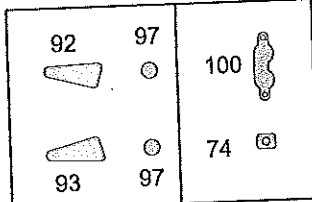
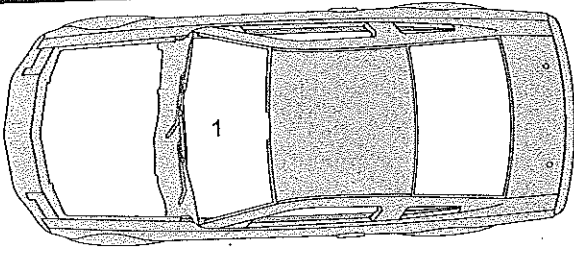

- M1
- M1
- M2
- M2
- M2
- M2

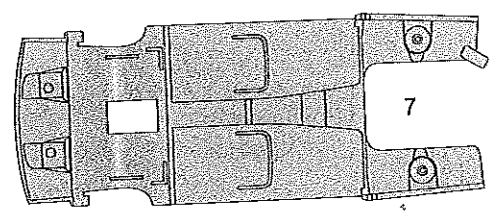

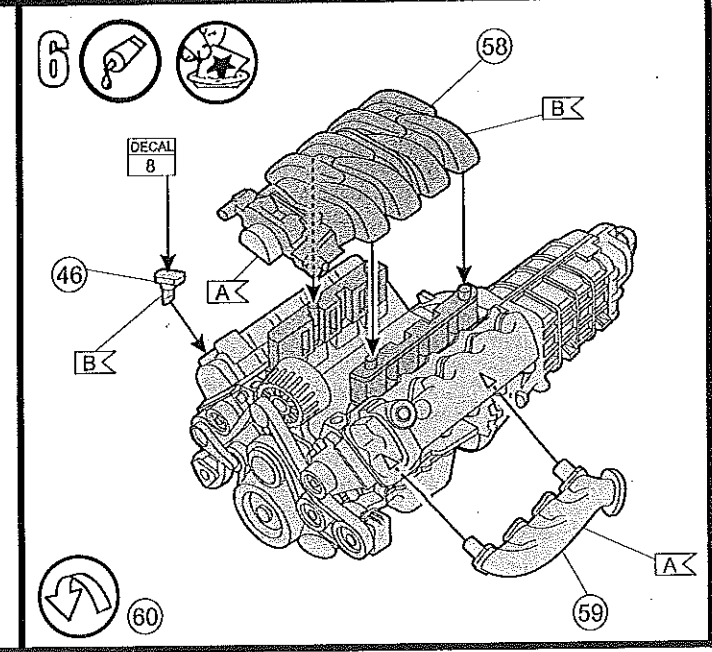
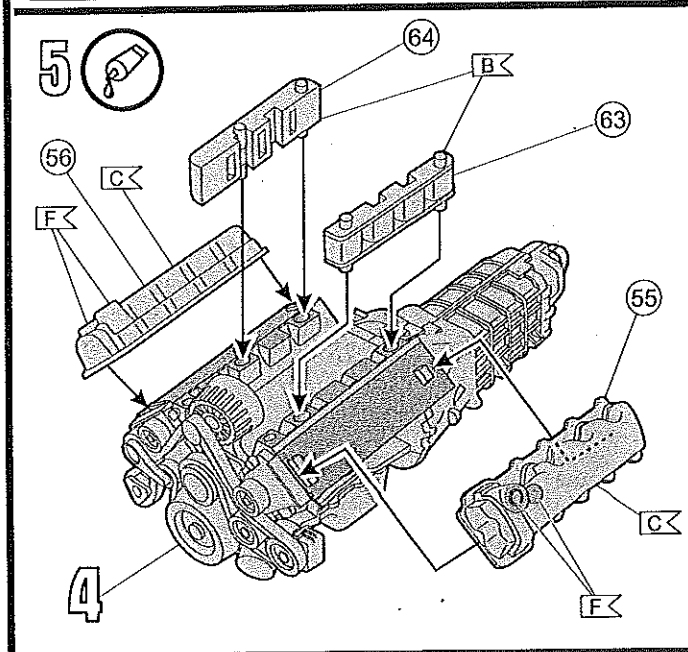
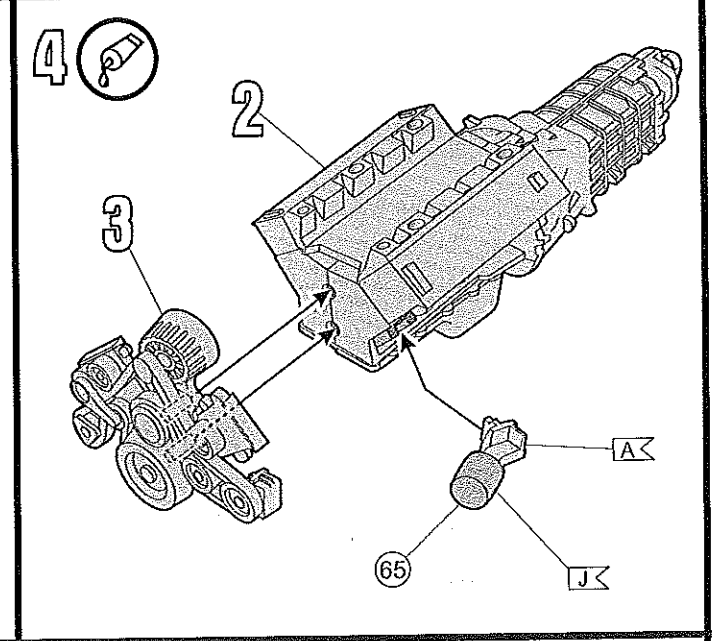
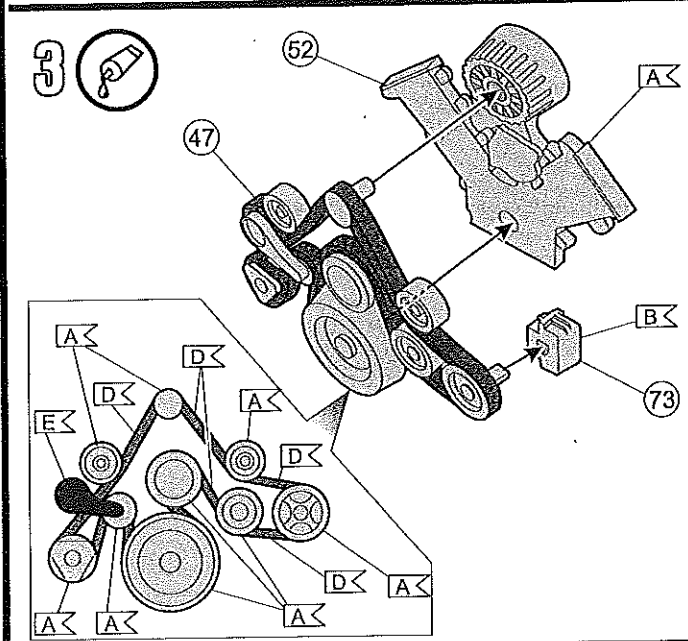
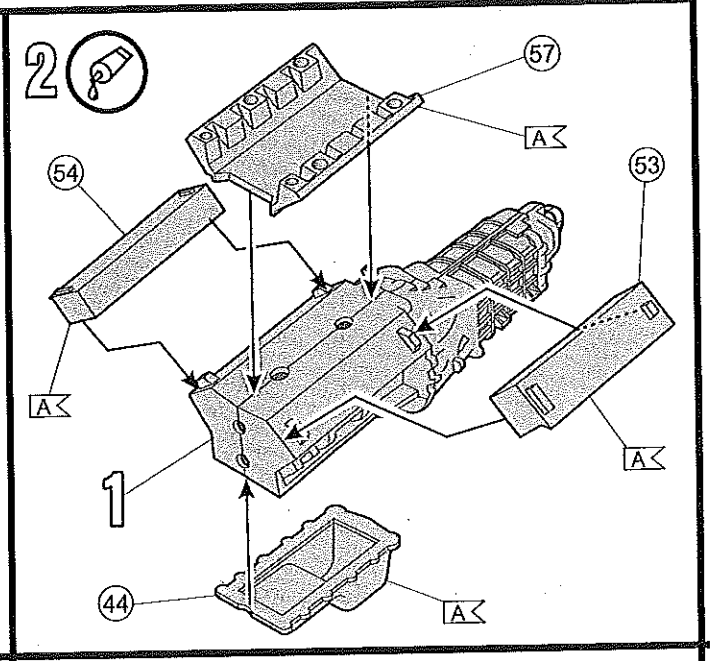
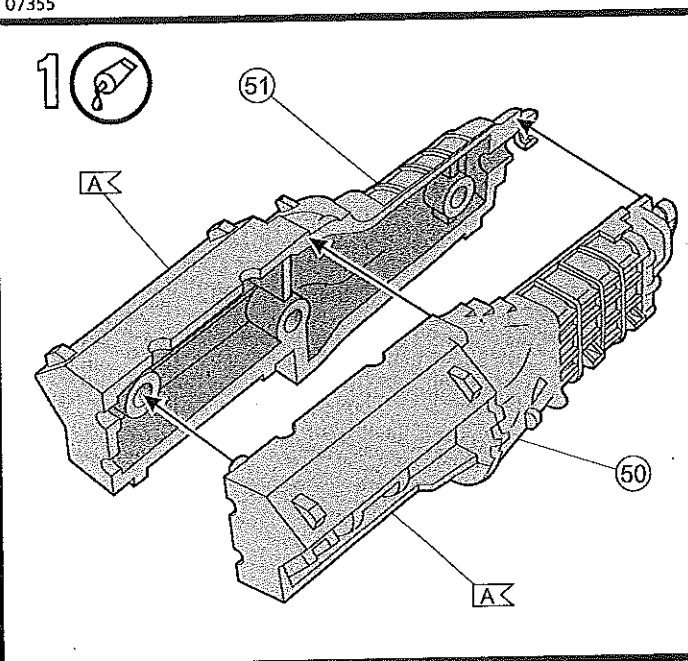

7 

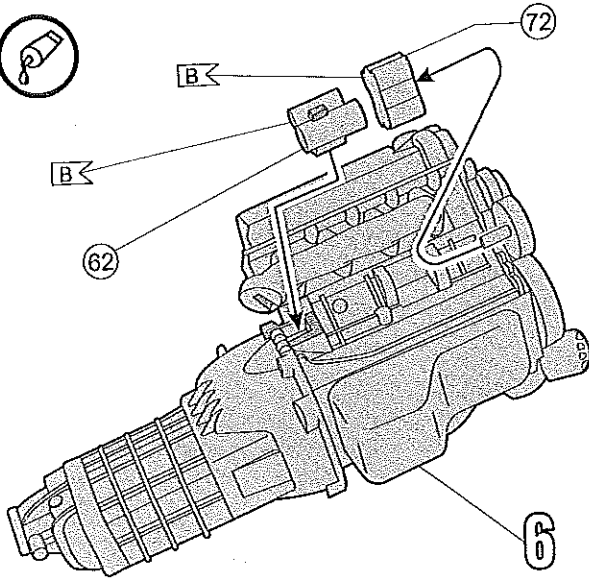

8 

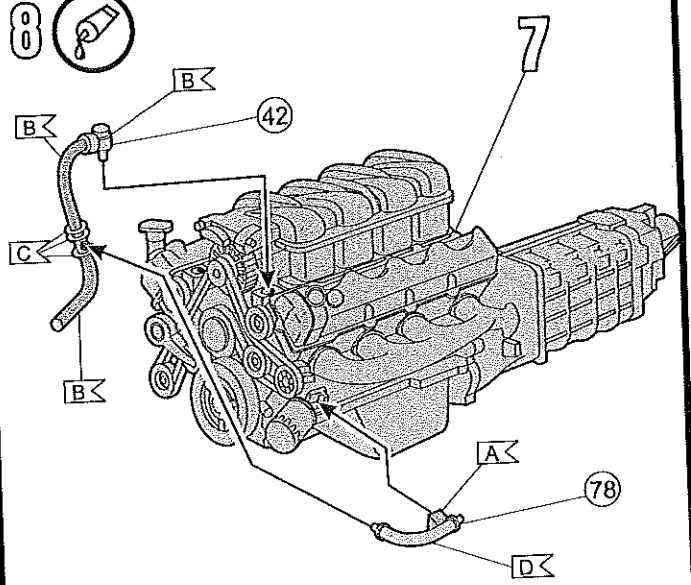

9 

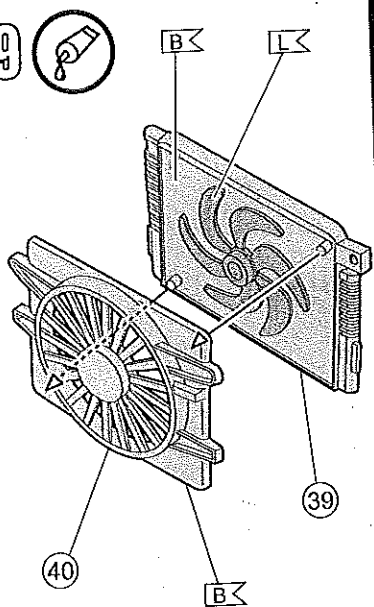

10 

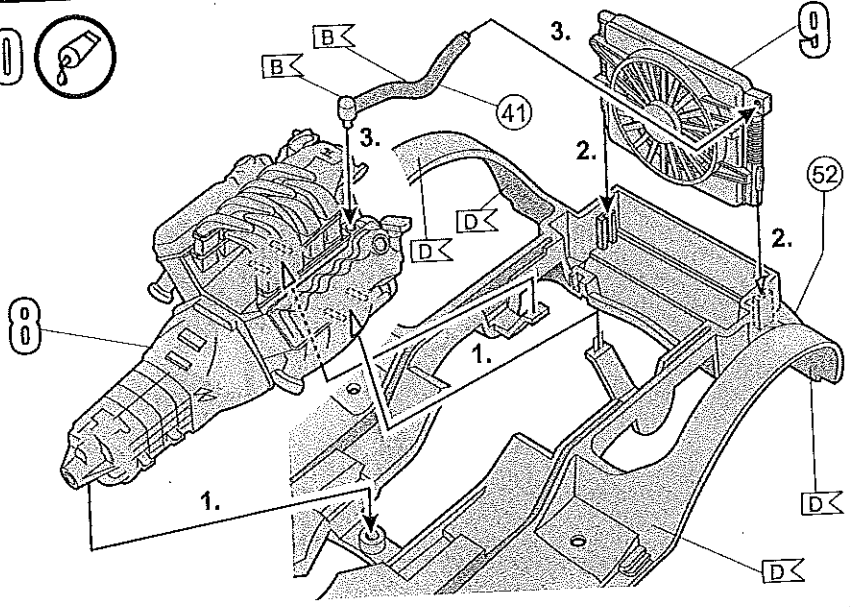

11 

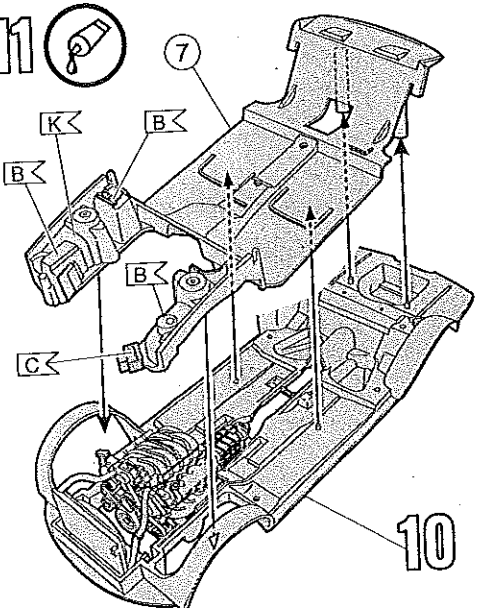

12 

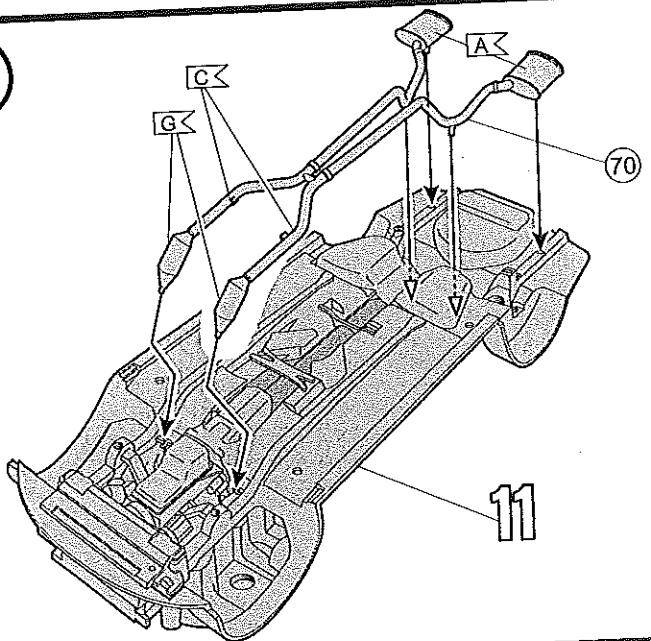

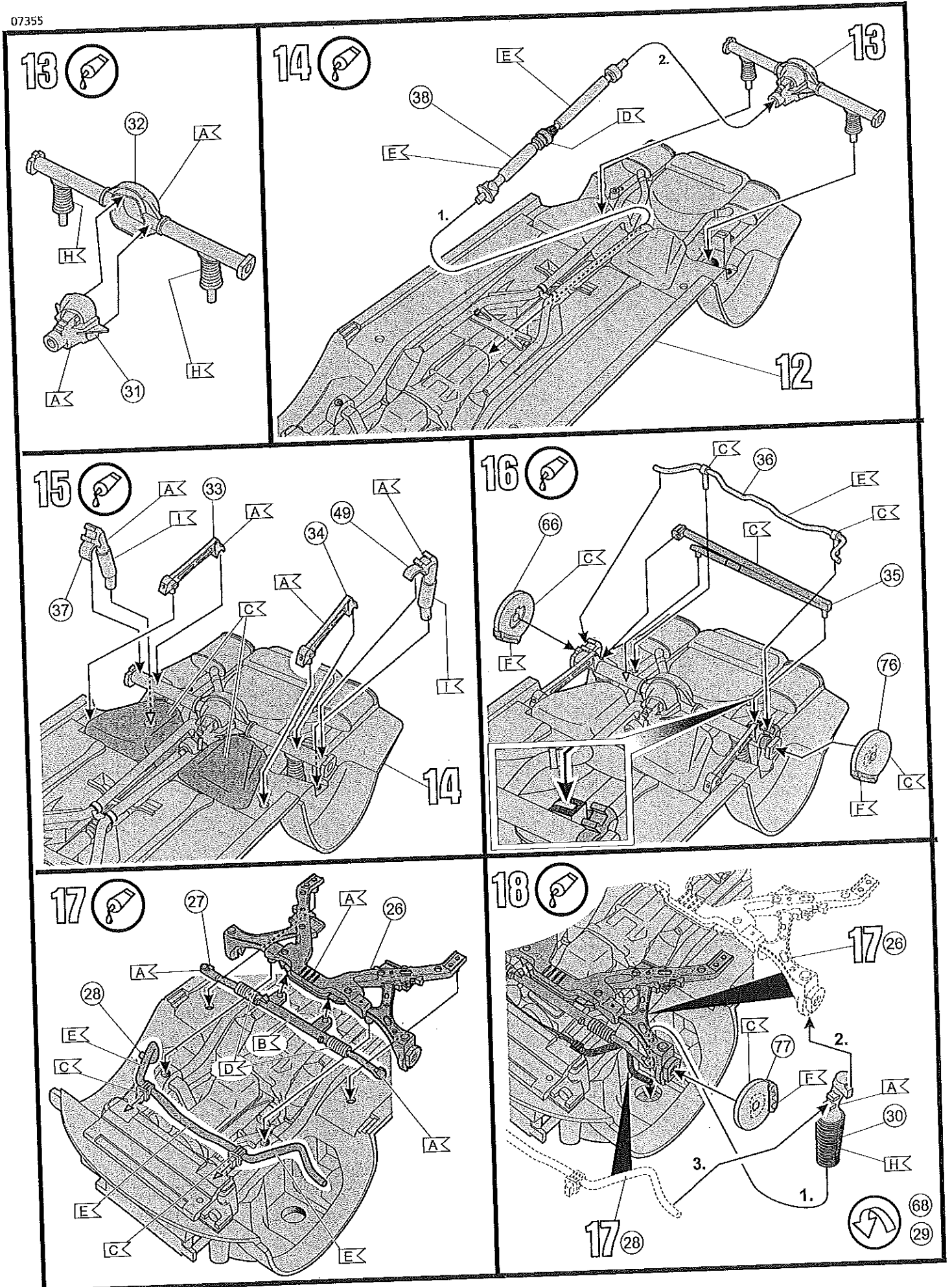

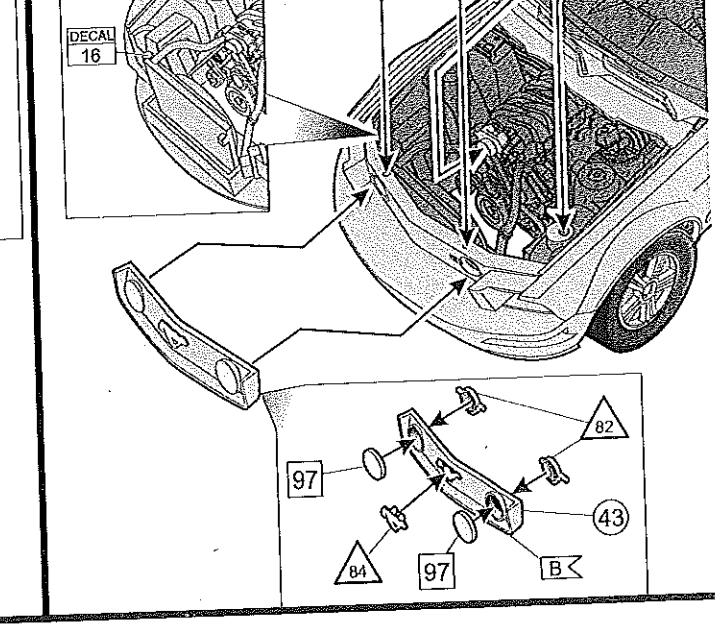
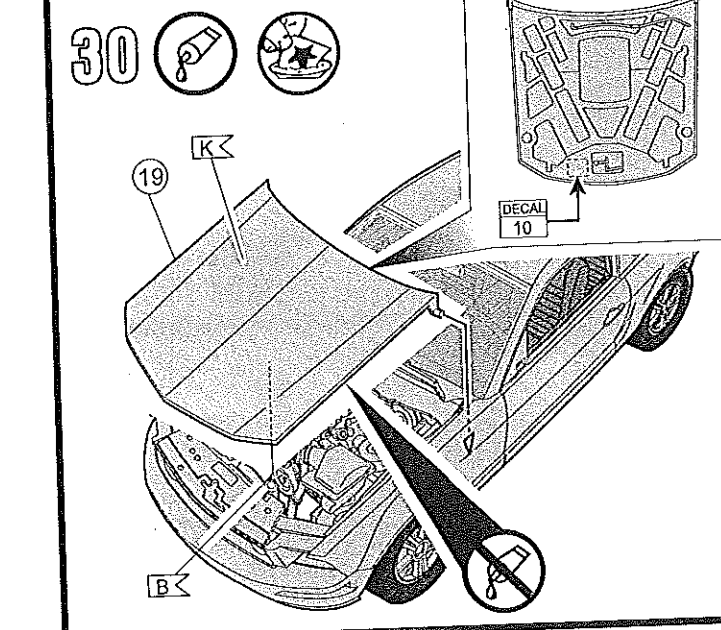
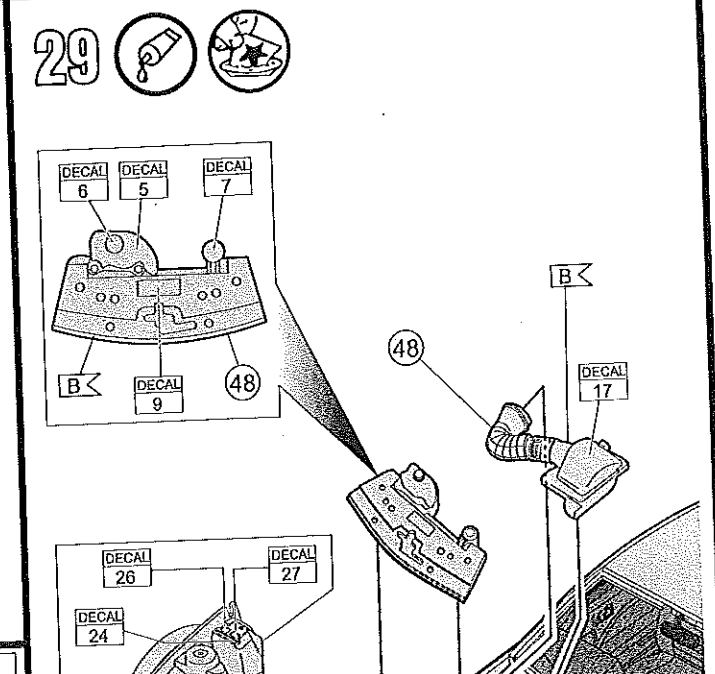
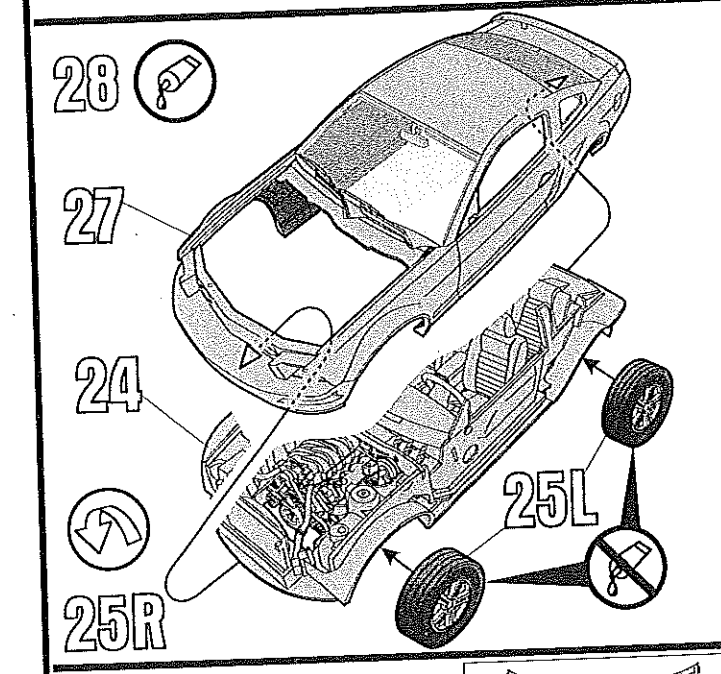
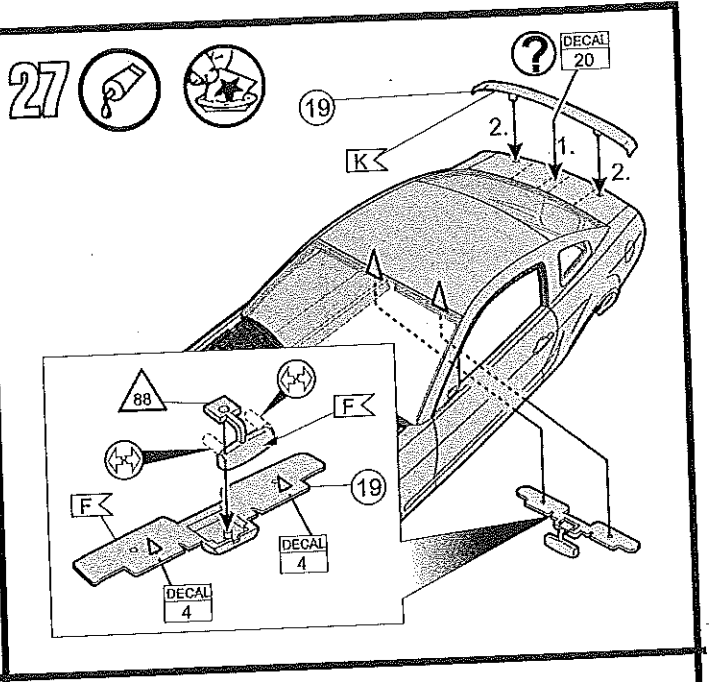
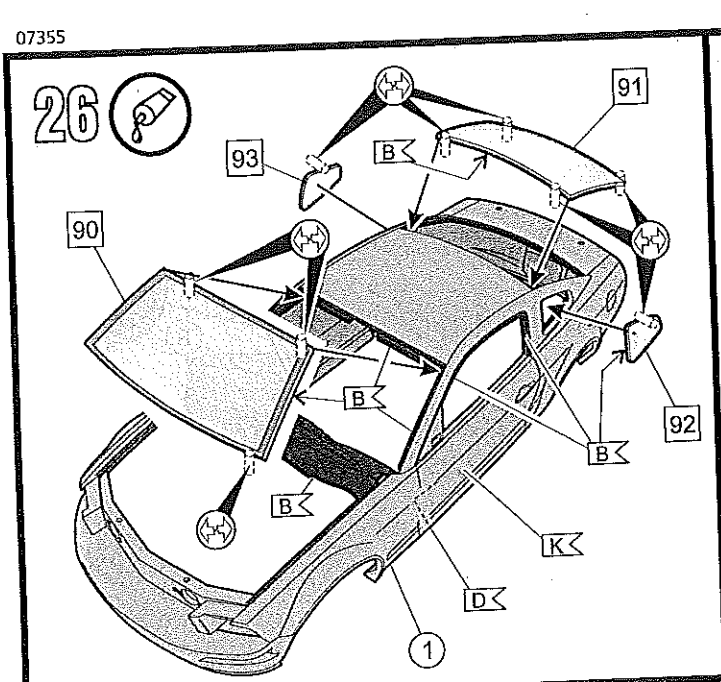

31

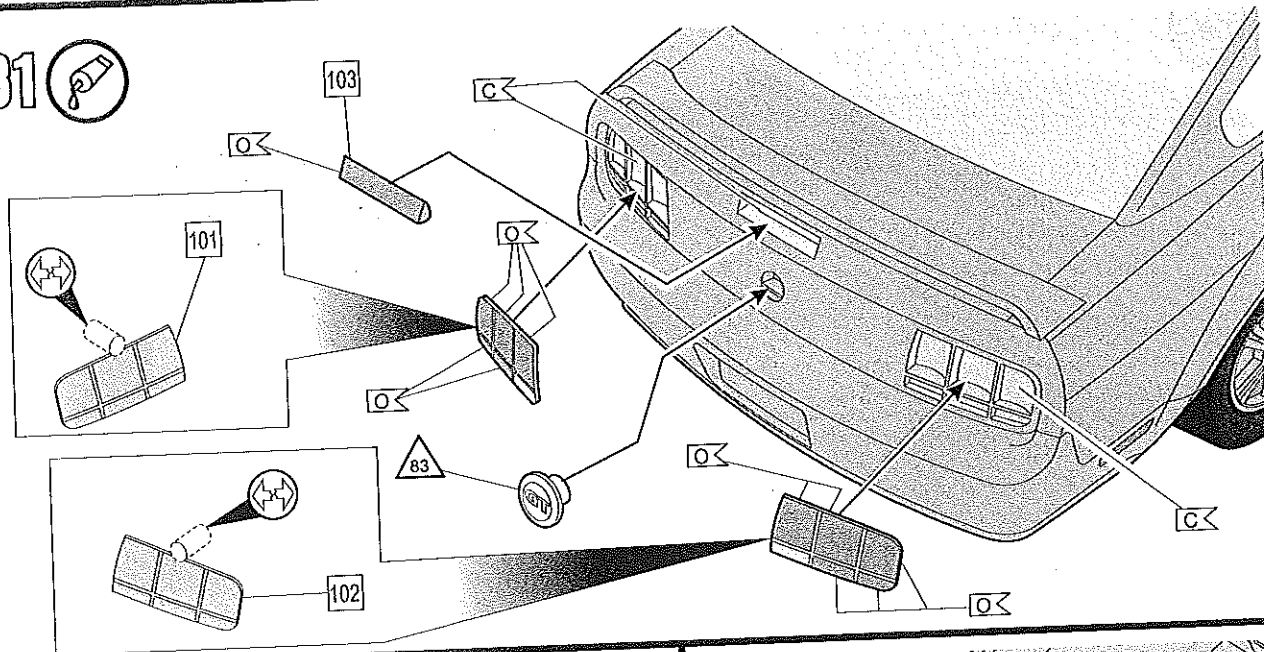

32

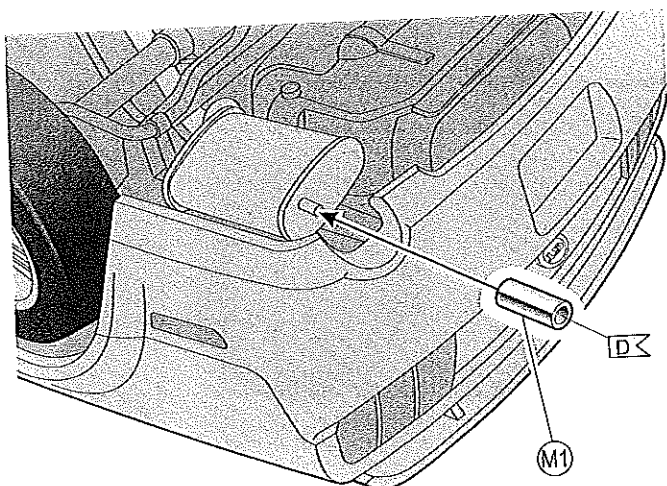

33

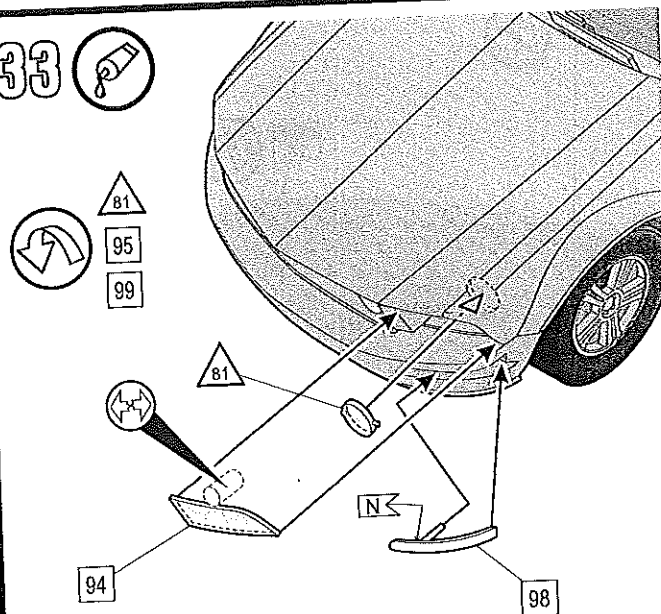

34

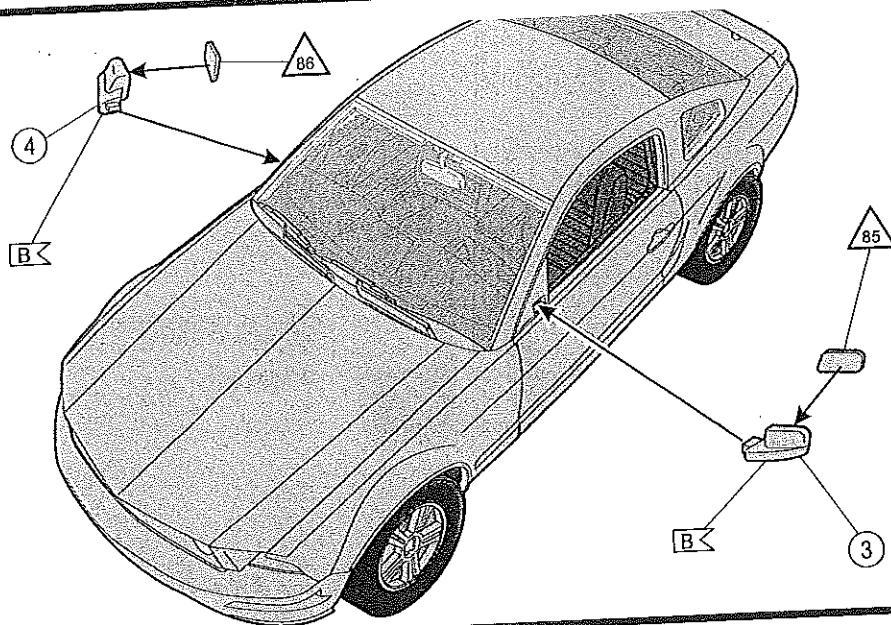

35

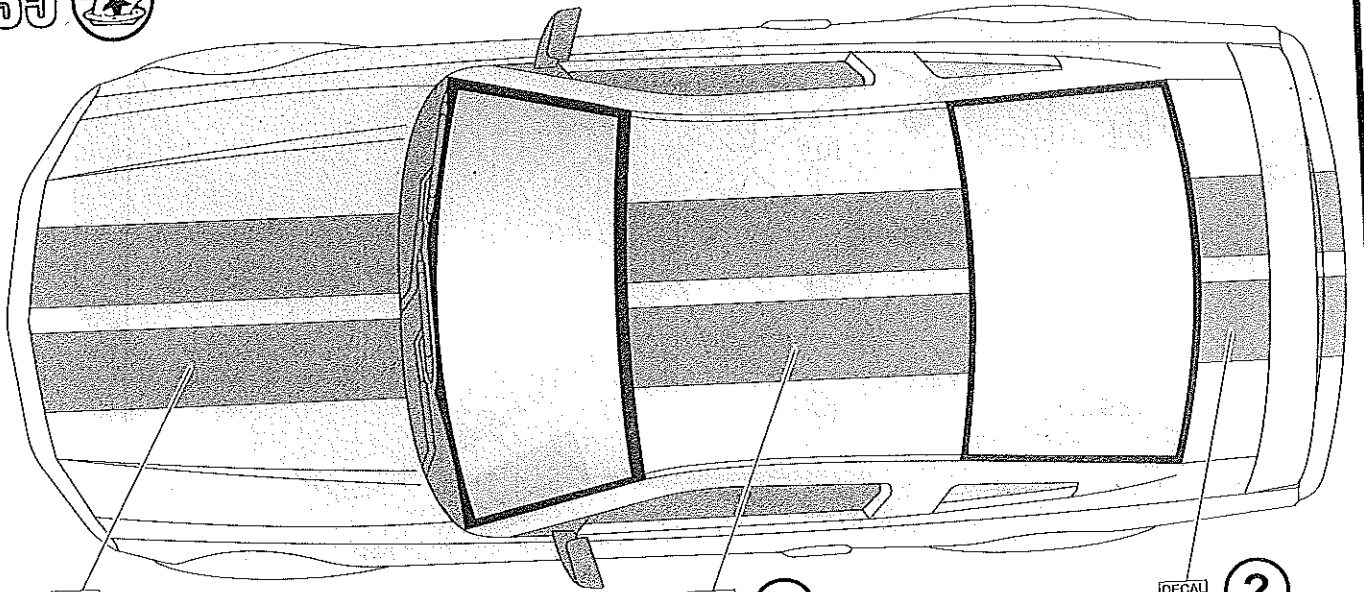

DECAL 18



DECAL 19



DECAL 20

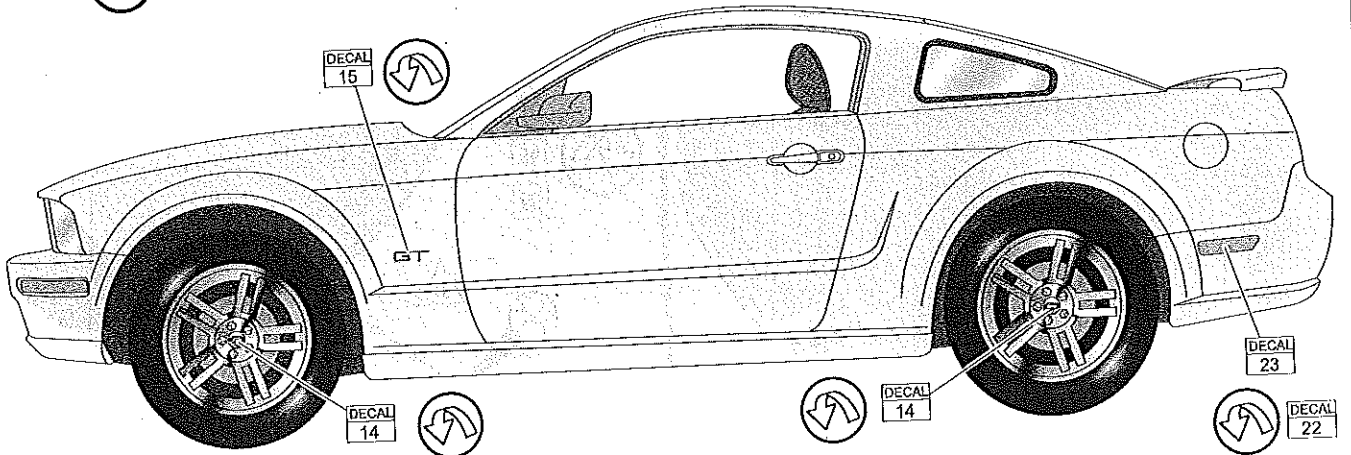

DECAL 15



DECAL 14



DECAL 14



DECAL 23



DECAL 22

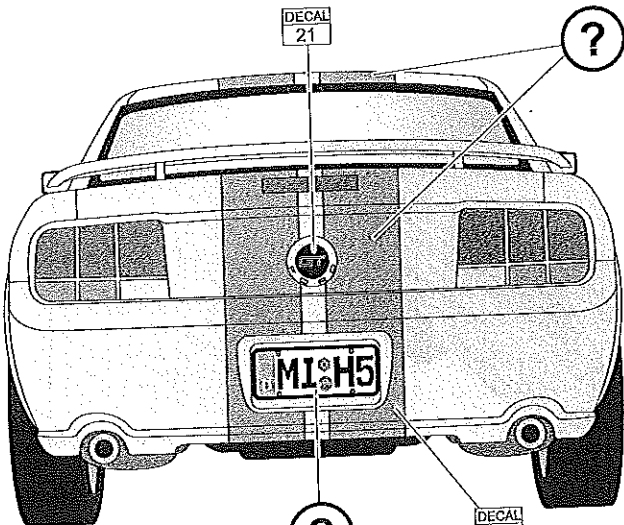

DECAL 21



DECAL 25

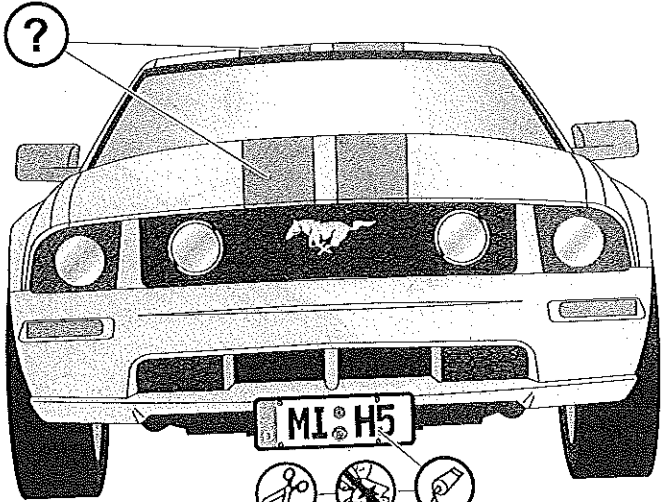

DECAL DECAL DECAL DECAL DECAL DECAL DECAL DECAL
29 31 33 35 37 39 12 13

DECAL DECAL DECAL DECAL DECAL DECAL
28 30 32 34 36 38