



HAWKER HURRICANE Mk. II B

A 04138 - 0389

©1998/2008 BY REVELL GmbH & Co. KG

PRINTED IN GERMANY

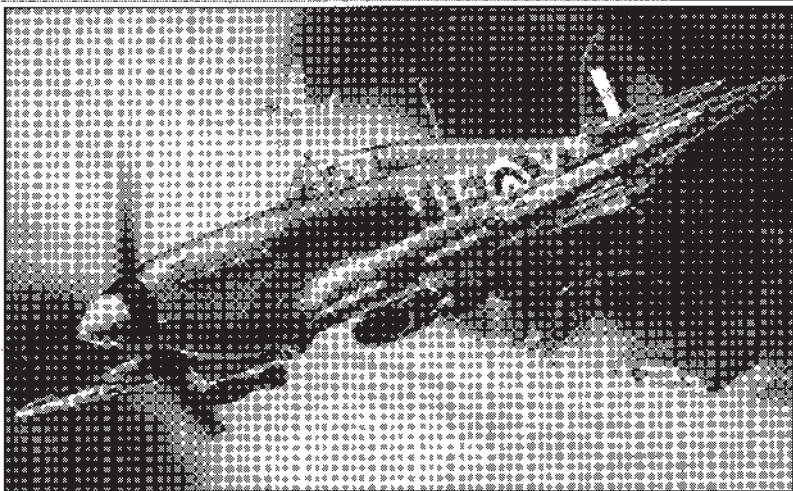

Hawker Hurricane Mk. II B

Als die Leistungsfähigkeit von Doppeldecker-Jagdflugzeugen im Laufe der 30er Jahre ihre Grenzen erreicht hatte, stieg die Nachfrage nach stärkeren und schwer bewaffneten Eindecker-Flugzeugen. Die Firma Hawker baute die von einem Rolls-Royce Merlin-Motor getriebene "Fury Monoplane", ein neues Jagdflugzeug, das zur legendären Hurricane wurde. Die Hurricane absolvierte ihren Erstflug am 06. November 1935; die erste serienproduzierte Mk. II flog im Oktober 1937. Große Stückzahlen wurden von der RAF in Auftrag gegeben und die ersten Hurricanes bereits 1937 in Dienst gestellt. Bei Ausbruch des Krieges im September 1939 hatte das RAF Fighter Command (RAF Jagdkommando) 14 Einsatzstaffeln der mit 8 Maschinengewehren ausgestatteten Hurricane Mk. I; bis zur Luftschlacht um England stieg die Zahl auf 30 Staffeln. Es ranken sich viele Heldengeschichten um die Hurricane-Staffeln und deren Piloten aus dieser Zeit, wobei jedoch auch deutlich wurde, daß die Leistungsfähigkeit der Hurricanes deutlich verbessert werden mußte. Der Einbau eines leistungsstärkeren Merlin-Motors führte zur Entwicklung der nur wenig längeren Hurricane Mk. IIA, die die Originalbewaffnung beibehielt, während die Mk. IIB mit jeweils zwei weiteren Maschinengewehren in jeder Tragfläche ausgerüstet wurde und mit insgesamt 12 Maschinengewehren eine eindrucksvolle Feuerkraft entwickelte. Gleichzeitig war jedoch auch die Bewaffnung der deutschen Jagdflugzeuge verbessert worden, so daß die mit Maschinengewehren ausgestatteten Hurricanes bald deutlich an Wirksamkeit verloren. Darüber hinaus trug auch die Einführung von durchschlagsstarker Kanonenbewaffnung auf beiden gegnerischen Seiten dazu bei, daß die Hurricanes der frühen Baureihen in eine untergeordnete Rolle bzw. in den Einsatz in Übersee abgedrängt wurden (die bauartähnliche Hurricane Mk. IIC war mit vier 20 mm Bordkanonen bestückt). Im Laufe des Jahres 1941 wurden auf dem RAF-Luftwaffenstützpunkt Duxford Versuche unternommen, Hurricanes Mk. IIB als Bomber einzusetzen. Die mit kanadischer Besatzung fliegende Staffel Nr. 402 war Pionier im Einsatz dieser Variante. Ihre "Hurribombers" flogen ihren ersten Angriff auf den Stützpunkt Berck-sur-Mur am 1. November desselben Jahres, wobei jede Maschine zwei 113-kg-Bomben abwarf. Die Staffel Nr. 602 setzte ihre Hurricane Mk. IIB zwischen März und August 1941 für Angriffe und Begleiteinsätze über dem Ärmelkanal ein, führten jedoch keine Einsätze als Bomber durch. Ihre Hurricane Mk. IIB wurden von einem 1.280 PS starken Rolls-Royce-Motor angetrieben (bzw. Merlin XXII mit 1.460 PS) und erreichte eine Maximalgeschwindigkeit von 544 km/h in 6.700 m Höhe. Die Bewaffnung bestand aus zwölf 7,7 mm Browning-Maschinengewehren, oder 10 MG's mit zusätzlich bis zu zwei 227 kg Bomben oder Treibstofftanks.

Hawker Hurricane Mk. II B

When performances of biplane fighters had reached their limits during the 1930s, more powerful and heavily armed monoplane were needed to replace them. Hawkers built a "Fury Monoplane", powered by the Rolls Royce Merlin engine; this new fighter became the legendary Hurricane, which first flew on 6 November 1935. The first production Mk.II flew in October 1937 and large orders were placed for the RAF, Hurricanes first entering service in 1937. At the outbreak of war in September 1939, RAF Fighter Command had 14 operational squadrons of the eight gun Hurricane Mk.IIs, this rising to 30 squadrons by the start of the Battle of Britain. There are many heroic stories of the Hurricane squadrons and their pilots during that period, which also revealed a need to considerably improve the Hurricane's performance. A more powerful Merlin engine led to the slightly longer Hurricane Mk.IIA, which retained the original armament, while the Mk. IIB had two extra guns installed in each wing giving a massive 12-gun firepower. At the same time the improved armour of German fighters soon rendered the machine gun equipped Hurricanes much less effective and introduction of the powerful cannon armament by both sides further relegated early machines to secondary or overseas roles; (the similar Hurricane IIC was armed with four 20mm cannons). During 1941, trials were carried out at RAF Duxford with Hurricane IIBs as bombers and the Canadian-crewed No. 402 Squadron pioneered this; its "Hurribombers" carried out their first attack on Berck-sur-Mur airfield on 1 November that year, each aircraft dropping two 113 kg bombs. No. 601 Squadron used their Hurricane Mk. IIBs on channel sweeps and escort duties between March and August 1941 but did not operate in the bombing role. Her Hurricane IIB was powered by a 1,280 hp Rolls Royce engine (or Merlin XXII rated at 1,460 hp) giving a maximum speed of 544 km/h (340 mph) at 6,700 m (22,000 ft). Armament consisted of twelve .303 in. Browning machine guns in the wings, or ten guns plus up to two 227 kg bombs or fuel tanks.

Furm hergestelt und im Eigentum von Revell GmbH & Co. KG. Widerschriftliche Nachahmungen werden gendertlich verpöht.
 Ce model a fost produs de la adresa Revell GmbH & Co. KG. Toate drepturile de copiere sunt rezervate. Orice alte versiuni sunt interzise.
 Modelado en propiedad de Revell GmbH & Co. KG. Imitaciones ilegales serán perseguidas por la ley.
 Kопия произведена по заказу Revell GmbH & Co. KG. и является его исключительной собственностью. Любые другие копии являются незаконными.
 Tutti i diritti sono riservati a Revell GmbH & Co. KG. Qualsiasi riproduzione non autorizzata è vietata.
 Forme et contenu réservés à Revell GmbH & Co. KG. Toute réimpression ou utilisation non autorisée sans la permission écrite de Revell GmbH & Co. KG. est formellement interdite. Toute réimpression ou utilisation non autorisée sans la permission écrite de Revell GmbH & Co. KG. est formellement interdite.
 Forme et contenu réservés à Revell GmbH & Co. KG. Toute réimpression ou utilisation non autorisée sans la permission écrite de Revell GmbH & Co. KG. est formellement interdite.

Ward manufactured by and property of Revell GmbH & Co. KG. All rights are reserved.
 Vorm vervaardigd door en eigendom van Revell GmbH & Co. KG. Drukovername of nabootsing zonder schriftelijke toestemming is strafbaar.
 Este produs de la e de productie de Revell GmbH & Co. KG. Toate drepturile sunt rezervate. Orice alte versiuni sunt interzise.
 Modelado en propiedad de Revell GmbH & Co. KG. Imitaciones ilegales serán perseguidas por la ley.
 Kопия произведена по заказу Revell GmbH & Co. KG. и является его исключительной собственностью. Любые другие копии являются незаконными.
 Tutti i diritti sono riservati a Revell GmbH & Co. KG. Qualsiasi riproduzione non autorizzata è vietata.
 Forme et contenu réservés à Revell GmbH & Co. KG. Toute réimpression ou utilisation non autorisée sans la permission écrite de Revell GmbH & Co. KG. est formellement interdite.
 Forme et contenu réservés à Revell GmbH & Co. KG. Toute réimpression ou utilisation non autorisée sans la permission écrite de Revell GmbH & Co. KG. est formellement interdite.

Benötigte Farben / Used Colors

Színnyelvi árnyalatok
Color shades

Färgnamn
Color name

Poljska naziv
Polish name

Dozovi nazivi
Color shade

Краски цвета
Color name

Базовые цвета
Basic colors

Potrzbne kalory
Required colors

Горелки краски
Paint colors

Szükséges színek
Required colors

A

- Dunkelgrün, matt 68
- Dark green, mat
- Vert foncé, mat
- Dunkelgrün, mat
- Verde oscuro, mate
- Verde oscuro, mate
- Verde scuro, opaco
- Mörkgrön, mat
- Tummivihreä, matta
- Mörkgrön, mat
- Mörkgrön, mat
- Темно-зеленый, матовый
- Ciemnozzielony, matowy
- Прозово оскоро, мат
- Koyu yeşil, mat
- Sötétzöld, matt
- Tmavozelená, matná
- Tmavozelena, brez leska

B

- blaugrau, matt 79
- (grey) blue matt
- (grey) blue, mat
- (grey) blue, mat
- (grey) blue, mat
- (grey) blue, mat
- (grey) blue, mat
- (grey) blue, mat
- (grey) blue, mat
- (grey) blue, mat
- (grey) blue, mat
- (grey) blue, mat
- (grey) blue, mat
- (grey) blue, mat
- (grey) blue, mat
- (grey) blue, mat
- (grey) blue, mat
- (grey) blue, mat
- (grey) blue, mat

C

- seegrün, matt 48
- (sea) green matt
- (sea) green, mat
- (sea) green, mat
- (sea) green, mat
- (sea) green, mat
- (sea) green, mat
- (sea) green, mat
- (sea) green, mat
- (sea) green, mat
- (sea) green, mat
- (sea) green, mat
- (sea) green, mat
- (sea) green, mat
- (sea) green, mat
- (sea) green, mat
- (sea) green, mat
- (sea) green, mat
- (sea) green, mat

10%

- grau, matt 57
- grey matt
- grey, mat
- grey, mat
- grey, mat
- grey, mat
- grey, mat
- grey, mat
- grey, mat
- grey, mat
- grey, mat
- grey, mat
- grey, mat
- grey, mat
- grey, mat
- grey, mat
- grey, mat
- grey, mat
- grey, mat

D

- grau, matt 57
- grey matt
- grey, mat
- grey, mat
- grey, mat
- grey, mat
- grey, mat
- grey, mat
- grey, mat
- grey, mat
- grey, mat
- grey, mat
- grey, mat
- grey, mat
- grey, mat
- grey, mat
- grey, mat
- grey, mat
- grey, mat

E

- gelb, matt 15
- yellow matt
- yellow, mat
- yellow, mat
- yellow, mat
- yellow, mat
- yellow, mat
- yellow, mat
- yellow, mat
- yellow, mat
- yellow, mat
- yellow, mat
- yellow, mat
- yellow, mat
- yellow, mat
- yellow, mat
- yellow, mat
- yellow, mat
- yellow, mat

F

- Himmelblau, matt 59
- sky blue, mat
- Bleu ciel, mat
- Himmelblau, mat
- Azul celeste, mate
- Azul celeste, mate
- Blu celeste, opaco
- Himmelblá, mat
- Taivaansininen, matta
- Himmelblá, mat
- Himmelblá, mat
- Hefeblo-голубой, матовый
- Błękitny, matowy
- Голубой, мат
- Gök mavisi, mat
- Égskínuleik, matt
- Azurová, matná
- Nebesnomodra, brez leska

G

- blau, matt 58
- blue matt
- blue, mat
- blue, mat
- blue, mat
- blue, mat
- blue, mat
- blue, mat
- blue, mat
- blue, mat
- blue, mat
- blue, mat
- blue, mat
- blue, mat
- blue, mat
- blue, mat
- blue, mat
- blue, mat
- blue, mat

H

- schwarz, matt 8
- black matt
- black, mat
- black, mat
- black, mat
- black, mat
- black, mat
- black, mat
- black, mat
- black, mat
- black, mat
- black, mat
- black, mat
- black, mat
- black, mat
- black, mat
- black, mat
- black, mat
- black, mat

I

- aluminium, metallik 89
- aluminium metallic
- aluminium metallic
- aluminium metallic
- aluminium metallic
- aluminium metallic
- aluminium metallic
- aluminium metallic
- aluminium metallic
- aluminium metallic
- aluminium metallic
- aluminium metallic
- aluminium metallic
- aluminium metallic
- aluminium metallic
- aluminium metallic
- aluminium metallic
- aluminium metallic
- aluminium metallic
- aluminium metallic

34%

- gelb, matt 15
- yellow matt
- yellow, mat
- yellow, mat
- yellow, mat
- yellow, mat
- yellow, mat
- yellow, mat
- yellow, mat
- yellow, mat
- yellow, mat
- yellow, mat
- yellow, mat
- yellow, mat
- yellow, mat
- yellow, mat
- yellow, mat
- yellow, mat
- yellow, mat

J

- seegrün, matt 48
- (sea) green matt
- (sea) green, mat
- (sea) green, mat
- (sea) green, mat
- (sea) green, mat
- (sea) green, mat
- (sea) green, mat
- (sea) green, mat
- (sea) green, mat
- (sea) green, mat
- (sea) green, mat
- (sea) green, mat
- (sea) green, mat
- (sea) green, mat
- (sea) green, mat
- (sea) green, mat
- (sea) green, mat
- (sea) green, mat

33%

- steingrau, matt 75
- stone grey matt
- stone grey, mat
- stone grey, mat
- stone grey, mat
- stone grey, mat
- stone grey, mat
- stone grey, mat
- stone grey, mat
- stone grey, mat
- stone grey, mat
- stone grey, mat
- stone grey, mat
- stone grey, mat
- stone grey, mat
- stone grey, mat
- stone grey, mat
- stone grey, mat
- stone grey, mat

65%

K

- lodergrün, matt 84
- (lo) green matt
- (lo) green, mat
- (lo) green, mat
- (lo) green, mat
- (lo) green, mat
- (lo) green, mat
- (lo) green, mat
- (lo) green, mat
- (lo) green, mat
- (lo) green, mat
- (lo) green, mat
- (lo) green, mat
- (lo) green, mat
- (lo) green, mat
- (lo) green, mat
- (lo) green, mat
- (lo) green, mat
- (lo) green, mat

35%

- aluminium, metallik 89
- aluminium metallic
- aluminium metallic
- aluminium metallic
- aluminium metallic
- aluminium metallic
- aluminium metallic
- aluminium metallic
- aluminium metallic
- aluminium metallic
- aluminium metallic
- aluminium metallic
- aluminium metallic
- aluminium metallic
- aluminium metallic
- aluminium metallic
- aluminium metallic
- aluminium metallic
- aluminium metallic
- aluminium metallic

L

- seegrün, matt 48
- (sea) green matt
- (sea) green, mat
- (sea) green, mat
- (sea) green, mat
- (sea) green, mat
- (sea) green, mat
- (sea) green, mat
- (sea) green, mat
- (sea) green, mat
- (sea) green, mat
- (sea) green, mat
- (sea) green, mat
- (sea) green, mat
- (sea) green, mat
- (sea) green, mat
- (sea) green, mat
- (sea) green, mat
- (sea) green, mat

M

- silber, metallik 80
- silver metallic
- silver metallic
- silver metallic
- silver metallic
- silver metallic
- silver metallic
- silver metallic
- silver metallic
- silver metallic
- silver metallic
- silver metallic
- silver metallic
- silver metallic
- silver metallic
- silver metallic
- silver metallic
- silver metallic
- silver metallic
- silver metallic

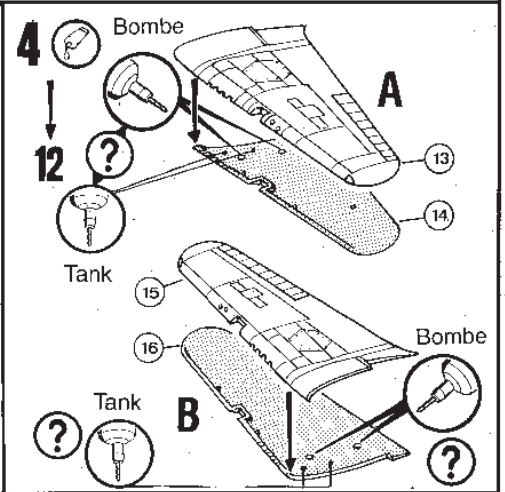
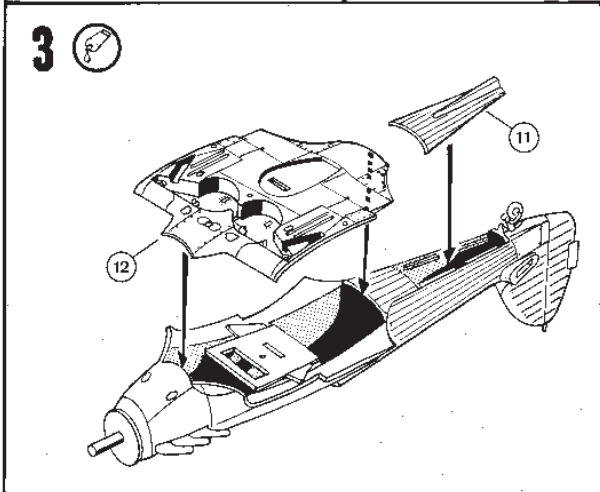
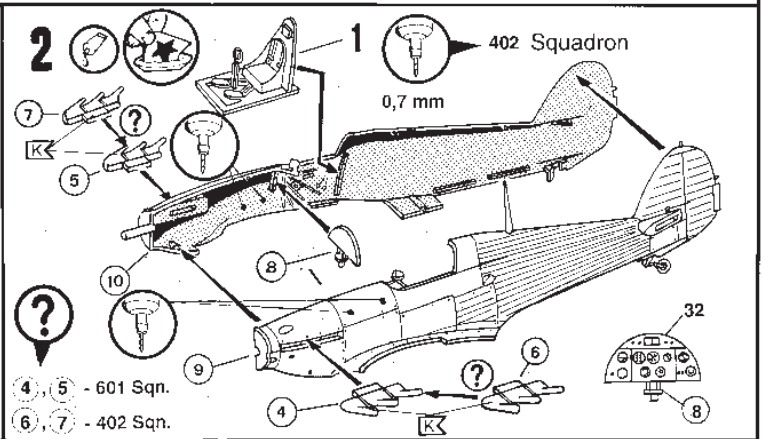
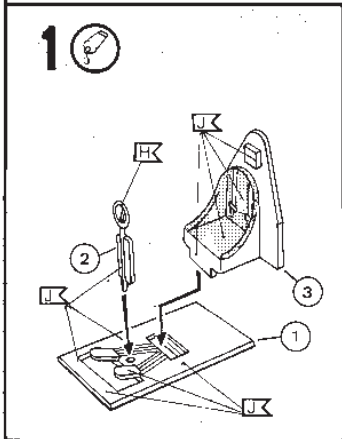
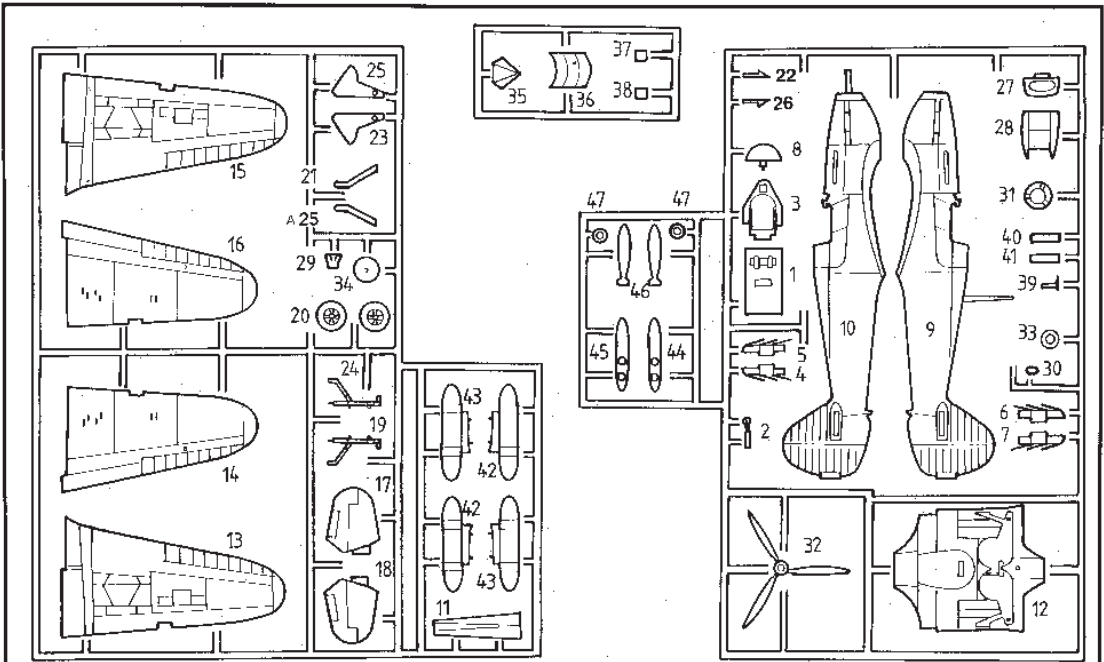

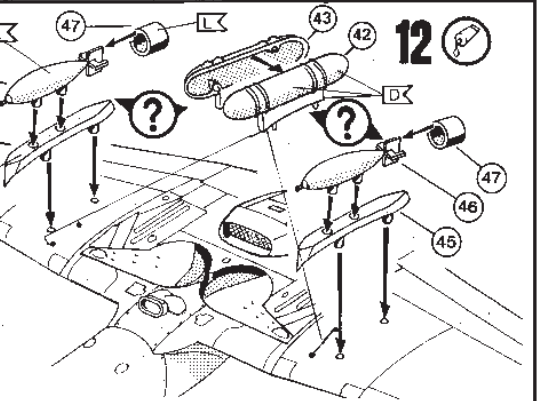
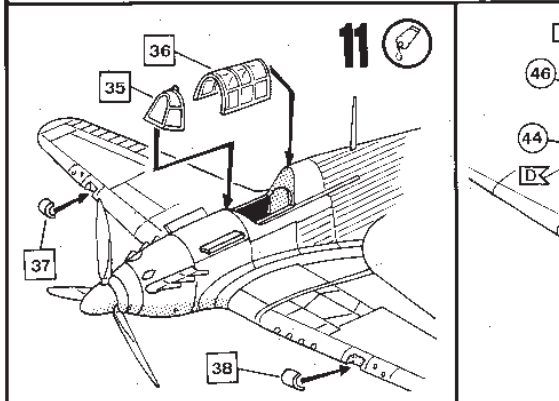
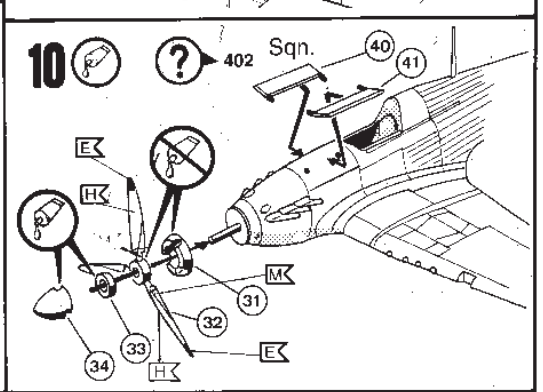
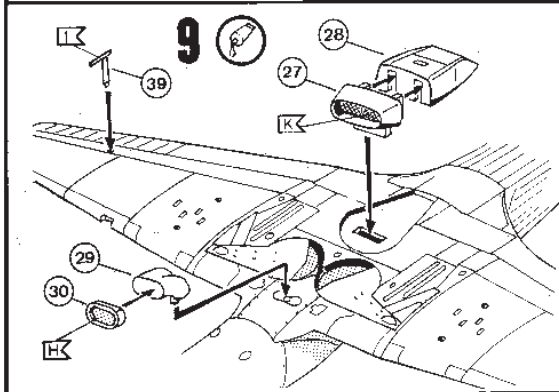
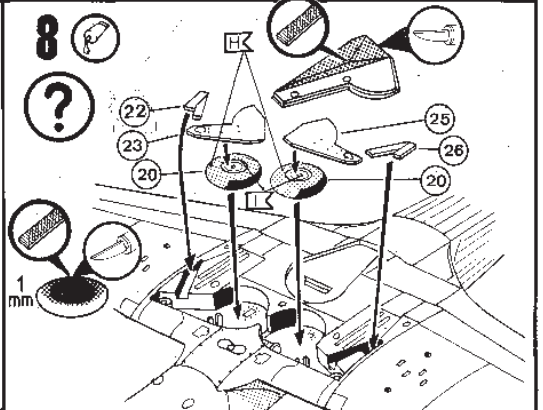
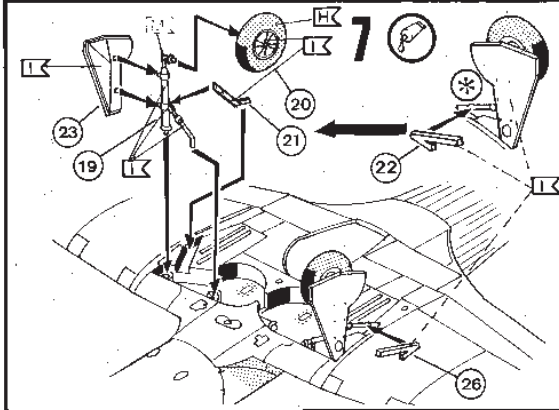
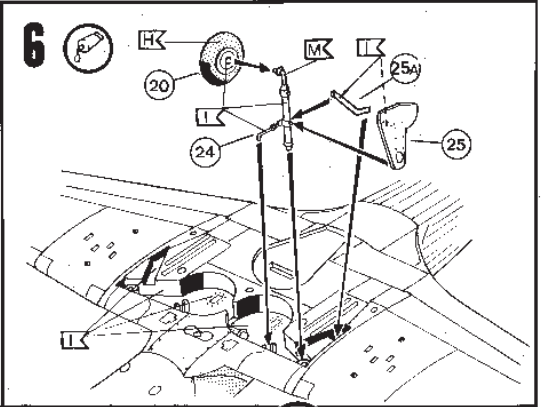
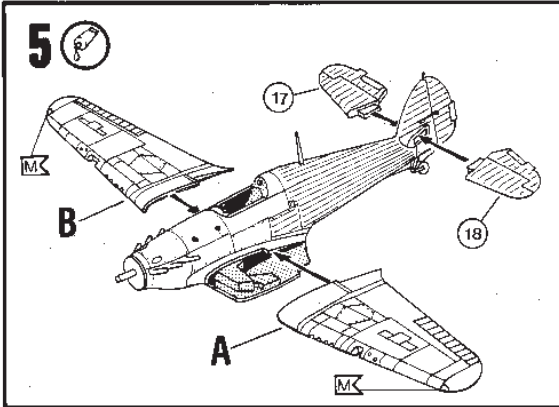

13



Hawker Hurricane Mk. II B, No. 601 (County of London) Squadron, Royal Auxiliary Air Force, Duxford, UK, August 1941.

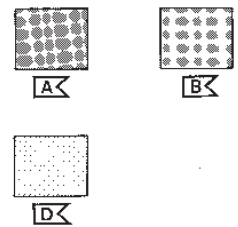
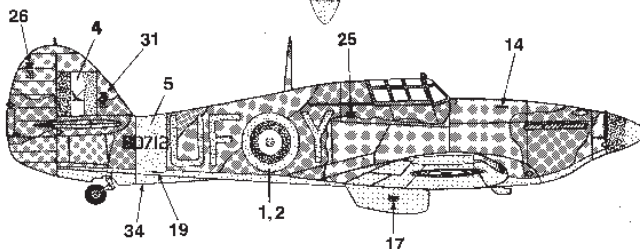
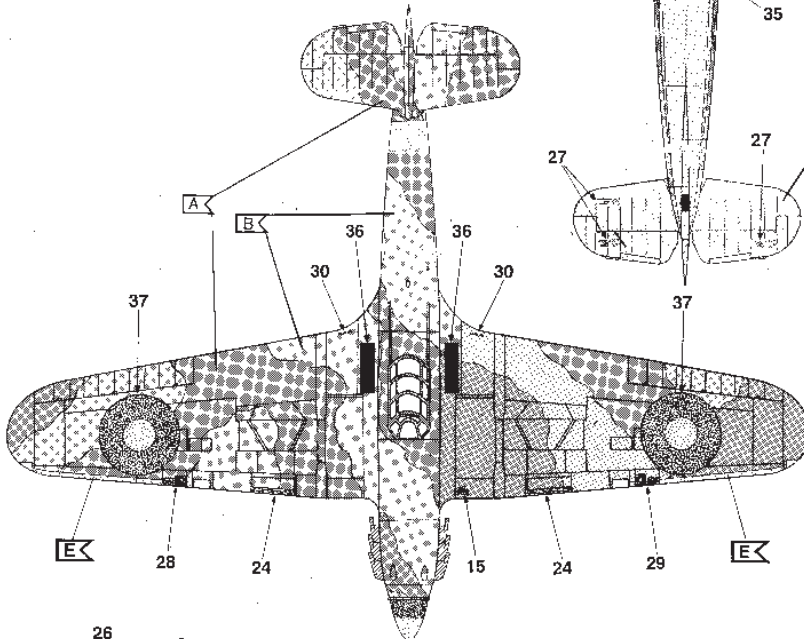
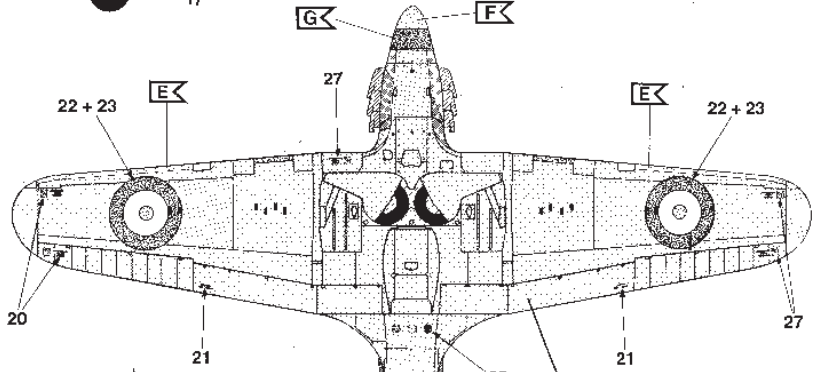
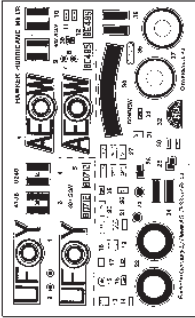
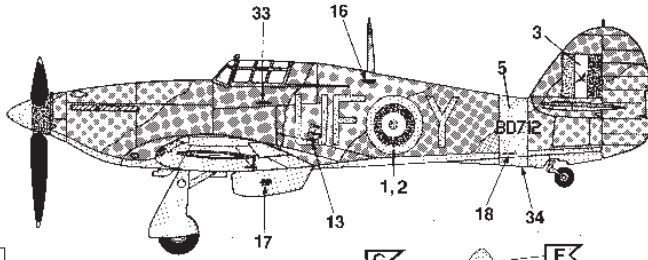

14



Hawker Hurricane Mk. II B, No. 402 (RCAF) Squadron, Royal Air Force, Warmwell, UK, November 1941.

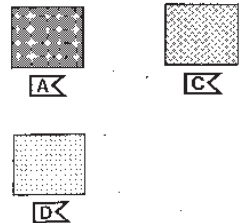
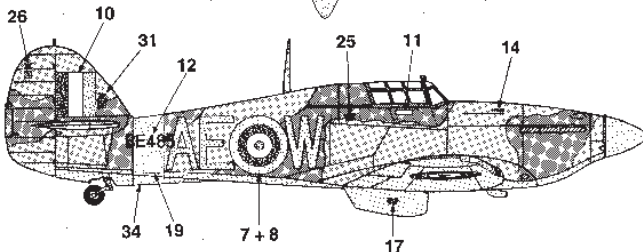
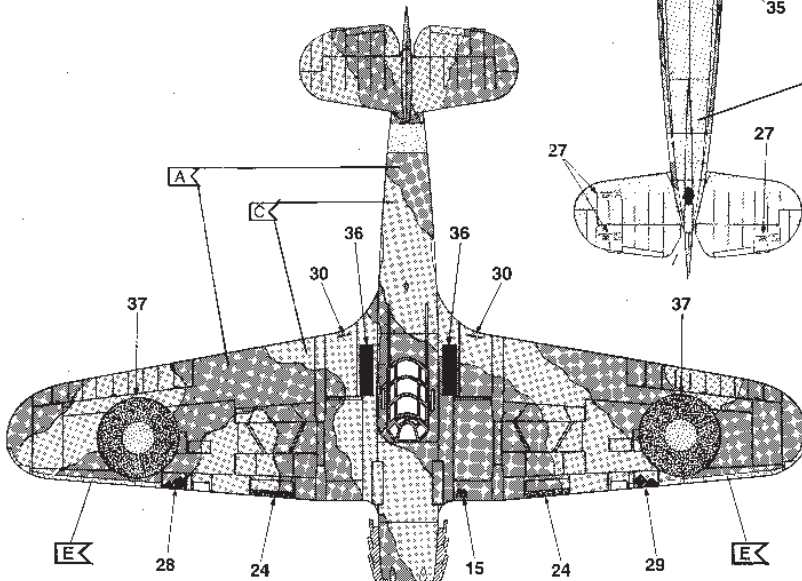
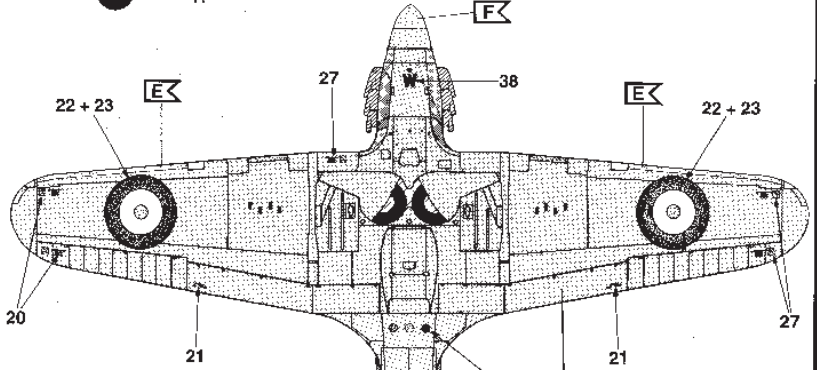
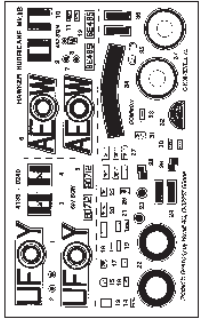
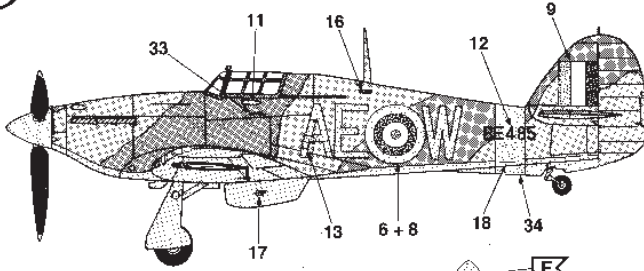



Supermarine Spitfire Mk V

A 04164 - 0389

©1996/2008 BY REVELL GmbH & Co. KG

PRINTED IN GERMANY



Benötigte Farben / Used Colors

Benötigte Farben Required colours	Peintures nécessaires Benodigde kleuren	Pinturas necesarias Tintas necessárias	Colori necessari Använda färger	Tarvittavat värit Du trenger følgende farger	Nødvendige farger Необходимые краски	Potrzebne kolory Απαιτούμενα χρώματα	Gerekti renkler Pot ebne barvy	Szükséges színek. Potrebne barve
--------------------------------------	--	---	------------------------------------	---	---	---	-----------------------------------	-------------------------------------

A

Dunkelgrün, matt 68
Dark green, matt
Vert foncé, mat
Donkergroen, mat
Verde oscuro, mate
Verde-escuro, mate
Verde scuro, opaco
Mörkgrön, matt
Tummanvihreä, matta
Merkegrön, mat
Mörkgrön, matt
Темно-зеленый, матовый
Ciemnozielony, matowy
Πράσινο σκούρο, ματ
Κοιυι yeşil, mat
Sötétzöld, matt
Tmavozelená, matná
Temnozelená, brez leska

B

blaugrau, matt 79
greyish blue, matt
gris-bleu, mat
blauwgrijs, mat
gris azulado, mate
cinzento azulado, fosco
grigio blu, opaco
blågrå, matt
siniharmaa, himmeä
blågrå, mat
blågrå, matt
сине-серый, матовый
siwy, matowy
γκριζομπλέ, ματ
Koyu yeşil, mat
modrošedá, matná
kékesszürke, matt
plavo siva, mat

C

Mittelgrau, matt 43
Medium grey, matt
Gris moyen, mat
Middelgrijs, mat
Gris medio, mate
Cinzento-médio, mate
Grigio medio, opaco
Mellangrå, matt
Keskiharmaa, matta
Mellengrå, mat
Mellomgrå, matt
Серый, матовый
Srednioszary, matowy
Γκρι μεσολό, ματ
Orta gri, mat
Középszürke, matt
Sifredné šedivá, matná
Srednjesiva, brez leska

D

Himmelblau, matt 59
Sky blue, matt
Bleu ciel, mat
Hemelsblauw, mat
Azul celeste, mate
Azul-celeste, mate
Blu celeste, opaco
Himmelsblå, matt
Taivaansininen, matta
Himmelblå, mat
Himmelblå, matt
Небесно-голубой, матовый
Blektinty, matowy
Γαλάζιο, ματ
Gök mavisi, mat
Egyszínék, matt
Azurová, matná
Nebesnomodra, brez leska

E

gelb, matt 15
yellow, matt
jaune, mat
geel, mat
amarillo, mate
amarelo, fosco
giallo, opaco
gul, matt
keltainen, himmeä
gul, mat
gul, matt
желтый, матовый
żółty, matowy
κίτρινο, ματ
sari, mat
žlutá, matná
sárga, matt
rumena, mat

F

grüngrau, matt 67
greenish grey, matt
gris vert, mat
groengrijs, mat
gris verdoso, mate
cinzento verde, fosco
grigio verde, opaco
gröngrå, matt
vihreänharmaa, himmeä
grangrå, mat
grangrå, matt
серо-зеленый, матовый
zielonoszary, matowy
γκριζοπράσινο, ματ
yeşil grişi, mat
zeleno edá, matná
zöldesszürke, matt
zeleno siva, mat

G

schwarz, matt 8
black, matt
noir, mat
zwart, mat
negro, mate
preto, fosco
nero, opaco
svart, matt
musta, himmeä
sort, mat
sort, matt
черный, матовый
czarny, matowy
μαύρο, ματ
siyah, mat
černá, matná
fekete, matt
črna, mat

H

steingrau, matt 75
stone grey, matt
gris pierre, mat
steengrijs, mat
gris pizarra, mate
cinzento pedra, fosco
grigio roccia, opaco
stengrå, matt
kivenharmaa, himmeä
stengrå, mat
steingrå, matt
серый каменный, матовый
szary kamien., matowy
γκρι πέτρας, ματ
taş grişi, mat
kamenně šedá, matná
kőszürke, matt
kamen siva, mat

Form hergestellt und im Eigentum von Revell GmbH & Co. KG. Widersrechtliche Nachahmungen werden gerichtlich verfolgt.
Ce produit est propriété de la société Revell GmbH & Co. KG. Toute utilisation ou duplication frauduleuse fera l'objet de poursuites en justice.
Modelado y en propiedad de Revell GmbH & Co. KG. Imitaciones ilícitas serán perseguidas por la ley.
Forma prodotta dalla Revell GmbH & Co. KG. e di proprietà della stessa impresa. La ovale proprietà è legalmente contro ogni imitazione abusiva.
Malli on Revell GmbH & Co. KG. valmistama ja omisuutta. Laittoaan kopiointiin tullaan puuttumaan oikeudellisin toimin.
Formen er produceret og eies av Revell GmbH & Co. KG. Efterligning uten tillatelse vil bli gjerand for rettslig forfølgelse.
Produkcia i prawo własności firmy Revell GmbH & Co. KG. Nielegalne podrobienie i jest zabronione pod oszczedziatnościami sądowa.
Model, Revell GmbH & Co. KG. firmasının mülkiyeti altında imal edilmiştir. Kanuna aykırı taklidi mahkemeye takip edilecektir.
A forma elebölőzője az a tulajdonjog bírósági a Revell GmbH & Co. KG. A jogellenes utánzatok és hamisításnyelk szőcsőgőg őőőőőő őőőőőő.

Model manufactured by and property of Revell GmbH & Co. KG. Illegal imitations are subject to prosecution.
Vorm vervaardigd door en eigendom van Revell GmbH & Co. KG. Onrechtmatige nabootsingen worden gerechtelijk vervolgd.
Formas produzidas e de propriedade da Revell GmbH & Co. KG. Cópias não autorizadas serão processadas judicialmente como determinadas na lei.
Modellen tillverkad av och tillhör Revell GmbH & Co. KG. All kopiering beivras enligt lagen om upphovsrätt.
Formen er fremstillet af Revell GmbH & Co. KG. som også har ejendomsret. Uloeglige efterligninger søgtes.
Modell valmistettu ja omistaa oikeuslaitos Revell GmbH & Co. KG. Protektio oikeuslaitos kysymykset ja syytösten vuoksi.
H model je proizvedena i je vlasništvo Revell GmbH & Co. KG. Nelegalne kopije bitoće pod pravno kaznjene.
Forma je proizvedena i je vlasništvo Revell GmbH & Co. KG. Neovlašćene kopije bitoće pravno kaznjene.

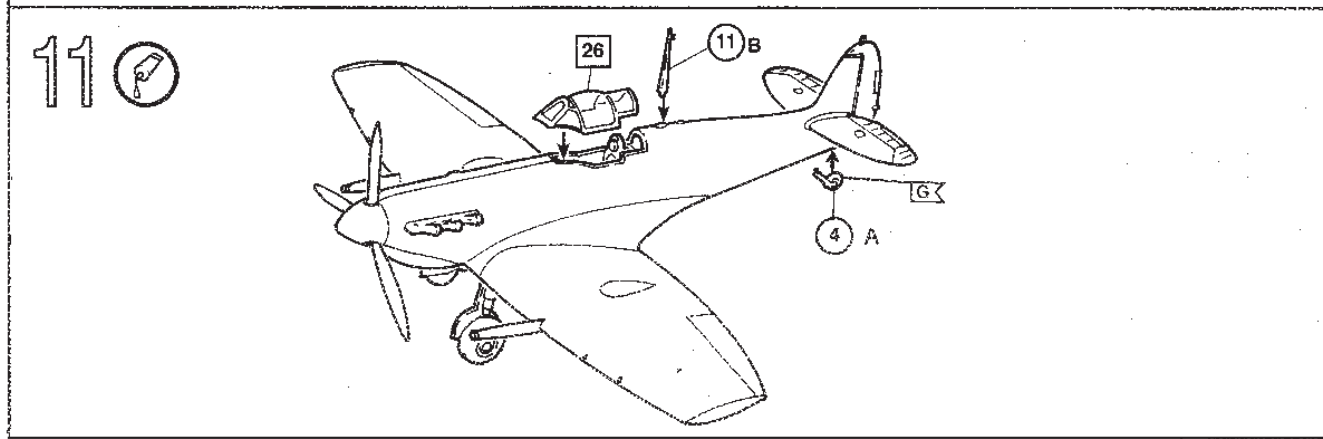
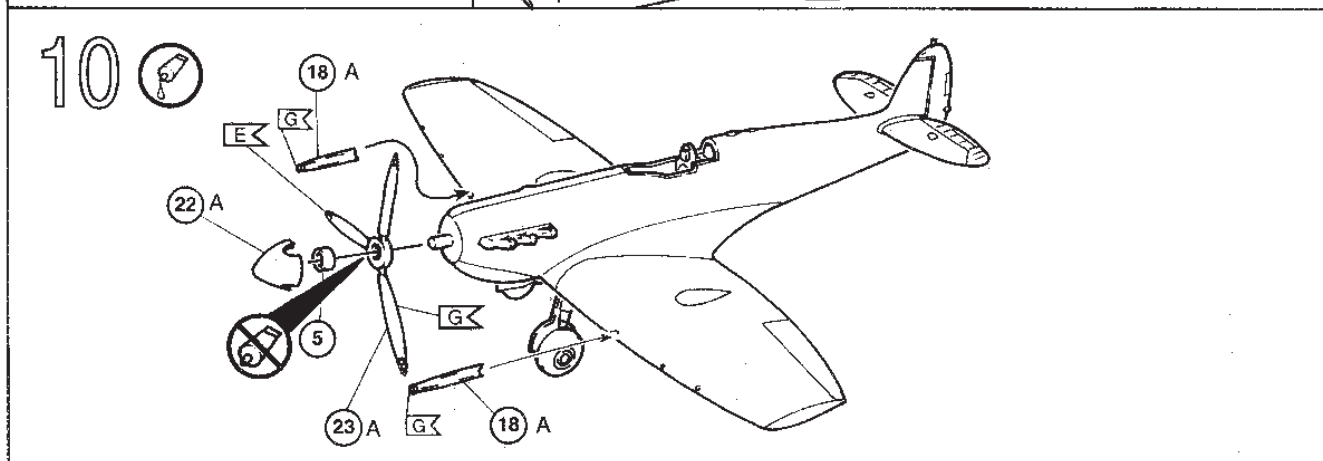
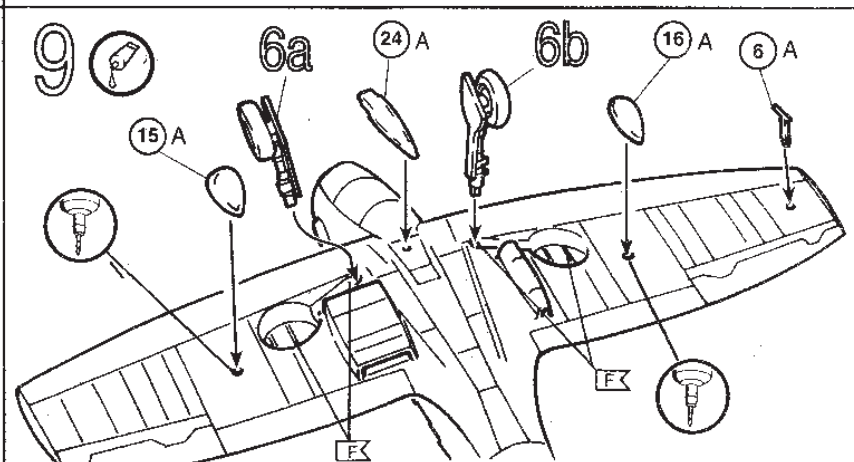
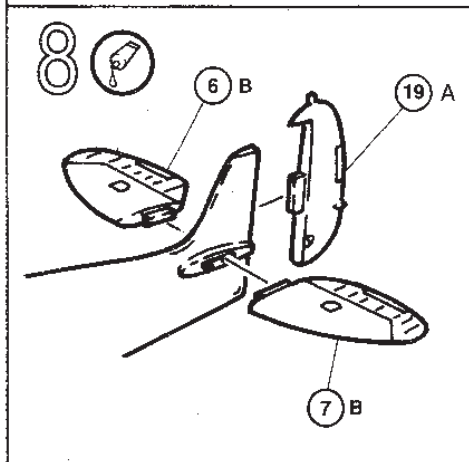
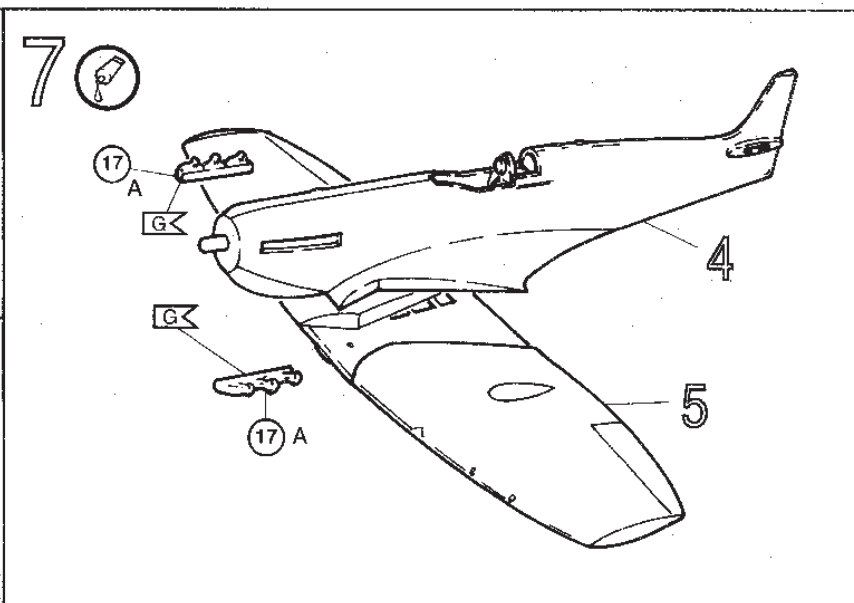
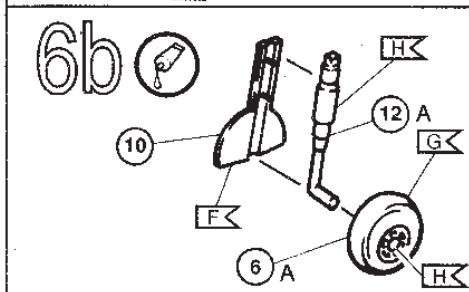
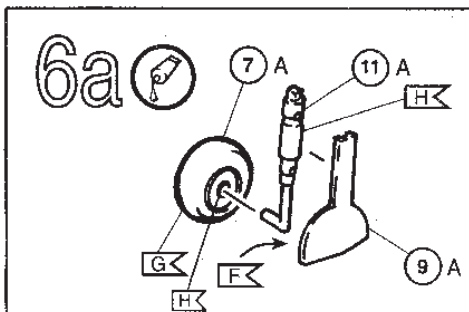

13 ?

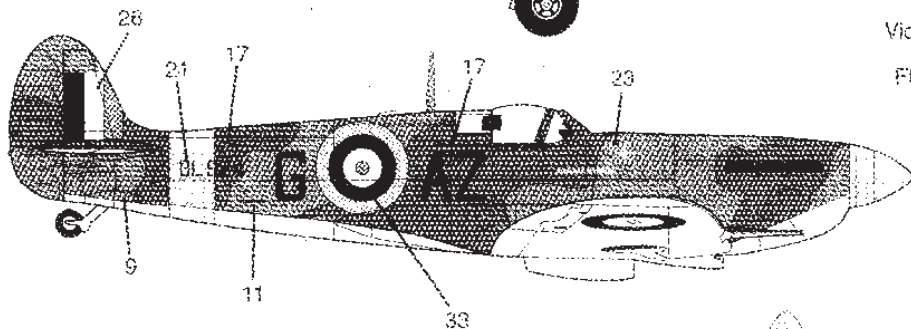
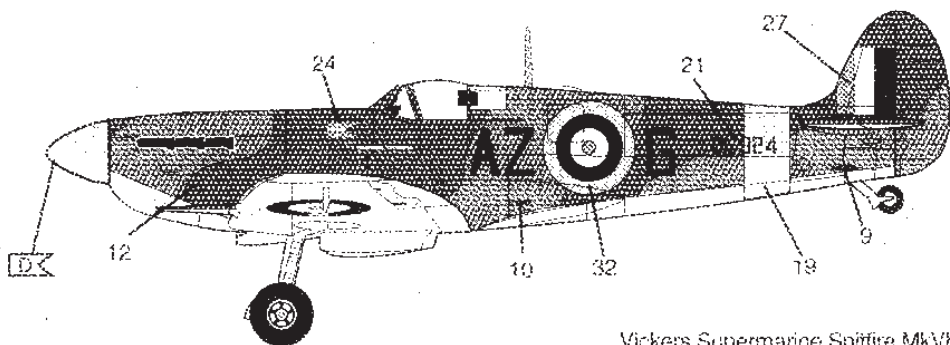

Vickers Supermarine Spitfire MkVb
 AZ-G 234 Sqn
 Flown by P/O Axel A. Svendsen
 Tangmere 1942

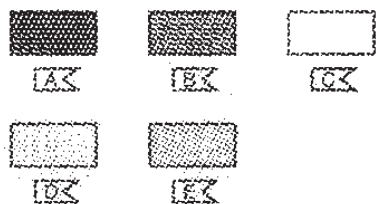
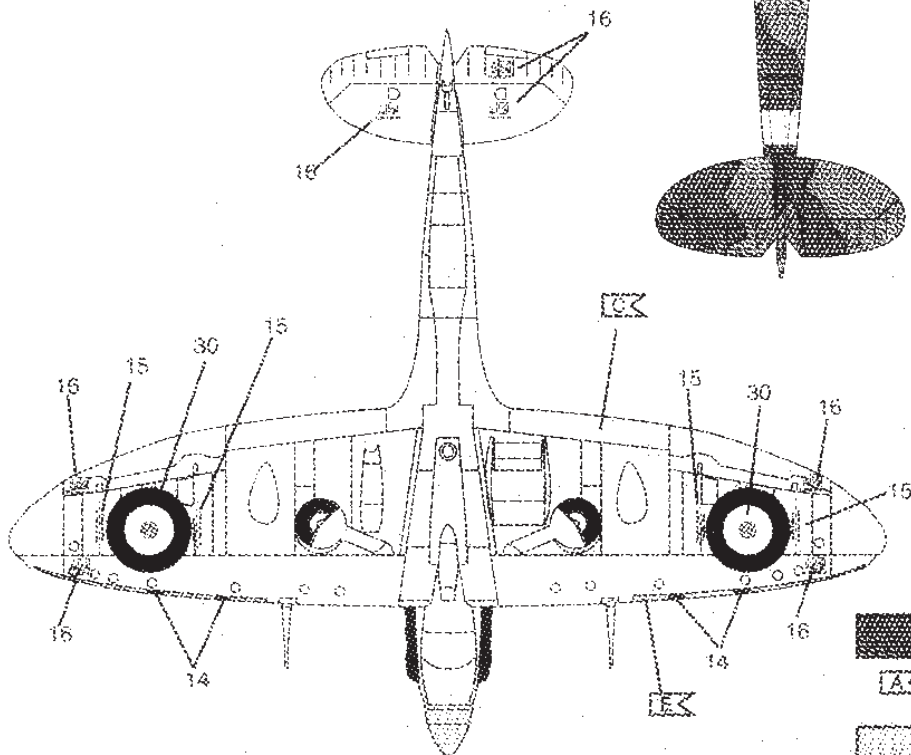
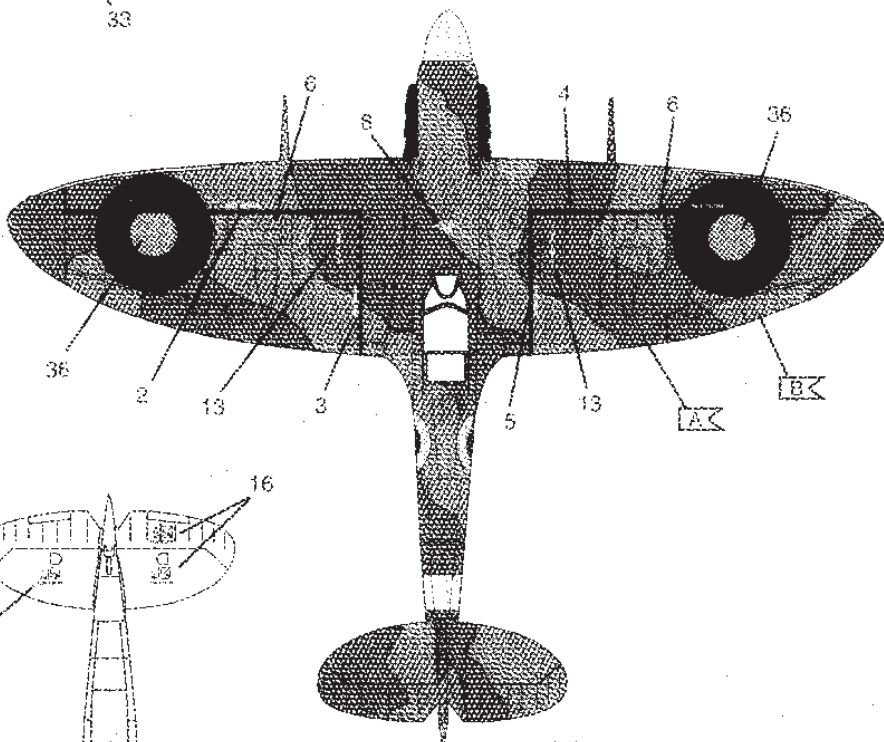



Avro Lancaster B.Mk. I / III

04300-0389

© 2007 BY REVELL GmbH & CO. KG

PRINTED IN GERMANY



Avro Lancaster B.Mk. I/III

Der viermotorige Bomber Avro Lancaster des Typs 683 war der Nachfolger des erfolglosen zweimotorigen Bombers Avro Manchester, dessen Vulture-Motoren sich als unzuverlässig und leistungsschwach erwiesen hatten. Obwohl die Manchester ab 1940 für einen kurzen Zeitraum bei der RAF Bomber Command in Dienst gestellt war, erteilte das Air Ministry schon im Juli desselben Jahres mit der Spezifikation B1/39 den Auftrag für einen schweren viermotorigen Bomber mit einer Waffenlast von 4.356 kg (10.000 lb) und einer Reichweite von 4.023 km (2.500 Meilen). Außerdem sollte dieser Bomber eine Geschwindigkeit von 450 km/h (280 mph) auf 4.572 m Höhe (15.000ft.) haben. Der leitende Designer bei Avro, Roy Chadwick, und sein Team entschlossen sich bald, die Manchester abzuändern, um die Vorgaben der Spezifikation zu erfüllen. Nach einigen strukturellen Veränderungen und einer Vergrößerung der Spannweite entstand der Prototyp der Lancaster, der mit Rolls Royce-Triebwerken des Typs Merlin X ausgestattet war und der am 9. Januar 1941 zum ersten Mal flog. Der zweite Prototyp, in den Motoren des Typs Merlin XX eingebaut wurden, entsprach im Grunde bereits den Standards der Serienfertigung des Typs B.Mk.I. Die Serienmaschinen des Typs B.I erhielten später Merlin 22- und Merlin 24-Motoren sowie den D.H. (De Havilland) oder Hamilton Standard Drei-Blatt-Propeller. Der dritte Prototyp, der für die Version B.Mk.II gebaut wurde, wurde von vier Bristol Hercules Mk. VI Sternmotoren angetrieben und flog zum ersten Mal am 26. November 1941. Zu diesem Zeitpunkt hatte bereits die erste Maschine der Version B.Mk.I aus Serienproduktion ihren Erstflug absolviert. Die Produktion ging zügig voran, und so wurden die ersten drei Maschinen des Typs B.I bereits am 24. Dezember 1941 an die No. 44 Squadron ausgeliefert. Um jegliche Produktionsprobleme mit den britischen Rolls Royce Merlin-Motoren auszuschalten, wurden in großen Stückzahlen Motoren der Typen 28, 38 und 224 bereit gestellt, die von der US-amerikanischen Firma Packard gebaut wurden. Der Einbau dieser Motoren führte zur Version Lancaster B.Mk.III; ansonsten aber war diese Version identisch mit der B.I. Im weiteren Verlauf des Zweiten Weltkriegs wurde die Ausstattung mehrfach abgeändert, wobei eine der äußerlich auffälligsten Veränderungen an vielen Flugzeugen die an der Rumpfunterseite angebrachte Verkleidung für das H2S Bodenradar war; außerdem gab es u.a. verschiedene fortschrittliche Navigationshilfen und Abwehrmaßnahmen gegen Radarerfassung. Eine Methode bestand dabei darin, so genanntes „Window“ (in Deutschland als „Düppel“ bezeichnet) abzuwerfen. Hierbei handelte es sich um tausende von schmalen Stanniolpapierstreifen, die die Zielerfassung der feindlichen Radarschirme störten. Abgeworfen wurde es mittels einer einfachen Rutsche, die bei vielen Lancaster unter der Nase angebracht war. Viele Lancaster-Maschinen wurden für spezielle Einsätze umgebaut, oder auch um schwerere Waffentypen mitführen zu können. Bis 1945 wurden insgesamt 68 Einsatzstaffeln (Squadrons) der Bomber Command (einschließlich vieler Einheiten des britischen Commonwealth und weiterer alliierter Kräfte) gebildet, von denen bis Kriegsende zusammen gerechnet mehr als 156.000 Kampfeinsätze geflogen wurden. Die Verluste an Lancaster und ihren Besatzungen waren hoch: von 7.377 gebauten Maschinen wurden 3.814 bei Einsätzen und durch Unfälle zerstört. Gegen Ende des Kriegs, als die Anzahl der deutschen Jagdgeschwader rapide sank, wurde eine höhere Anzahl von Einsätzen gegen hochwertige Ziele bei Tage geflogen, z.B. gegen Hitlers Versteck in Berchtesgaden, gegen das deutsche Schlachtschiff Tirpitz und die Produktionsstätten von V-Waffen. Viele Flugzeuge des Typs Lancaster blieben bei der RAF und anderen Luftwaffen bis in die 1950er Jahre hinein im Einsatz. Die Besatzung umfasste sieben Personen. Die Höchstgeschwindigkeit der Lancaster betrug bei voller Beladung 443 km/h (275mph) auf 4.572m (15.000ft.) Höhe. Spannweite: 31,10m (102ft.), Länge: 21,18m (69ft. 6in.), Höhe: 6,25m (20ft 6in.).

Avro Lancaster B.Mk. I/III

The four-engined Avro Type 683 Lancaster bomber was born as a result of the failed twin-engined Avro Manchester bomber, the Vulture engines of which lacked reliability and power. Although the Manchester served briefly with RAF Bomber Command from 1940, in July that year the Air Ministry issued Specification B1/39 for a four engined heavy bomber capable of carrying a 4,356kg (10,000 lb) weapons load for a range of 4,023km (2,500 miles); it also needed to be capable of 450km/h (280mph) at an altitude of 4,572m (15,000ft). Avro's chief designer, Roy Chadwick and his team quickly looked at modifying the Manchester to meet this specification. Some structural changes and an increased wing span led to the prototype Lancaster, which was fitted with Rolls Royce Merlin X engines and first flew on 9 January 1941. The second prototype, powered by Merlin XX engines, was virtually to B.Mk.I production standards; later on Merlin 22 and 24 engines were fitted to production B.I.s, using D.H. or Hamilton Standard three bladed propellers. The third prototype, for the B.Mk.II, was powered by four Bristol Hercules Mk.VI radial engines and first flew on 26 November 1941, by which time the first production B.Mk.I had also flown. Production was rapid, with the first three B.I.s being delivered to No.44 Squadron on 24 December 1941. To overcome any production problems with British Rolls Royce Merlin engines, American Packard-built Merlin 28, 38 and 224 engines were provided in large numbers, fitment of these resulting in the Lancaster B.Mk.III; otherwise this version was identical to the B.I. As the war progressed, many equipment modifications were introduced, one of the most noticeable externally on many aircraft being the prominent ventral housing for the H2S ground mapping radar scanner; others included various advanced navigational aids and radio/radar countermeasures. One method of disrupting enemy radars was the dropping of 'window', which consisted of thousands of thin metallic paper strips which disrupted the view shown on enemy radar screens; this 'window' was dispensed through a simple chute fitted under the noses of many Lancasters. Many Lancasters were modified for specialised raids or for delivering heavier types of weapons. A total of 68 operational Bomber Command squadrons (including many British Commonwealth and other allied units) had formed by 1945; between them more than 156,000 sorties were flown up to the end of the war. A heavy toll was taken of the Lancasters and their crews, for out of 7,377 built 3,814 were lost on operations and through accidents. Towards the end of the war, with the rapid depletion of German fighter forces, an increasing number of daylight missions were flown against high value targets, examples being Hitler's hideout at Berchtesgaden, the German pocket battleship Tirpitz and the V-weapons sites. Many Lancasters continued in service with the RAF and other air forces into the 1950s. Carrying a crew of seven, the Lancaster had a maximum speed with full load of 443km/h (275mph) at 4,572m (15,000ft). Wing span: 31.10m (102ft). Length: 21.18m (69ft 6in.) Height: 6.25m (20ft 6in.)

Forst hergestellt und im Eigentum von Revell GmbH & Co. KG. Wiederechtliche Nachahmungen werden gerichtlich verfolgt.
 Ce produit est propriété de la société Revell GmbH & Co. KG. Toute utilisation ou duplication frauduleuse sera poursuivie en justice.
 Modelado y en propiedad de Revell GmbH & Co. KG. Imitaciones ilícitas serán perseguidas por la ley.
 Forma prodotta da la Revell GmbH & Co. KG. e d' proprietà della stessa impresa, la quale procederà legalmente contro ogni imitazione abusiva.
 Malli on Revell GmbH & Co. KG. valmistama ja omisuust. Laittoaan kopioitain tuliaan puuttamaan oikeudellisin toimin.
 Formen er produceret og eies av Revell GmbH & Co. KG. Efterligning eller tilfælde vil bli gjerdet for rettlig forfølgelse.
 Produkcja i prawa własności firmy Revell GmbH & Co. KG. Niezgodnie podrobienie jest zabronione pod odpowiedzialnością sądową.
 Model Revell GmbH & Co. KG. firmasının mülkiyetinde olduğu ve imalatıdır. Kanuna aykırı taklidi mahkemeye takip edilecektir.
 A forma előállításja és a tulajdonjog círszékese a Revell GmbH & Co. KG. A jogellenes utánzatok: és hamisítványoktat bíróságiag üldözék, y üldözök.

Mould manufactured by and property of Revell GmbH & Co. KG. Illegal imitations are subject to prosecution.
 Vorm vervaardigd door en eigendom van Revell GmbH & Co. KG. Onrechtmatige nabootsingën worden gerechtelijk vervolgd.
 Formas produzidas e de propriedade da Revell GmbH & Co. KG. Cópias não autorizadas serão processadas, unicamente como determinadas na lei.
 Modellen tillverkad av och tillhör Revell GmbH & Co. KG. All kopiering beivras enligt lagen om upphovsrätt.
 Formen er framstillet af Revell GmbH & Co. KG. som også har ejendommen. Lovstridige efterligninger søgtes.
 Modeli su proizvedeni u vlasnosti firme Revell GmbH & Co. KG. Proizvodionice poduzimaju pravne postupke u slučaju kopiranja.
 Forme by wyprodukowane i w posiadaniu firmy Revell GmbH & Co. KG. Niezgodnie z prawem powielanie i rozpowszechnianie bez zgody właściciela będzie postępowane zgodnie z prawem.
 Forma je proizvedena in je v lastništvo Revell GmbH & Co. KG. Neovoblašene kopije bodo pravno kaznjene.

Benötigte Farben / Used Colors

Benötigte Farben
Required colours

Peintures nécessaires
Benötigte kleuren

Pinturas necesarias
Tintas necessárias

Colori necessari
Arvândade färger

Tarvittavat värit
Du trenger følgende färger

Nødvendige farger
Необходимые краски

Potrebne kolory
Απαιτούμενα χρώματα

Gerekli renkler
Potrebne barvy

Szükséges színek.
Potrebne barve

A

Dunkelgrün, matt 68
Dark green, matt
Vert foncé, mat
Donkergroen, mat
Verde oscuro, mate
Verde-escuro, mate
Verde scuro, opaco
Mörkgrön, matt
Tummanvihreä, matta
Mörkgrön, mat
Mörkgrön, matt
Темно-зеленый, матовый
Ciemnozielony, matowy
Πράσινο σκούρο, ματ
Koyu yeşil, mat
Sötétzöld, matt
Tmavozelena, matná
Temnozelená, brez leska

B

Erde dunkel, matt 82
Dark earth, matt
Terre foncée, mat
Donkeraarokleurig, mat
Color tierra oscuro, mate
Terra-escuro, mate
Terra scura, opaco
Jord mörk, matt
Mullanruskea, matta
Mörk jord, mat
Jord mörk, matt
Темный земляной, матовый
Ciemnoziemny, matowy
Γήινο σκούρο, ματ
Toprak koyu, mat
Földszínű, matt
Zemitě tmavá, matná
Prstena temna, brez leska

C

95 % schwarz, matt 8
black, matt
noir, mat
zwart, mat
negro, mate
preto, fosco
nero, opaco
svart, matt
musta, himmeä
sort, mat
sort, matt
черный, матовый
czarny, matowy
μαύρο, ματ
siyah, mat
černá, matná
fekete, matt
črna, matt

+ Hellgrau, matt 76
Light grey, matt
Gris clair, mat
Lichtgrijs, mat
Gris claro, mate
Cinzento-claro, mate
Grigio chiaro, opaco
Ljusgrå, matt
Vaaleanharmaa, matta
Lysegrå, mat
Lysegrå, matt
Светло-серый, матовый
Jasnoszary, matowy
Γκρι ανοιχτό, ματ
Açık gri, mat
Világosszürke, matt
Svètle šedivá, matná
Svetlosiva, brez leska

D

gelb, matt 15
yellow, matt
jaune, mat
geel, mat
amarillo, mate
giallo, opaco
gul, matt
keltainen, himmeä
gul, mat
gul, matt
желтый, матовый
żółty, matowy
κίτρινο, ματ
sari, mat
Žlutá, matná
sárga, matt
rumena, mat

E

weiß, matt 5
white, matt
blanc, mat
wit, mat
branco, fosco
bianco, opaco
vit, matt
valkoinen, himmeä
hvid, matt
hvit, matt
белый, матовый
biały, matowy
λευκό, ματ
beyaz, mat
biła, matná
fehér, matt
bela, mat

F

70 % seegrün, matt 48
sea green, matt
vert d'eau, mat
zeegroen, mat
verde-mar, mate
verde lago, opaco
havsgrön, matt
merenvihreä, himmeä
havgrön, mat
sjögrön, matt
зеленый морской, матовый
zieleń morská, matowy
πράσινο λιμνής, ματ
göl yeşili, mat
mořská zelená, matná
tengerzöld, matt
morsko zelena, mat

G

30 % Hellgrau, matt 76
Light grey, matt
Gris clair, mat
Lichtgrijs, mat
Gris claro, mate
Cinzento-claro, mate
Grigio chiaro, opaco
Ljusgrå, matt
Vaaleanharmaa, matta
Lysegrå, mat
Lysegrå, matt
Светло-серый, матовый
Jasnoszary, matowy
Γκρι ανοιχτό, ματ
Açık gri, mat
Világosszürke, matt
Svètle šedivá, matná
Svetlosiva, brez leska

G

braun, matt 85
brown, matt
brun, mat
bruin, mat
marrón, mate
castanho, fosco
marrone, opaco
bruin, matt
ruskea, himmeä
bruin, mat
bruin, matt
коричневый, матовый
brązowy, matowy
καφέ, ματ
kahverengi, mat
hnědá, matná
barna, matt
rjava, mat

H

khakibraun, matt 86
olive brown, matt
brun khaki, mat
khakibraun, mat
caqui, mate
castanho caqui, fosco
marrone caqui, opaco
kaki-brun, matt
khakiruskea, himmeä
khakibraun, mat
khakibraun, matt
коричневый "хаки", матовый
brązowy khaki, matowy
καφε-χάκι, ματ
häki renkli, mat
hnědá khaki, matná
kekibarna, matt
kaki rjava, mat

I

aluminium, metallic 99
aluminium, metallic
aluminium, métallique
aluminium, metallic
aluminio, metalizado
alumínio, metálico
aluminio, metalico
aluminium, metallic
aluminium, metallikiitto
aluminium, metallik
aluminium, metallic
aluminium, metallik
алюминиевый, металл
aluminium, metaliczny
αλουμίνιου, μεταλλικό
aluminium, metallik
aluminium, metall
aluminium, metallik

J

25 % eisen, metallic 91
steel, metallic
coloris fer, métallique
ijzerkleurig, metallic
ferroso, metalizado
ferro, metálico
ferro, metalico
järnårg, metallic
teräksenvärinen, metallikiitto
jern, metallik
jern, metallic
стальной, металл
żelazo, metaliczny
σιδηρού, μεταλλικό
demir, metallik
železná, metaliza
vas, metáll
železna, metallik

+ rost, matt 83
rust, matt
rouille, mat
roest, mat
orin, mate
ferrugem, fosco
color ruggine, opaco
rost, matt
ruoste, himmeä
rust, mat
rust, matt
ржавчина, матовый
rdzawy, matowy
χρώμα σκουριάς, ματ
pas rengi, mat
rezavá, matná
rozsdá, matt
rjava, mat

75 %**K**

33 % Dunkelgrün, matt 39
Dark green, matt
Vert foncé, mat
Donkergroen, mat
Verde oscuro, mate
Verde-escuro, mate
Verde scuro, opaco
Mörkgrön, matt
Tummanvihreä, matta
Mörkgrön, mat
Mörkgrön, matt
Темно-зеленый, матовый
Ciemnozielony, matowy
Πράσινο σκούρο, ματ
Koyu yeşil, mat
Sötétzöld, matt
Tmavomodrá, matná
Temnozelená, brez leska

67 %

khakibraun, matt 86
olive brown, matt
brun khaki, mat
khakibraun, mat
caqui, mate
castanho caqui, fosco
marrone caqui, opaco
kaki-brun, matt
khakiruskea, himmeä
khakibraun, mat
khakibraun, matt
коричневый "хаки", матовый
brązowy khaki, matowy
καφε-χάκι, ματ
häki renkli, mat
hnědá khaki, matná
kekibarna, matt
kaki rjava, mat

L

anthrazit, matt 9
anthracite grey, matt
anthracite, mat
khakibraun, mat
antracita, mate
antracite, fosco
antracite, opaco
antracit, matt
antracitti, himmeä
koksgrå, mat
antrasit, matt
антрацит, матовый
antracyt, matowy
ανθρακί, ματ
antrasit, mat
antracit, matná
antracit, matt
tanmo siva, matt

M

silber, metallic 90
silver, metallic
argent, métallique
zilver, metallic
plata, metalizado
prata, metálico
argento, metalico
silver, metallic
hopea, metallikiitto
solv, metallik
solv, metallic
серебристый, металл
srebro, metaliczny
σημί, μεταλλικό
gümüş, metallik
stříbrná, metaliza
ezüst, metáll
srebrna, metallik



Schwarzen Faden benutzen
Use black thread
Employer le fil noir
Gebruik zwarte draad
Utilizar hilo color negro
Utilizar fio preto
Usare filo nero
Använd svart tråd
Käytä mustaa lankaa
Benyt en sort
Bruk svart
Использовать черные нитки
Użyć czarnej nici
χρησιμοποιήστε την καφέ μάλλινη
Kahverengi siyah iplik kullanın
Použit černé vlákno
Barna fekete fonalat kell használni
Uparabljati črni nit

Nicht enthalten
Not included
Non fourni
Behoort niet tot de levering
No incluido
Non compresi
Não incluído
Ikke medsendt
Ingår ej
Ikke inkluderet
Eivät sisälly
Δεν συμπεριλαμβάνεται
Не содержится
Nem tartalmazza
Nie zawiera
Ni vsebovano
İçerisinde bulunmamaktadır
Neni obsaženo



Nicht benötigte Teile
Parts not used
Pièces non utilisées
Niet benodigde onderdelen
Piezas no necesarias
Peças não utilizadas
Parti non usate
Inte använda delar
Tarpeettomat osat
Ikke nødvendige dele
Deler som ikke er nødvendige
Неиспользованные детали
Elementy niepotrzebne
μη χρησιμοποιούμενα εξαρτήματα
Gereksiz parçalar
Nepotřebné díly
fei nem használt alkatrészek
Nepotrebni deli

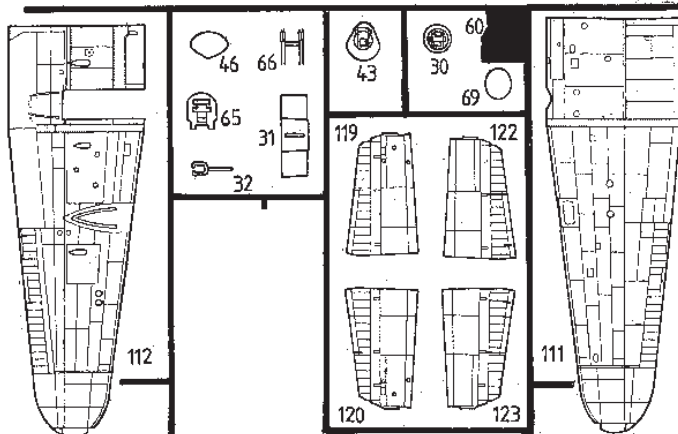
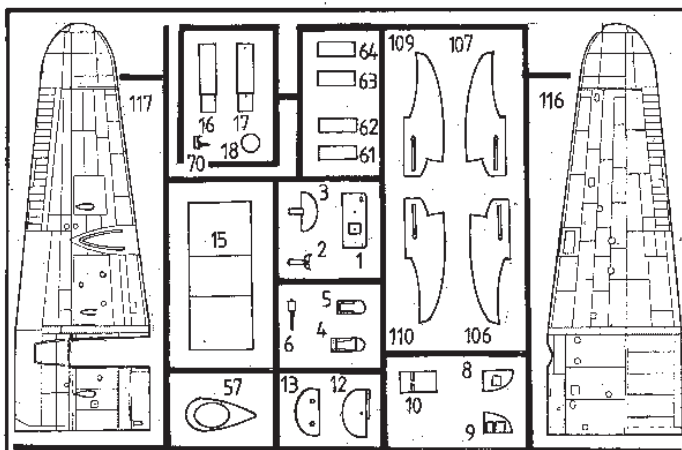

2X

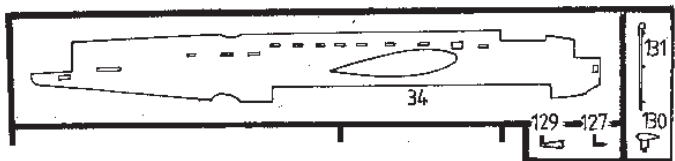
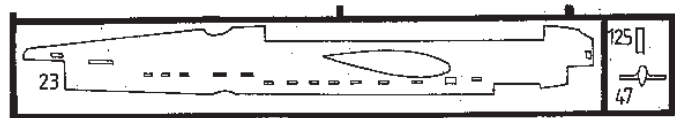
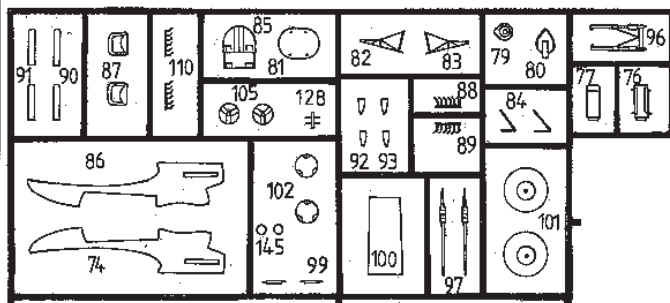

2X

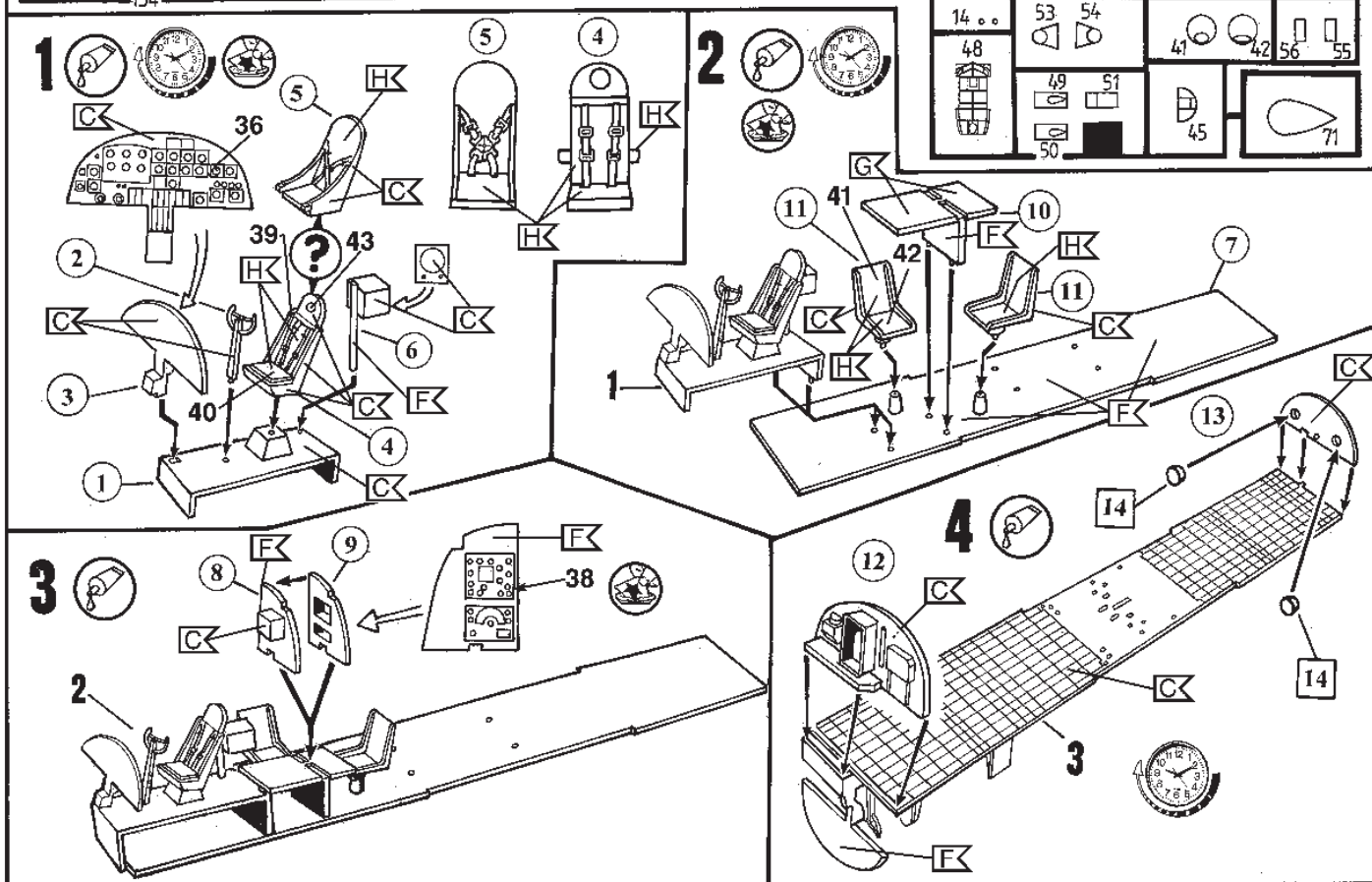
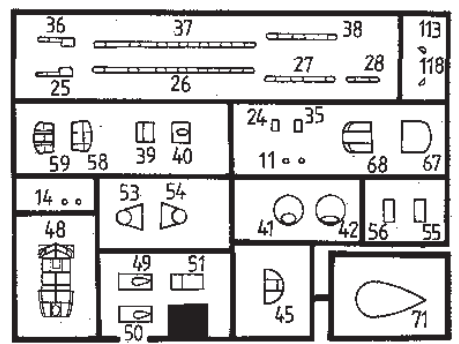
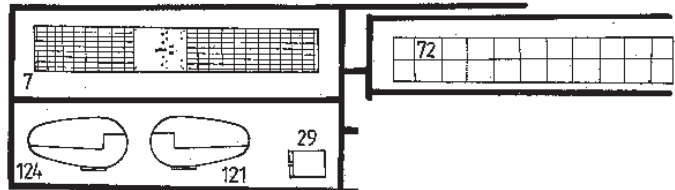
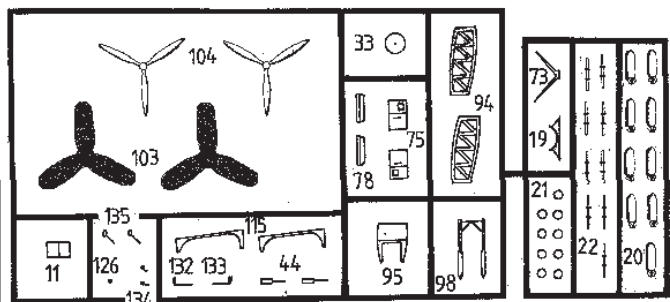

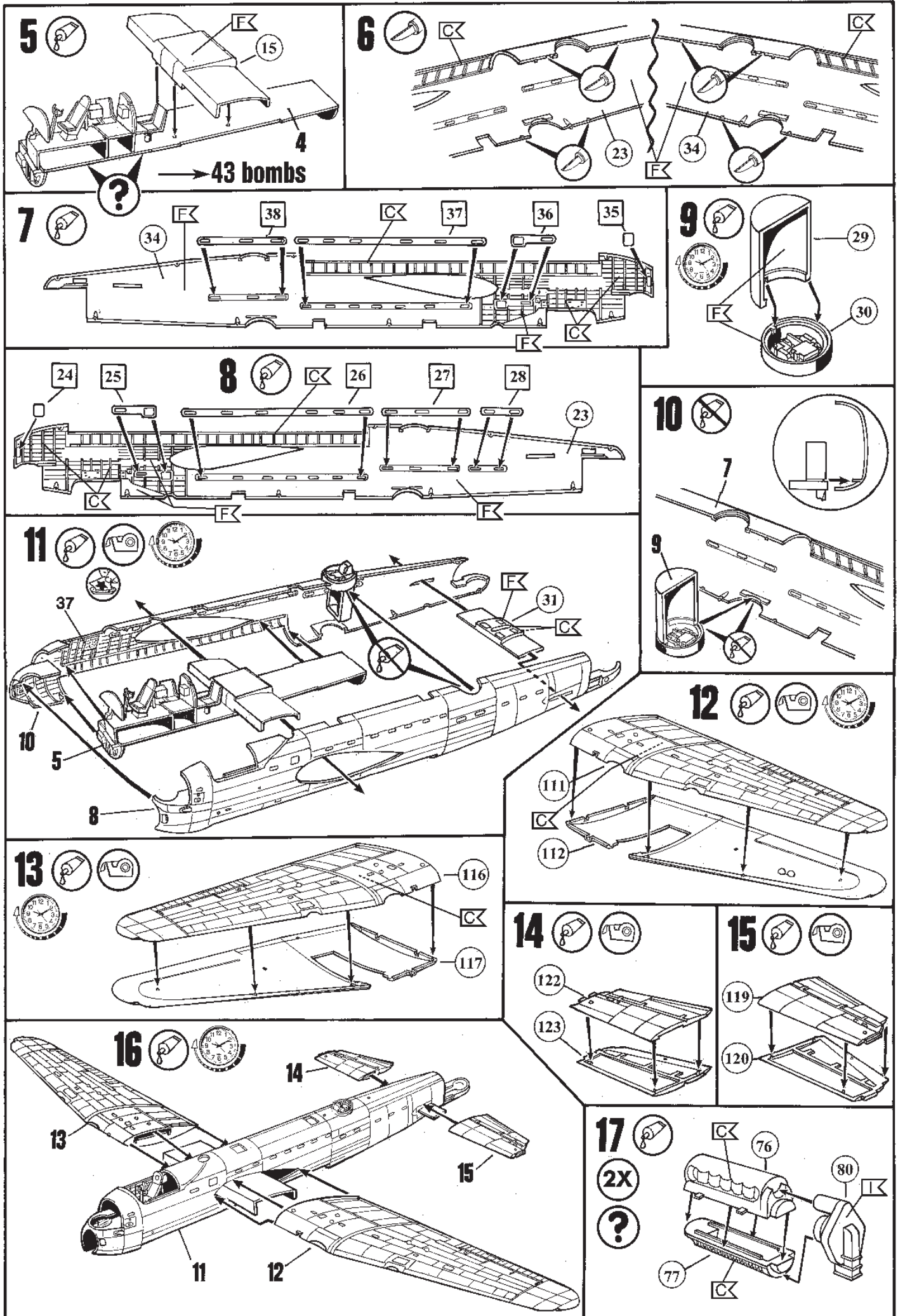

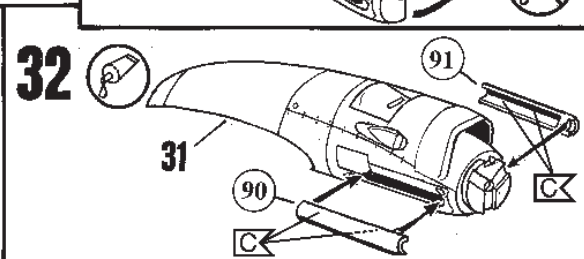
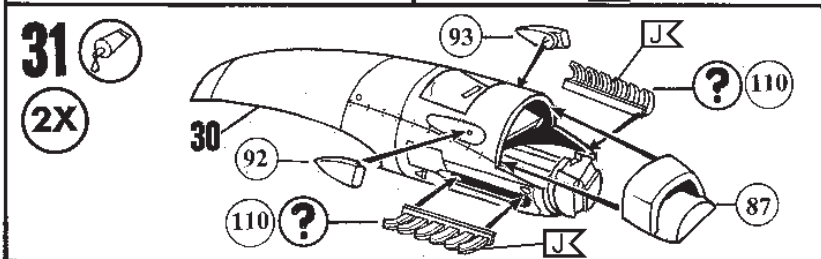
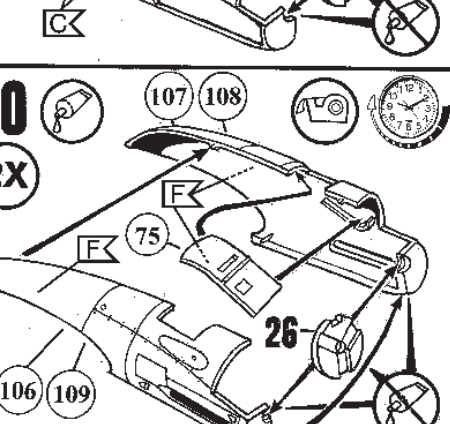
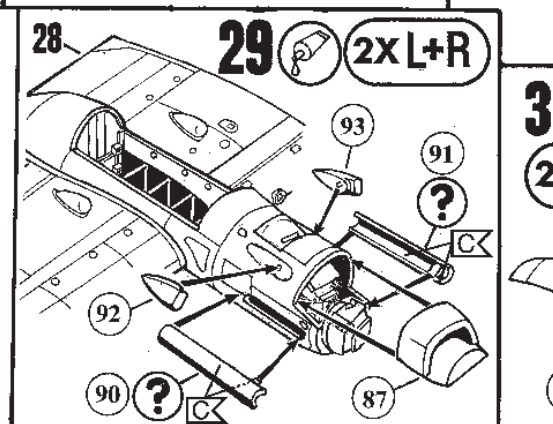
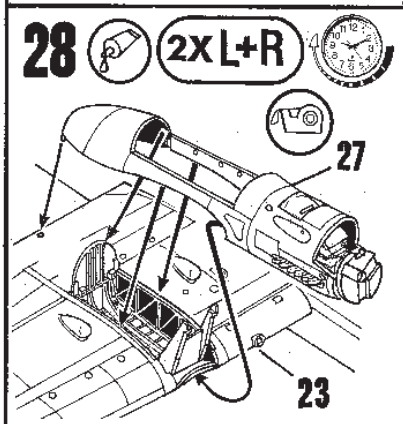
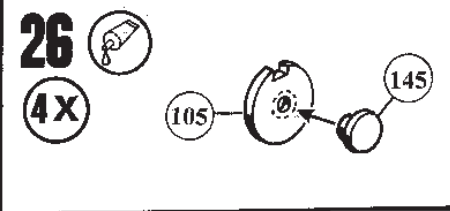
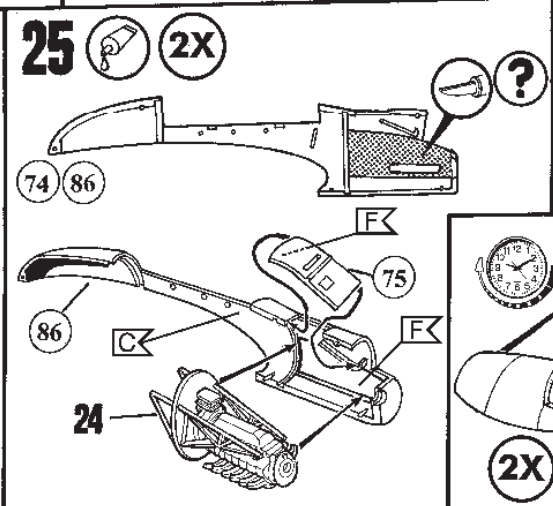
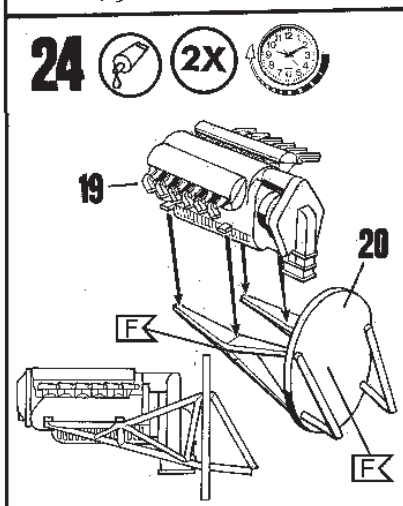
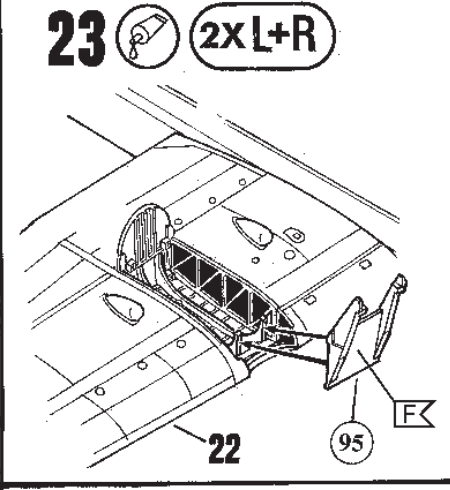
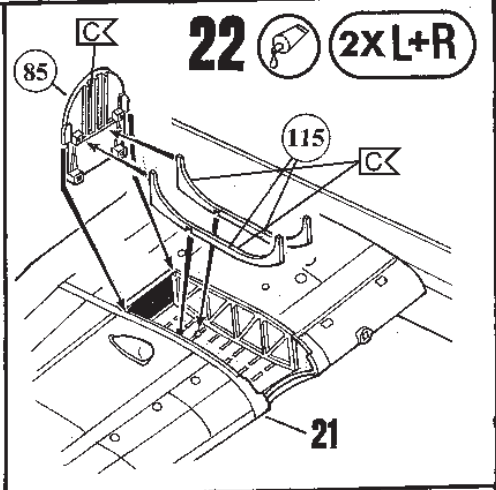
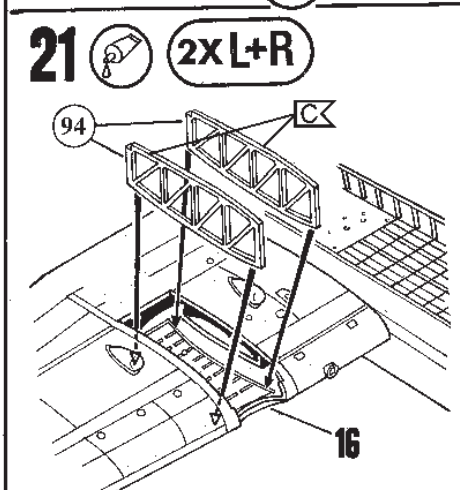
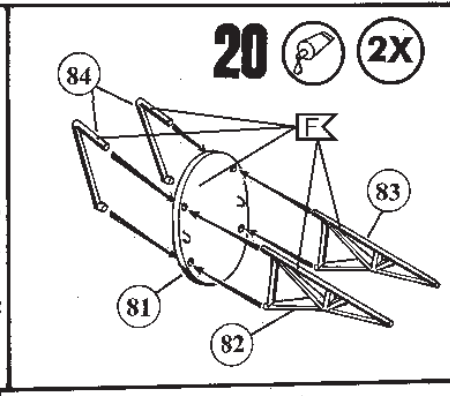
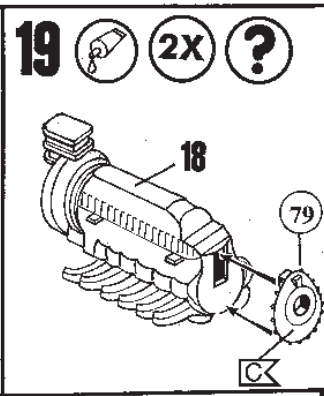
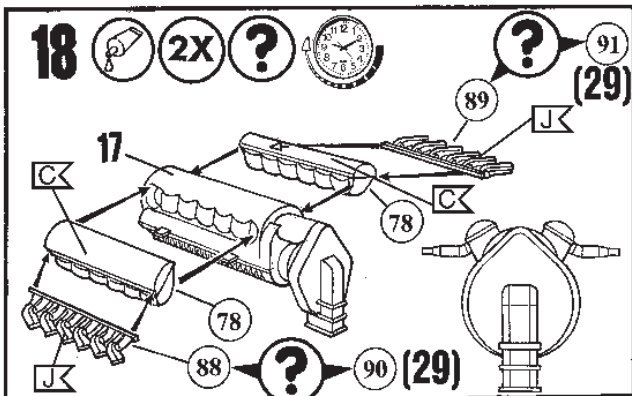

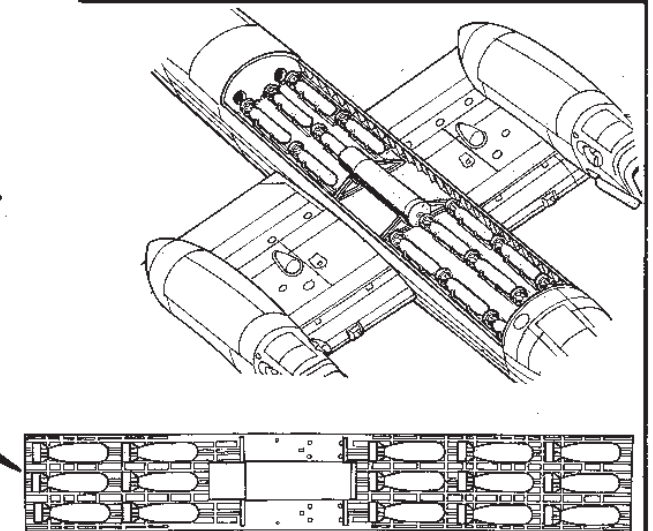
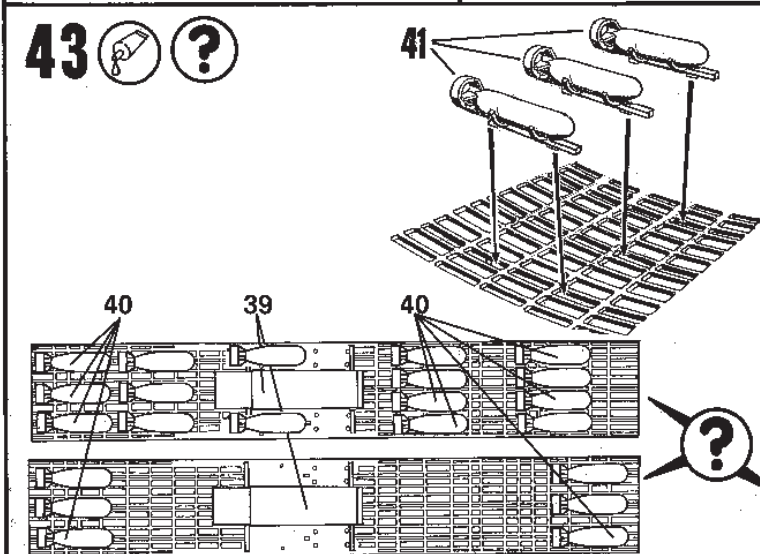
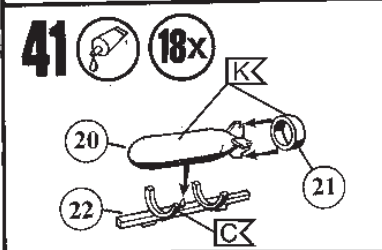
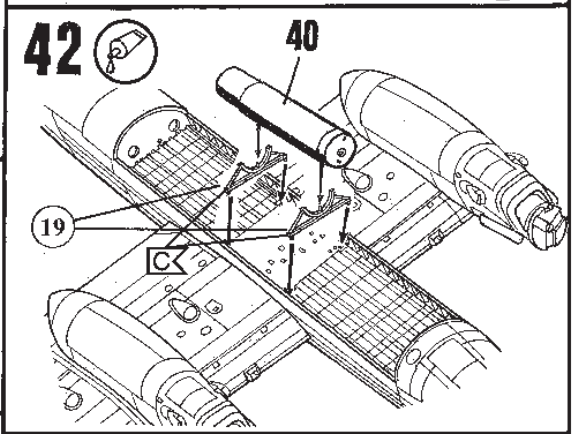
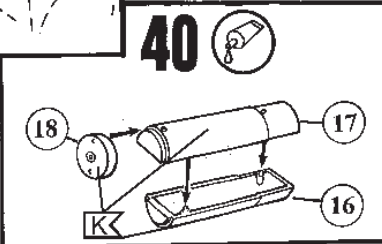
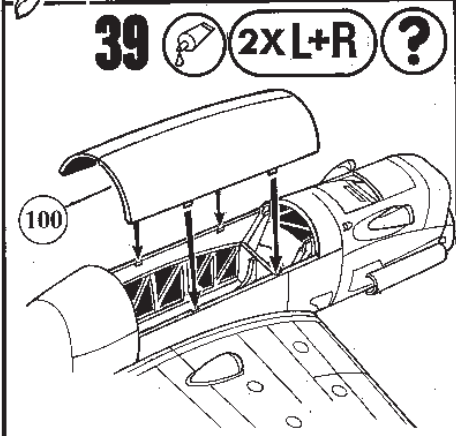
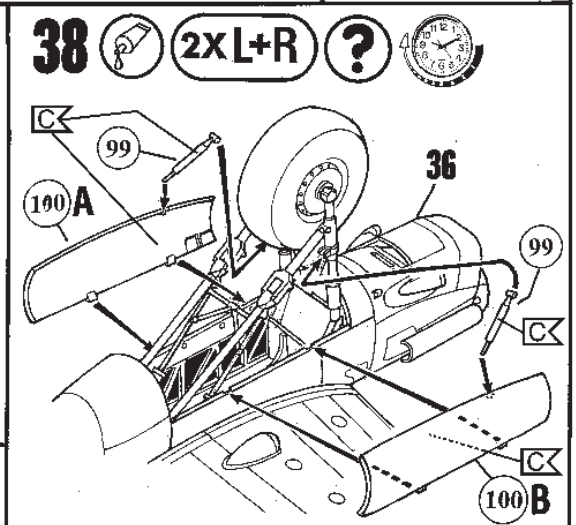
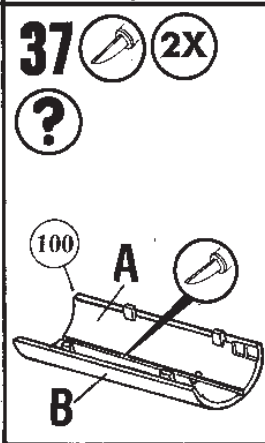
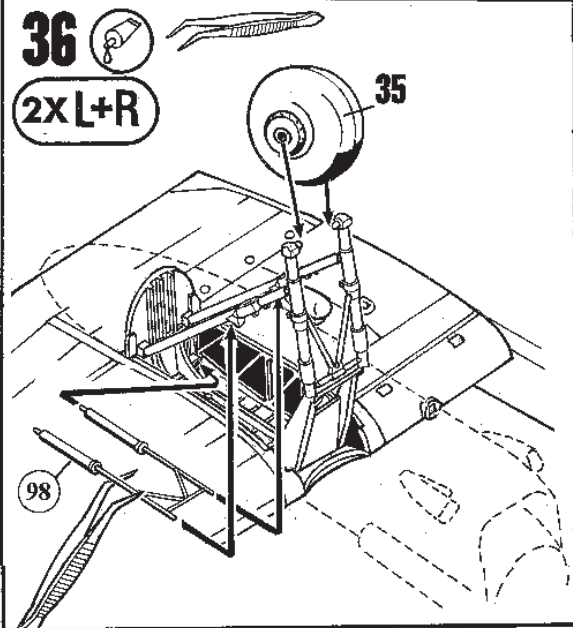
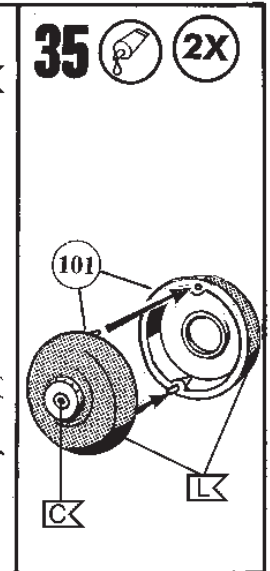
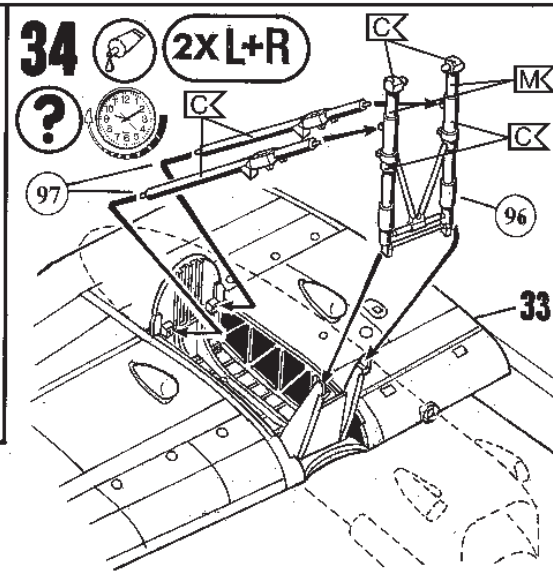
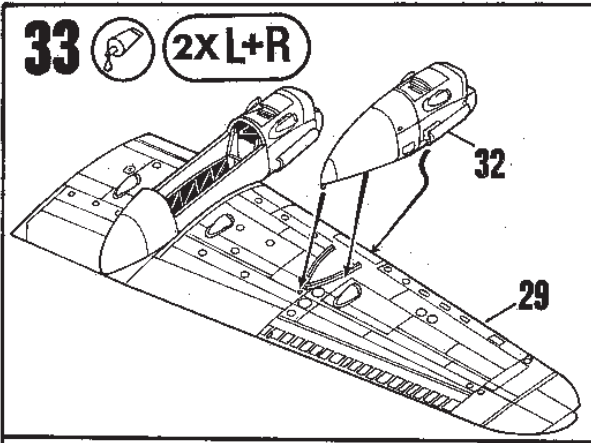

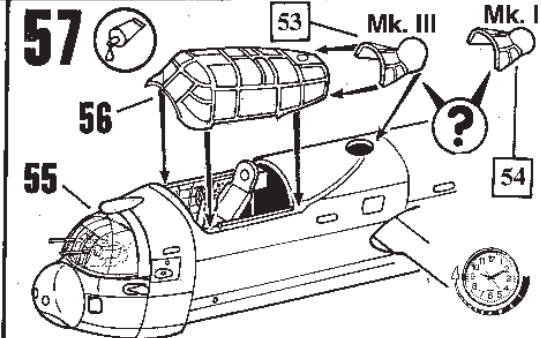
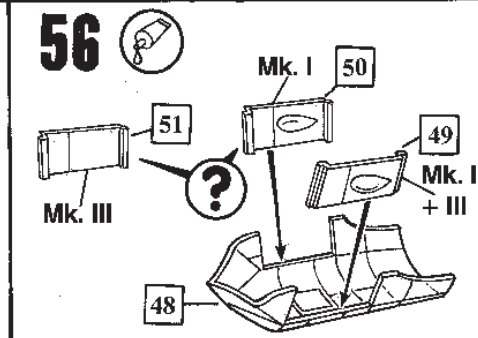
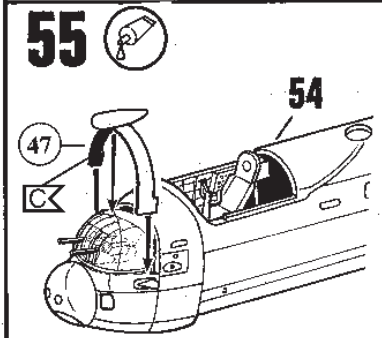
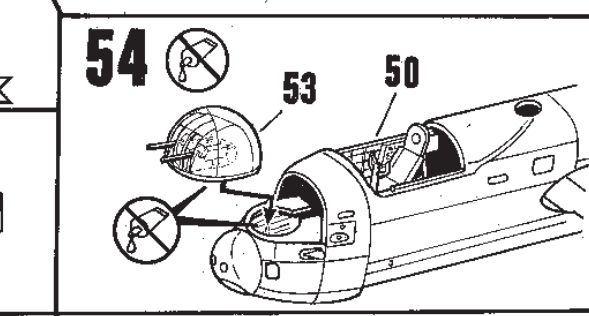
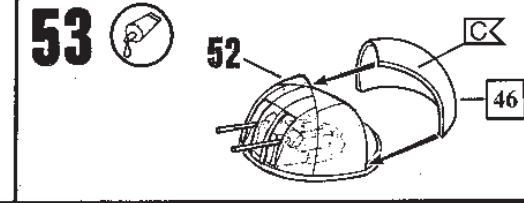
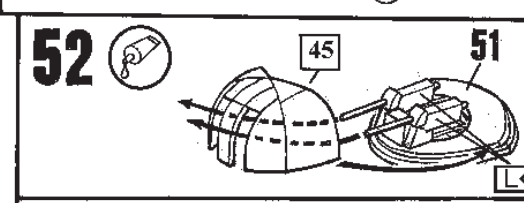
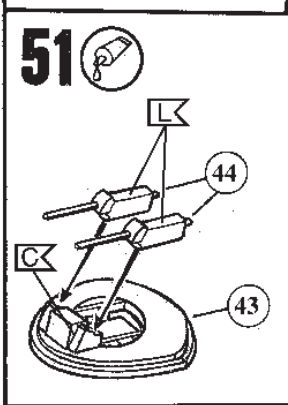
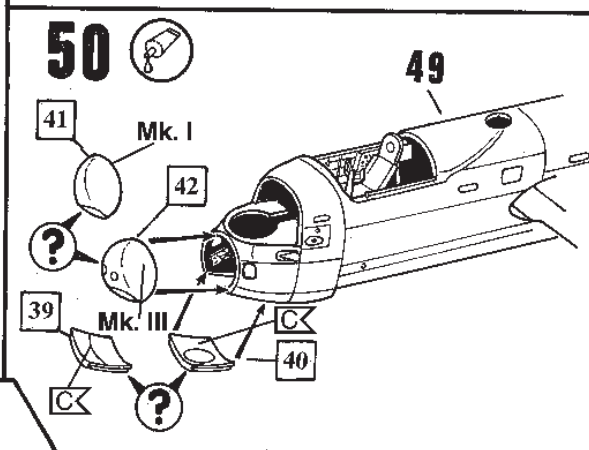
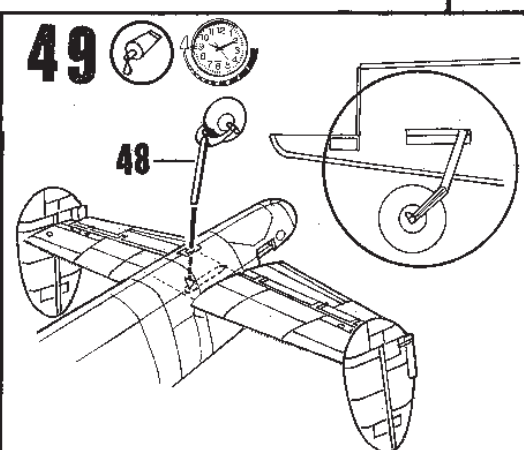
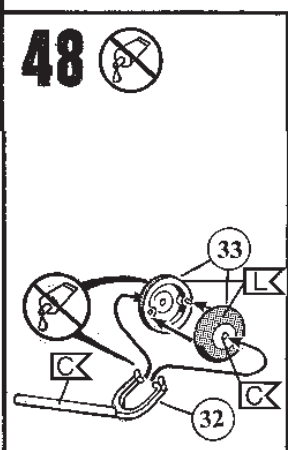
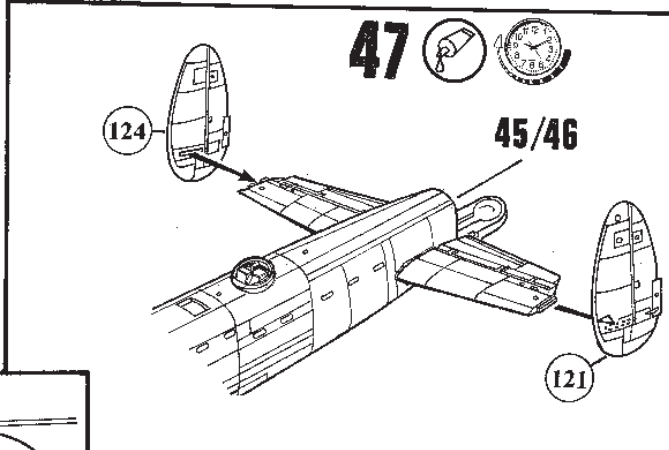
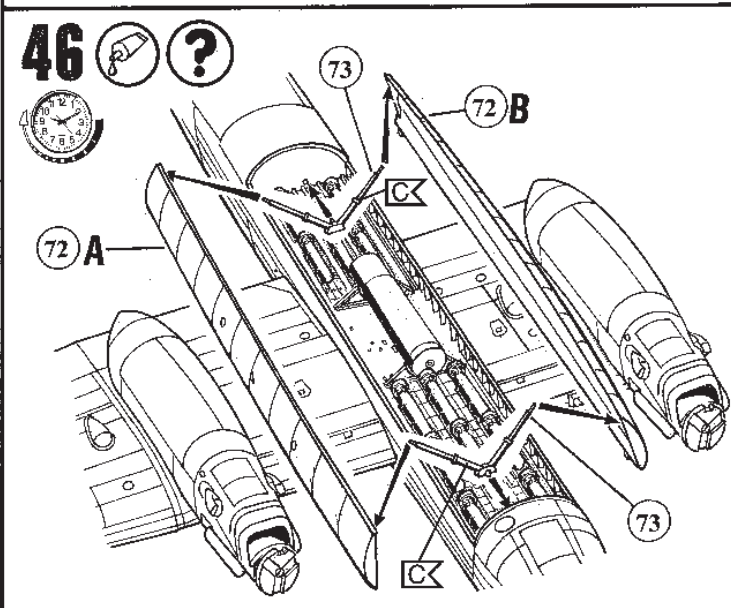
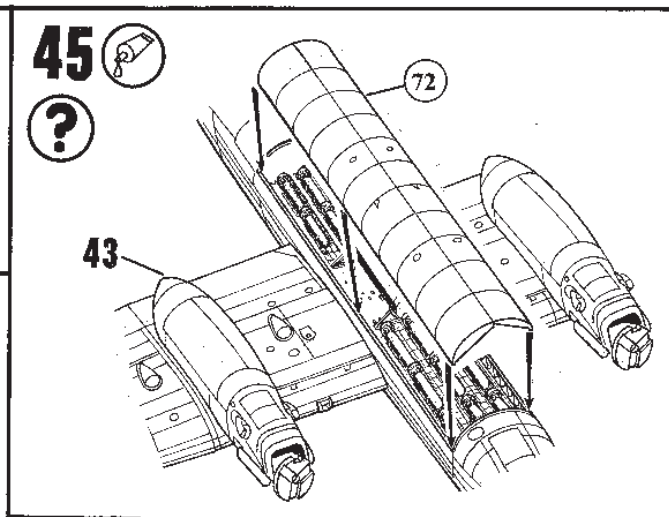
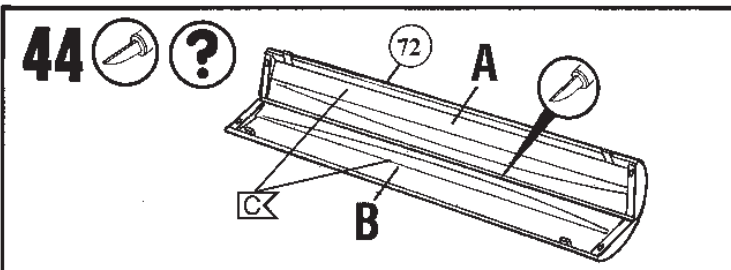

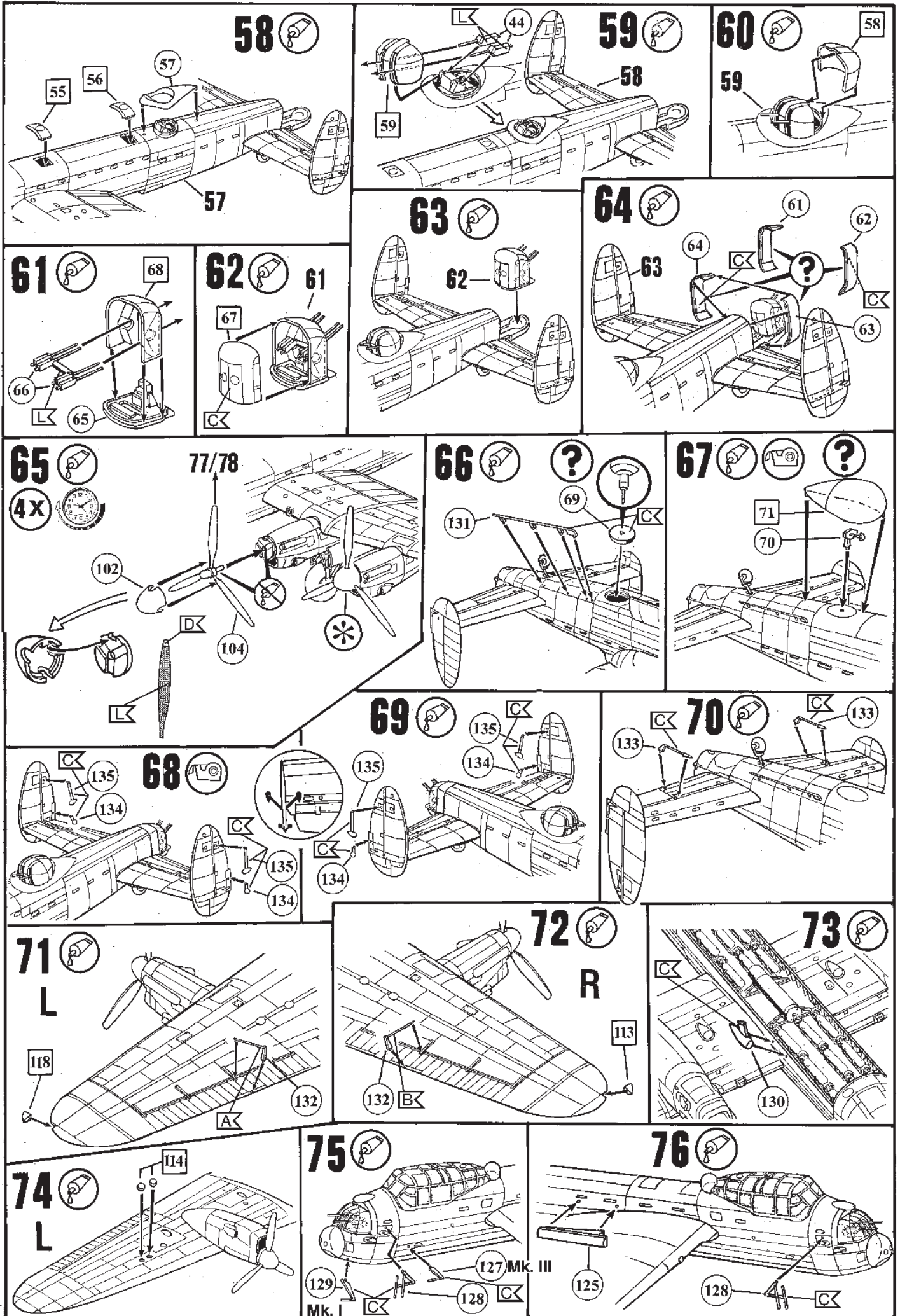

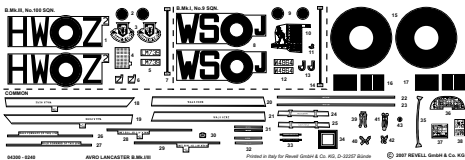

Avro Lancaster B.Mk.III, No. 100 Squadron, Royal Air Force, Elsham Wolds, April 1945.

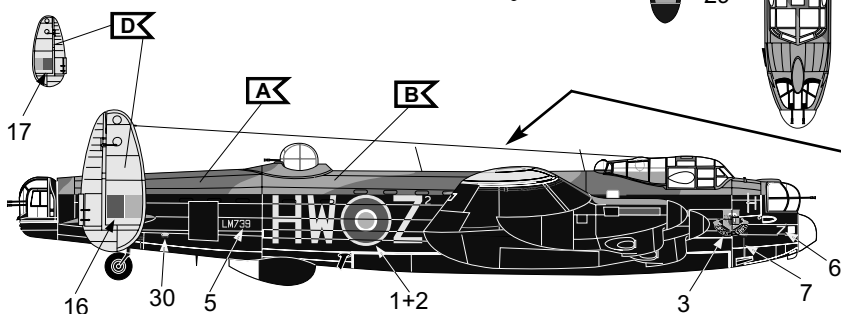
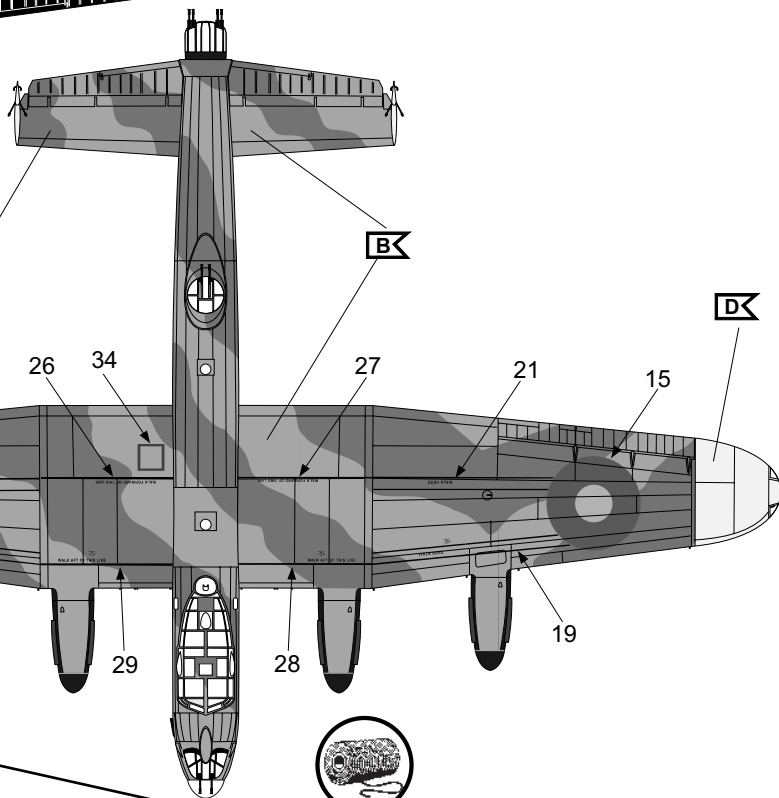
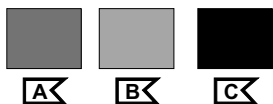
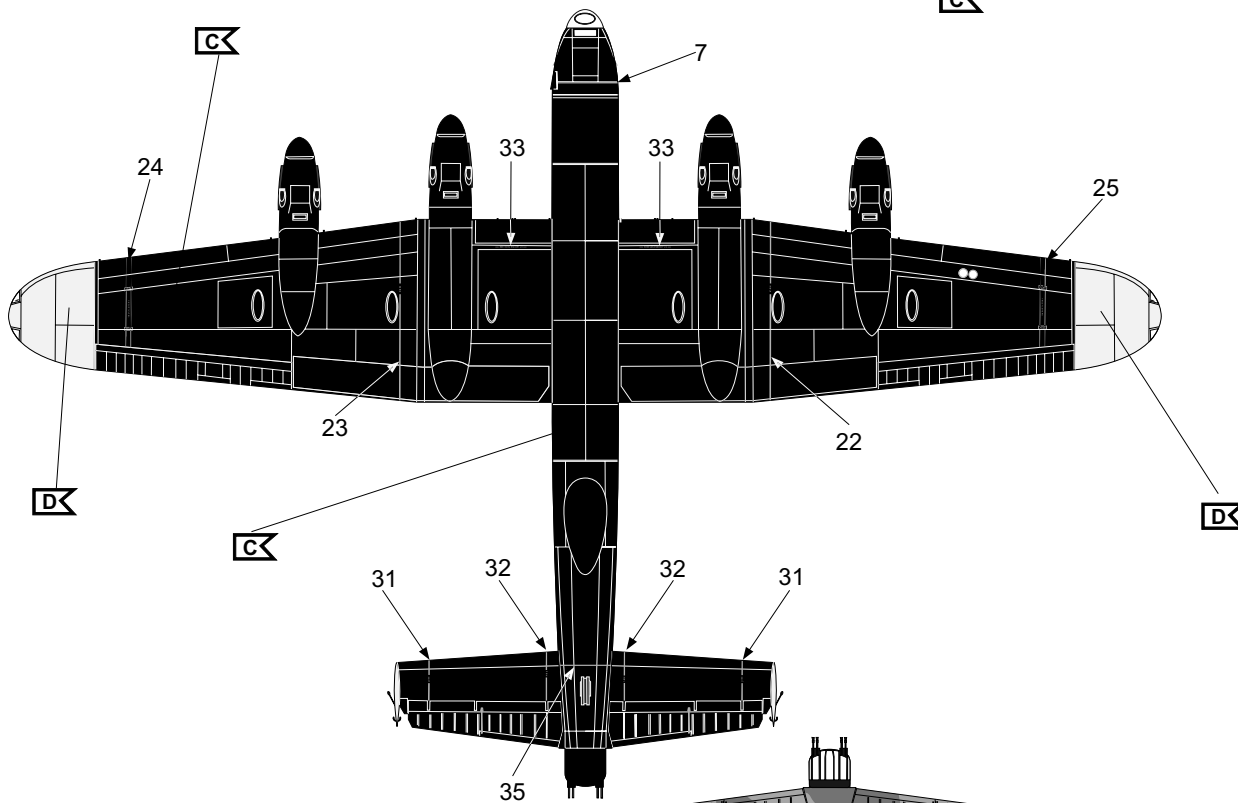
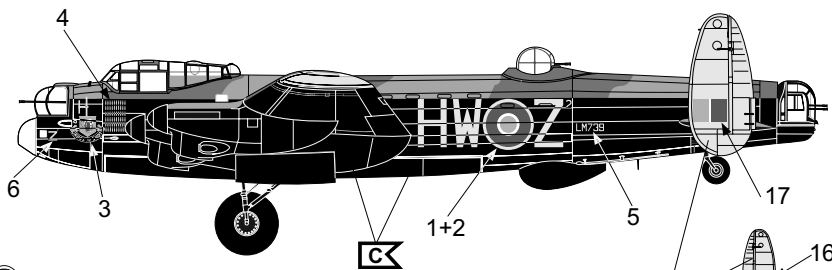

Schwarzen Faden benutzen
Use black thread
Employer le fil noir
Gebruik zwarte draad
Utilizar hilo color negro
Utilizar filo preto
Använd svarta trådar
Käytä mustaa lankaa

Benyt en sort
Bruk svart
Использовать черные нитки
Użyć czarnej nici
χρησιμοποιείστε την καφέ μαύρου
Kahverengi siyah iplik kullanın
Použit černé vlákno
barna feketé fonalat kell használni
Uporabljati črni nit

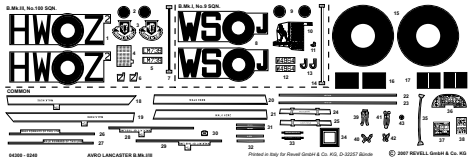

Avro Lancaster B.Mk.I, No. 9 Squadron, Royal Air Force, Bardney, 1945.

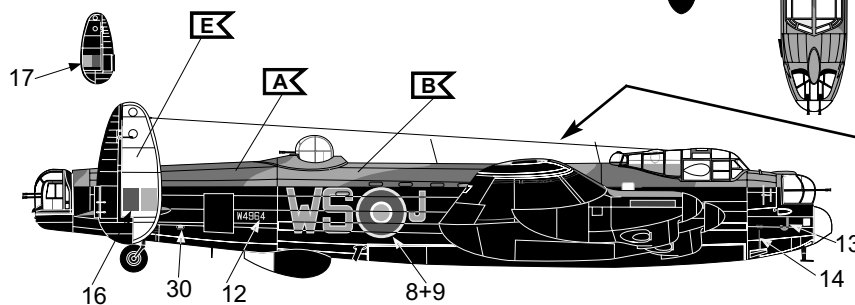
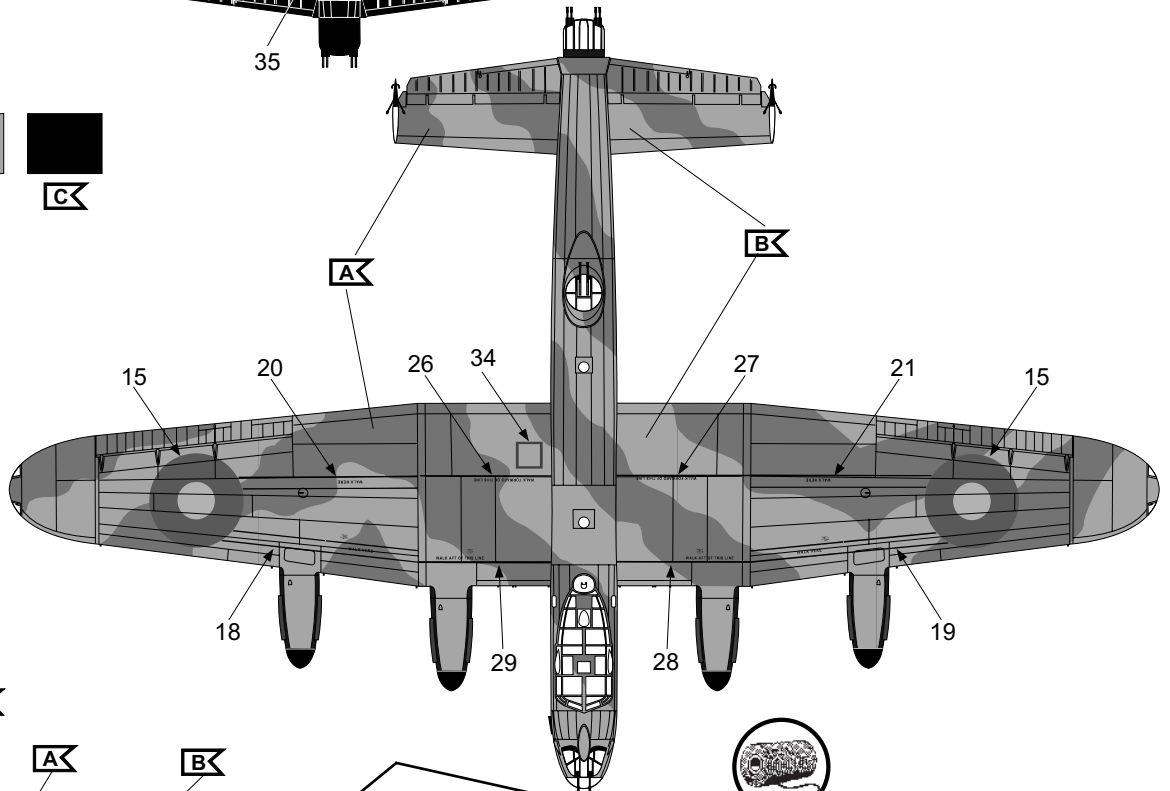
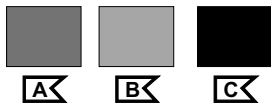
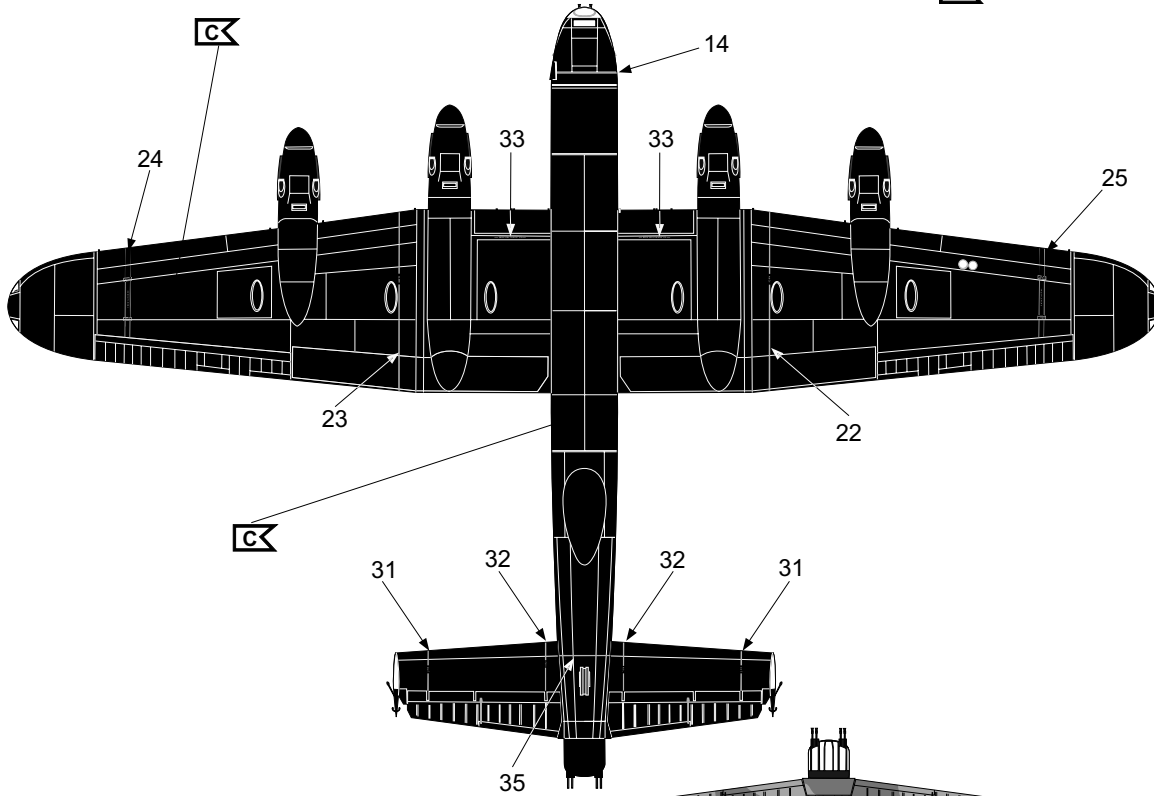
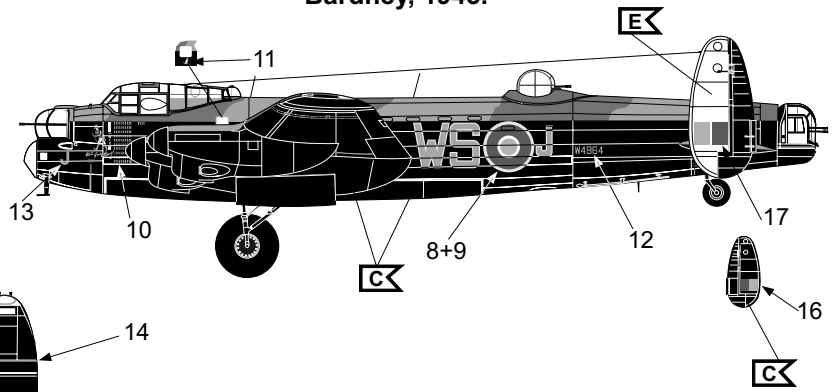
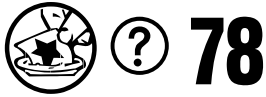

Schwarzen Faden benutzen
Use black thread
Employer le fil noir
Gebruik zwarte draad
Utilizar hilo color negro
Utilizar fio preto
Usare filo nero
Använd svart trådar
Käytä mustaa lankaa

Benyt en sort
Bruk svart
Использовать черные нитки
Użyć czarnej nici
Χρησιμοποιήστε την καφέ μαύρου
Kahverengi siyah iplik kullanın
Použit černé vlákno
barna feketete fonalat kell használni
Uporabljati črni nit