

600 Scale Fuselage 500E **INSTRUCTION MANUAL** **使用說明書**



Model:KZ0910102A



Model:KZ0910103A

Thank you for buying ALIGN products. Please read this manual carefully before assembling. We recommend that you keep this manual for future reference regarding tuning and maintenance.

承蒙閣下選用亞拓遙控世界系列產品，謹表謝意。進入遙控世界之前必須告訴您許多相關的知識與注意事項，以確保您能夠在學習的過程中較得心應手。在開始操作之前，請務必詳閱本說明書，相信一定能夠給您帶來相當大的幫助，也請您妥善保管這本說明書，以作為日後參考。

Contents

1	INTRODUCTION 前言
1~2	SAFETY NOTES 安全注意事項
3	PREPARATION BEFORE ASSEMBLING 組裝前準備事項
4~7	ASSEMBLY STEPS 組裝步驟
8	ASSEMBLY ILLUSTRATION 組裝完成圖

Thank you for buying ALIGN Products. 600 scale fuselage is designed as an easy to use. Please read the manual carefully before assembling the model, and follow all precautions and recommendations located within the manual. Be sure to retain the manual for future reference, routine maintenance, and tuning. The scale fuselage is designed for ALIGN T-REX 600Nitro Helicopter series use. You can easily put it on your T-REX 600Nitro for new clothing.

感謝您選購亞拓產品，為了讓您容易方便的使用 600 像真機殼，請您詳細的閱讀完這本說明書之後再進行組裝以及操作這台直昇機，同時請您妥善的保存這本說明書、作為日後進行調整以及維修的參考。本像真機殼為針對亞拓 T-REX 600Nitro 系列直昇機之規格所設計，只要您擁有 T-REX 600Nitro，就可輕鬆為牠換件新衣，讓您成為眾所注目的焦點。

THE MEANING OF SYMBOLS 標誌代表涵義

 WARNING 警告	Mishandling due to failure to follow these instructions may result in damage or injury. 因為疏忽這些操作說明，而使用錯誤可能造成財產損失或嚴重傷害。
 CAUTION 注意	Mishandling due to failure to follow these instructions may result in danger. 因為疏忽這些操作說明，而使用錯誤可能造成危險。
 FORBIDDEN 禁止	Do not attempt under any circumstances. 在任何禁止的環境下，請勿嘗試操作。

IMPORTANT NOTES 重要聲明

R/C helicopters are not toys. R/C helicopter utilize various high-tech products and technologies to provide superior performance. Improper use of this product can result in serious injury or even death. Please read this manual carefully before using and make sure to be conscious of your own personal safety and the safety of others and your environment when operating all ALIGN products.

Manufacturer and seller assume no liability for the operation or the use of this product.

Intended for use only by adults with experience flying remote control helicopters at a legal flying field. After the sale of this product we cannot maintain any control over its operation or usage.

After assembling the scale fuselage, the weight will increase and the structure will be more complex, so we recommend not flying 3D to avoid any accident and damage.

遙控直昇機並非玩具，它是結合了許多高科技產品所設計出來的休閒用品，所以商品的使用不當或不熟悉都可能造成嚴重傷害甚至死亡，使用之前請務必詳讀本說明書，勿輕忽並注意自身安全。注意！任何遙控直昇機的使用，製造商和經銷商是無法對使用者於零件使用的損耗異常或組裝不當所發生之意外負任何責任，本產品是提供給有操作過模型直昇機經驗的成人或有相當技術的人員在旁指導於當地合法遙控飛行場飛行，以確保安全無虞下操作使用，產品售出後本公司將不負任何操作和使用控制上的任何性能與安全責任。安裝像真機殼後由於重量加重，且增加了結構的複雜性，故不建議進行3D飛行，以免發生不可預期的意外及損失。

R/C products require a certain degree of skill to operate, and is a consumer item. Any damage or dissatisfaction as a result of accidents or modifications are not covered by any warrantee and cannot be returned for repair or replacement. Please contact our distributors for free technical consultation and parts at discounted rates when you experience problems during operation or maintenance.

模型商品屬於需高操作技術且為消耗性之商品，如經拆裝使用後，會造成不等情況零件損耗，任何使用情況所造成商品不良或不滿意，將無法於保固條件內更換新品或退貨，如遇有使用操作維修問題，本公司全省分公司或代理商將提供技術指導、特價零件供應服務。

2. SAFETY NOTES 安全注意事項



Fly only in safe areas, away from other people. Do not operate R/C aircraft within the vicinity of homes or crowds of people. R/C aircraft are prone to accidents, failures, and crashes due to a variety of reasons including, lack of maintenance, pilot error, and radio interference. Pilots are responsible for their actions and damage or injury occurring during the operation or as of a result of R/C aircraft models.

遙控模型飛機、直昇機屬高危險性商品，飛行時務必遠離人群，人為組裝不當或機件損壞、電子控制設備不良，以及操控上的不熟悉、都有可能導致飛行失控損傷等不可預期的意外，請飛行者務必注意飛行安全，並需了解自負疏忽所造成任何意外之責任。



LOCATE AN APPROPRIATE LOCATION 遠離障礙物及人群

R/C helicopters fly at high speed, thus posing a certain degree of potential danger. Choose an a legal flying field consisting of flat, smooth ground without obstacles. Do not fly near buildings, high voltage cables, or trees to ensure the safety of yourself, others and your model. For the first practice, please choose a legal flying field and can use a training skid to fly for reducing the damage. Do not fly your model in inclement weather, such as rain, wind, snow or darkness.

直昇機飛行時具有一定的速度，相對的也潛在著危險性，場地的選擇也相對的重要，請需遵守當地法規到合法遙控飛行場地飛行。必須注意周遭有沒有人、高樓、建築物、高壓電線、樹木等等，避免操控的不當造成自己與他人財產的損壞。初次練習時，務必選擇在空曠合法專屬飛行場地並適當搭配練習架練習飛行，這對飛行失誤所造成的損傷將會大幅的降低。請勿在下雨、打雷等惡劣天候下操作，以確保本身及機體的安全。



PREVENT MOISTURE 遠離潮濕環境

R/C models are composed of many precision electrical components. It is critical to keep the model and associated equipment away from moisture and other contaminants. The introduction or exposure to water or moisture in any form can cause the model to malfunction resulting in loss of use, or a crash. Do not operate or expose to rain or moisture.

直昇機內部也是由許多精密的電子零組件組成，所以必須絕對的防止潮濕或水氣，避免在浴室或雨天時使用，防止水氣進入機身內部而導致機件及電子零件故障而引發不可預期的意外！



PROPER OPERATION 勿不當使用本產品

Please use the replacement of parts on the manual to ensure the safety of instructors. This product is for R/C model, so do not use for other purpose.

請勿自行改造加工，任何的升級改裝或維修，請使用亞拓產品目錄中的零件，以確保結構的安全。請確認於產品限界內操作，請勿過載使用，並勿用於安全、法令外其它非法用途。



OBTAIN THE ASSISTANCE OF AN EXPERIENCED PILOT 避免獨自操控

Before turning on your model and transmitter, check to make sure no one else is operating on the same frequency. Frequency interference can cause your model, or other models to crash. The guidance provided by an experienced pilot will be invaluable for the assembly, tuning, trimming, and actual first flight. (Recommend you to practice with computer-based flight simulator.)

至飛行場飛行前，需確認是否有相同頻率的同好正進行飛行，因為開啓相同頻率的發射機將導致自己與他人立即干擾等意外危險。遙控飛機操控技巧在學習初期有著一定的難度，要盡量避免獨自操作飛行，需有經驗的人士在旁指導，才可以操控飛行。(勤練電腦模擬器及老手指導是入門必要的選擇)



SAFE OPERATION 安全操作

Operate this unit within your ability. Do not fly under tired condition and improper operation may cause in danger.

請於自己能力內及需要一定技術範圍內操作這台直昇機，過於疲勞、精神不佳或不當操作，意外發生風險將可能會提高。



ALWAYS BE AWARE OF THE ROTATING BLADES 遠離運轉中零件

During the operation of the helicopter, the main rotor and tail rotor will be spinning at a high rate of speed. The blades are capable of inflicting serious bodily injury and damage to the environment. Be conscious of your actions, and careful to keep your face, eyes, hands, and loose clothing away from the blades. Always fly the model a safe distance from yourself and others, as well as surrounding objects. Never take your eyes off the model or leave it unattended while it is turned on. Immediately turn off the model and transmitter when you have landed the model.

當直昇機主旋翼與尾旋翼運轉時，切勿觸摸並遠離任何物件，以避免造成危險及損壞。



KEEP AWAY FROM HEAT 遠離熱源

R/C models are made up various forms of plastic. Plastic is very susceptible to damage or deformation due to extreme heat and cold climate. Make sure not to store the model near any source of heat such as an oven, or heater. It is best to store the model indoors, in a climate-controlled, room temperature environment.

遙控飛機多半是以 PA 纖維或聚乙烯、電子商品為主要材質，因此要盡量遠離熱源、日曬，以避免因高溫而變形甚至熔毀損壞的可能。



600 scale fuselage, suitable for T-REX 600 Nitro Helicopter series.

600像真機殼，適用於T-REX 600Nitro遙控直昇機系列。

BEFORE ASSEMBLING 組裝前準備事項

1. Check for all the parts in the list come with the manual.

2. Some basic tools are needed to help the assembly.

1. 組裝之前請先確定內容物是否有缺失，仔細詳對後方可進行組裝。
2. 組裝過程裡需要一些簡單的工具協助組裝。

TOOL 自備工具

1. Cutter knife 2. Hexagon screw driver 3. Phillips screw driver 4. File
5. Diagonal cutting pliers 6. Fine sandpaper 7. CA glue 8. AB glue
9. Silicone 10. Scissors

1. 美工刀 2. 六角起子 3. 十字起子 4. 銼刀 5. 斜口鉗 6. 細砂紙 7. 瞬間膠 8. AB膠
9. 透明矽膠 10. 剪刀

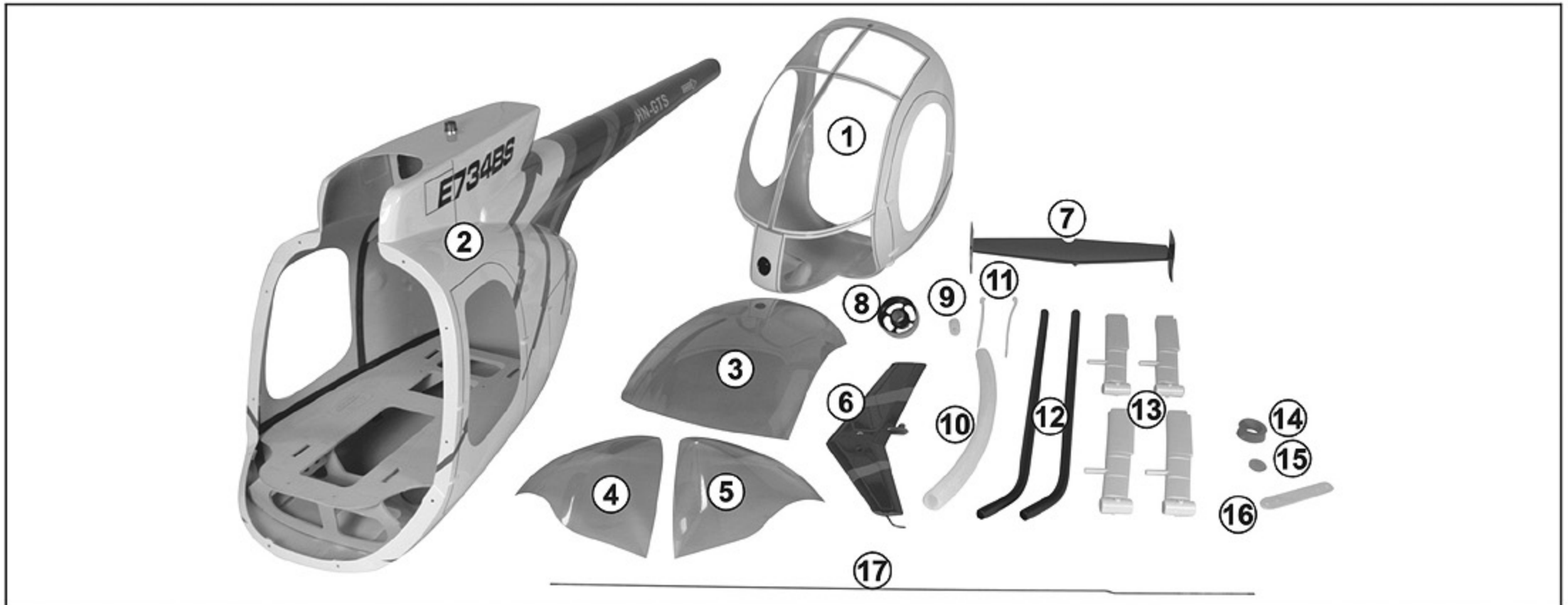

1. 500E Canopy

2. Fuselage

3. 500E Canopy cover (Front)

4. 500E Canopy cover (Right lower)

5. 500E Canopy cover (Left lower)

6. Vertical stabilizer

7. Horizontal stabilizer

8. Exhaust mount

9. Joint tube

10. Exhaust tube

11. Nylon strap

12. Skid pipe

13. Landing skid

14. Tail boom guide

15. Pellucid plastic lens

16. Fixing plate

17. Rudder control rod C

1. 500E機頭罩x1

2. 500E機殼x1

3. 500E機艙罩(前)x1

4. 500E機艙罩(右下)x1

5. 500E機艙罩(左下)x1

6. 垂直翼x1

7. 水平翼x1

8. 排煙管座x1

9. 轉接管x1

10. 排煙導管x1

11. 束帶x2

12. 腳架鋁管x2

13. 腳架x4

14. 尾管固定環x1

15. 透明塑膠鏡片x1

16. 底板固定片x1

17. 尾舵控制連桿Cx1

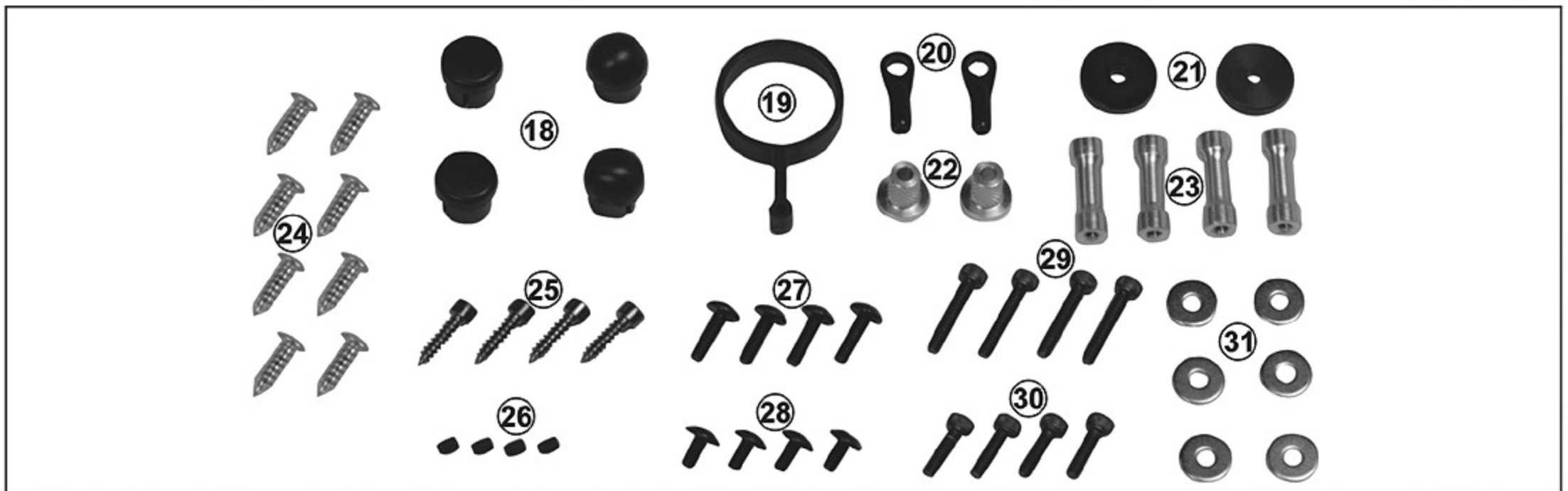

18. Skid pipe end cap

19. Tail control guide

20. Ball link

21. Plastic spacer

22. Aluminum insert

23. ELEV servo pole

24. Round head tapping screw

25. Socket head screw

26. Set screw

27. Socket button head screw

28. Socket button head screw

29. Socket head screw

30. Socket head screw

31. Washer

18. 腳架鋁管保護套x4

19. 尾控制桿固定環x1

20. 連桿頭x2

21. 塑膠墊片x2

22. 垂直翼固定鋁套x2

23. ELEV伺服器固定柱20mmx4

24. 圓頭十字自攻螺絲T3x10mmx8

25. 圓頭內六角螺絲T3x12mmx4

26. 止洩螺絲M3x4mmx4

27. 半圓頭內六角螺絲M3x10mmx4

28. 半圓頭內六角螺絲M3x6mmx4

29. 圓頭內六角螺絲M3x16mmx4

30. 圓頭內六角螺絲M3x10mmx4

31. 華司φ3.4xφ9.9x0.9mmx6

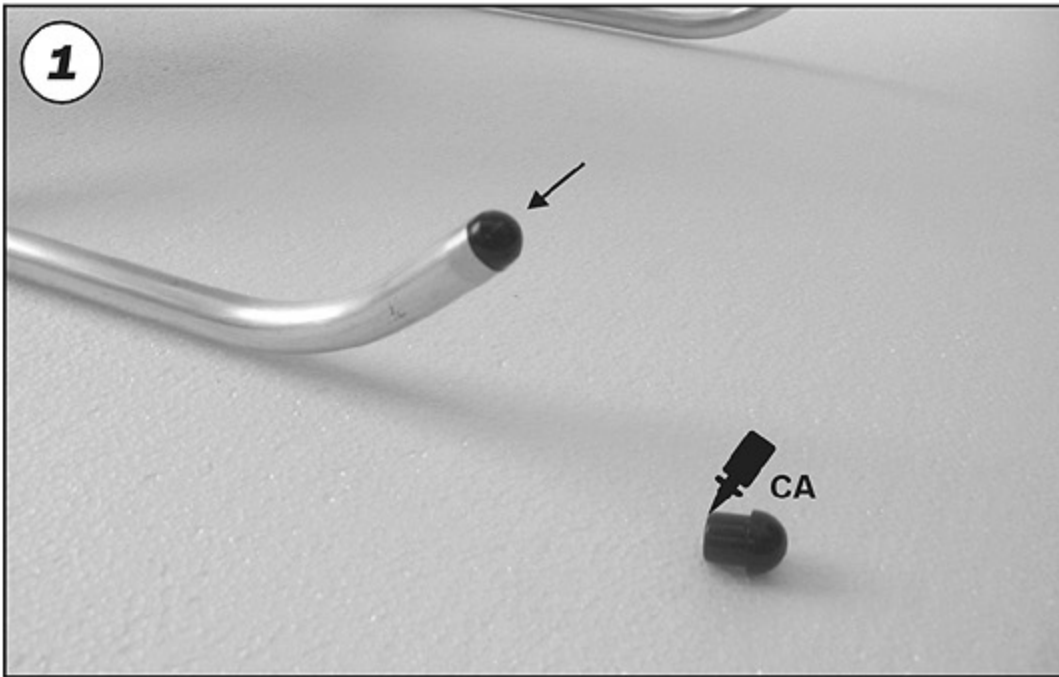

1 Assemble the skid pipe end caps (front) in the skid pipes and apply some CA glue to fix if necessary.

將腳架鋁管保護套(前)壓入腳架鋁管，視需要可以點上少許CA膠予以固定。

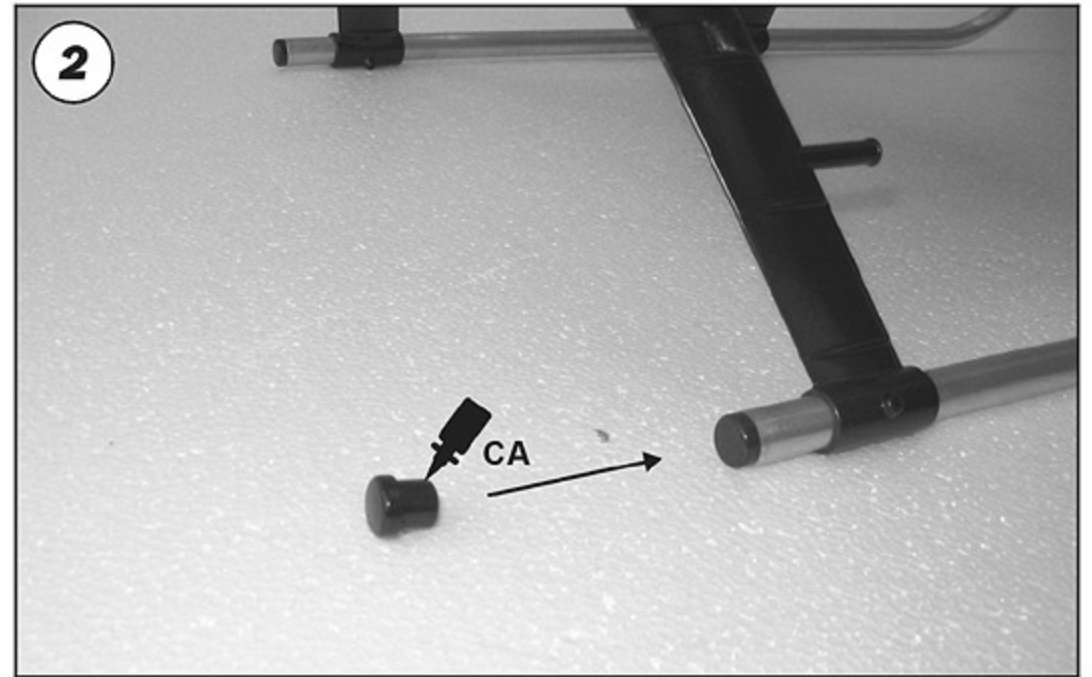

2 Insert the skid pipes through the landing skids. After that, assemble the skid pipe end caps (Rear) in the skid pipes.

接著將鋁管穿入腳架後，將腳架鋁管保護套(後)固定於鋁管上。

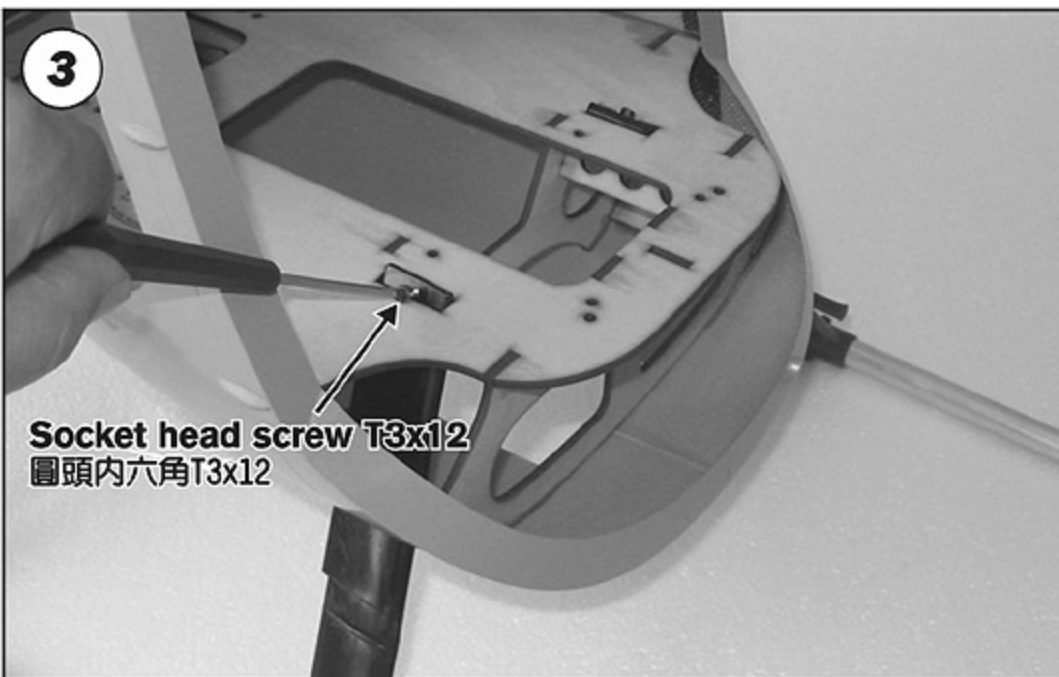

**3 Socket head screw T3x12
圓頭內六角T3x12**

Fasten 4pcs landing skids with socket head screws T3x12.

如上圖標示處，以圓頭內六角螺絲T3x12將4支腳架固定於機身固定架上。

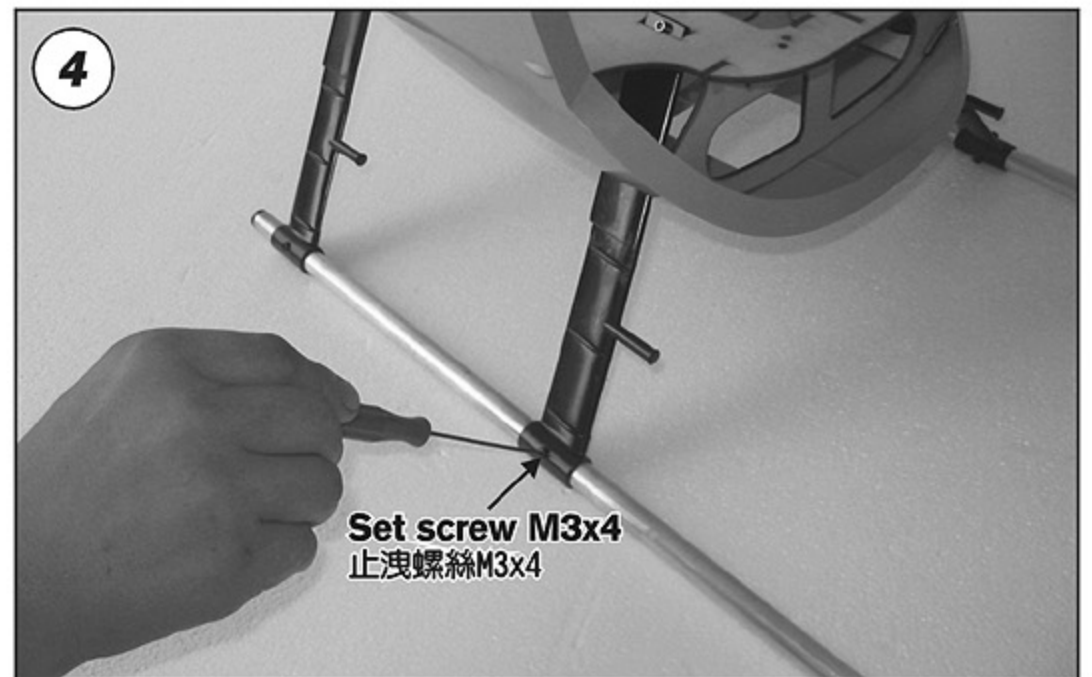

**4 Set screw M3x4
止洩螺絲M3x4**

Fasten the skid pipes with set screws M3x4.

以止洩螺絲M3x4將鋁管固定於腳架上。

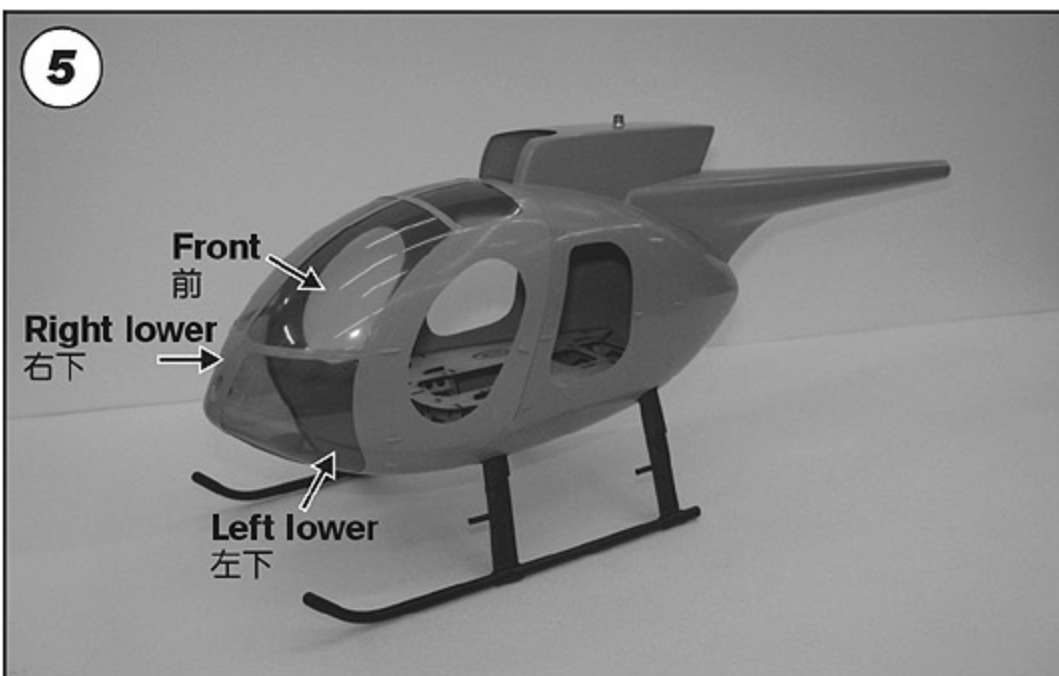

5 Glue the canopy covers inside the canopy with silicone.

將3片機艙罩以透明矽膠固定於機頭罩上。

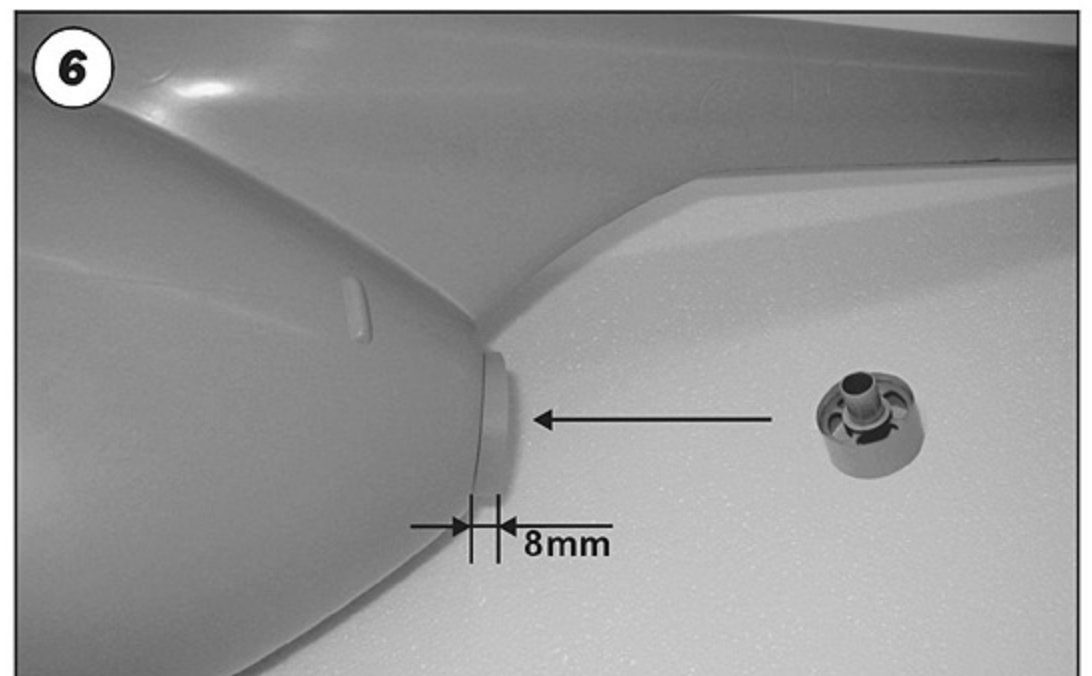

6 Glue the exhaust tube to the fuselage with AB glue or silicone as illustration.

如圖標示位置，將排煙管座以AB或矽膠固定於機身。

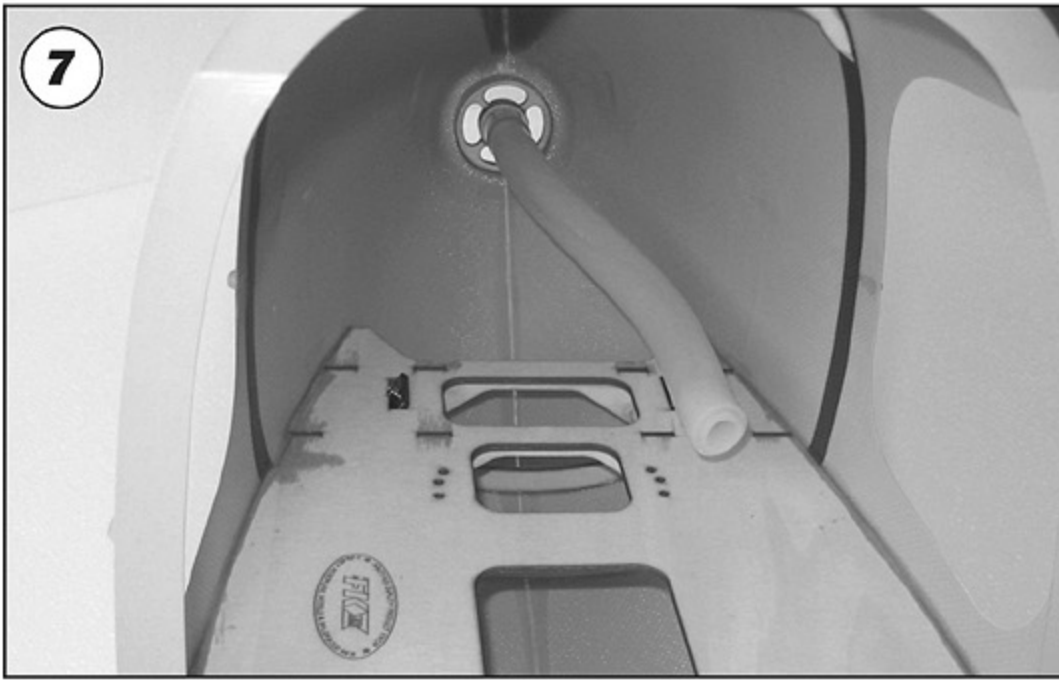

7
Connect the exhaust tube to the exhaust mount and tie them with nylon strap.
 將排煙導管接上排煙管座，並以束帶束緊固定。

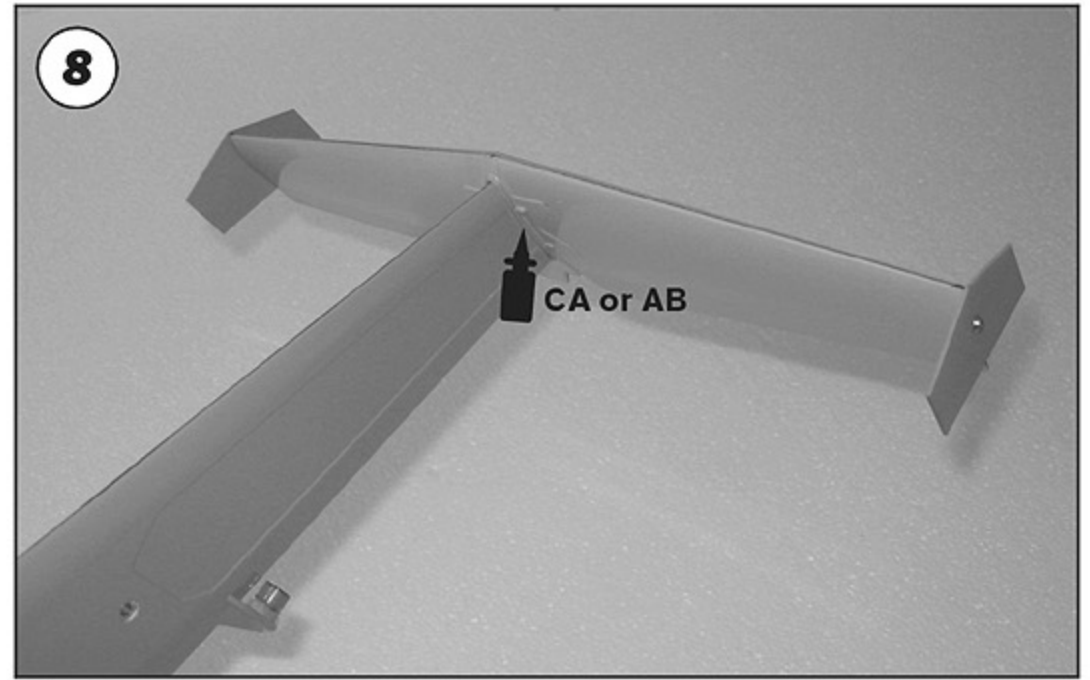

8
Fix the horizontal stabilizer to the vertical stabilizer with CA glue or AB glue.
 以CA或AB膠將水平尾翼固定於垂直翼上。

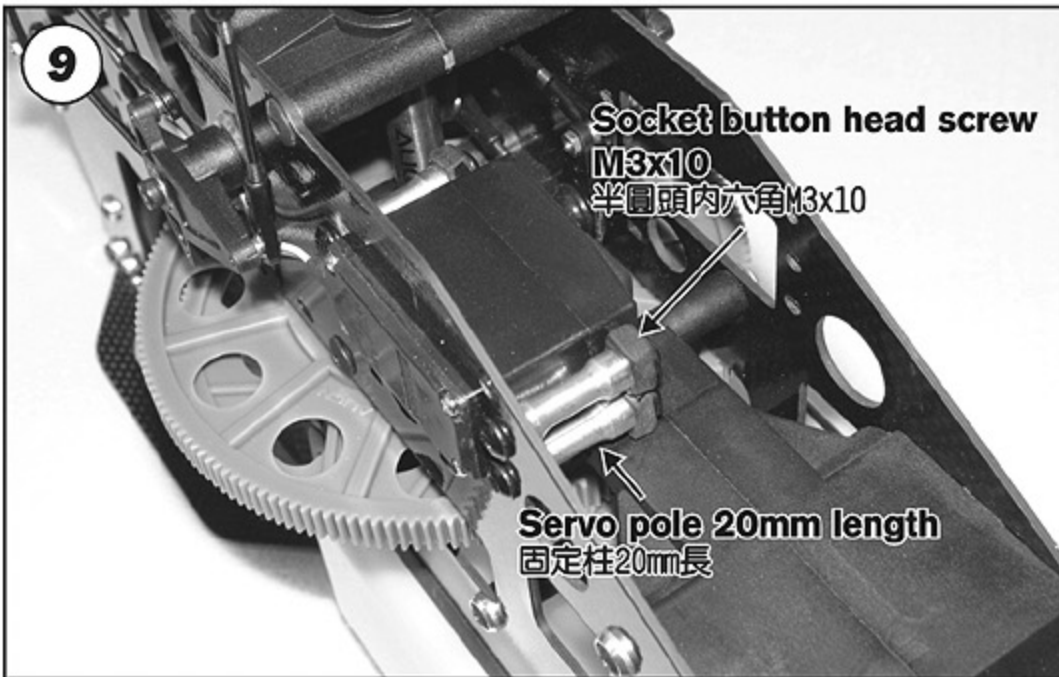

9
Raise the elevator servo by ELEV servo poles and screw it for preventing any interference caused by the fuselage.
 如圖示，將ELEVATOR伺服器以隨附的固定柱(20mm長)架高固定，可避免與機殼干涉。

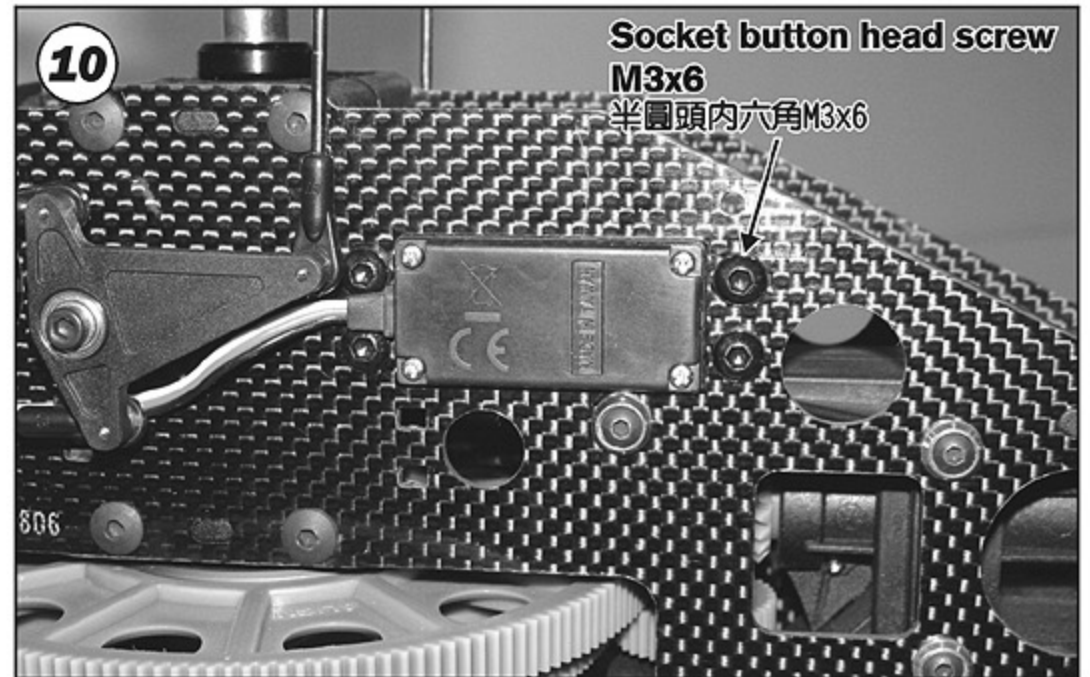

10
Fasten the ELEV servo poles with socket button head screws M3x6.
 以半圓頭內六角螺絲M3x6，將固定柱鎖附於側板。

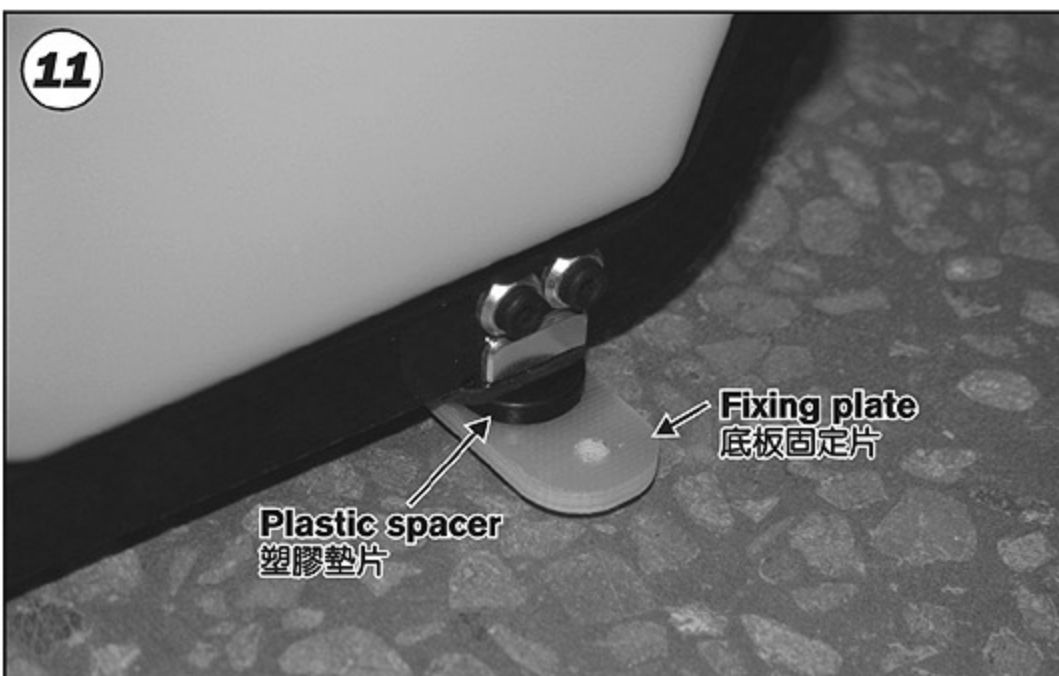

11
First remove the original 600N landing skids. Assemble the plastic spacers and the fixing plate in the back of the bottom plate to raise it.
 先將600N的原腳架拆除，於碳纖底板後方以塑膠墊片和底板固定片將碳纖底板架高。



12
Fasten the spacers and fixing plate to the bottom plate with socket head screws M3x16 and washer $\phi 3.4 \times \phi 9.9 \times \phi 0.9 \text{mm}$.
 以圓頭內六角螺絲M3x16與華司 $\phi 3.4 \times \phi 9.9 \times \phi 0.9 \text{mm}$ 將墊片和固定片鎖附於底板。

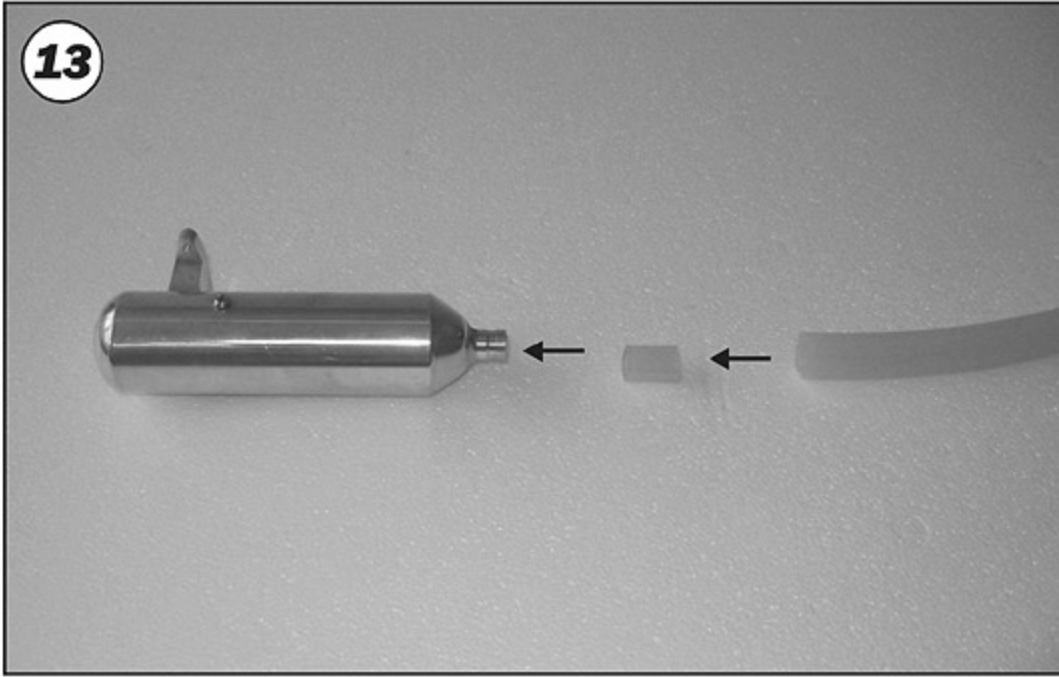

13
Put a smaller silicone joint tube on the muffler and then insert the exhaust tube. Fasten the tube with nylon strap.

將較小的矽膠轉接管先裝入加速管，再將排煙導管推入加速管，並以束帶束緊固定。

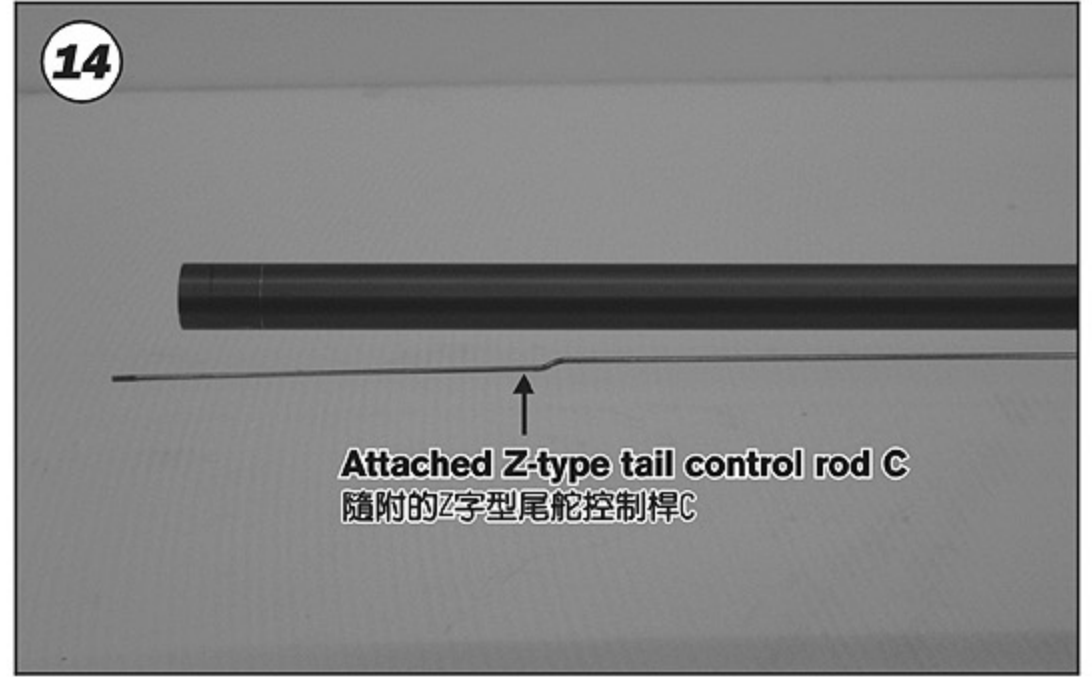

14
Temporarily remove tail case, horizontal and vertical stabilizer, tail control guide, and rudder control rod B. Then assemble the attached Z-type rudder control rod C.

暫先拆下尾齒箱組、平衡翼、垂直翼、尾控制桿固定環與尾舵控制桿B，並裝上隨附的Z字型尾舵控制桿C。



15
Assemble the attached shorter rudder control guide.

裝上隨附較短的尾控制桿固定環。

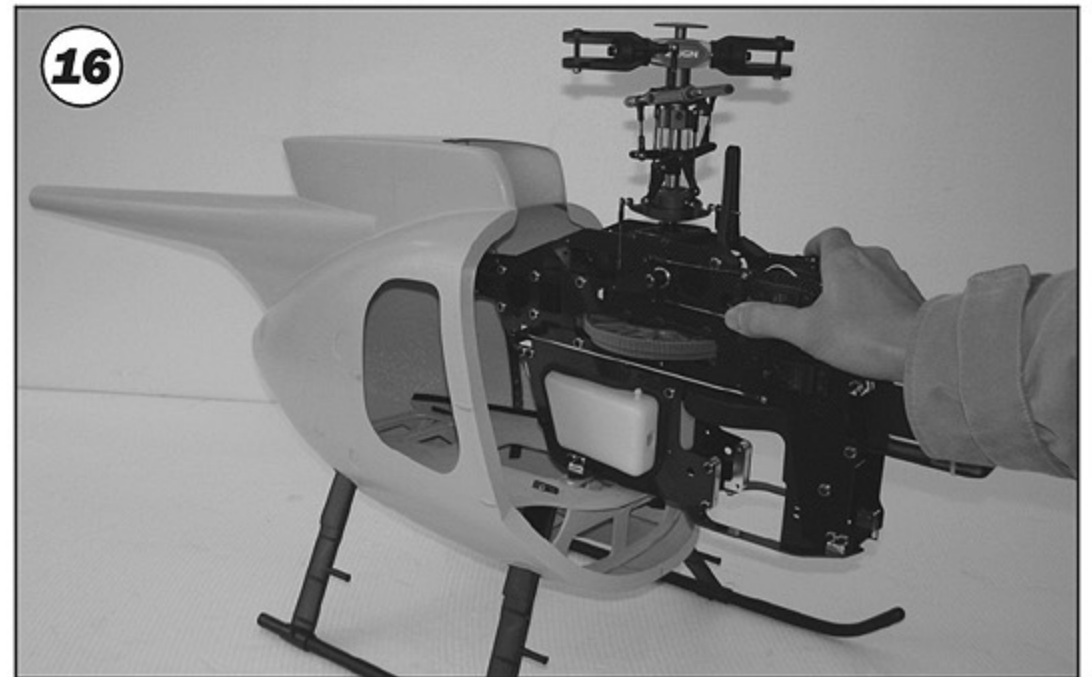

16
Slightly install the helicopter unit into the fuselage.

將機身輕輕裝入機殼。



17
Please note that the control rod C must be passed through the slot of the tail. (TIP: use a thin cotton thread to assist passing the control rod through the slot.)

注意控制桿C須從機殼尾管的缺口穿出（註：可使用較細的棉線輔助，從缺口處拉出控制桿再向外推出來）。

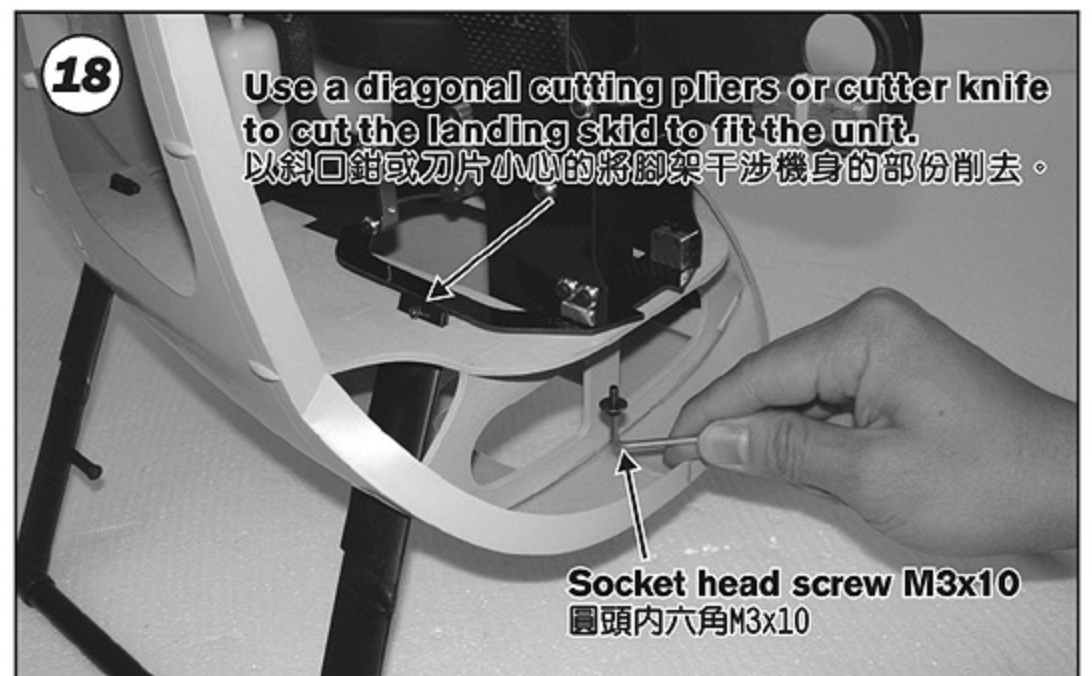

18
Use a diagonal cutting pliers or cutter knife to cut the landing skid to fit the unit.

以斜口鉗或刀片小心的將腳架干涉機身的部份削去。

Fasten the helicopter unit at front with socket head screw M3x10 and washer $\phi 3.4 \times \phi 9.9 \times \phi 0.9 \text{mm}$.
機身前方以圓頭內六角螺絲M3x10與華司 $\phi 3.4 \times \phi 9.9 \times 0.9 \text{mm}$ 鎖緊固定。

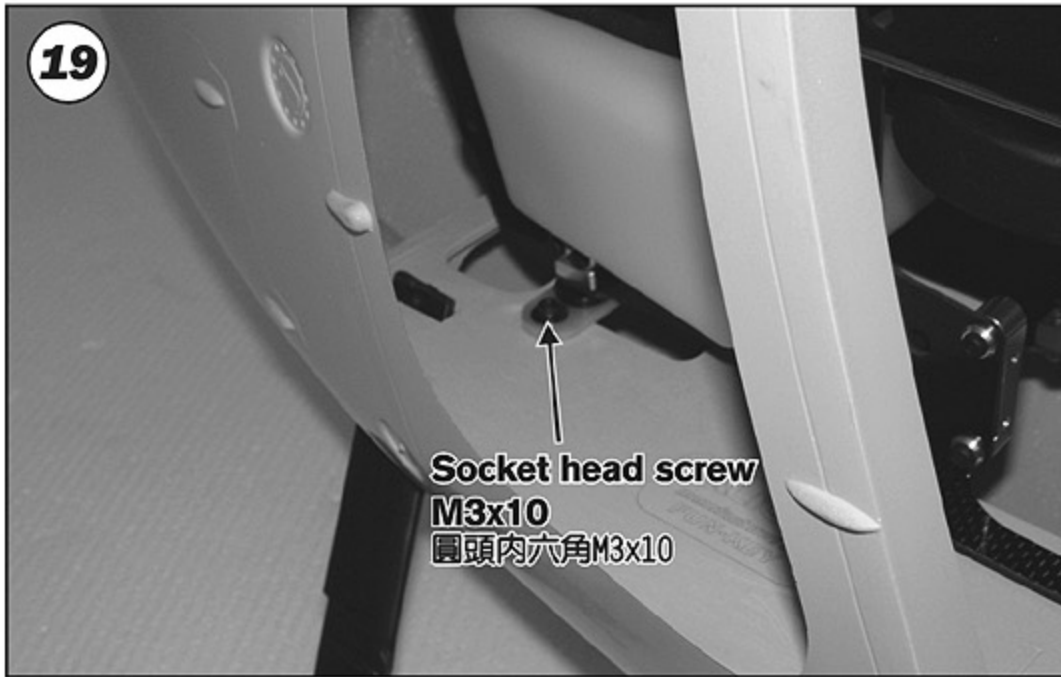

19
 Use a hexagon wrench to fasten the fixing plate with socket head screw M3x10 and washer $\phi 3.4 \times \phi 9.9 \times \phi 0.9 \text{mm}$.
 使用L型的六角扳手將圓頭六角螺絲M3x10與華司 $\phi 3.4 \times \phi 9.9 \times \phi 0.9 \text{mm}$ 將固定片鎖緊固定。

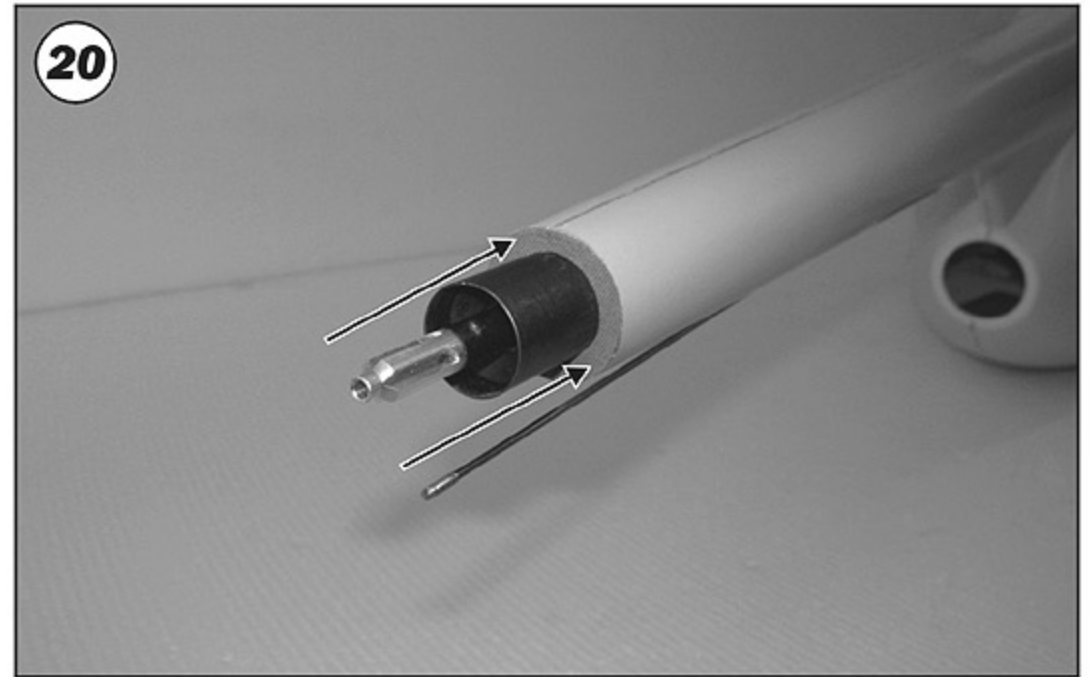

20
 Insert a tail boom guide to the tail boom.
 將尾管固定環套入尾管。

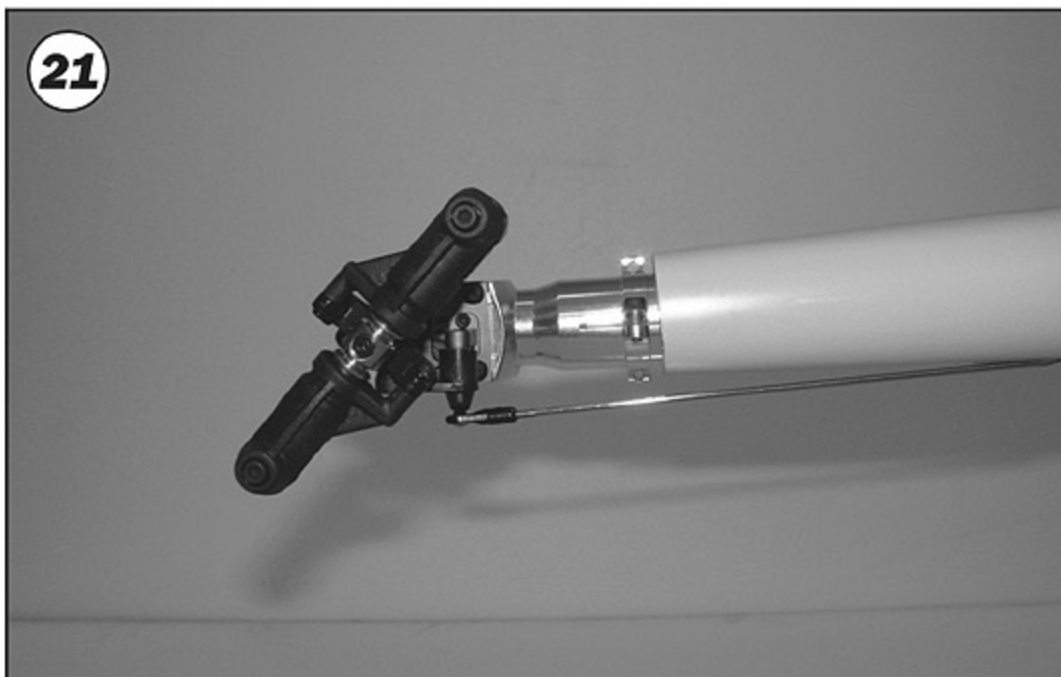

21
 Reinstall the tail case as the standard assembly. Fasten the ball link in a proper position, and then to the linkage ball.
 將尾齒箱組依標準方式裝回，鎖上連桿頭調整至適當長度後，壓入球頭。

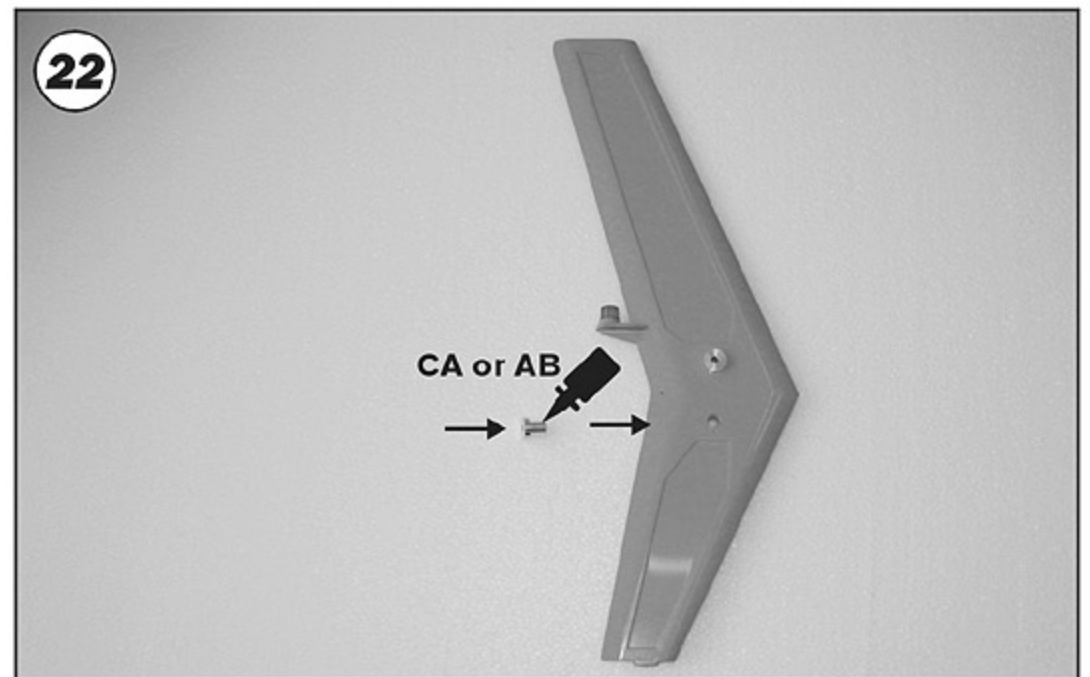

22
 Apply some CA or AB glue on the aluminum inserts and insert into the vertical stabilizer from the right side.
 將垂直翼固定鋁套點上CA或AB膠後，由右側壓入垂直翼。



23
 Fasten the vertical stabilizer with socket head screws M3x16 and washers.
 裝上垂直翼，並以圓頭內六角螺絲M3x16與華司鎖緊固定。

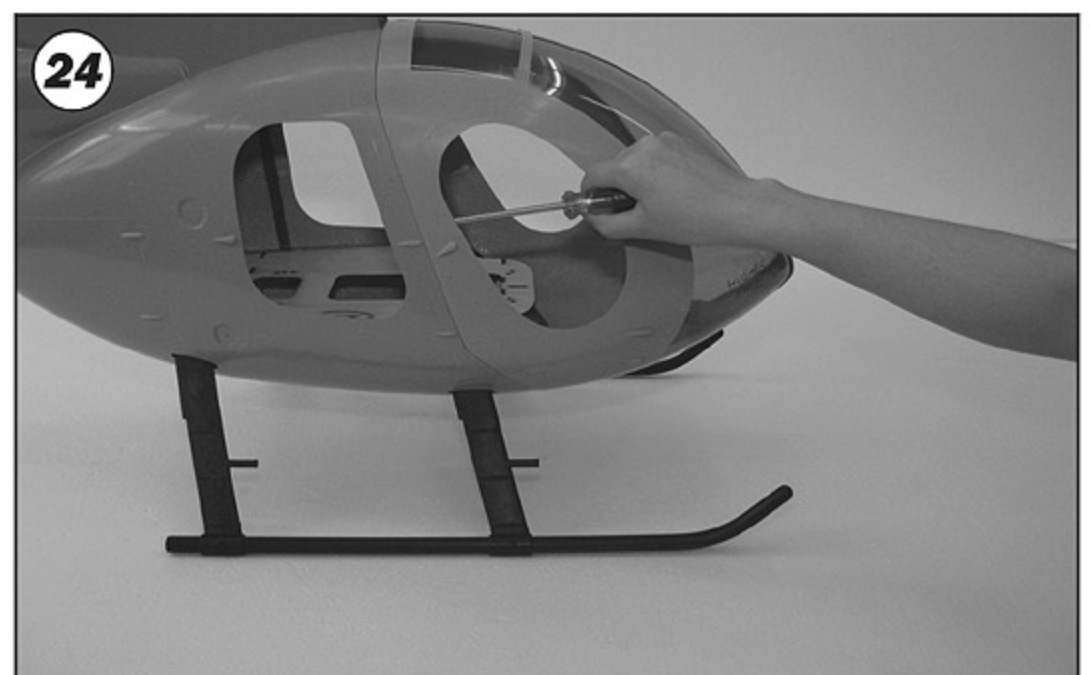

24
 Fasten the canopy with 6pcs round head tapping screws T3x10.
 機頭罩以6pcs圓頭十字螺絲T3x10鎖附固定。



Model:KZ0910102A



Model:KZ0910103A

www.align.com.

www.a

www.align.com

www.align

www.align.com.tw

www.align.

www.align.com.tw



Specifications/規格配備:

Length/機身長: 1230mm

Height/機身高: 500mm

Width/機身寬: 340mm

Weight/空機重: 1200g

Suitable for ALIGN T-REX 600 Nitro series

適合ALIGN T-REX 600 Nitro機型

