

ALIGN INSTRUCTION MANUAL

GP 900 Head Lock Gyro M.E.M.S gyro sensors

Thank you for purchasing the GP900 Gyro. Please read the manual carefully before installing and be sure to retain the manual for future reference.

GP900 is set to 1520 μ s and under DS digital servo mode at the factory. Please make sure your servo type before install the GP900 to avoid any damage due to improper setting. Please read the setting instructions for the setting modification.

ALIGN

GP 900





3D GYRO

The Meaning Of Symbols

 WARNING	Mishandling due to failure to follow these instructions may result in damage or injury.
 CAUTION	Mishandling due to failure to follow these instructions may result in danger.

- Please stop using when anything unusual happens and consult to your seller or experienced pilot.
- Be sure not to store the gyro near any source of heat .
- Please keep the gyro away from moisture or exposure to water.
- Check the gyro everytime after uses to ensure there is nothing damaged.
- If the gyro dropped or get hit, please do not use the gyro and consult to your seller or experienced pilot.

Features

- MEMS** Utilizes MEMS gyro sensors, which feature small footprint, high reliability, and excellent stability.
- 12bit** Sensor with 12 bit ultra high resolution, resulting in highly precise controls.
-  Supports Spektrum and JR satellite receivers.
- S.BUS** Supports Futaba S.Bus architecture.
-  Software upgradable through PC interface adapter.
- Stable** Highly sensitive gyroscopic sensors combined with advanced control detection routine providing higher hovering and aerobatic stability.
- GOV** Built in speed governor function.
-  3.5V~8.4V Capable to operate between 3.5V to 8.4V, compatible with high voltage servos.
-  11g Small footprint, light weight, minimalists and reliable design.
- RoHS** RoHS certified.

Program Setting Table

Setting type	1520/760 μ s	DS/AS	NOR / REV	LIMIT	Helicopter mode / DELAY	Anti-torque compensation
"STATUS"green	▲Standard 1520 μ s Servo	▲Digital servo	▲Normal rotation	Left(Right) Travel limit	Medium/ large heli, suitable for T-REX 500/ 600/700	Right side up mounting: Installed with GP900 label facing up
"STATUS"red	Narrow band 760 μ s Servo	Analog Servo	Reverse rotation	Right(Left) Travel limit	Mini/ Micro heli, suitable for T-REX250/450	Upside down mounting: Installed with GP900 label facing down
Setting instruction	See no. 1 in setting instructions	See no. 2 in setting instructions	See no. 4 in setting instructions	See no. 5 in setting instructions	See no. 6 in setting instructions	See no. 7 in setting instructions

NOTE: 1. "▲"Default setting ◦ 2. Wrong heli mode will affect the performance of gyro. Do not fly before the complete setting.

GP900 HEAD LOCK GYRO SETUP INDICATORS

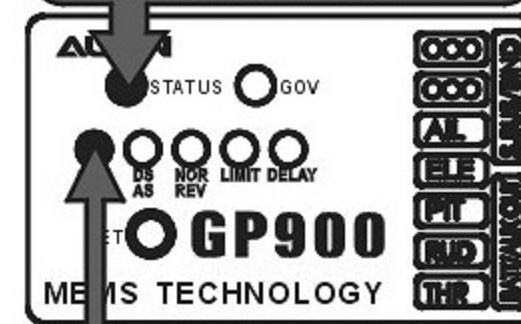
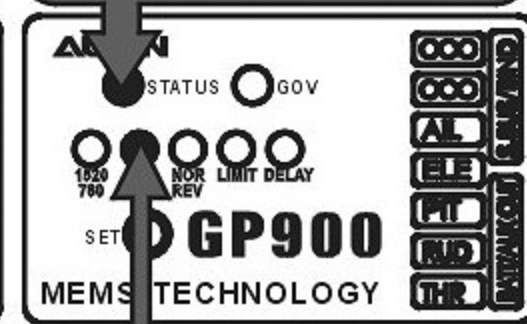
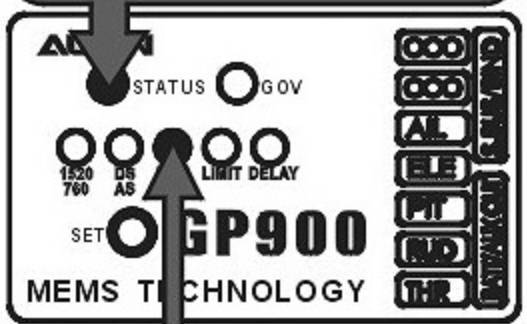
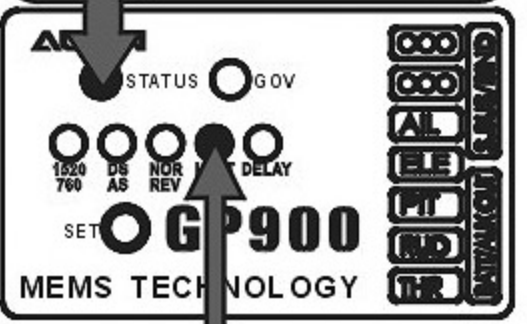
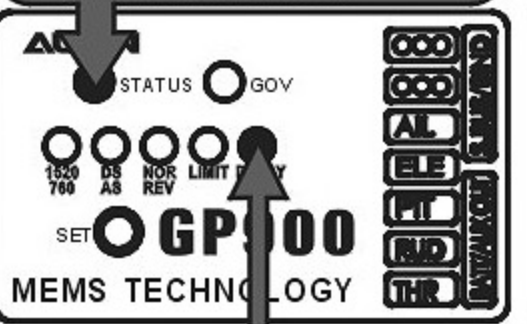
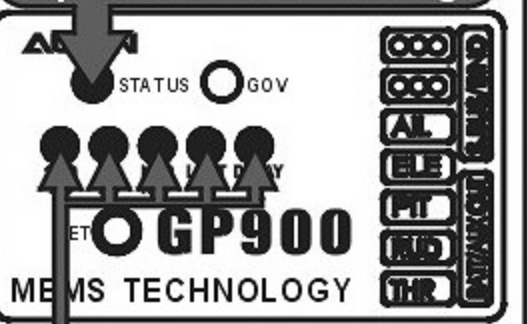
STEP 1	STEP 2	STEP 3	STEP 4	STEP 5	STEP 6
Green: 1520 μ s standard band Red: 760 μ s standard band	Green: Digital Servo Red : Analog Servo	Green: Normal rotation Red: Reverse rotation	The STATUS LED color does not indicate any setting here.	Green: Suitable for T-REX 500/600/700 Red: Suitable for T-REX450/250	Green : right side up mounting Red : upside down mounting
					
Standard/Narrow band setting	DS/AS Setting	Servo NOR/REV Setting	Travel Limit Setting	Helicopter mode /DELAY Setting	Anti-torque compensation direction setting

PARTS IDENTIFICATION

GP900 Head lock gyro

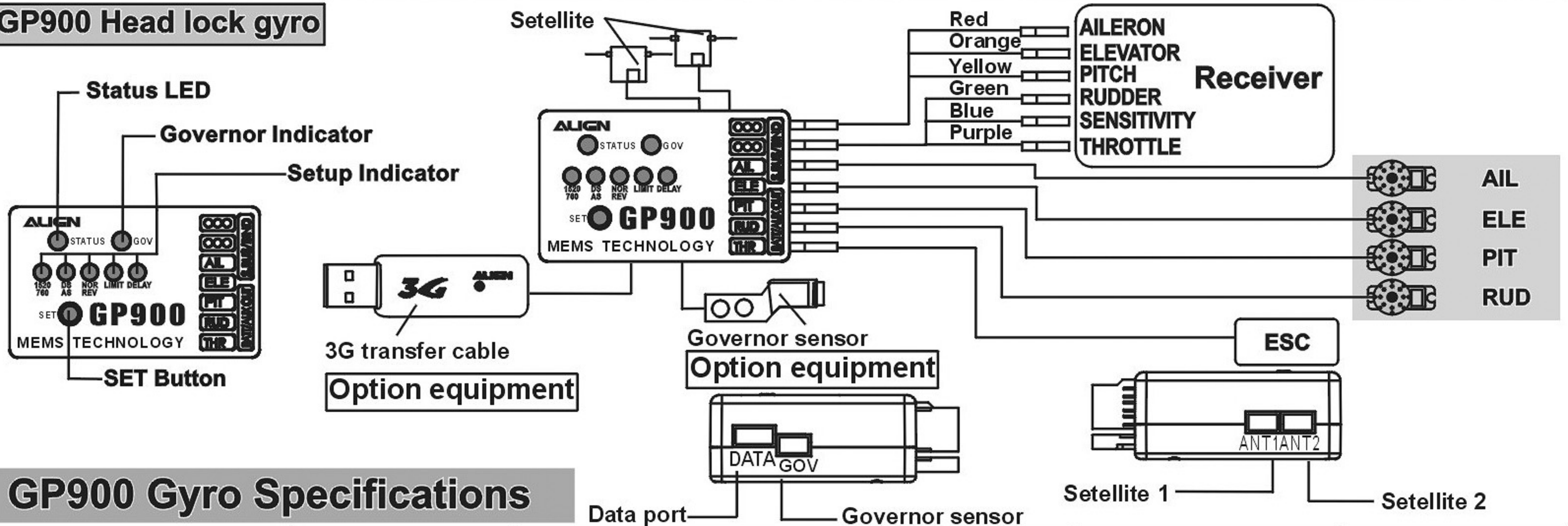

GP900 Gyro Specifications

Operating Voltage	DC 3.5~8.4V	Angular Detection Speed	±600 degrees/sec	Operating Humidity	0%~95%
Current Consumption	<80mA @ 4.8V	Operating Temperature	-20°C~65°C	Size	36.5x25.2x15.6mm
Weight	11g	●RoHS compliant			

Gyro Installation

1. Consult the following diagram for GP900 installation direction. GP900 needs to be mounted flat on gyro mounting platform, away from vibration sources.
 2. Two pieces of foam mounting tape can be used if helicopter experiences vibration induced flight instability. However, if this still doesn't cure the problem, please check the helicopter mechanics and minimize mechanical vibrations, or reduce the headspeed.
 3. Please secure with genuine factory issued double sided anti-vibration mounting tape.
- ※If GP900 was to be mounted inverted (diagram B), please enter connect anti-rorque compensation section and set it as "reverse" (STATUS LED turns red) to avoid the effect of the performance of gyro lock. (Please refer to Page 4)

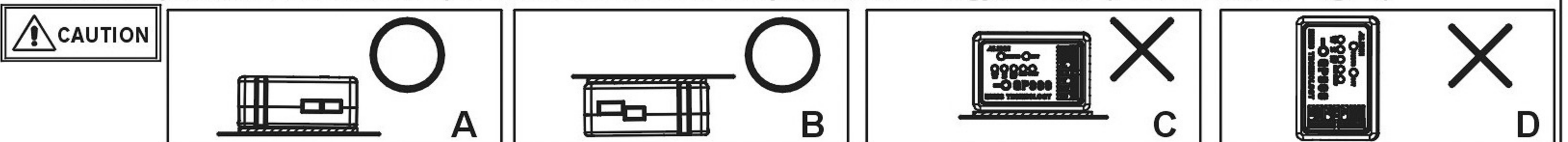

GP900 Connectivity Method

Method 1: Standard receiver connectivity method

1. Connect all wires as shown in diagram. Receiver and GP900 wires are color coded to distinguish the different connection channels. Care should be taken to ensure proper wire color to channel connection.
2. While using the speed controller that not including BEC, you need to connect the BEC power with GP900 "BATT" port.
3. Receiver power is achieved by connecting the GP900 "S.BUS/BIND" port to the channel 7 or BATT port on receiver using supplied signal wire.
4. GP900 has built in speed governor function which can be utilized by purchasing the optional speed sensor. Governor setting is done through channel 7 on the receiver.

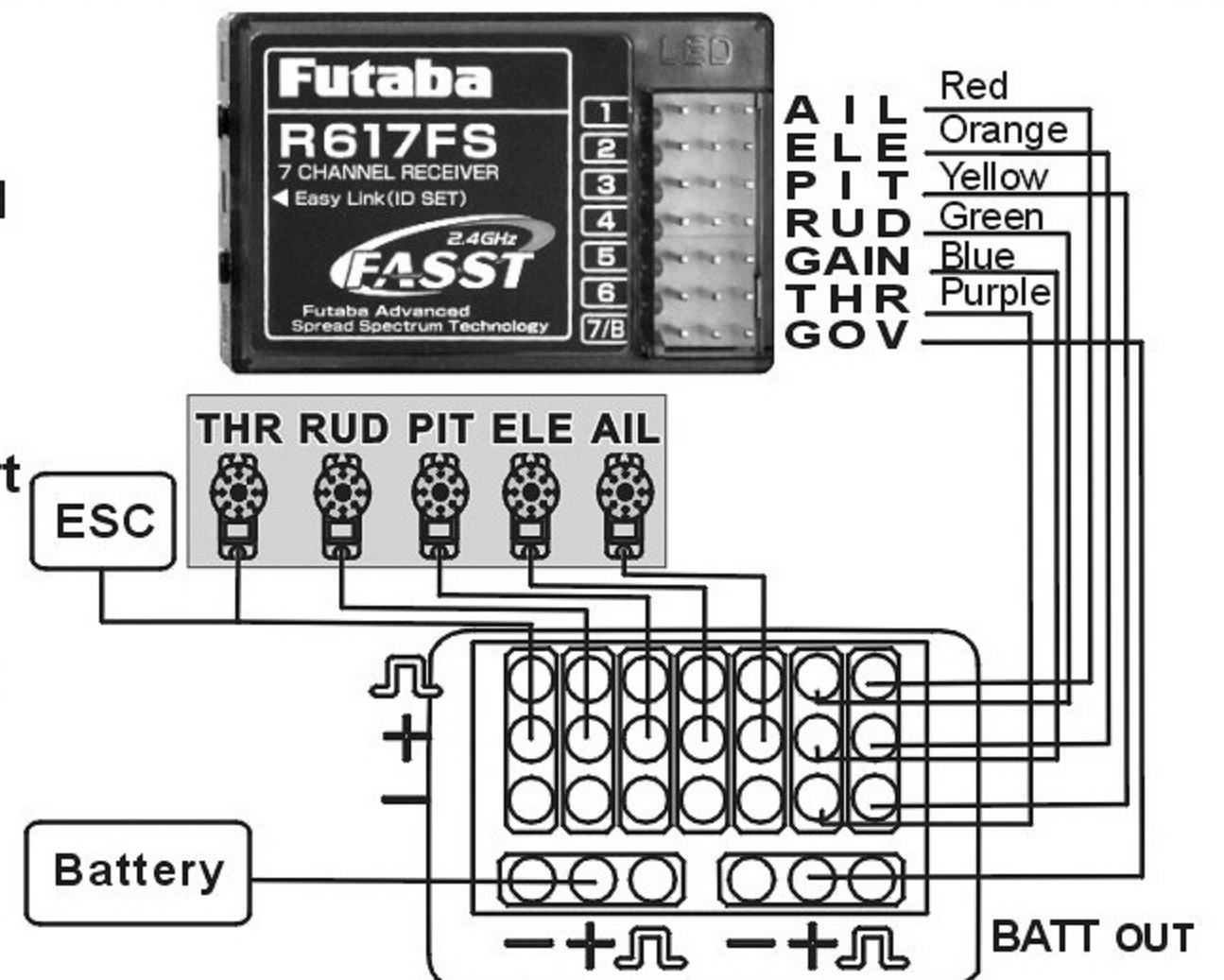

Method 2: Futaba S.BUS Connectivity method

1. For Futaba S.BUS receivers, connect wires as shown in diagram.
2. While using the speed controller that not including BEC, you need to connect the BEC power with GP900 "BATT" port.
3. Receiver power is supplied through S.BUS signal wire connected to GP900's "S.BUS/BIND" port.
4. The default channel/function mapping when using S.BUS are:
 - (1)AIL (2)ELE (3)THR
 - (4)RUD (5)GAIN (6)PIT (7)GOV

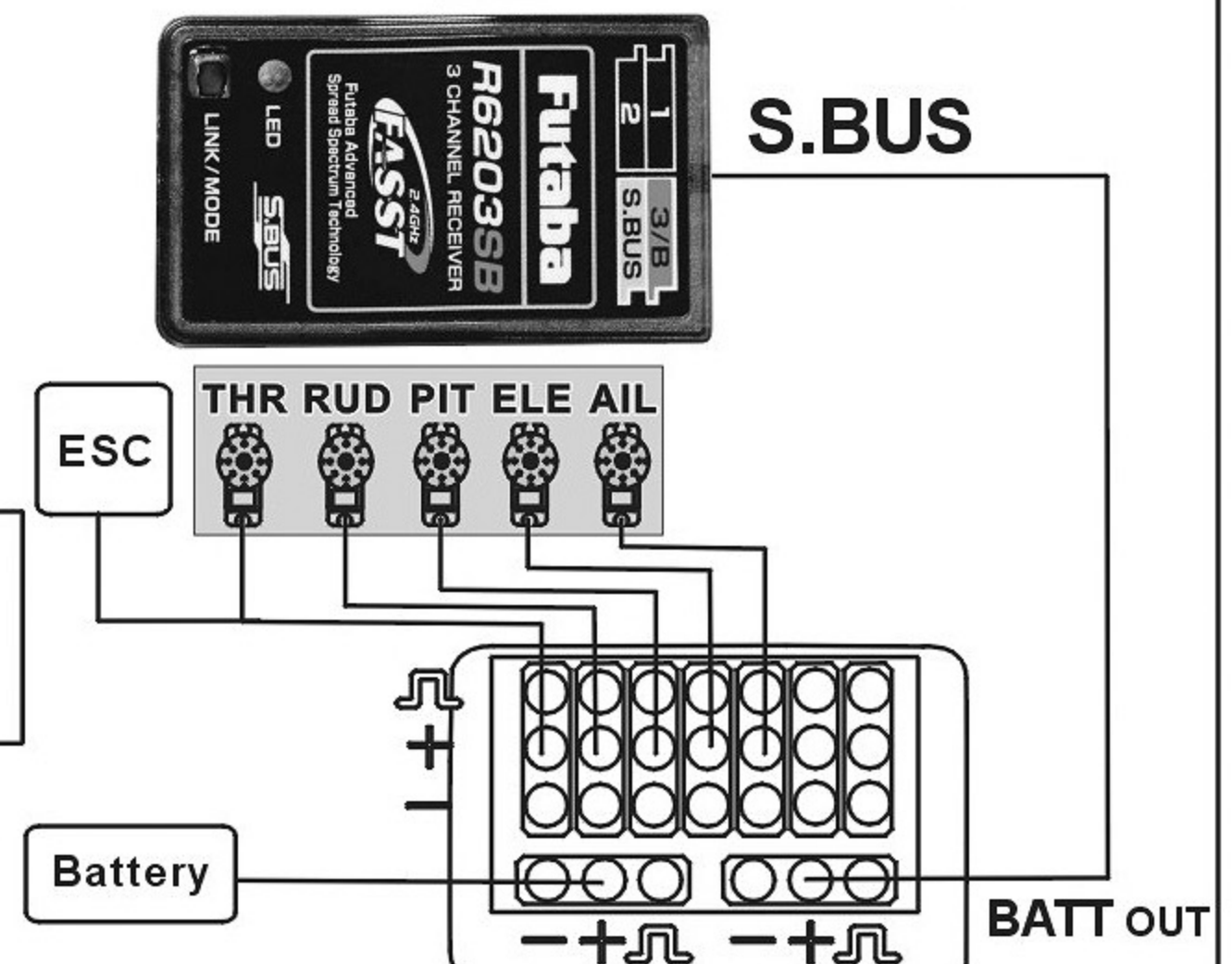

CAUTION If channel 3 is set as PIT and channel 6 set as THR on transmitter, such as 8FG, 12Z, 14MZ, and etc, please reprogram the transmitter to utilize channel 3 as THR and channel 6 as PIT.

5. GP900 has built in speed governor function which can be utilized by purchasing the optional speed sensor. Governor setting is done through channel 7 on the receiver.

Method 3: JR/SPEKTRUM Setellite connectivity method

1. For JR or Spektrum satellite receivers, connect wires as shown in diagram.
2. While using the speed controller that not including BEC, you need to connect the BEC power with GP900 "BATT" port.
3. GP900 has built in speed governor function which can be utilized by purchasing the optional speed sensor. Governor setting is done through channel 7 on the receiver. Channel5/GEAR controls RPM of speed governor, channel7/AUX2 controls rudder gyro gain.
For radios with less than 6 channels, please use the standard receiver connectivity method.
4. For safety concern, two satellite receives should be used, with each antenna perpendicular (90 degrees) from each other. A satellite receiver should be installed on each side of the frame, separate by minimum distance of 5cm.
5. Should both satellite receivers loose connectivity during flight, LED1 ~ LED5 will flash continuously as warning. A single power cycle of the system will not clear this error. The system need to be power cycled the second time to reset.
6. default channel/function mapping when using satellite receiver are:
(1)THR (2)AIL (3)ELE (4)RUD (5)GOV (6)PIT (7)GAIN

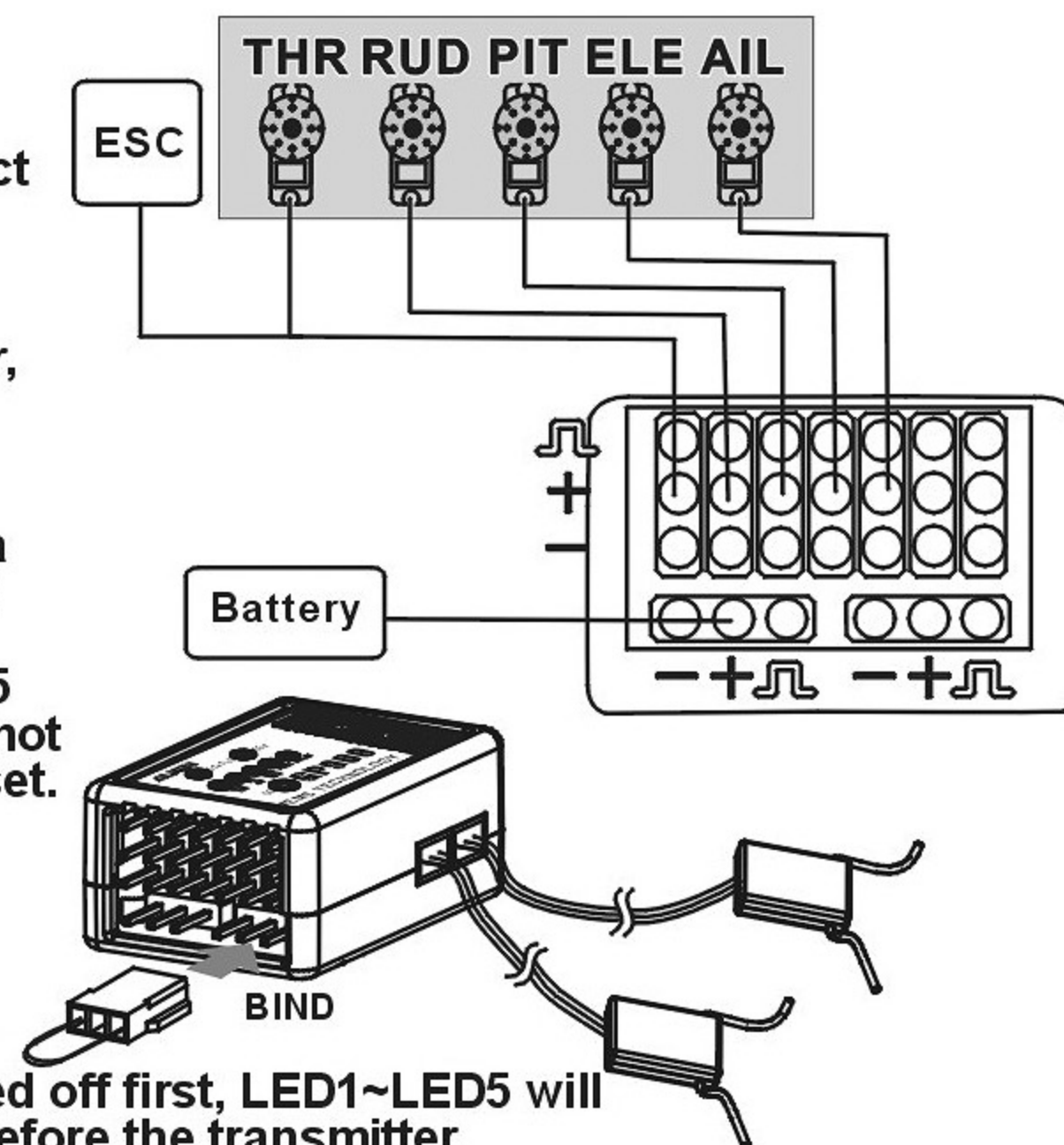

1. Do not mix satellite receivers of different makes.
2. Even under correct startup sequence, if transmitter is powered off first, LED1~LED5 will also flash. Thus the receiver should always be powered off before the transmitter.
3. 3GX supports satellite receiver models currently available on the market. Should new receiver version comes out with compatibility issues, firmware will be updated to resolve any incompatibility that may arise.

Failsafe Setting (Last Position Hold)

When helicopter lost connectivity with your radio under this setting, all channels will hold at the last command position, except throttle channel which goes to a preset position.

1. Push throttle stick to the desired fail safe position.
2. Plug the binding plug into GP900's BIND port, and perform radio binding steps.
3. After successful binding, do not power off the GP900, unplug the binding plug and allow GP900 to enter initializing process. The last position hold function will be active after the GP900 initializes.
4. Test Method: Power off transmitter. The throttle channel should move to preset position, while all other channels should hold in their last position.

Failsafe Setting (Pre-set Position Hold)

When helicopter lost connectivity with your radio under this setting, all channels will move to the pre-set position.

1. Plug the binding plug into GP900's BIND port, and power up the GP900. After the rapid flash of satellite's LEDs, pull the binding plug off.
2. Power up radio transmitter, and perform radio binding steps. After radio is bound, LED on the satellite antennas will end the rapid flash, following by slower flash.
3. Move the transmitter sticks to the desired failsafe position while the LED is flashing in slower mode.
4. Satellite antenna's LED will lit up after 5 seconds, and 3GX goes through initializing process. The failsafe position will be set after the GP900 initializes.
5. Test Method: Power off transmitter, and all channels should move to the pre-set failsafe position.

RUDDER GYRO SETUP

Push and hold the SET button for 2 seconds to enter the rudder gyro setup mode. If your transmitter has the following settings, please disable it or set the value to zero.



GP900 rudder gyro has the factory setting of 1520 μ s and DS digital servo. Double check your servospec and change the gyro setting as needed to avoid damages to the servo.

- ATS
- Pilot authority mixing
- Throttle to rudder mixing
- Rudder to gyro mixing
- Pitch to rudder mixing
- Revolution mixing

1. 1520 μ s (standard) or 760 μ s (narrow band) servo frame rate setup.

GP900 is compatible with both the 760 μ s narrow frame rate servos (such as Futaba S9256, S9251, BLS251), as well as the standard 1520 μ s frame rate servos (most others). Proper frame rate must be selected based on your servo's specifications.

To enter the setup mode : Press and hold the SET button for 2 seconds until STATUS LED flashes. The 1520/760 LED will light up indicating servo frame rate setup mode. Push the transmitter rudder stick left or right to select the frame rate. For example, if rudder is pushed to the left (or right) and STATUS LED turns green, the frame rate is set to 1520 μ s. To set it to 760 μ s, the rudder stick need to be pushed from the center to the opposing end 3 times for the STATUS LED to turn red, indicating frame rate set to 760 μ s.

GP900 panel : Each setting value is labeled on the 3G flybarless control unit with either green or red lettering, which corresponds to the STATUS LED color. Subsequent setup mode is entered by a single press of the SET button. Setup mode will exit if no activity is detected in 10 seconds.

2. DS (digital) / AS (analog) servo selection

There is a direct correlation between servos' speed to gyro's performance. Faster servos are able to execute commands from the gyro at faster and higher precision. Due to the high performance gyro sensors used in the GP900, premium high speed digital rudder servos are mandatory for optimal tail performance. Some of the recommended rudder servos include Align DS650, DS620, DS520, DS420, Futaba S9257, S9256, S9254, S9253, or other servos with similar specifications.

Setup method : Press and hold the SET button for 2 seconds to enter the setup mode, then press the SET button to select DS/AS setup mode, as indicated by the lighting of DS/AS LED. Using the transmitter's rudder stick, select either digital servo DS mode (STATUS LED is green), or analog servo AS mode (STATUS LED is red).

3. Rudder servo direction check and link adjustment

Move the transmitter rudder stick left/right, and check for the correct direction of the rudder servo. If needed, servo reverse is done from the transmitter's REV (reverse) function.

For tail pitch adjustment, center the rudder servo by either setting the GP900 to normal rate mode (non-heading lock), or press and hold the SET button for 2 seconds. With the rudder servo centered and servo horn at 90 degrees, adjust the linkage length until tail pitch slider is centered on the tail output shaft as shown in diagram.

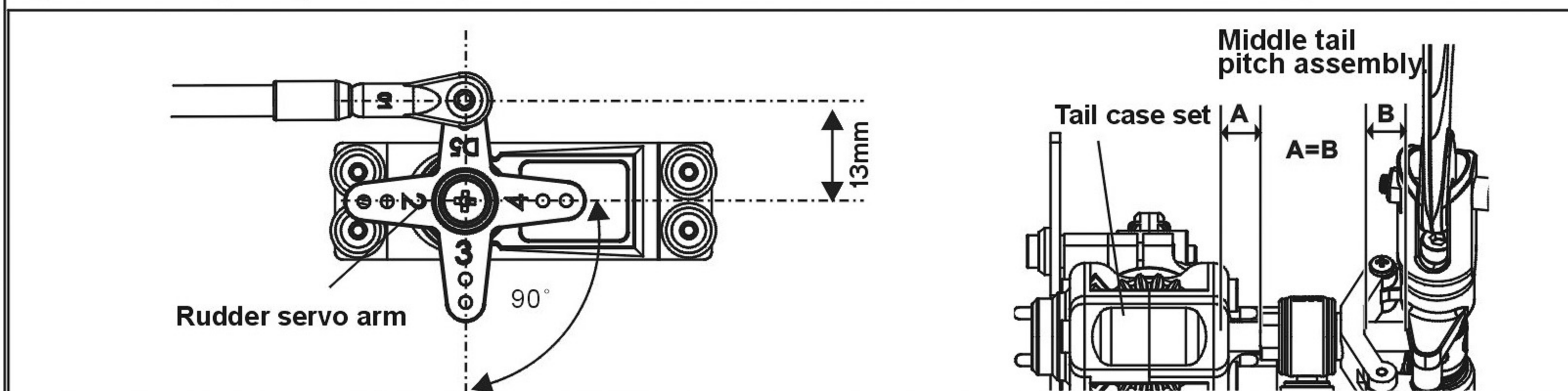

4. Gyro NOR/REV setting: Lift up the helicopter by hand, and turn it to the left (yaw). Check if the rudder servo is applying correct compensation to the right. If reversed, set the NOR/REV setting as follow.

Setup method : Press and hold the SET button for 2 seconds to enter the setup mode, then press the SET button to select NOR/REV setup mode, as indicated by the lighting of NOR/REV LED. Using the transmitter's rudder stick, select either NOR (STATUS LED is green), or REV (STATUS LED is red).

WARNING Flying with reversed gyro will cause the heli to spin out of control. Please double check the direction before attempting to fly the heli.

5. LIMIT rudder servo endpoint setting: Press and hold the SET button for 2 seconds to enter the setup mode, then press the SET button repeatedly to select LIMIT setup mode, as indicated by the lighting of LIMIT LED. Push the transmitter rudder stick left until tail pitch slider reaches the end, then center the rudder stick and wait 2 seconds for the STATUS LED to flash red. Then push the rudder stick right until tail pitch slider reaches the end, then center the rudder stick and wait 2 seconds for the STATUS LED to flash red. This completes the left and right endpoint limit adjustment of servo travel. Insufficient servo travel will degrade helicopter performance, while excessive travel will cause binding and damage rudder servo.

CAUTION To avoid degraded gyro performance as result of insufficient travel range, rudder travel limit setting should not be set to below 50%.

6. Helicopter size and DELAY settings

This setting includes two functions :

(1) For small helicopters such as T-Rex 250/450, set this setting to small helicopter (STATUS LED red). For larger helicopters such as T-Rex 500/550/600/700 set this setting to large helicopter (STATUS LED green).

(2) The DELAY function is utilized when slower rudder servo causes tail hunting (wagging). This can be observed after a hovering pirouette comes to a stop. If tail hunting occurs, gradually increase DELAY value to eliminate it. For best performance, DELAY value should be kept as low as possible without tail hunting.

Setup method : Press and hold the SET button for 2 seconds to enter the setup mode, then press the SET button to select DELAY setup mode, as indicated by the lighting of DELAY LED. The choice of small or large helicopter is done by moving the transmitter rudder stick left or right while observing the color of the STATUS LED. For small helicopters STATUS LED will be red, and large helicopter will be green. The amount of servo delay is set by how far you push the rudder stick, followed by pushing the SET button.

7. Anti Torque Compensation direction setting

To achieve consistent gyro gain on left and right, GP900 has built in anti-torque compensation function. User need to confirm if GP900 is mounted right side up or upside down.

Right side up: Installed with GP900 label facing up, anti-torque compensation set to positive (green STATUS LED).

Upside down: Installed with GP900 label facing down, anti-torque compensation set to negative (red STATUS LED).

Setup method: Press and hold the SET button for 2 seconds to enter setup mode, select until anti-torque compensation section, as indicated by lighting of all 5 setup mode LEDs. Using the rudder stick to select either positive anti-torque compensation (green STATUS LED) for right side up mounting, or negative anti-torque compensation (red STATUS LED) for upside down installation.

8. Sensitivity Adjustment: For radio with built in gyro gain settings, gain can be adjusted directly. For example, 50%-100% setting on the radio translates to 0% - 100% gain in the heading lock mode ; 50%-0% setting on the radio translates to 0%-100% gain in the normal (non-heading) lock mode.

Actual gain value differs amongst servos and helicopters. The goal is to find the maximum gain without tail hunting. This can only be done through actual flight tests.

The recommended starting point for transmitter's gyro gain setting should be 70~80% for hovering, 60~70% for idle-up.

Value should be tuned under actual flight conditions by increasing to the maximum gain without tail hunting.

CAUTION For radios (IE Futaba) using 0-100% as heading lock gain scales, the recommended gain setting is 30% to 35%. For radio that uses the 50 -100% scale (such as JR and Hitec), the recommended gain setting is 70% to 75%.

www.align.com.tw