

# DFC T-REX 450 PLUS INSTRUCTION MANUAL 使用說明書

RH45E01AT

ALIGN

RTF  
READY TO FLY



## Contents

1	INTRODUCTION 前言
1-4	SAFETY NOTES 安全注意事項
5	SAFETY CHECK BEFORE FLYING 飛行前安全檢查重要事項
6-9	PART NAMES AND OPTIONAL PART LIST 各部件名稱與選購配件列表
10-11	SERVO INSTALLATION AND ADJUSTMENT 伺服機組裝與調整
11	ADJUSTMENTS FOR GYRO AND TAIL NEUTRAL SETTING 陀螺儀與尾槳中立點調整
12	INSTALLATION FOR ESC AND BATTERY ESC無刷調速器及電池安裝方式
12	CANOPY ASSEMBLY 機頭罩安裝
13	EQUIPMENT ILLUSTRATION 設備建議配置圖示
14	PITCH AND THROTTLE SETTING 主旋翼螺絲與油门門設定
15-16	TRANSMITTER USAGE AND SETTING/INSTRUCTION 遙控器使用與設定說明
17-25	3GX MRS FLYBARLESS MANUAL 3GX MRS 無平衡槳系統使用說明
26	T8 RADIO CONTROL SYSTEM SETTING T8遙控系統飛行設置表
27	POWER COLLOCATION REFERENCE 機頭動力配置參考表
27-30	ROBLIP BRUSHLESS SPEED CONTROLLER INSTRUCTION MANUAL 無刷調速器使用說明
31-32	3GX MRS FLYBARLESS PREFLIGHT CHECK 飛行前測試程序
32-35	FLIGHT ADJUSTMENT AND SETTING 飛行動作調整與設定
35-36	3GX MRS FLYBARLESS FLIGHT TEST PROCEDURE 飛行測試程序
36	TROUBLESHOOTING 飛行中狀況排除



**3GX MRS**  
Compact  
S-FHSS/DSM2/DSMX

Thank you for buying ALIGN products. The T-REX 450 PLUS DFC is the latest technology in Rotary RC models. Please read this manual carefully before assembling and flying the new T-REX 450 PLUS DFC helicopter. We recommend that you keep this manual for future reference regarding tuning and maintenance.

承蒙閣下選用亞拓遙控世界系列產品，謹表謝意。

進入遙控世界之前必須告訴您許多相關的知識與注意事項，以確保您能夠在學習的過程中較得心應手。在開始操作之前，請務必詳閱本說明書，相信一定能夠給您帶來相當大的幫助，也請您妥善保管這本說明書，以作為日後參考。

Thank you for buying ALIGN Products. The T-REX 450 PLUS DFC Helicopter is designed as an easy to use, full featured Helicopter R/C model capable of all forms of rotary flight. Please read the manual carefully before assembling the model, and follow all precautions and recommendations located within the manual. Be sure to retain the manual for future reference, routine maintenance, and tuning. The T-REX 450 PLUS DFC is a new product developed by ALIGN. It features the best design available on the R/C helicopters market to date, providing flying stability for beginners, full aerobic capability for advanced fliers, and unsurpassed reliability for customer support.

感謝您選購亞拓產品。為了讓您容易方便的使用 T-REX 450 PLUS DFC 直昇機，請您詳細的閱讀完這本說明書之後再進行組裝以及操作這台直昇機。同時請您妥善的保存這本說明書，作為日後進行調整以及維修的參考。T-REX 450 PLUS DFC 是由亞拓自行研發的新產品，不論是需求飛行穩定性的初學者或是追求性能的飛行愛好者，T-REX 450 PLUS DFC 將是您最佳的选择。

### WARNING LABEL LEGEND 標誌代表涵義

	<b>Do not attempt under any circumstances.</b> 在任何禁止的環境下，請勿嘗試操作。
	<b>Mishandling due to failure to follow these instructions may result in damage or injury.</b> 因為疏忽這些操作說明，若使用錯誤可能造成財產損失或嚴重傷害。
	<b>Mishandling due to failure to follow these instructions may result in damage.</b> 因為疏忽這些操作說明，若使用錯誤可能造成危險。

### IMPORTANT NOTES 重要聲明

R/C helicopters, including the T-REX 450 PLUS DFC are not toys. R/C helicopter utilize various high-tech products and technologies to provide superior performance. Improper use of this product can result in serious injury or even death. Please read this manual carefully before using and make sure to be conscious of your own personal safety and the safety of others and your environment when operating all ALIGN products. Manufacturer and seller assume no liability for the operation or the use of this product. This product is intended for use only by adults with experience flying remote control helicopters at a legal flying field. After the sale of this product we cannot maintain any control over its operation or usage.

As the user of this product, you are solely responsible for operating it in a manner that does not endanger yourself and others or result in damage to the product or the property of others.

T-REX 450 PLUS DFC 遙控直昇機並非玩具。它結合了許多高科技產品所設計出來的休閒用品。所以產品的使用不正確或不熟悉都可能會造成嚴重傷害甚至死亡。使用之前請務必詳讀本說明書，並務必注意自身安全。注意！任何遙控直昇機的使用、製造商和經銷商是無法對使用者於零件使用的錯誤與或不當所發生之意外負任何責任。本產品是提供給有操作過模型直昇機經驗的成人或有相當技術的人員在旁指導於當地合法遙控飛行場飛行，以確保安全高度下操作使用，產品售出後本公司概不負任何操作和超出說明書上任何性能與安全責任。

作為本產品的使用者，您，是唯一對於您自己操作的正確及行為負全部的責任之人。

We recommend that you obtain the assistance of an experienced pilot before attempting to fly our products for the first time. A local expert is the best way to properly assemble, setup, and fly your model for the first time. The T-REX 450 PLUS DFC requires a certain degree of skill to operate, and is a consumer item. Any damage or dissatisfaction as a result of accidents or modifications are not covered by any warrantee and cannot be returned for repair or replacement. Please contact our distributors for free technical Consultation and parts at discounted rates when you experience problems during operation or maintenance. As Align Corporation Limited has no control over use, setup, final assembly, modification or misuse, no liability shall be assumed nor accepted for any resulting damage or injury. By the act of use, setup or assembly, the user accepts all resulting liability.

模型產品屬於高操作技術且為消耗性之商品。如經拆裝使用後，會造成不等情況零件損耗，任何使用情況所造成商品不良或不滿意，將無法於保證條件內更換良品或退貨。如請有使用操作經驗經驗，本公司全資分公司或代理商將提供技術指導、特價零件供應服務。對使用者的不當使用、設定、組裝、修改、或操作不良所造成之破壞或傷害，本公司無法控制及負責。任何使用、設定、組裝、修改、或操作不良所造成之破壞、意外或傷害，使用者應承擔全部責任。

### 2. SAFETY NOTES 安全注意事項



· Fly only in safe areas, away from other people. Do not operate R/C aircraft within the vicinity of homes or crowds of people. R/C aircraft are prone to accidents, failures, and crashes due to a variety of reasons including, lack of maintenance, pilot error, and radio interference. Pilots are responsible for their actions and damage or injury occurring during the operation or as a result of R/C aircraft models.

· Prior to every flight, carefully check rotorhead spindle shaft screws and tail blade grip screws, linkage balls and screws, ensure they are firmly secured.

· 遙控模型飛機、直昇機屬高危險性商品，飛行時務必遠離人群，人為組裝不當或零件損壞、電子控制設備不良，以及操控上的不熟悉，都有可能導致飛行失控損傷等不可預期的意外，飛行者務必注意飛行安全，並需了解自負此些所造成任何意外之責任。

· 每趟飛行前須仔細檢查，主旋翼夾頭螺絲、尾旋翼夾頭螺絲，以及機身各部位球頭、螺絲，確實上鎖緊架才能升空飛行。

**LOCATE AN APPROPRIATE LOCATION 遠離障礙物及人群**

RC helicopters fly at high speed, thus posing a certain degree of potential danger. Choose a legal flying field consisting of flat, smooth ground without obstacles. Do not fly near buildings, high voltage cables, or trees to ensure the safety of yourself, others and your model. For the first practice, please choose a legal flying field. Do not fly your model in inclement weather, such as rain, wind, snow or darkness.

真齊飛機飛行時具有一定的速度，相對的也潛在著危險性，場地的選擇也相對的重要。請嚴守當地法規到合法指定飛行場飛行。切勿選擇在建築物、高壓電線或樹木等處飛行。務必注意周圍是否有他人、高樓、建築物、高壓電線、樹木等等，避免操控的不當造成自己與他人財產的損壞。

請勿在下雨、打雷等惡劣天氣下操作，以確保本身及機體的安全。

**NOTE ON LITHIUM POLYMER BATTERIES 鋰聚電池注意事項**

Lithium Polymer batteries are significantly more volatile than alkaline or Ni-Cd/Ni-MH batteries used in RC applications. All manufacturer's instructions and warnings must be followed closely. Mishandling of Li-Po batteries can result in fire. Always follow the manufacturer's instructions when disposing of Lithium Polymer batteries.

鋰聚電池跟一般在RC使用的鹼性電池、鎳鎘電池、鎳氫電池比較起來是相對危險的。請嚴格遵守鋰聚電池說明書之使用注意事項，不恰當使用鋰聚電池，可能造成火災並傷及生命財產安全，切勿大意！

**PREVENT MOISTURE 遠離潮濕環境**

RC models are composed of many precision electrical components. It is critical to keep the model and associated equipment away from moisture and other contaminants. The introduction or exposure to water or moisture in any form can cause the model to malfunction resulting in loss of use, or a crash. Do not operate or expose to rain or moisture.

真齊機內部也是由許多精密的電子零件組成，所以必須絕對的防止讓雨水或水氣，避免在浴室或雨天時使用，防止水氣滲入機身內部導致機件及電子零件故障而引發不可預期的意外！

**PROPER OPERATION 勿不當使用本產品**

Please use the replacement of parts on the manual to ensure the safety of instructors. This product is for RC model, so do not use for other purpose.

請勿自行改造加工，任何的升級或改裝維修，請使用原廠產品保證的零件，以確保結構的安全。請務必於產品說明書內操作，請勿過載使用，並勿用於安全、活動外其它用途。

**OBTAIN THE ASSISTANCE OF AN EXPERIENCED PILOT 避免獨自操控**

Before turning on your model and transmitter, check to make sure no one else is operating on the same frequency. Frequency interference can cause your model, or other models to crash. The guidance provided by an experienced pilot will be invaluable for the assembly, tuning, trimming, and actual first flight or unforeseen danger may happen. (Recommend you to practice with computer-based flight simulator.)

要飛行前飛行前，請確認是否有人與你的模型正在進行飛行，因為頻帶相同頻率的發射器將導致自己與他人模型墜落或炸毀。高經驗飛行師提供的飛行指導將有著一定的難度，盡量避免獨自操作飛行。當有經驗的人士在旁指導，才可以確保飛行，否則將可能造成不可預期的意外發生。(建議電腦模擬器及老手指導是入門必要的選擇)

**SAFE OPERATION 安全操作**

Operate this unit within your ability. Do not fly under tired condition and improper operation may cause in danger. Never take your eyes off the model or leave it unattended while it is turned on. Immediately turn off the model and transmitter when you have landed the model.

請於自己能力內及適當一定技術範圍內操作遙控真齊機，過於疲勞、精神不佳或不當操作，意外發生風險將可能提高。不可在視線範圍外飛行，降落後也請馬上關掉真齊機及遙控器電源。

**ALWAYS BE AWARE OF THE ROTATING BLADES 遠離旋轉中零件**

During the operation of the helicopter, the main rotor and tail rotor will be spinning at a high rate of speed. The blades are capable of inflicting serious bodily injury and damage to the environment. Be conscious of your actions, and careful to keep your face, eyes, hands, and loose clothing away from the blades. Always fly the model a safe distance from yourself and others, as well as surrounding objects.

真齊機主要旋翼與尾旋翼轉動時會以高轉速下運行，在高轉速下的旋翼會造成自己與他在身體上或環境上的嚴重損傷。請勿觸摸旋轉中的主要旋翼與尾旋翼，並保持安全距離以避免造成危險及損傷。

**KEEP AWAY FROM HEAT 遠離熱源**

RC models are made of various forms of plastic. Plastic is very susceptible to damage or deformation due to extreme heat and cold climate. Make sure not to store the model near any source of heat such as an oven, or heater. It is best to store the model indoors, in a climate-controlled, room temperature environment.

遙控飛機、真齊機多半是以 PA 纖維或聚乙稀、電子元件為主要材質，因此要盡量遠離熱源、日曬，以免因高溫而變形甚至熔毀損壞的可能。



## SAFETY ON THE USE OF DRY CELL BATTERIES 乾電池使用安全

The four AA carbon-zinc batteries included with this product are one time use, they should not be recharged for repetitive use. Please read and follow the guidelines below prior to use. The manufacturer cannot be held liable for accidents and damages as result of improper usage.



- These are one time use battery, and should not be recharged.
- Ensure proper polarity and installation method during use.
- Do not mix battery of different age or different model. Doing so may affect battery life, and even cause fire danger.
- If the device is not to be used for long period of time, remove the battery to avoid damage to the transmitter. Do not use the battery should they exhibit symptoms of leak.
- Please follow local law and ordinances when disposing used batteries. Do not dispose them improperly.

本產品所附的4顆3號(AA)碳鋅電池，不可重複充電使用。安裝使用前請務必詳讀並遵照下列事項，本公司將不對任何不當使用所造成的損害及意外負責。

- 本電池為一次性電池，嚴禁重複充電使用。
- 安裝使用時，請確認電池正負極位置及安裝方式。
- 嚴禁將舊或不同型號電池混用，以免影響電池使用壽命，甚至造成電池起火燃燒的危險。
- 產品長時間不使用時，請取出電池，以免造成電池漏液而損害連接器。若電池已經有漏液情況，請勿再繼續使用。
- 廢棄電池，請依照該使用國家或地區的廢棄物清理法令回收，切勿任意丟棄以免汙染環境。



Battery leakage  
電池漏液



## SAFETY ON THE USE OF LITHIUM POLYMER (LI-PO) BATTERIES 鋰聚合物電池使用安全

Lithium batteries have higher degree of risk when compared to other batteries. Please read and follow the guidelines below prior to use. The manufacturer cannot be held liable for accidents and damages as result of improper usage.



- Do not charge past 4.2V/cell; do not discharge past 3.0V/cell.
- Avoid over charging/discharging li-po batteries. Doing so may cause internal damages and affect the battery's discharge performance.
- Avoid continuous use under high temperature environment, or when battery exhibits high temperature. Doing so may shorten battery life, causing puffing of battery, or even danger of explosion.
- Discharge the batteries to 60-70% of full capacity for long term storage. Too low of voltage may result in over-discharging over time. Therefore, we recommend periodic charge of battery in long term storage, this will reduce chance of over-discharge damage.
- To avoid the danger of explosion and fire, use of third party charger to charge these batteries are prohibited.
- Avoid impact, disassembly, incorrect polarity, and burning of batteries. Avoid shorting of battery terminal by metallic objects. Avoid puncture of battery with sharp material.
- Charging error could result in battery explosion, fire, and other unexpected danger or property loss. Please always charge batteries with equipment in sight, do not leave charger unattended. Should you need to leave the charging area, please remove the battery and abort charging process.
- Should the battery exhibit excessive heat after use, do not charge immediately. Doing so may cause battery to puff, deform, explode, or even start a fire.
- Please follow local law and ordinances when disposing used batteries. Do not dispose them improperly.

鋰聚合物電池較其他電池有更高的危險性，使用前請務必遵照下列注意事項，本公司將不對任何不當使用所造成的損害負責。

- 充電時不得高於最大充電電壓4.2V/cell，放電時不得低於最低放電電壓3.0V/cell。
- 嚴禁電池避免過充與過放的情形發生，過充或過放會對電池內部造成損壞並影響電池放電性能。
- 避免在高溫的環境或電池已經產生高溫而繼續使用，這會使電池壽命減短，嚴重者可能會使電池膨脹甚至爆炸的危險。
- 如果長期不用時，請以60%~70%的充電量儲存。電量過低時，可能因自放電導致過放，因此，存放不使用的鋰電池時，建議定期充電，以防止自放電低於最小工作電壓而老化，避免電池充飽存放，充飽存放會導致電池的膨脹。
- 嚴禁使用原廠以外的充電器進行充電，以免發生爆炸起火危險。
- 嚴禁撞擊、拆解、正負極反接、裝填電池，避免金屬物品接觸電池正負極造成短路，並請防止尖銳的物品刺穿電池，以免電池起火危險。
- 充電時務必在視線範圍內進行，不可在無人看管的情形下充電，以免因充電異常造成電池膨脹、燃燒甚至引發火災等不可預期的危險及損失。若需離開看管範圍時應將電池取出，停止對電池充電。
- 電池使用後如有發熱情況，嚴禁充電，否則會造成電池膨脹、變型、爆炸甚至起火燃燒，危害生命財產的安全。
- 廢棄電池，請依照該使用國家或地區的廢棄物清理法令回收，切勿任意丟棄以免汙染環境。

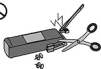

## BALANCE CHARGER SAFETY PRECAUTIONS 充電器使用注意事項



- The device is suitable to 2-3cell, 1000mAh and more lithium batteries. Please do not dismantle or change it for other purpose.
- If there is any unusual deformation of the surface of battery, please do not charge it anymore. If the battery becomes hot while charging, stop charging and check if the battery is broken.
- Do not let this machine drench to the rain/water or uses under the heavy moisture, in order to avoid the interior short-circuits and accidents.
- For short-circuits battery, the indicating light of the charger will be off, so please stop charging.
- Charging error could result in battery explosion, fire, and other unexpected danger or property loss. Please always charge batteries with equipment in sight, do not leave charger unattended. Should you need to leave the charging area, please remove the battery and abort charging process.

- 本充電器適用2-3cell、容量1000mAh以上之鋰電池，請勿自行拆卸、改裝或作為其他用途。
- 外觀已膨脹的電池不可再充電使用；損壞的電池於充電過程中會有發熱的情形，應停止對該電池進行充電。
- 勿讓本機淋到雨水或在重濕氣下使用，以免內部發生短路等不可預期的故障及意外。
- 內部短路的電池，當接上充電器時指示燈會熄滅予以警示，應停止對該電池進行充電。
- 充電時務必在視線範圍內進行，不可在無人看管的情形下充電，以免因充電異常造成電池爆裂、燃燒甚至引發火災等不可預期的危險及損失。若需離開看管範圍時應將電池取出，停止對電池充電。

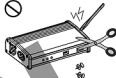

- Do not use the charger at place near heater or expose of sunshine.
- Keep the vent unimpeded.
- While using, put the charger at a stable place and avoid falling down or colliding.

- 避免靠近熱源或電線產品或在陽光直射環境下使用。
- 散熱口須保持暢通不可堵塞，以免影響散熱效果。
- 使用時請放置於平穩的場所並避免碰撞或受到外力衝擊。



- The battery being in use may be a little hot. Please do not charge the battery right away. It might cause the battery broken, even an accident.
- Prevent liquid and anything into the device. If so, please unplug the charger and take out the battery and send it to our distributors to repair.
- Before connecting the charge to batteries, please notice the positive and negative pole of the battery. When the reverse polarity protection beeps, please take out the battery immediately. (The beeps should be stopped in 15 seconds, or the charger will be broken.)
- If there is an unusual temperature increase, swell, or other unusual occurrences, please unplug the battery and AC plug immediately.

- 當電池剛使用過且表面溫度尚未冷卻時，請勿立即充電，否則將造成電池損壞，甚至引發意外。
- 不要讓異物或任何液體進入機體，如有尖銳異物或任何液體進入機體時，請儘快將電源及電池拔除，並送至經銷商或本公司處理。
- 連接電池與充電器之前，請確認電池與充電器的極性是否相符，若極性錯誤將啟動蜂鳴器警示，此時應立即將電池取下（蜂鳴時間約超過15秒，以避免充電器損壞）。
- 當充電過程中發生電池溫度升高、電池膨脹或其他異常情形時，請立即拔掉電池與充電器電源插頭。

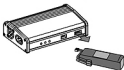











## CAREFULLY INSPECT BEFORE REAL FLIGHT

## 請嚴格執行飛行前檢查義務

- Please read the manual and ALIGN T6 RADIO CONTROL SYSTEM instruction manual before operating. Make sure you understand the basic flight knowledge and other important notes. Also always be conscious of your own personal safety with correct learning process.
- Before flight, please check if the batteries of transmitter and receiver are enough for the flight.
- Before turn on the transmitter, please check if the throttle stick is in the lowest position. IDLE switch is OFF. If they are not, the screen of the transmitter will appear warning beeps until IDLE switch is OFF and throttle stick is in the lowest position.
- When turn off the unit, please follow the power on/off procedure. Power ON- Please turn on the transmitter first, and then turn on receiver. Power OFF- Please turn off the receiver first and then turn off the transmitter. Improper procedure may cause out of control, so please to have this correct habit.
- Before operation, check every movement is smooth and directions are correct. Carefully inspect servos for interference and broken gear.
- Check for missing or loose screws and nuts. See if there is any cracked and incomplete assembly of parts. Carefully check main rotor blades and rotor holders. Broken and premature failures of parts possibly cause resulting in a dangerous situation.
- Check all ball links to avoid excess play and replace as needed. Failure to do so will result in poor flight stability.
- Check the battery and power plug are fastened. Vibration and violent flight may cause the plug loose and result out of control. When IDLE UP throttle curve function is enabled, please be careful and avoid IDLE-UP switch and caused the risk of unexpectedly speed up of the main blades.

- 在開始操作前，請務必詳閱本說明書以及ALIGN T6遙控器說明書，了解基本飛行知識與注意事項後再進行實際操作，以確保飛行安全與正確學習過程。
- 每次飛行前確定您發射機與接收機電池的電量是在足夠飛行的狀態。
- 旋機前請確認門桿是否處於最低點，熄火開關關閉，定速開關(IDLE)是否於關閉位置，當以上開關未於關閉位置與最低點位置，遙控器開機後會出現警告指示與發出警告聲響，直到開關撥回關閉位置與門桿釋放回最低點位置。
- 開機時必須遵守電源開關機程序，開機時應先開發射機後，再開接收機電源；關機時應先關閉接收機後，再開發射機電源。不正確的開關程序可能會造成失控的現象，影響自身與他人的安全，請養成正確的操作。
- 旋機請先確定齒輪機各個動作是否順暢，及方向是否正確，並檢查齒輪器的動作是否有干涉或崩齒的情形，使用故障的齒輪器將導致不可預期的危險。
- 飛行前請確認沒有缺少或鬆動的螺絲與螺帽，確認沒有組裝不完整或損壞的零件，仔細檢查主旋翼是否有損壞，特別是接近主旋翼失速的部位，損壞或組裝不完整的零件不僅影響飛行，更會造成不可預期的危險。注意：對損耗、有裂傷零件更新及定期保養檢查的重要性。
- 檢查所有的連接頭是否有鬆動的情形，過鬆的連接頭應先更換，否則將造成齒輪機無法操作的危險。
- 確認電池及電源插頭是否固定牢固，飛行中的震動或激烈的飛行，可能造成電源插頭鬆脫而造成失控的危險。當遙控器有設置特技飛行模式時，要小心避免不經意的切換到IDLE-UP開關，導致主旋翼突然加速過量產生的危險性。

## STANDARD EQUIPMENT 標準配備

 <p>T-REX 450 PLUS DFC</p>	 <p>ALIGN T6 Radio control system ALIGN T6遙控器</p>	
 <p>11.1V 2200mAh Li-Po Battery 11.1V 2200mAh Li-Po電池</p>	 <p>Lithium Battery Charger 鋰電分壓充電器</p>	 <p>1.5V AA Zinc-Carbon Battery 4號碳鋅電池</p>
 <p>Charger AC Power Cord 充電器電源線</p>	 <p>Hook and Loop fastening tape 電池用魔术帶</p>  <p>Hook and Loop tape 魔术沾</p>	 <p>Binding Plug 對頻金屬</p>  <p>Plastic flat screwdriver 塑膠一字起子</p>



More parts information, specification please refer to Parts Quick Finder at Align Cart.  
<http://shop.align.com.tw/partfinder.php>  
 更多相關零件、規格，請參閱 ALIGN Cart。



**WARNING**  
 警告

Prior to every flight, carefully check rotorhead spindle shaft screws, linkage balls and screws, ensure they are firmly secured.

每起飛前請進行檢查：主旋翼夾座螺絲、螺絲、以及機身各部位球頭、螺絲，確實上緊鎖緊才能安全飛行。



**WARNING**  
 警告

Specifications, contents of parts and availability are subject to change, ALIGN RC is not responsible for inadvertent errors in this publications.

本說明書內的材質、規格或零件包裝之內容物僅供參考，本公司將不對此印刷物之異動負責，也無法主動通知消費者，任何更新或異動，請以亞拓網頁為主。

#### EACH LINKAGE ROD ILLUSTRATION 各連桿示意圖

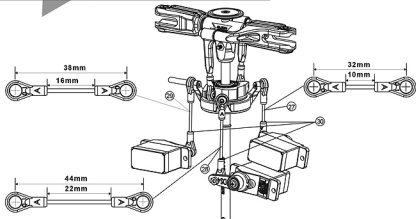

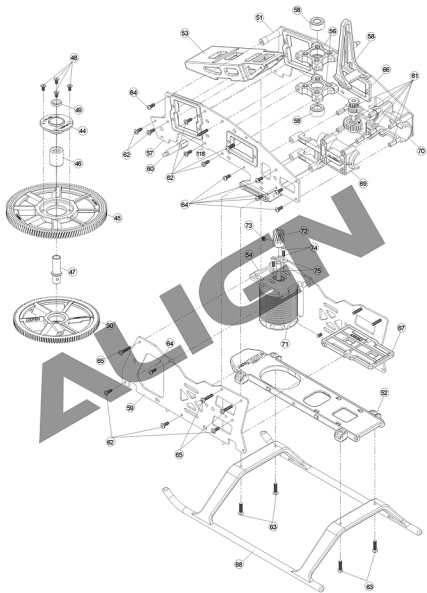



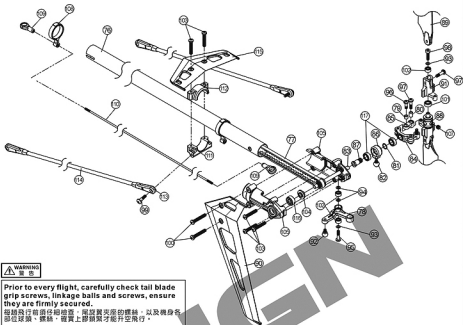

No 項次	Name 名稱	Specification 尺寸	Quantity 數量	No 項次	Name 名稱	Specification 尺寸	Quantity 數量
1	DFC Metal main rotor housing DFC主旋翼固定座		1	19	M2 socket collar screw M2軸套螺絲	M2x16mm	2
2	Feathering shaft 橫軸	φ3xφ4x51mm	1	20	Socket screw 圓錐內六角螺絲	M2x6mm	3
3	Main rotor grip an integrated control linkage set 主旋翼夾座連接組		2	21	M3 Nut M3防鬆螺母	M3	2
4	Main rotor grip linkage bearing sleeve 主旋翼連接軸承套	φ2x3x4.6mm	1	22	Thrust bearing 止推軸承	φ3x3x3.5mm	2
5	DFC Ball link DFC連接桿		2	23	Bearing 軸承	φ4xφ8x3mm	4
6	Main rotor holder 主旋翼夾座		2	24	Bearing 軸承	φ2xφ4.5x2mm	4
7	Collar 橫軸限位套	φ4xφ5.6x1mm	2	25	CCPM Swashplate set 十字盤組		1
8	Damper rubber 橫軸墊圈	φ4xφ6.5x4mm	2	26	M2 Nut M2螺帽		2
9	Metal head stopper(Option equipment) 金屬旋翼限位器(可選裝)		1	27	Linkage rod(M) 連接桿M	φ1.3x22mm	1
10	Main shaft 主軸	φ5x111mm	1	28	Linkage rod 連接桿	φ1.3x35mm	1
11	Long linkage ball 等長長球頭	φ4.75x19.08mm	1	29	Linkage rod (O) 連接桿O	φ1.3x28mm	1
12	325 Carbon fiber blades-blue 325 碳纖維主旋翼-藍	325mm	2	30	450PRO Ball Linkage 450PRO連接桿		6
13	Washer 華司	φ2xφ3.6x0.2mm	2	44	Main gear case 主齒中心殼		1
14	Washer 華司	φ5.5xφ9x0.4mm	2	45	Slant thread main drive gear 121T 斜主齒輪121T	121T	1
15	Washer 華司	φ2xφ6x0.6mm	2	46	One-way bearing 單向軸承	φ8xφ10x12mm	1
16	Linkage ball 球頭A(M2X2.5)	φ4.75x7.10mm	4	47	One-way bearing shaft 單向軸承套	φ5xφ6x21.5mm	1
17	Socket collar screw 圓錐內六角軸套螺絲	M3x16mm	2	48	Cross screw 圓錐十字螺絲	M2x4mm	4
18	M2 socket collar screw M2軸套螺絲	M2x12mm	1	49	One-way Shaft ring 單向軸套圈	φ6xφ8x1.6mm	1

No 項次	Name 名稱	Specification 尺寸	Quantity 數量	No 項次	Name 名稱	Specification 尺寸	Quantity 數量
50	Autorotation tail drive gear 106T 尾驅動主動106T	106T	1	85	Control link 尾控制桿連桿		2
51	Frame mounting bolt 機身固定柱	φ5x22mm	1	86	Bearing holder 尾翼尾輪軸承套		1
52	Bottom plate 底板		1	87	Slide shaft 尾輪滑套	φ4.3xφ4.8x9.6mm	1
53	Battery mount 電池座		1	88	Tail rotor hub 尾旋翼固定座	φ8x17.2mm	1
54	Motor mount 馬達座		1	89	Tail blade 尾旋翼		2
55	Anti rotation bracket 十字鎖導板		1	90	Vertical stabilizer 垂直翼		1
56	Bearing holder 主輪固定座組		2	91	Metal Tail rotor holder 金屬尾旋翼夾座		2
57	Carbon fiber upper frame 碳纖維上側框		2	92	Linkage ball A(M2x2.5) 球頭A(M2x2.5)	φ4.75x7.18mm	1
58	Bearing 軸承	φ5xφ11x5mm	2	93	Washer 華司	φ2xφ3.6x0.2mm	3
59	Carbon fiber lower frame 碳纖維下側框		2	94	Washer 華司	φ2xφ3.6x0.6mm	2
60	Canopy mounting bolt 機罩罩固定柱	φ5x24.5mm	2	95	Collar Screw 軸套螺絲	M2x8mm	1
61	Hexagonal bolt 機身六角螺絲	3x21.8mm	7	96	Collar Screw 軸套螺絲	M2x8mm	2
62	Socket button head self tapping screw 半圓頭內六角自攻螺絲	T2x6mm	18	97	Collar Screw 軸套螺絲	M2x8mm	4
63	Socket button head self tapping screw 半圓頭內六角自攻螺絲	T2x8mm	8	98	Socket Screw 螺頭內六角螺絲	M2x6mm	2
64	Socket button head screw 半圓頭內六角螺絲	M2x5mm	14	99	Socket collar screw 螺頭內六角螺絲鎖母	M2x8mm	4
65	Socket button head screw 半圓頭內六角螺絲	M2x10mm	6	100	Socket button head self tapping screw 半圓頭內六角自攻螺絲	T2x16mm	2
66	Metal tail gear assembly 金屬尾傳動齒輪組		1	101	Bearing 軸承	φ3xφ6x2.6mm	2
67	Gyro mount 陀螺儀固定座		1	102	Bearing 軸承	φ2xφ6x2.5mm	4
68	Landing skid 腳架		1	103	Socket button head self tapping screw 半圓頭內六角自攻螺絲	T2x14mm	5
69	Tail boom mount(R) 尾管固定座(右)		1	104	Metal belt tail pulley cover 金屬皮帶傳動輪蓋		2
70	Tail boom mount(L) 尾管固定座(左)		1	105	Tail unit set(L) 尾齒箱(左)		1
71	Motor 馬達		1	106	Tail unit set(R) 尾齒箱(右)		1
72	Motor pinion helical 11T 馬達齒輪11T	11T	1	107	Set screw 止動螺絲	M3x3mm	1
73	Set screw 止動螺絲	M3x3mm	1	108	Tail control guide 尾控制桿固定套		2
74	Socket screw 螺頭內六角螺絲	M2.5x6mm	2	109	Bill link 滾桿頭		2
75	Washer 華司	φ2.6xφ5.8x0.6mm	2	110	Rudder control screw 尾舵控制連桿	φ1.3x312mm	1
76	Tail boom 尾管	φ12x347mm	1	111	Stabilizer mount(Lower) 水平固定座(下)		1
77	Tail drive belt 皮帶	397MXL	1	112	Stabilizer mount(Upper) 水平固定座(上)		1
78	Tail rotor control arm 尾旋翼控制臂		1	113	Tail boom brace end 尾支撐桿端		4
79	Collar B 尾連桿頭鎖套B	φ2xφ3x2.5mm	2	114	Tail boom brace 尾支撐桿	φ3x290mm	2
80	Collar A 尾連桿頭鎖套A	φ2xφ3x4mm	2	115	Horizontal stabilizer 水平翼		1
81	Collar 尾控制桿軸承座鎖螺絲	φ4xφ5.1x0.3mm	1	116	Bearing 軸承	φ3xφ8x3mm	2
82	Linkage ball E(M2x2.5) 球頭E(M2x2.5)	φ4.75x6.3mm	1	117	Bearing 軸承	φ4xφ7x2.6mm	2
83	Metal tail rotor shaft assembly 金屬尾旋翼主軸	φ3x41mm	1	118	Set screw 止動螺絲	M2x10mm	2
84	T type arm 尾T型控制臂		1				

## SERVO SETTING AND ADJUSTMENT 伺服器設定與調整

FUTABA/ALIGN T6 TRANSMITTER/SERVO FUTABA/ALIGN T6遙控器對應伺服器關係

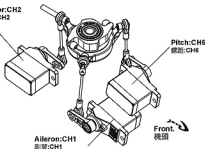
Elevator:CH2  
升降舵:CH2Pitch:CH6  
俯仰:CH6Aileron:CH1  
副翼:CH1Front  
機頭

- Servo can only be installed in this orientation when 3GX MRS is used: with head point forward, right forward is aileron (CH1), left forward is pitch (CH6), mid-rear is elevator (CH2). CH1 and CH6 cannot be interchanged, otherwise helicopter will not function correctly.
- Swashplate type setting on the transmitter should be set to H1 traditional swashplate type. If swashplate movement is incorrect after assembly per instruction, please double check to see if 3GX MRS model setting is set to T-Rex 450 Sport/PLUS DFC.

- 使用3GX MRS 伺服器的安裝方式只有一種。當機頭朝前時，右面為副翼(CH1)；左面為俯仰(CH6)；右後為升降(CH2)。CH1、CH6不可對換。如果說俯仰與副翼對換，直升機動作會不正確。
- 搖控器十字盤設定，必須選擇H1傳統十字盤模式。如果顯示空實完畢，如果十字盤動作不正確，請檢查3GX MRS模型設定是否為T-REX450 SPORT /PLUS DFC。



Check if the screws are firmly tightened before flight.  
飛行前再次確認螺絲是否鎖緊。

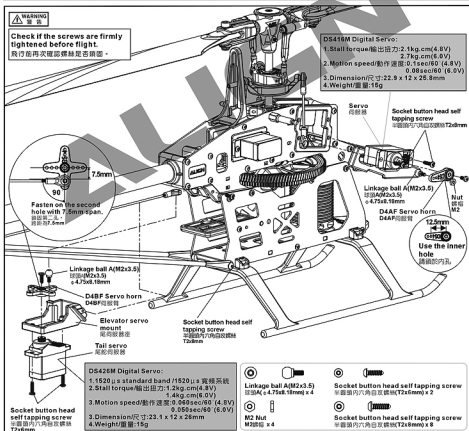

DS416M Digital Servo:

- Stall torque/輸出扭力: 2.1kg.cm (4.8V)  
2.7kg.cm (6.0V)
- Motion speed/動作速度: 0.1sec/60 (4.8V)  
0.08sec/60 (6.0V)
- Dimension/尺寸: 22.9 x 12 x 25.3mm
- Weight/重量: 15g

Servo  
伺服器Socket button head self tapping screw  
平頭圓內六角自攻螺絲 T2x6mmLinkage ball A (M2x3.5)  
球頭A (M2x3.5)  
φ4.75x6.19mmNut  
螺母 M2D4AF Servo horn  
D4AF伺服臂12.5mm  
Use the inner hole  
請鎖於內孔Linkage ball A (M2x3.5)  
球頭A (M2x3.5)  
φ4.75x6.19mmD4BF Servo horn  
D4BF伺服臂Elevator servo mount  
尾向伺服座Tail servo  
尾舵伺服器Socket button head self tapping screw  
平頭圓內六角自攻螺絲 T2x6mm

DS426M Digital Servo:

- 1520 μs standard band / 1520 μs 寬頻系統
- Stall torque/輸出扭力: 1.2kg.cm (4.8V)  
1.4kg.cm (6.0V)
- Motion speed/動作速度: 0.069sec/60 (4.8V)  
0.059sec/60 (6.0V)
- Dimension/尺寸: 23.1 x 12 x 26mm
- Weight/重量: 15g

Socket button head self tapping screw  
平頭圓內六角自攻螺絲 T2x6mmLinkage ball A (M2x3.5)  
球頭A (φ4.75x6.19mm) x 4M2 Nut  
M2螺母 x 4Socket button head self tapping screw  
平頭圓內六角自攻螺絲 (T2x6mm) x 2Socket button head self tapping screw  
平頭圓內六角自攻螺絲 (T2x6mm) x 8

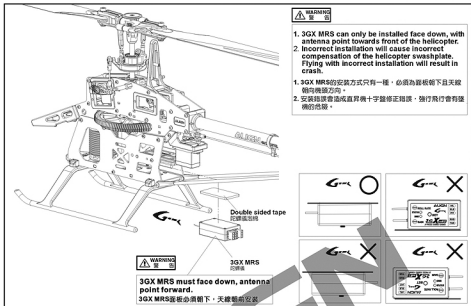

## 6. ADJUSTMENTS FOR GYRO AND TAIL NEUTRAL SETTING 陀螺儀與尾翼中立點設定調整

ALIGN

Turn off Revolution mixing (RVMX) mode on the transmitter, then set the gain switch on the transmitter and the gyro to Head lock mode. The gain setting is about 45%, and after transmitter setting, connect to the helicopter power for working on tail neutral setting.

**Note:** When connecting to the helicopter power, please do not touch tail rudder stick and the helicopter. Then wait for 3 seconds, make tail servo horn and tail servo at a right angle (90 degrees), tail pitch assembly must be correctly fixed about in the middle of the travel of tail rotor shaft for standard neutral setting.

發射器內陀螺儀設定請關閉混控模式，並將發射器上的增益開關與陀螺儀切至鎖定模式，感度設約45%左右，發射器設定完成後接上直昇機電源，即可進行尾中立點設定。

注意：當接上直昇機電源時請勿動尾舵桿或碰觸機體，待3秒陀螺儀鎖定後尾伺服桿需與尾伺服器的成90度，尾設置控制組須正確置於尾槳軸行程的中間位置，即為標準尾中立點設定。

### TAIL NEUTRAL SETTING 尾中立點設定

After setting Head Lock mode, correct setting position of tail servo and tail pitch assembly is as photo. If the tail pitch assembly is not in the middle position, please adjust the length of rudder control rod to trim.

陀螺儀鎖定後尾伺服桿與尾Pitch控制組正確設置位置，若尾Pitch控制組未居中時請調整尾控制連桿的長度來修正。

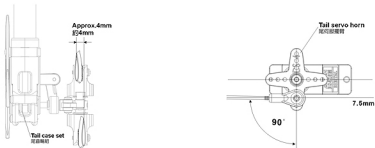

## ESC INSTALLATION ESC無刷調速器安裝方式

NOTE: When installing the speed controller, please keep a distance at least 5cm from the receiver to avoid any interference.

注意：安裝ESC時請與接收器保持至少5cm以上的距離，避免干擾接收器。

ESC installation location  
ESC安裝位置

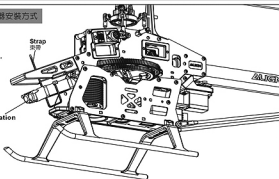

## BATTERY INSTALLATION 電池安裝方式

Use attached Hoop and Loop Tape, tape the Hoop side (hooked) on the battery mounting plate and the Loop side (fuzzy) on the battery to fix the battery in order to prevent any slip.

以附贈的魔術粘膠帶，將公頭的魔術粘(勾狀)黏貼於電池座上，母頭的魔術粘(絨毛狀)黏貼於電池上，可有效固定電池避免滑動。

Hook and Loop Tape (fuzzy)  
魔術粘母頭

Hook and Loop Tape (hooked)  
魔術粘公頭

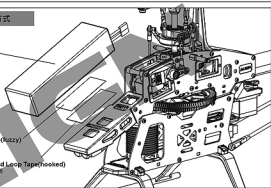

## 8. CANOPY ASSEMBLY 機頭罩安裝

Canopy  
機頭罩 x 1

Canopy nut  
機頭罩墊圈 x 2

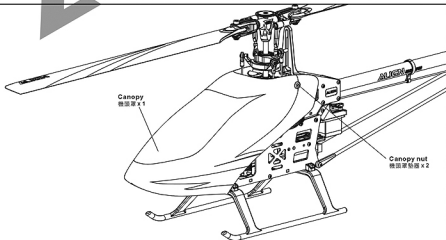

3GX MRS WIRING DIAGRAM 3GX MRS 接收器接線示意圖

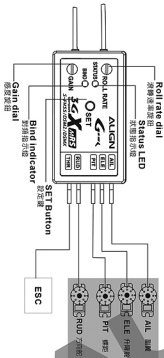
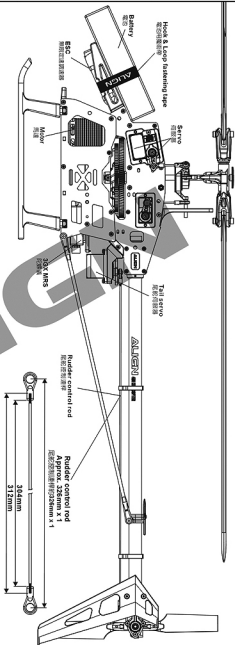

Gain and roll rate dials are set to 50% as factory default (dial at 12 o'clock position, same direction as the antenna). Should there be any oscillation on aileron or elevator during flight, reduce the gain by turning the dial counter-clockwise approximately 10 degrees at a time.

Should there be any drift front/rear/left/right during flight, increase the gain by turning the dial clockwise approximately 10 degrees at a time.

Roll rate dial is used to adjust the roll rate of helicopter's elevator and aileron; turning clockwise will increase roll rate, with faster elevator roll rate, with slower elevator and aileron response. We recommend novice pilots to fly with lower roll rate.

此圖為接收器接線圖，出廠設定值為50%（收線器12點鐘方向，天線位置為12點鐘方向），飛行時若有左右或前後抖動，表示感度偏高，請逆時針調整感度為50%。若由天線感度10度方式，調整感度為50%。

飛行時若發現有左右或前後抖動，表示感度偏高，請逆時針調整感度為50%。以每次10度方式調整感度。

此圖為接收器接線圖，出廠設定值為50%（收線器12點鐘方向，天線位置為12點鐘方向），飛行時若有左右或前後抖動，表示感度偏高，請逆時針調整感度為50%。若由天線感度10度方式，調整感度為50%。

## GENERAL FLIGHT 一般飛行模式

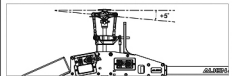
Stick position at high/Throttle 100%/Pitch +9°  
搖桿高速/油門 100%/螺距 +9°Stick position at Hovering/Throttle 65%/Pitch +5°  
搖桿停滯/油門 65%/螺距 +5°Stick position at low/Throttle 0%/Pitch -1°~0°  
搖桿低速/油門 0%/螺距 -1°~0°

## 3D FLIGHT 3D 特技飛行模式

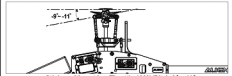
Stick position at high/Throttle 100%/Pitch +9°~+11°  
搖桿高速/油門 100%/螺距 +9°~+11°Stick position at middle/Throttle 90%/Pitch 0°  
搖桿中速/油門 90%/螺距 0°Stick position at low/Throttle 100%/Pitch -9°~-11°  
搖桿低速/油門 100%/螺距 -9°~-11°

1. Pitch range: Approx. 25 degrees.
2. If the pitch is set too high, it will result in shorter flight duration and poor motor performance.
3. Setting the throttle to provide a higher speed is preferable to increasing the pitch too high.

1. 螺距 (Pitch) 飛行約 25°
2. 過大螺距設定，會導致動力與飛行時間降低。
3. 動力提升以較高轉速的設定方式，優於螺距過大的設定。

## GENERAL FLIGHT 基本飛行模式

(Default Setting 出廠設定值)

Throttle 油門	Pitch 螺距
5 100% High speed 100% 高速	+9°
4 85%	
3 65% Hovering 65% 停滯	+5°
2 44%	
1 0% Low speed 0% 低速	-1°~0°

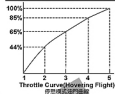

## PITCH AND ROTATION SPEED 螺距與轉速

TIP: It is recommended to use a lower pitch setting when using higher RPM Head speed. This will allow for better power.

※配要領：如要使用較高轉速動力建議配低螺距 Pitch，而獲得較佳動力效能。

Excessive pitch or too low of head speed may induce wobbling of helicopter during hovering.

過大 Pitch 設定及轉速過低設定，於停滯狀態導致飛行時機震盪後晃動。

## IDLE 1: SPORT FLIGHT

Throttle 油門	Pitch 螺距
5 100%	+9°~+11°
4 85%	
3 80%	+5°
2 85%	
1 90%	-6°

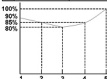

Throttle Curve (Simple Aerobatic Flight) 空中飛行模式油門曲線

## IDLE 2: 3D FLIGHT

(Default Setting 出廠設定值)

Throttle 油門	Pitch 螺距
5 100% High 90% 高	+9°~+11°
3 30% Middle 90% 中	0°
1 100% Low 90% 低	-9°~-11°

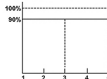

Throttle Curve (3D Flight) 特技飛行模式油門曲線

T-REX 450 PLUS DFC BTF ( Bind To Fly ) complete package was assembled and tuned at the factory, including all parameters in the 3GX MRS flybarless system. Just use your capable of binding with Spektrum DSM2/DSMX and JR DSM2 radios, complete the following transmitter settings, and bind it to start flying.

T-REX 450 PLUS DFC BTF ( BIND TO FLY ) 整機全部是由原廠組裝調整完成，其中包括 3GX MRS 無平衡翼系統所有的參數設定，您只要搭配 S-FHSS 2.4GHz 系統遙控器或 SPEKTRUM DSM2/DSMX、JR DSM2 衛星天線遙控器，並完成下列遙控器設定以及對頻就可以飛行了。

### 1. COMPATIBLE TRANSMITTER 適用遙控器：

The 3GX MRS flybarless system in the T-REX 450 PLUS DFC BTF contains a built in S-FHSS 2.4GHz receiver, and is compatible only with similar S-FHSS transmitter. In addition, 3GX MRS also supports the use of satellite receivers, capable of binding with Spektrum DSM2/DSMX and JR DSM2 radios.

T-REX 450 PLUS DFC BTF 所搭配的 3GX MRS 無平衡翼系統，內建 S-FHSS 2.4GHz 接收模組，必須選擇一樣為 S-FHSS 2.4GHz 系統的遙控器才能對頻使用。另外，3GX MRS 也支援衛星天線使用，可以搭配 SPEKTRUM DSM2/DSMX 與 JR DSM2 衛星天線遙控器對頻使用。

Use S-FHSS 2.4GHz transmitter  
使用 S-FHSS 2.4GHz 系統

Using Spektrum DSM2/DSMX and JR DSM2 Radio's Satellite Receivers  
使用 Spektrum DSM2/DSMX、JR DSM2 衛星天線遙控器



### 2. SELECT H-1 SWASHPLATE TYPE 選擇 H-1 十字盤類型：

3GX MRS supports H-1 type swashplate layout. Set the swashplate mode to H-1 in the transmitter's setting. If swashplate type is not set properly, the control movement will not be correct, making the helicopter unflyable.

3GX MRS 支援的十字盤類型為 H-1 十字盤。選擇將遙控器的十字盤選項，設定為 H-1 十字盤類型。如果十字盤選擇錯誤，會造成直升機動作不正確無法飛行。

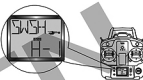

### 3. TRANSMITTER SETUP PARAMETERS DIAGRAM 遙控器設定表：

T-REX 450 PLUS DFC already has all 3GX MRS parameters configured at the factory. Just follow the diagram below and enter all parameters into the transmitter and bind the radio, the helicopter will be ready to fly. The parameters in diagram below is suitable for beginners and general 3D flying, but can be adjusted to suit personal flying preference.

T-REX 450 PLUS DFC 出廠的已經完成 3GX MRS 所有設定，只要將下表的遙控器各項參數輸入到遙控器中，以及完成對頻動作就可以進行飛行。下表參數適用初學基礎飛行以及一般 3D 飛行使用，您也可以依照個人飛行習慣來調整遙控器參數。

	AIL 副翼	ELE 升降	THR 油門	RUD 尾舵	GYRO 陀螺	PIT 傾倒
Servo Reverse 伺服器正反转	Normal 正向	Normal 正向	Reverse	Normal 正向	Normal 正向	Normal 正向
D / R 懸臂比率	▲ 100 %	▲ 100 %		▲ 100 %		
	▼ 100 %	▼ 100 %		▼ 100 %		
EXP 動作曲線	▲ -30 %	▲ -30 %		▲ -15 %		
	▼ -30 %	▼ -30 %		▼ -15 %		
End Point Adjust 伺服器行程量	▲ 100 %	▲ 100 %	▲ 100 %	▲ 100 %	▲ 100 %	▲ 60 %
	▼ 100 %	▼ 100 %	▼ 100 %	▼ 100 %	▼ 100 %	▼ 60 %

Swash type  
十字盤類型

H-1

	Normal flight / 一般飛行			Normal flight / 3D 飛行		
	45 % (AVCS)			40 % (AVCS)		
Gyro gain 尾舵感度						
Normal Throttle Curves 一般飛行油門曲線	P1	P2	P3	P4	P5	
Normal Pitch Curves 一般飛行傾倒曲線	0 %	44 %	65 %	85 %	100 %	
IDLE-UP Throttle Curves 3D 飛行油門曲線	P1	P2	P3	P4	P5	
IDLE-UP Pitch Curves 3D 飛行傾倒曲線	44 %	52 %	74 %	84 %	93 %	
	P1	P2	P3	P4	P5	
	90 %	90 %	90 %	90 %	90 %	
	P1	P2	P3	P4	P5	
	0 %	25 %	50 %	75 %	100 %	



**Spektrum System SPEKTRUM 系統**

	THR 油门	ELE 升降	AIL 偏航	RUD 尾舵	GYRO 陀螺	PIT 螺距
Servo Reverse 伺服器正反轉	Normal 正向	Reverse 反向	Reverse 反向	Reverse 反向	Normal 正向	Reverse 反向
D / R 雙量比率		▲ 100 % ▼ 100 %	▲ 100 % ▼ 100 %	▲ 100 % ▼ 100 %		
EXP 動作曲線		▲ 30 % ▼ 30 %	▲ 30 % ▼ 30 %	▲ 15 % ▼ 15 %		
End Point Adjust 伺服器行程量	▲ 100 % ▼ 100 %	▲ 100 % ▼ 100 %	▲ 100 % ▼ 100 %	▲ 100 % ▼ 100 %	▲ 100 % ▼ 100 %	▲ 60 % ▼ 60 %

Swash type 十字盤類型	1-Servo-Normal					
Gyro gain 陀螺感度	Normal flight / 一般飛行 55 %			3D flight / 3D 飛行 50 %		
Normal Throttle Curves 一般飛行油门曲線	P1	P2	P3	P4	P5	
	0 %	42 %	65 %	78 %	100 %	
Normal Pitch Curves 一般飛行螺距曲線	P1	P2	P3	P4	P5	
	44 %	52 %	74 %	84 %	93 %	
IDLE-UP Throttle Curves 3D 飛行油门曲線	P1	P2	P3	P4	P5	
	90 %	90 %	90 %	90 %	90 %	
IDLE-UP Pitch Curves 3D 飛行螺距曲線	P1	P2	P3	P4	P5	
	0 %	25 %	50 %	75 %	100 %	



These are the standard channel mapping when satellite receivers are used.

(1) THR (2) AIL (3) ELE (4) RUD (5) GAIN (6) PIT

使用衛星天線時，內部通道已指定為：(1) THR (2) AIL (3) ELE (4) RUD (5) GAIN (6) PIT

**JR System JR 系統**

	THR 油门	ELE 升降	AIL 偏航	RUD 尾舵	GYRO 陀螺	PIT 螺距
Servo Reverse 伺服器正反轉	Normal 正向	Reverse 反向	Reverse 反向	Reverse 反向	Normal 正向	Reverse 反向
D / R 雙量比率		▲ 100 % ▼ 100 %	▲ 100 % ▼ 100 %	▲ 100 % ▼ 100 %		
EXP 動作曲線		▲ 30 % ▼ 30 %	▲ 30 % ▼ 30 %	▲ 15 % ▼ 15 %		
End Point Adjust 伺服器行程量	▲ 100 % ▼ 100 %	▲ 100 % ▼ 100 %	▲ 100 % ▼ 100 %	▲ 100 % ▼ 100 %	▲ 100 % ▼ 100 %	▲ 60 % ▼ 60 %

Swash type 十字盤類型	1-Servo-Normal					
Gyro gain 陀螺感度	Normal flight / 一般飛行 75 %			3D flight / 3D 飛行 70 %		
Normal Throttle Curves 一般飛行油门曲線	P1	P2	P3	P4	P5	
	0 %	42 %	65 %	78 %	100 %	
Normal Pitch Curves 一般飛行螺距曲線	P1	P2	P3	P4	P5	
	44 %	52 %	74 %	84 %	93 %	
IDLE-UP Throttle Curves 3D 飛行油门曲線	P1	P2	P3	P4	P5	
	90 %	90 %	90 %	90 %	90 %	
IDLE-UP Pitch Curves 3D 飛行螺距曲線	P1	P2	P3	P4	P5	
	0 %	25 %	50 %	75 %	100 %	



These are the standard channel mapping when satellite receivers are used.

(1) THR (2) AIL (3) ELE (4) RUD (5) GAIN (6) PIT

使用衛星天線時，內部通道已指定為：(1) THR (2) AIL (3) ELE (4) RUD (5) GAIN (6) PIT

## FEATURES 產品特色

- 3Axis** 3-axis gyroscopic flybarless system to simulate the stability of mechanical flybar system, yet at the same time achieving agile 3D performance.  
3軸陀螺儀無平衡翼系統，可模擬有平衡翼系統的穩定性，更有靈活3D性能。
- MEMS** Utilizes MEMS gyro sensors, which feature small footprint, high reliability, and excellent stability.  
採用MEMS (Micro Electro Mechanical Systems) 微型電機系統技術感測器，具有體積小、可靠性高、穩定性佳的優點。
- 12bit** Sensor with 12 bit ultra high resolution, resulting in highly precise controls.  
感測器12位元，超高分辨率，控制絕無誤差。
- 5-ABS** Supports Futaba S-FHSS 2.4Ghz transmission protocol.  
支援Futaba S-FHSS 2.4GHz 傳輸系統。
- Easy** Simplistic setup process without the need of external devices. Setup is done through 6 steps and 2 sensitivity adjustments.  
設定簡單不需額外的介面，只需六個步驟，兩個感度調整即可完成所有設定。
- Energy** Flybarless system dramatically improves 3D power output and efficiency, resulting in reduced fuel or electricity consumption.  
無平衡翼系統，可大幅降低3D大動作飛行能量消耗，提供同等機更大的動力輸出且更加節省燃油或電力。
- Stable** Highly sensitive gyroscopic sensors combined with advanced control detection routine providing higher hovering and aerobatic stability than other flybarless system.  
高感度陀螺感測器及先進偵測設計，可提供比一般平衡翼系統更佳的靜態及動態穩定性。
- 5-REV (28-90)** Designed specifically for T-REX 250 and 450, contains optimal flight parameters, no adjustments is needed out of the box to achieve superior flight performance.  
針對T-REX 250、T-REX 450設計，內建最佳飛行參數，不需調整即有優異性能表現。
- 5V (3.3-5.0V)** Capable to operate between 3.5V to 5.4V, compatible with high voltage servos.  
適用電壓3.5V-5.4V，支援高電壓伺服器。
- Small** Small footprint, light weight, minimalist and reliable design.  
體積小、重量輕，構造簡單可靠，提供操控者高性能的飛行樂趣。
- RoHS** RoHS certified.  
符合RoHS限用規章。

## 3GX FLYBARLESS SETUP INDICATORS 功能設定指示燈說明

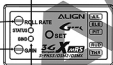

## FLYBARLESS SYSTEM SETUP MODE 無平衡翼系統設定模式

- |  |                   |
|--|-------------------|
| Flash 1 time: Aileron neutral point              | 閃爍頻率一次：副翼伺服器中立點設定 |
| Flash 2 times: Elevator neutral point            | 閃爍頻率二次：升降伺服器中立點設定 |
| Flash 3 times: Pitch neutral point               | 閃爍頻率三次：俯仰伺服器中立點設定 |
| Flash 4 times: Rudder neutral point              | 閃爍頻率四次：尾舵陀螺儀校正內設  |
| Flash 5 times: Rudder left travel limit setting  | 閃爍頻率五次：尾舵左舵行程設定   |
| Flash 6 times: Rudder right travel limit setting | 閃爍頻率六次：尾舵右舵行程設定   |

## BIND LED 對頻燈號

- |  |            |
|--|------------|
| STEADY LIT GREEN LED: Radio binding successfully | 綠燈恆亮：對頻成功  |
| FLASHING GREEN LED: Radio binding failed         | 綠燈閃爍：對頻失敗  |
| STEADY LIT RED LED: No signal detected           | 紅燈恆亮：無發射訊號 |

## ROLL RATE ADJUSTMENT DIAL 滾轉速率調整鈕



Roll rate dial is used to adjust the roll rate of helicopter's elevator and aileron; turning clockwise will increase roll rate, with faster elevator and aileron response; turning counter-clockwise will decrease roll rate, with slower elevator and aileron response. We recommend novice pilots to fly with lower roll rate.

滾轉速率控制鈕為調整直升機升降、副翼滾轉速率，往順時針調大滾轉速率，升降與副翼反應會變快，往逆時針調低滾轉速率，升降與副翼反應會變慢，初入門者建議調低滾轉速率低飛。

## GAIN ADJUSTMENT DIAL 感度調整旋鈕



Should there be any oscillation on aileron or elevator during flight, reduce the gain by turning the dial counter-clockwise approximately 10 degrees at a time. Should there be any drift front/rear/left/right during flight, increase the gain by turning the dial clockwise approximately 10 degrees at a time.

飛行時若機體有左右或前後抖動，表示感度偏高，請逆時針調整感度旋鈕，以每次調整約10度方式，調整至適當位置。飛行時若機體有左右或前後偏移時，表示感度偏低，請順時針調整感度旋鈕，以每次10度方式調整至適當位置。

## SETUP PRE-CHECK 設定前注意事項

1. During pre-flight check, please ensure 3GX MRS is securely mounted, and there are sufficient battery in the transmitter.
2. There is only one way to mount 3GX MRS on the helicopter. Do not alter the mounting direction, otherwise incorrect compensation may result in danger of crashing.
3. After 3GX MRS has bounded with transmitter, please ensure 3GX MRS power indicator is lit correctly, and that swashplate and rudder is compensating the correct direction.
4. To ensure proper initialization of 3GX MRS, please keep the helicopter stationary during power up, do not move any transmitter sticks.
5. 3GX MRS supports transmitters compatible with 2.4Ghz S-FHSS transmission type. Please ensure the swashplate setting in transmitter is set to H-1 prior to making any setting changes.
6. While setting neutral position of servos, all steps must be completed before power is turned off, otherwise servos neutral setting will fail. To ensure optimal flight performance, please ensure swashplate is level during swashplate neutral setting.
7. Adjustment of elevator and aileron roll rate must be done with the dials on 3GX MRS, do not adjust elevator and aileron travel end points on transmitter. On the other hand, rudder speed is adjusted through rudder end points.
8. To achieve optimal flight performance, pitch(CH6) and rudder (CH4) travel can be adjusted on the transmitter, but do not adjust elevator and aileron end points on transmitter.
9. Elevator and Aileron gyro gain must be adjusted through the dials on 3GX MRS unit. Rudder gyro gain is adjusted through transmitter's GYRO SENS function.
10. To ensure optimal signal reception, 3GX MRS antennas should be at least 1/2 inch away from conductive material, and should not be bent excessively. Try to keep the transmitter close to 3GX MRS during binding. Should it unintentionally bind to another transmitter, just perform binding process again.

1. 在每次飛行之前，請確認3GX MRS是否固定良好，並且檢查發射器電力是否足夠。
2. 3GX MRS安裝在直昇機上的方式只有一種，請勿任意更改安裝方向，以免修正錯誤造成危險。
3. 發射器與3GX MRS完成對接後，請確認3GX MRS的電源燈以及十字盤和舵舵的修正是否正確。
4. 開機時請保持直昇機靜止，且不要動發射器任何桿，以免3GX MRS初始化錯誤。
5. 3GX MRS支援的發射器類型為2.4GHz S-FHSS，在進入所有設定之前，請確認發射器的十字盤類型須為H-1模式。
6. 在設定伺服機中立點位置時，必須把全部步驟完成才可將電源關閉，否則設定資料不感記憶。設定完後在中立點位置時請將十字盤調成水平以獲得最佳飛行性能。
7. 調整升降及副翼的滾轉速率時只能用3GX MRS上的旋鈕來調整，不可利用發射器上的升降和副翼行程選項來調整，調整舵舵速率時必須利用發射器上的舵舵行程來調整。
8. 為獲得最佳飛行性能，可以調整發射器上的轉距(CH6)以及舵舵(CH4)的行程，但不可調整發射器上的升降和副翼行程。
9. 升降及副翼的陀螺感度必須用3GX MRS上的旋鈕調整，舵舵的陀螺感度請利用發射器的GYRO SENS選項來調整。
10. 3GX MRS的天線位置應遠離導電材料至少半英吋的距離，且不要過度彎曲，以獲得最佳的對接效果。發射器與3GX MRS對接時，請儘量靠近，若對到別架發射器時，重新對接即可。

## INSTALLATION 3GX MRS 接線方式



Please ensure the swashplate setting in transmitter is set to H-1 prior to making any setting changes.  
請確認發射器的十字盤類型須為H-1模式。

1. Servo can only be installed in this orientation when 3GX MRS is used: with head point forward, right forward is aileron (CH1), left forward is pitch (CH6), mid-rear is elevator (CH2). CH1 and CH6 cannot be interchanged, otherwise helicopter will not function correctly.
2. Swashplate type setting on the transmitter should be set to H1 traditional swashplate type.
3. If swashplate movement is incorrect after assembly per instruction, please double check to see if 3GX MRS model setting is set to T-REX 450 Sport/PLUS DFC. (See page 17)
4. To avoid damages to system, digital servo must be used for swashplate. Recommend servo specification: speed of 0.09s/60 degrees or faster; torque 2.2kg or higher.

1. 使用3GX MRS 伺服器的安裝方式只有一種。當機頭朝前時，右前為副翼(CH1)；左前為螺距(CH6)；中後為升降(CH2)。CH1、CH6不可換。如果沒依照圖示連結，直昇機動作會不正確。
2. 遙控器十字盤類型，必須選擇H1十字盤類型。
3. 依照圖式安裝完畢，如果十字盤動作不正確，請檢查3GX MRS機型設定是否為T-REX450 SPORT/PLUS DFC(機型檢查與設定參閱第17頁)。
4. 十字盤必須安裝垂直位置，否則會造成損壞。  
建議規格：速度0.09秒/60度以內；扭力2.2kg以上。

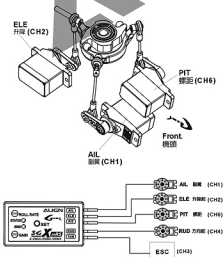

## MODEL SELECTION 機型選擇

3GX MRS is a flybarless stabilization system designed specifically for Align's smaller helicopters, with integrated basic setup parameters for T-REX250, T-REX 450 SPORT/PLUS DFC, T-REX450 PRO and T-REX 500. The 3GX MRS unit bundled with T-REX 450 PLUS DFC comes already configured for the specific helicopter. If you wish to use the 3GX MRS system in the two other helicopters, follow the steps below to reconfigure the helicopter type.

3GX MRS 是特別針對空拍小模型直昇機設計的無平衡架系統，內建 T-REX250、T-REX 450 SPORT/PLUS DFC、T-REX450 PRO、T-REX 500 三種機型的的基本參數設定，並為此三種機型專用的無平衡架系統。T-REX 450 PLUS DFC 出廠時 3GX MRS 已預設該機型的參數設定，如果您要將 3GX MRS 應用到其餘兩種機型時，可以參照下列方式來做機型更改。

### STEP1.MODEL DISPLAY 步驟1.機型顯示

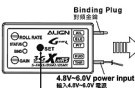

4.8V-6.0V power input  
輸入4.8V-6.0V 電源

Hold The Set Button.  
按住SET鍵不放

Insert binding plug into AIL port, press and hold SET, then insert 4.8-6V power into RUD of THR port.  
對稱金線插入 AIL 端，接著 SET 鍵不放，接著從 RUD 或 THR 端插入 4.8V-6.0V 電源。



1. Red LED lit  
亮紅燈

Release SET button  
放開SET鍵

When STATUS LED is lit steady red, release SET button and 3GX MRS will display current model.  
當 STATUS LED 呈現紅燈亮後，放開 SET 鍵上 3GX MRS 就會開始顯示目前機型。

2. Release SET button  
放開SET鍵

When STATUS LED is lit steady red, release SET button and 3GX MRS will display current model.  
當 STATUS LED 呈現紅燈亮後，放開 SET 鍵上 3GX MRS 就會開始顯示目前機型。

Status LED indicator for the existing model.  
STATUS 燈顯示目前的機型



STATUS LED flashes RED once, 250PRO DFC  
STATUS LED flashes RED twice, 450SPORT/PLUS  
STATUS LED flashes RED thrice, 450PRO  
STATUS LED flashes RED four, 500PRO  
STATUS 紅燈閃爍頻率1次，250 PRO DFC  
STATUS 紅燈閃爍頻率2次，450 SPORT / PLUS  
STATUS 紅燈閃爍頻率3次，450 PRO  
STATUS 紅燈閃爍頻率4次，500 PRO

### STEP2.MODEL SELECTION 步驟2.選擇機型

Choose hell model and hold the set button  
選擇機型後，按SET鍵不放



T-REX 450 PLUS DFC

Pull out the binding plug, connect to the channel corresponding to the model.  
將對稱金線拔下，接到對應機型的頻道。

AIL: T-REX 250  
RUD: T-REX 450SPORT / PLUS DFC  
PIT: T-REX 450PRO  
RUD: T-REX 500PRO  
將對稱金線拔下，接到對應機型的頻道上。  
AIL: T-REX 250  
ELE: T-REX 450SPORT / PLUS DFC  
PIT: T-REX 450PRO  
RUD: T-REX 500PRO

1. Flash alternately in red and green, model changing  
紅、綠交錯閃爍，顯示機型中



2. Release The Set Button  
放開SET鍵

When STATUS and BIND LED's flash alternately in red and green, release the SET button.  
選擇好機型後按 SET 鍵不放，當 STATUS 與 BIND 紅、綠交錯閃爍，表示更改機型設定完成，設定完成後就可放開 SET 鍵。

Status LED indicator for the existing model.  
STATUS 燈顯示目前的機型



STATUS LED flashes RED once, 250PRO DFC  
STATUS LED flashes RED twice, 450SPORT/PLUS  
STATUS LED flashes RED thrice, 450PRO  
STATUS LED flashes RED four, 500PRO  
STATUS 紅燈閃爍頻率1次，250 PRO DFC  
STATUS 紅燈閃爍頻率2次，450 SPORT / PLUS  
STATUS 紅燈閃爍頻率3次，450 PRO  
STATUS 紅燈閃爍頻率4次，500 PRO

STATUS LED will flash to indicate the selected model type. Pull out power and binding plugs to complete setting.  
此 STATUS 燈就會呈現所選機型的燈亮，最後拔掉電源與對稱金線就完成設定。

## TRANSMITTER BINDING 遙控器對稱

The radio in every 3GX MRS equipped Align RTF helicopter kits has already been bonded to the 3GX MRS, so it is worthless out of the box after battery is connected. If you wish to use other S-FHSS 2.4GHz system, following procedure can be used to bind the radio to 3GX MRS system.

亞拓每架搭配 3GX MRS 的 RTF 版本直昇機，出廠前遙控器與 3GX MRS 都已完成對稱，插上電池後請重啟 3GX MRS 狀態燈與對稱燈都為綠燈恆亮，才可以進行飛行。如果您想使用其他 S-FHSS 2.4GHz 系統遙控器的需求，您可以使用以下方式與 3GX MRS 對稱。

STEADY LIT GREEN LED: Radio binding successfully  
FLASHING GREEN LED: Radio binding failed  
STEADY LIT RED LED: No signal detected

綠燈恆亮：對稱成功  
綠燈閃爍：對稱失敗  
紅燈恆亮：無發射訊號



POWER ON

### STEP1. 步驟1.

Turn on transmitter, connect 3GX MRS to power source. If signal is detected, BIND LED will flash green, otherwise it will flash red. If transmitter is turned on, but BIND is still steady red, then power cycle 3GX MRS so it will restart transmitter signal search.

打開遙控器，將 3GX MRS 插上電源後，若偵測到遙控器訊號，燈未成功對稱 BIND 燈會綠燈閃爍。若已開等發射器，但 BIND 燈為紅燈恆亮，請將 3GX MRS 重新給電。重新再試遙控器訊號。



If the LED status appears steady lit green, it mean the binding is successfully. Please skip Step 2.

If the LED status appears flashing green or steady lit red, it means the binding is failed. Please proceed Step 2 for rebinding.

若燈亮為綠燈恆亮，代表對稱成功，不須進行步驟 2 重新對稱。  
若燈亮為綠燈閃爍或紅燈恆亮，代表對稱失敗，則進行步驟 2 重新對稱。

**1. Press and hold SET button**

長按 SET 鍵不放

**2. LED status changes from flashing red into constant green.**  
燈光由紅燈閃爍為綠燈恆亮**STEP2. 步驟 2.****Press and hold SET button, at this time BIND LED will be flashing red, hold the SET button until BIND LED shows steady green, then release SET button to complete binding.**

按著 SET 鍵不放，此時 BIND 燈號會紅燈閃爍，直到 BIND 燈號顯示綠燈恆亮後，放開 SET 鍵即完成對頻。

**USING DSM2 SATELLITE RECEIVERS 使用 DSM2 衛星天線****PROVIDE 4.8V-6.0V POWER INPUT**

輸入 4.8V-6.0V 電源輸入

Remote receiver  
衛星天線  
Blinking red LED  
紅燈閃爍Binding Plug  
對頻金插**STEP1. 步驟 1.**

1. Plug the satellite receiver into ANT port, and the binding plug on THR channel.
2. After feeding 5-6V power through RUD or any other channels, BIND LED will turn steady red, while satellite LED flashes red.

1. 將衛星天線接到 ANT 插槽，並且把對頻線插在 THR 通道。
2. 由 RUD 或其於通道供給 5-6V 電源後，此時 BIND 燈為紅燈恆亮，衛星天線為紅燈閃爍。

Press and hold BIND button while powering up.  
按著 BIND 鍵同時Remote receiver  
衛星天線  
Steady red LED indicates successful binding.  
紅燈恆亮表示對頻完成**STEP2. 步驟 2.**

1. Press and hold the BIND button on Spektrum/JR transmitter, power on the transmitter, wait for transmitter to display "Binding," then release BIND button.
2. When satellite receiver LED shows steady it RED, remove the binding plug from THR channel.
3. When STATUS and BIND LEDs turn into steady green, this indicates binding complete and 3GX MRS initialized

1. 先將衛星天線接到 ANT 插槽，並且把對頻線插在 THR 通道。
2. 等到衛星天線為紅燈恆亮後，將插在 THR 通道的對頻線移除。
3. 等到 STATUS 和 BIND 燈為綠燈恆亮時，表示對頻以完成且 3GX MRS 調機成功，可正常執行功能。

**USING DSMX SATELLITE RECEIVERS 使用 DSMX 衛星天線****PROVIDE 4.8V-6.0V POWER INPUT**

輸入 4.8V-6.0V 電源輸入

Remote receiver  
衛星天線  
Blinking red LED  
紅燈閃爍Binding Plug  
對頻金插Press and hold BIND button while powering up.  
長按 SET 鍵不放，然後輸入電源**STEP1. 步驟 1.**

1. Plug the satellite receiver into ANT port, and the binding plug on THR channel.
2. Press and hold the SET button on 3GX MRS, and feed 5-6V power through RUD or any other channels, BIND LED will turn steady red, while satellite LED flashes red.

1. 先將衛星天線接到 ANT 插槽，並且把對頻線插在 THR 通道。
2. 按著 3GX MRS 的 SET 鍵後，再由 RUD 或其於通道供給 5-6V 電源，此時 BIND 燈為紅燈恆亮，衛星天線為紅燈閃爍。

Press and hold BIND button while powering up.  
按著 BIND 鍵同時Remote receiver  
衛星天線  
Steady red LED indicates successful binding.  
紅燈恆亮表示對頻完成**STEP2. 步驟 2.**

1. Press and hold the BIND button on Spektrum transmitter, power on the transmitter, wait for transmitter to display "Binding," then release BIND button.
2. When satellite receiver LED shows steady it RED, remove the binding plug from THR channel.
3. When STATUS and BIND LEDs turn into steady green, this indicates binding complete and 3GX MRS initialized successfully. The system is ready for use.

1. 長按 SPEKTRUM/JR 發射器的 BIND 按鈕後，打開發射器電源，直到發射器螢幕上顯示 Binding 字樣，在放開 BIND。
2. 等到衛星天線為紅燈恆亮後，將插在 THR 通道的對頻線移除。
3. 等到 STATUS 和 BIND 燈為綠燈恆亮時，表示對頻以完成且 3GX MRS 調機成功，可正常執行功能。



- If both Spektrum and Futaba transmitters are powered up (both have previously bound to MRS), and a satellite receiver is connected to 3GX MRS, the 3GX MRS will select Spektrum system after power up. If no satellite receivers are connected, 3GX MRS will select Futaba system.
- If a satellite receiver is connected to 3GX MRS, and only Futaba transmitter is powered up, 3GX MRS will select Futaba system after power up. If Spektrum transmitter is powered up afterwards, 3GX MRS will not switch over to Spektrum system.
- On the other hand, if Spektrum transmitter is powered up and 3GX MRS has already selected Spektrum system, subsequent power up of Futaba transmitter will not cause 3GX MRS to switch over to Futaba system.
  - 如果 Spektrum 發射器和 Futaba 發射器都在預設狀態(先前都已綁定 MRS 到機上)，且 3GX MRS 有連接衛星接收器，若此時將 3GX MRS 開機，3GX MRS 會選擇 Spektrum 系統。如果沒有衛星接收器，3GX MRS 會選擇 Futaba 系統。
  - 如果 3GX MRS 有連接衛星接收器，且只有 Futaba 發射器先開機，若此時將 3GX MRS 開機，3GX MRS 會選擇 Futaba 系統。即便後來再將 Spektrum 發射器開機，3GX MRS 也不會轉到 Spektrum 系統上。
  - 反之，若 Spektrum 發射器先開機，3GX MRS 選擇 Spektrum 系統後，即便再將 Futaba 發射器開機，3GX MRS 也不會轉到 Futaba 系統上。

### FAILSAFE(LAST POSITION HOLD) 失控保護(保留最後指令)

When helicopter lost connectivity with your radio under this setting, all channels will hold at the last command position, except throttle channel which goes to a preset position.

- Push throttle stick to the desired fail safe position.
- Please refer to P.19 & P.20 binding method, and perform radio binding steps.
- After successful binding, do not power off the 3GX MRS, unplug the binding plug and allow 3GX MRS to enter initializing process. The last position hold function will be active after the 3GX MRS initializes.
- Test Method: Power off transmitter. The throttle channel should move to preset position, while all other channels should hold in their last position.

在此模式下，若您的遙控機與接收器失連，除油门頻道為預設位置，其餘頻道皆為最後指令位置。

- 將油门推桿推至您所需要的鎖死安全位置。
- 請參閱 P.19 及 P.20 的綁機方式，執行與接收器的綁機動作。
- 綁機成功後，不要關閉 3GX MRS 電源，先將對機線插拔線，3GX MRS 會進入開機狀態，待 3GX MRS 開機完成後，即可保留最後指令設定。

測試方法：將遙控器關機，除了油门頻道為預設安全位置外，其餘頻道皆為失連前的最後指令位置。

### FAILSAFE(PRE-SET POSITION HOLD) 失控保護(回復預設值)

When helicopter lost connectivity with your radio under this setting, all channels will move to the pre-set position.

- Please refer to P.19 & P.20 binding method, and power up the 3GX MRS. After the rapid flash of satellite's LEDs, Pull the binding plug off.
- Power up radio transmitter, and perform radio binding steps. After radio is bound, LED on the satellite antennas will end the rapid flash, following by slower flash.
- Move the transmitter sticks to the desired failsafe position while the LED is flashing in slower mode.
- Satellite antenna's LED will lit up after 5 seconds, and 3GX MRS goes through initializing process. The failsafe position will be set after the 3GX MRS initializes.

在此模式下，若您的遙控機與接收器失連，除油门頻道為預設位置，其餘頻道皆為最後指令位置。

- 請參閱 P.19 及 P.20 的綁機方式，先開機 3GX MRS 電源，待衛星天線上 LED 快速閃爍後，將對機線插拔線，將對機線插拔線，3GX MRS 會進入開機狀態，LED 會由快速閃爍變為慢速閃爍，之後再將舵桿推至您所需要的預設安全位置。
- 在接收器開機狀態時，將接收器上的所有舵桿推至您所預設的安全位置。
- 5秒後衛星天線 LED 會為常亮，3GX MRS 進入開機狀態，待 3GX MRS 開機完成後，即可回復預設值。
- 測試方法：將遙控器關機，所有頻道為預設安全位置。

## 3GX MRS SETTINGS 3GX MRS 設定



In order for the settings to stick, all 6 setting parameters for 3GX MRS must be completed followed with a press of SET button, regardless if any changes are made for each settings. 3GX MRS 的六項設定，不論有無變動，皆須逐一完成，並按下 SET 鍵退出設定，否則 3GX MRS 將不會記憶設定。



Status LED steady lit  
狀態燈常亮

Swashplate jumps  
up/down 3 times  
十字盤跳三下

Binding green LED steady lit  
對機綠燈常亮

### 3GX MRS INITIALIZATION 3GX MRS 開機

Connect power, if transmitter binding is successful, BIND LED will light solid green; otherwise it will flash green. At this time, STATUS LED lights green indicates successful power up, steady green means rudder is in heading lock mode; steady red means rudder is in non-heading lock mode. Swashplate will jump up and down 3 times after power up.

接上電源，若和遙控器對機成功後，BIND 燈為綠燈常亮，否則綠燈閃爍。此時 STATUS 燈常亮即代表開機成功，綠燈常亮，代表尾舵為鎖定。紅燈常亮，代表尾舵為非鎖定。開機完成時，十字盤會跳三下。

Power up transmitter, connect power to 3GX MRS. When STATUS and BIND LEDs are light steady green, SET button is used to enter setup mode.

先打開遙控器，將 3GX MRS 接上電源後，當 STATUS 和 BIND 燈亮為綠燈常亮時，表示開機完成，此時按 SET 鍵一次即可進入設定。

Press SET button to enter Setup  
按 SET 鍵進入設定



- Flash 1 times: Aileron neutral point
- Flash 2 times: Elevator neutral point
- Flash 3 times: Pitch neutral point
- Flash 4 times: Rudder neutral point
- Flash 5 times: Rudder left travel limit setting
- Flash 6 times: Rudder right travel limit setting

- 閃爍頻率一次：副翼舵線器中立點設定
- 閃爍頻率二次：升降舵線器中立點設定
- 閃爍頻率三次：俯仰舵線器中立點設定
- 閃爍頻率四次：尾舵舵線器正反角設定
- 閃爍頻率五次：尾舵左舵行程設定
- 閃爍頻率六次：尾舵右舵行程設定

### ENTERING 3GX MRS SETUP 進入 3GX MRS 設定

After system initializes, press SET button once to enter 3GX MRS setup mode. While in setup mode, STATUS LED will flash a number of times indicating the current setting selection. Press SET button to skip to next setting selection. 3GX MRS must complete all 6 setting selections before the settings are memorized.

開機完成後，按 SET 鍵一次就會進入 3GX MRS 設定。進入設定後，STATUS 燈會以閃爍次數代表所進入的設定選項。按設定 SET 鍵就會跳往下一個設定選項。3GX MRS 必須完成 6 項設定才會記憶設定內容。



1. Disconnect motor to ESC to prevent accidental start-up during setup.
2. The throttle stick must remain in center position during setup (or Switch HOLD), pitch curve must be at 50% position and remain fixed.

1. 設定前先拆除馬達線，避免設定中使馬達運轉造成危險。
2. 設定時油門搖桿置於中間，螺距曲線 50% 輸出的位置（或切入 HOLD 模式），不可再移動。

Throttle stick fixed position

油門搖桿固定

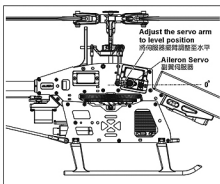

Adjust the servo arm to level position  
將副翼伺服器調整至水平

Aileron Servo  
副翼伺服器

### 1. AILERON SERVO NEUTRAL POINT SETTING

副翼伺服器中立點設定

Momentarily press SET button first time, if STATUS LED flashes once continuously and BIND LED is off, this indicates you are in neutral setting mode of servo 1. At this time you can use RUD on transmitter to trim the neutral position of servo 1. After completing this setting it will proceed into next step.

進入 3GX MRS 設定的第一個設定為副翼伺服器中立點設定，STATUS 燈為持續閃爍一次且 BIND 燈亮為熄滅，此時可用遙控器舵桿搖桿調整副翼伺服器中立點位置，完成後進入下一個步驟。

Move rudder stick to adjust

滾動舵桿調整



Flash green once

閃爍綠燈一次

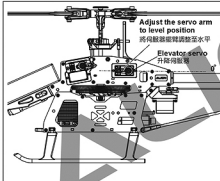

Adjust the servo arm to level position  
將升降伺服器調整至水平

Elevator Servo  
升降伺服器

### 2. ELEVATOR SERVO NEUTRAL POINT SETTING

升降伺服器中立點設定

Momentarily press SET button second time, if STATUS LED flashes twice continuously and BIND LED is off, this indicates you are in neutral setting mode of servo 2. At this time you can use RUD on transmitter to trim the neutral position of servo 2. After completing this setting it will proceed into next step.

接著按 SET 鍵一次進入升降伺服器中立點設定，STATUS 燈亮為持續閃爍綠燈二次且 BIND 燈亮為熄滅，此時可用遙控器舵桿搖桿調整升降伺服器中立點位置，設定完成後進入下一個步驟。

Move rudder stick to adjust

滾動舵桿調整



Flash green twice

閃爍綠燈二次

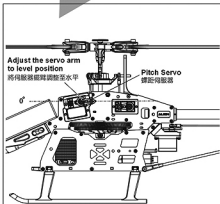

Adjust the servo arm to level position  
將螺距伺服器調整至水平

Pitch Servo  
螺距伺服器

### 3. PITCH SERVO NEUTRAL POINT SETTING

螺距伺服器中立點設定

Momentarily press SET button third time, if STATUS LED flashes three times continuously and BIND LED is off, this indicates you are in neutral setting mode of servo 3. At this time you can use RUD on transmitter to trim the neutral position of servo 3. After completing this setting it will proceed into next step.

接著按 SET 鍵一次進入螺距伺服器中立點設定，STATUS 燈亮為持續閃爍綠燈三次且 BIND 燈亮為熄滅，此時可用遙控器舵桿搖桿調整螺距伺服器中立點位置，設定完成後進入下一個步驟。

Adjust aileron, elevator, and pitch servos' neutral point so that servo arms and swashplate remain horizontal (with throttle stick at 50% position). How level your swashplate will directly affect how well the flight characteristic of 3GX MRS is.

調整副翼、升降、螺距伺服器中立點，使伺服器總臂與十字盤皆保持水平位置（此時油門搖桿置於 50% 位置），十字盤的水平與否將會直接影響 3GX MRS 的飛行表現與穩定性。

Move rudder stick to adjust

滾動舵桿調整



Flash green thrice

閃爍綠燈三次



#### 4. RUDDER GYRO DIRECTION SETTING

尾舵陀螺修正方向設定

Momentarily press SET button fourth time, if STATUS LED flashes four times continuously and BIND LED is steady lit green, this indicates you are in rudder compensation direction setting mode. If compensation direction is correct, then skip this step. If compensation direction is reversed, use RUD on transmitter to reverse the direction, and BIND LED will change to steady lit red. After completing this setting it will proceed into next step.

接著按SET鍵一次進入尾舵陀螺修正方向設定，STATUS燈號為持續閃爍綠燈四次且BIND燈號為綠燈常亮，修正方向錯誤，利用遙控器尾舵桿改變尾舵修正方向，此時BIND燈號變為紅燈常亮，設定完成後進入下個步驟。

Flash green 4 times

閃爍綠燈四次



Green LED: normal direction  
Red LED: reverse direction  
400DFC is green light  
綠燈：正常 紅燈：反向  
450 PLUS DFC 為綠燈

Move rudder stick to adjust

撥動尾舵調整



Tail moving direction

搖動尾舵方向

Trim direction for tail servo horn.

尾舵舵臂修正方向

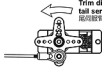

CAUTION

注意

To check the head lock direction of gyro is to move the tail counter-clockwise and the tail servo horn will be trimmed counter-clockwise. If it trims in the reverse direction, please switch the gyro to "REVERSE".

尾舵陀螺修正方向確認：當平搖器旋轉尾舵時尾舵舵臂旋轉，尾舵舵臂修正方向時修正，修正錯誤時，撥動尾舵桿改變尾舵陀螺修正方向。

#### 5. RUDDER LEFT TRAVEL LIMIT SETTING

尾舵左舵行程設定

Momentarily press SET button fifth time, if STATUS LED flashes five times continuously and BIND LED is off, this indicates you are in left rudder end point adjustment mode. At this time rudder will drift to one side. Use RUD on transmitter to set the maximum end point on left side. After completing this setting it will proceed into next step.

接著按SET鍵一次進入尾舵左舵行程設定，STATUS燈號為持續閃爍綠燈五次且BIND燈號為熄滅，此時尾舵會偏向單邊，利用遙控器尾舵桿設定尾舵向左最大的行程，設定完成後進入下個步驟。

Flash green 5 times

閃爍綠燈五次



Move rudder stick to adjust

撥動尾舵調整



CAUTION

注意

Adjust the rudder travel limit to the maximum without mechanical binding will result in better rudder gyro compensation effect.

左機槳不平滑的情形下，設定較大的尾舵行程可使尾舵陀螺修正較好。

#### 6. RUDDER RIGHT TRAVEL LIMIT SETTING

尾舵右舵行程設定

Momentarily press SET button sixth time, if STATUS LED flashes six times continuously and BIND LED is off, this indicates you are in right rudder end point adjustment mode. At this time rudder will drift to one side. Use RUD on transmitter to set the maximum end point on right side. After completing this setting it will proceed into next step.

再按SET鍵一次進入尾舵右舵行程設定，STATUS燈號為持續閃爍綠燈六次且BIND燈號為熄滅，此時尾舵會偏向單邊，利用遙控器尾舵桿設定尾舵向右最大的行程，設定完成後按SET鍵完成3GX MRS設定。

Flash green 6 times

閃爍綠燈六次



Move rudder stick to adjust

撥動尾舵調整



CAUTION

注意

Adjust the rudder travel limit to the maximum without mechanical binding will result in better rudder gyro compensation effect.

左機槳不平滑的情形下，設定較大的尾舵行程可使尾舵陀螺修正較好。

WARNING

警告

In order for the settings to stick, all 6 setting parameters for 3GX MRS must be completed followed with a press of SET button, regardless if any changes are made for each settings.

3GX MRS的六項設定，不論有無變動，皆須逐一完成，並按下SET鍵選出設定，否則3GX MRS將不會記憶設定。



## MAIN ROTOR PITCH ADJUSTMENT 主旋翼螺距調整

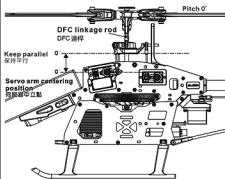

1. Press SET button to enter 3GX MRS setup mode. This setting will eliminate any swashplate interaction which may affect pitch precision.
  2. Move throttle stick to enter, pitch curve at 50% position. Pitch should be at 0 degrees during this setting.
  3. If servo arms and swashplate is already level at 0 degrees, but main rotor blades pitch is not at 0 degree, please adjust the length of DFC linkage rods to achieve 0 degrees pitch.
1. 按 SET 鍵進入 3GX MRS 設定。此將會關閉 3GX MRS 的陀螺儀，以避免對十字盤的修正而影響螺距的層面。
2. 將油门推桿置中，螺距曲線 50% 輸出位置，請調整主旋翼螺距為 0 度。
3. 如果伺服臂螺距及十字盤已經水平 0 度，但主旋翼螺距不為 0 度時，請調整 DFC 連桿長度使螺距為 0 度。



Disconnect motor from ESC prior to setup.  
設定前，請先將馬達線拔除。



Before setting up the 3GX FBLS system, please use a swashplate leveler to level out the swashplate to make sure the swashplate is leveled to ensure 3GX provides the best performance.

使用 3GX 平衡系統，請務必用十字盤調整器校正十字盤，確保十字盤達到水平狀態，這樣才能確保 3GX 飛行性能達到最佳效果。

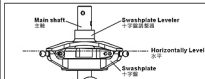

## COLLECTIVE PITCH ADJUSTMENT 集體螺距調整

The collective pitch for 3GX MRS must be adjusted in radio's EPA (End Point) function.

3GX MRS 集體螺距必須從遙控器 CH6 透過的 EPA (END POINT) 功能中調整。

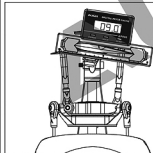

### 1. MAX. COLLECTIVE PITCH ANGLE 最大集體螺距角度

Push the throttle stick to the maximum, adjust maximum collective pitch value through radio's EPA function on CH6.

將遙控器油门選擇推至最高，使用 EPA 功能調整 CH6 透過的最大集體螺距角度。



Disconnect motor from ESC prior to setup.  
設定前，請先將馬達線拔除。

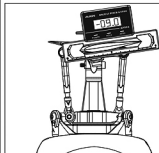

### 2. MIN. COLLECTIVE PITCH ANGLE 最小集體螺距角度

Push the throttle stick to the minimum, adjust minimum collective pitch value through radio's EPA function on CH6.





將遙控器油门選擇推至最低，使用 EPA 功能調整 CH6 透過的最小集體螺距角度。



Disconnect motor from ESC prior to setup.  
設定前，請先將馬達線拔除。



**3GX MRS INDICATOR LED 3GX MRS 指示燈說明**

STATUS  BIND	STATUS constant green STATUS 綠燈恆亮	STATUS constant red STATUS 紅燈恆亮	STATUS off STATUS 不亮
	 <p><b>BIND constant green</b> BIND 綠燈恆亮</p>	<p>Successful initialization and radio bounded, rudder in heading lock mode.</p> <p>完成對頻且開機成功，尾舵為鎖定狀態</p>	<p>Successful initialization and radio bounded, rudder in non-heading lock mode.</p> <p>完成對頻且開機成功，尾舵為非鎖定狀態</p>
 <p><b>BIND flashing green</b> BIND 綠燈閃爍</p>	<p>Revert back to original transmitter signal that was lost during usage, rudder is in head locking mode, and detected other transition signals.</p> <p>使用過程中失去原本發射器訊號，尾舵為鎖定狀態，且檢測到其它發射器訊號</p>	<p>Revert back to original transmitter signal that was lost during usage, rudder is in non-head locking mode, and detected other transition signals.</p> <p>使用過程中失去原本發射器訊號，尾舵為非鎖定狀態，且檢測到其它發射器訊號</p>	<p>3GX MRS detects radio signal, but is not bound to the radio. 3GX MRS 偵測到發射器訊號，但未完成對頻</p>
 <p><b>BIND constant red</b> BIND 紅燈恆亮</p>	<p>Successful initialization but radio binding failed, rudder in heading lock mode.</p> <p>3GX MRS 對頻失敗，但開機成功，尾舵為鎖定</p>	<p>Successful initialization but radio binding failed, rudder in non-heading lock mode.</p> <p>3GX MRS 對頻失敗，但開機成功，尾舵為非鎖定</p>	<p>No signal detected from radio, please check if transmitter is powered on.</p> <p>3GX MRS 未偵測到發射器訊號，請確認發射器是否開啟</p>
 <p><b>BIND flashing red</b> BIND 紅燈閃爍</p>	<p>—</p>	<p>—</p>	<p>Signal detected from radio, and set button was pressed for binding.</p> <p>3GX MRS 偵測到發射器訊號，且使用者正按SET鍵對頻中</p>
 <p><b>BIND off</b> BIND 不亮</p>	<p>—</p>	<p>—</p>	<p>No power connecting to 3GX MRS 3GX MRS 未連接電源</p>

**SPECIFICATIONS 產品規格**

1. Operating voltage range : DC 3.5 ~ 8.4V
2. Operating current consumption : <100mA @ 4.8V
3. Rotational detection rate :  $\pm 300^\circ/\text{sec}$
4. Rudder yaw detection rate :  $\pm 600^\circ/\text{sec}$
5. Sensor resolution : 12 bit
6. Operating temperature :  $-20^\circ\text{C} \sim 65^\circ\text{C}$
7. Operating humidity : 0% ~ 95%
8. Swashplate support : Mode H-1
9. Receiver support : 2.4 GHz S-FHSS - DSM2 / DSMX

1. 操作電壓範圍：DC 3.5 ~ 8.4V
2. 工作電流：<100mA @ 4.8V
3. 側滾及俯仰角速度範圍： $\pm 300^\circ/\text{sec}$
4. 尾舵角速度範圍： $\pm 600^\circ/\text{sec}$
5. 感測器解析度：12 bit
6. 操作溫度： $-20^\circ\text{C} \sim 65^\circ\text{C}$
7. 操作濕度：0% ~ 95%
8. 支援十字鐘型：Mode H-1
9. 支援發射機類型：2.4 GHz S-FHSS - DSM2 / DSMX

If you are using ALIGN T6 transmitter, please refer the following chart to setup the transmitter. For advanced 3D flight, please refer page 44 of ALIGN T6 RADIO CONTROL SYSTEM instruction manual.

如果您是使用 ALIGN T6 遙控器，您可以參考下表來設定遙控器。要進一步進行 3D 飛行，可以參閱 T6 遙控器說明書第 44 頁，開啟特技飛行模式。

MENU FUNCTION 功能設置		1CH	2CH	3CH	4CH	5CH	6CH	SW
REVR	Servo Reverse 伺服器正反轉	<b>[N]</b> • R	<b>[N]</b> • R	N • <b>[R]</b>	<b>[N]</b> • R	<b>[N]</b> • R	<b>[N]</b> • R	
DIR	Dual Rate setting 雙速率設定	▲ 100 %	▲ 100 %		▲ 100 %			A • <b>[B]</b> • I-DL
		▼ 100 %	▼ 100 %		▼ 100 %			
EXPO	Exponential setting 動作曲線設定	▲ -30 %	▲ -30 %		▲ -15 %			
		▼ 0 %	▼ 0 %		▼ 0 %			
EPA	End Point Adjust 伺服器行程量調整	▲ 100 %	▲ 100 %	▲ 100 %	▲ 100 %	▲ 100 %	▲ 60 %	
		▼ 100 %	▼ 100 %	▼ 100 %	▼ 100 %	▼ 100 %	▼ 60 %	
TRIM	Trims 外置調	%	%	%	%			
STRM	Sub Trim 內置調	%	%	%	%			
F/S	Failsafe 失控保護	<b>[NOR]</b> • F/S	<b>[NOR]</b> • F/S	NOR • <b>[F/S]</b>	<b>[NOR]</b> • F/S	<b>[NOR]</b> • F/S	<b>[NOR]</b> • F/S	
		%	%	15 %	%	%	%	

MIXING SETTING 混控設定								
N-TH	Normal Throttle Curves 一般飛行模式油門曲線		P1	P2	P3	P4	P5	
			0 %	44 %	65 %	85 %	100 %	
N-PI	Normal Pitch Curves 一般飛行模式螺距曲線		P1	P2	P3	P4	P5	
			44 %	52 %	74 %	84 %	93 %	
I-TH	Idle-up Throttle Curves 特技飛行模式油門曲線	<b>[INH]</b> • <b>[ON]</b>	P1	P2	P3	P4	P5	
			90 %	90 %	90 %	90 %	90 %	
I-PI	Idle-up Pitch Curves 特技飛行模式螺距曲線		P1	P2	P3	P4	P5	Sw:
			0 %	25 %	50 %	75 %	100 %	<b>[C]</b> • A • B
HOLD	Throttle Hold 油門鎖定	<b>[INH]</b> • <b>[ON]</b>	Throttle hold position 0 %					
			P1	P2	P3	P4	P5	
H-PI	Hold Pitch Curves 油門鎖定螺距曲線		0 %	25 %	50 %	75 %	100 %	
REVO	Pitch-Rudder Mixing 螺距-偏航混控	<b>[INH]</b> • <b>[ON]</b>	▼ %	▲ %				
GYRO	Gyro Mixing 陀螺儀感應	<b>[INH]</b> • <b>[ON]</b>	▼ 40 %	▲ 45 %			A • B • <b>[I-DL]</b>	
SW-T	Swash-Throttle Mixing 十字槳-油門控制	<b>[INH]</b> • <b>[ON]</b>	AIL	ELE	RUD			
RING	Swash Ring 十字槳環圈	<b>[INH]</b> • <b>[ON]</b>	%					
SWSH	Swash Types 十字槳類型	Mode	Mode	AIL	ELE	PIT		
		<b>[H-1]</b>	HR-3 • H-3 • HE3	%	%	%		
DELY	Throttle Pitch Delay 油門延遲	<b>[INH]</b> • <b>[ON]</b>	CH3	CH6				
			%	%				
HOVP	Hovering Pitch 停機調整	<b>[INH]</b> • <b>[ON]</b>	Mode: RON • N/I					

TRAINER FUNCTION 教練模式		1CH	2CH	3CH	4CH	5CH	6CH
TRNR	Servo Reverse 伺服器正反轉	<b>[INH]</b> • <b>[ON]</b>	NOR • FNC • OFF	NOR • FNC • OFF	NOR • FNC • OFF	NOR • FNC • OFF	NOR • OFF

## BATTERY 電池:ALIGN LI-POLY 11.1V 2250MAH

Motor Gear 馬達齒	Main Rotor Blade 主旋翼規格	PITCH 螺距	Current(A) approx. 電流(A)大約值	Throttle Curve 油門曲線	RPM approx. 主旋翼轉速大約值	
11T	325 Carbon fiber blades-blue 325 碳纖維主旋翼-藍	Hover 停懸	+5°	10.5	040/65/80/100%	2300
		IDLE	0°	15		100/100/100/100/100%
			±9°	27.0	3280	
			±11°	32.0	3120	

NOTE: Please use a pitch gauge to adjust the pitch value. Incorrect excess pitch setting will result poor helicopter performance and reduce ESC's life and battery's life.

註: 請務必使用螺距規來測量調整螺距, 不正確的過大螺距設定不但無法發揮直昇機的特性, 反會影響到無刷調速器與電池的壽命。

## RCM-BL 450MX MOTOR 無刷馬達

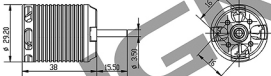

(Unit:mm)  
(單位:mm)

## SPECIFICATION 尺寸規格

KV	KV值	3400KV(RPM/V)	Input voltage	輸入電壓	3S-4S
Stator Arms	磁鋼片槽數	9	Magnet Poles	磁鐵極數	6
Max continuous current	最大持續電流	46A	Max instantaneous current	最大瞬間電流	68A(5sec/5秒)
Max continuous power	最大持續功率	500W	Max instantaneous power	最大瞬間功率	730W(5sec/5秒)
Dimension	尺寸	Shaft $\phi 3.5 \times 29.2 \times 53.5 \text{mm}$	Weight	重量	Approx. 83g

## 15.RCE-BL35P BRUSHLESS SPEED CONTROLLER INSTRUCTION MANUAL 無刷調速器使用說明

## PRODUCT FEATURES 產品特色

- 5-6V step-less adjustable BEC output allows custom voltage setting to match servo specification.
- BEC output utilizes switching power system, suitable for 7.4-14.8V (2S-4S) Li battery, with continuous current rating of 3A, and burst rating of 5A.
- Three programmable throttle speed settings to support quick throttle response.
- Include soft start and governor mode.
- Small and compact PCB are designed for lightweight and simple installation.
- Large heat sink for optimum thermal performance.
- Highly compatible to work with 98% of all brushless motors currently on the market.
- Ultra-smooth motor start designed to run with all kinds of brushless motors.
- The power inlet utilizes a Japanese made "Low ESR" capacitor in order to provide stable power source.
- The throttle has more than 200 step resolution that provides great throttle response and control.
- 5-6伏特無段可調式BEC輸出, 可依伺服器規格與所需的特性自行設定電壓。
- BEC輸入選擇用交換式電源設計, 適用7.4~14.8V(2S-4S)鋰電, 持續耐電流3A, 瞬間5A。
- 三段可程式油門反應速度, 使動力的反應精確精調。
- 具備啟動及Governor Mode定速功能。
- 體積小, 窄型設計, 安裝於機身容易。
- 有散熱片設計, 可延長電機壽命。
- 超高相容性, 可對應市面上市98% 無刷馬達。
- 絕佳起步設計, 無論國產、進口、內轉、外轉馬達皆起步順暢。
- 電池電源端採用日製 Low ESR 低阻抗電解電容, 大幅提升高電壓之穩定性。
- 油門達 200 段以上解析度, 原標之油門感應。

## WIRING ILLUSTRATION 接線示意圖



## SPECIFICATION 尺寸規格

Model 型號	Continuous Current 持續	Peak Current 瞬間	BEC Output BEC輸出	Dimension 尺寸	Weight 重量
RCE-BL3SP	35A	45A	Output voltage: 5-6V step-less adjustment Continuous current 3A; Burst current 5A 輸出電壓: 5~6V 無段階可調式 承受電流: 持續 3A、瞬間 5A	58x22x11mm	30g

- Good temperature situation for working at the maximum current.
- Supporting motor types: 2-10 pole in/outrunner brushless motors.
- Supporting motor RPM: 2 pole → 190,000 rpm ; 6 pole → 63,000 rpm.
- Input voltage: 5.5V ~ 16.8V(2-4S Li-Po)

- 持續最大電流需在機體散熱良好情況下。
- 支援馬達型號: 二極至十極無刷馬達。
- 支援馬達轉速: 二極→190,000rpm; 六極→63,000rpm。
- 輸入電壓: 5.5V-16.8V(2~4s Li-Po)

NOTE: 1. When setting to the Quick throttle response speed, the accelerative peak current will increase.  
2. To minimize possible radio interference induced by switching power system, BEC should be installed at least 5cm away from the receiver. The use of 2.4G receiver is recommended.

注意: 1. 設定為高油门反應速度時, 加速瞬間電流會有增大情形。  
2. 內置 Switching BEC, 安裝時請與接收器保持至少 5cm 以上的距離, 避免干擾接收器 (建議使用較穩定的 2.4G 系統接收器)。

## FUNCTIONS 產品功能

- Brake Option :** 3 settings that include Brake disabled/Soft brake/Hard brake.
- Electronic Timing Option :** 3 settings that include Low timing/Mid timing/High timing. Generally, 2 pole motors are recommended to use low timing, while 6 or more poles should use Mid timing. High timing gives more power at the expense of efficiency. Always check the current draw after changing the timing in order to prevent overloading of battery.
- Battery Protection Option :** 2 settings that include Li-Ion, Li-poly High/Middle cutoff voltage protection. The default setting is high cutoff voltage protection. CPU will automatically determine cell number of input Lithium battery (2S-4S). This option will prevent over-discharge of the battery. The following reference is the guideline for setting the Battery Protection option.
- Li-Ion/Li-poly High cutoff voltage protection:** When the voltage of single cell drops to 3.2V, the first step of battery protection mode will be engaged by the ESC resulting in reduced power. The pilot should reduce the throttle and prepare landing. If the voltage of single cell drops to 3.0V, the second step of battery protection mode will be engaged resulting in power cutoff. (\*Note 1) For 11.1V/3cells Lithium battery, the full charged voltage will be approximately 12.6V. According to this input voltage, CPU will determine that this is a 3 cell battery.
- First step protection: 3.2V x 3cell=9.6V**  
**Second step protection: 3.0V x 3cell=9.0V.** When the voltage drops to 9.6V, the power will be reduced. When the voltage drops to 9.0V, the power will be cut off.
- Li-Ion/Li-poly Middle cutoff voltage protection:** This option is same as instruction 3-1, but when the voltage of single cell drops to 3.0V, the first step of battery protection will be engaged. When the voltage of single cell drops to 2.8V, the second step of battery protection will be engaged. (\*Note 1)
- Note: this option is only suitable for a fully charged battery pack in good working condition.
- Aircraft Option :** 3 settings that include Normal Airplane / Helicopter 1 / Helicopter 2. Normal Airplane Mode is used for general airplanes and gliders. When flying Helicopters, you can choose Helicopter 1 Mode, or Helicopter 2 Mode. Helicopter 1 Mode provides Soft Start feature. Helicopter 2 Mode provides Soft Start and Governor Mode.
- Throttle response speed :** 3 settings that include standard/ Medium/ Quick throttle response speed. The default setting is "quick speed". Use this option to adjust the setting according to flight character. For example, setting at Medium or Quick speed for 3D and powerful flight to make the power response more quickly, but note the accelerative peak current and power expense will increase.

- 煞車設定: 三段選擇分為無煞車 / 軟性煞車 / 急煞車
- 齒角設定: 三段選擇分為低齒角 / 中齒角 / 高齒角設定時機分為二極及六極以上馬達為標準。二極齒角則馬達一般用高齒角。若使用高轉速馬達, 可將齒角設定為中齒角。六極以上無刷馬達一般適用中齒角。若使用高轉速馬達, 可將齒角設定為高齒角。然而齒角之調整與電流及電壓之變化, 避免電池過熱, 影響電池及馬達壽命。
- 電池保護電壓設定: 二段選擇分為 Li-Ion、Li-Po 高截止電壓保護 / 中截止電壓保護 / 低截止電壓保護: 此功能會自動判定所輸入電池的 cell 數 (2-4S), 並提供使用者對於電池之充電保護, 以避免因放電電壓過低而造成電池損壞。以下為設定之解讀:
- 3-1 Li-Ion/Li-Po 高截止電壓保護: 普通電瓶 cell 數標準 3.2V 時, 電瓶啟動第一階段保護, 使動力開始中斷, 此時使用者應將油门减小, 準備降落; 高齒角 cell 電壓持續降低到 3.0V 時則會啟動第二階段保護, 完全限制動力輸出 (註 1); 若在 4-1 選擇 "一般飛機模式" 下才會啟動第二階段保護。
- 例: 以一部使用 11.1V 3cell 鋰電池之系統而言 11.1V 鋰電池充滿電約 12.6V, 此輸入電壓 CPU 會自動判定為 3cell 電瓶。  
第一階段保護: 3.2V x 3cell = 9.6V  
第二階段保護: 3.0V x 3cell = 9.0V 當電壓降至 9.6V 時, 動力會開始性中斷, 當電壓降至 9.0V 時則完全限制動力輸出。
- 3-2 Li-Ion/Li-Po 中截止電壓保護: 將 3-1 功能關閉, 但單 cell 電壓降至 3.0V 時, 會啟動第一階段保護, 單 cell 電壓降至 2.8V 時則會啟動第二階段保護 (註 1)。  
注意: 以上功能僅適用於充電電, 且功能正常的鋰電池。
- 飛機模式設定: 三段式選擇分為: 一般飛機模式 / 直昇機模式 1 / 直昇機模式 2 使用於一般飛機或滑翔機時, 請設定於一般飛機模式, 使用於直昇機時可選擇直昇機模式 1; 具有自動收斂功能, 或直昇機模式 2; 具有自動收斂及 Governor Mode 定速功能。
- 油门反應速度設定: 三段選擇分為標準 / 中速 / 快速由設定值為 "快速" 油门反應速度。此功能提供使用者依所需的飛行特性來作適當的調整, 例如 3D 飛機與劇烈的 3D 直昇機飛行時可設定為中速或快速, 使動力反應更加快速、靈敏, 但需注意高油门反應速度時, 加速瞬間電流與耗電量會有增大的情形。

6. **BEC output voltage setting : 5-6V step-less adjustment.**  
This option allows custom voltage setting. Default setting is 5.5V; please adjust the voltage according to the specification of the servo (speed and resistance). Prior to entering the setup mode, a voltmeter needs to be connected to the power inlet of the receiver (as illustration) to monitor the selected voltage. The voltage is set by varying the throttle stick position from low (5V) to high (6V).

The voltmeter needs to be connected to any un-use inlets "+" and "-" to measure the selected voltage.

將電壓表連接到任一未使用過之 "+" 與 "-" 插口，以量測所選擇的電壓。



**NOTE : Certain servos are designed to work with high voltage, while other servos are designed for lower voltage. To avoid damage to servos, please follow the servo's factory specification to determine the proper voltage setting.**

注意：部份伺服器不適合較高的電壓下操作，請依原廠適用電壓規格設定，避免造成伺服器燒毀。

7. **Thermal Protection :** When the ESC temperature reaches 80 °C for any reason, it will engage the battery protection circuit, reducing power to the ESC. We recommend mounting the ESC in a location with adequate air flow and ventilation.
8. **Safe Power On Alarm :** When the operator turns on the ESC, it will automatically detect the transmitter signal. The ESC will emit a confirmation tone and enter normal operation mode if the throttle is set to the lowest position. If the throttle position is at full throttle, it will begin to enter Setup Mode. If the throttle is in any other position, the ESC will emit an alarm and not enter user mode for safety precautions.
9. **Aircraft Locator :** If the aircraft should land or crash in an unexpected location and become lost, the pilot can enable the Aircraft Locator Option. The aircraft locator option is engaged by turning off the transmitter. When the ESC does not receive a signal from the transmitter for 30 seconds, it will start to send an alarm to the motor. The sound of the alarm will aid the pilot to locate the aircraft. This option will not work with a PCM receiver that has SAVE function enabled, or with low noise resistant PPM receivers.

7. **過熱保護：**當電壓因不虞之空氣對流或過熱輸出導致溫度上升達 80 °C 時，電壓會啟動過熱保護，而降低動力輸出中斷，建議將電壓裝置在機體內空氣對流之位置，並實際使用高流速風扇輸出電流，以達到電壓之最佳效率。
8. **防燒巧保護警報功能：**於使用者開啟電壓電源時，系統會自動偵測射機之設定，如果射機油門未處於最低點，或未處於最低點，系統將進入設定模式，馬達將不會轉動，同時會發出警報音響。
9. **尋機功能：**當飛機降落在長草區或難以自視規定時，使用者可關閉射機開關，當電壓無法接收來自接收機信號時，電壓會約三十秒後從馬達發出警報音響，以定位它。此功能不適用於啟用了 SAVE 功能之 PCM 接收機，或抗雜訊低之 PPM 接收機。

## SETUP MODE 設定模式

1. **Setup mode :** Make sure to connect the ESC to the throttle channel of the receiver. Please refer to the user manual of your radio system. The second step is to connect the 3 power-out signal pins to the brushless motor. Before you turn on the transmitter, please adjust the throttle stick to the maximum full throttle position. Proceed to connect the battery to the ESC. You will hear confirmation sounds as soon as you enter the SETUP MODE. Please refer to page 30 for details.
2. **Throttle stick positions in Setup mode :** Setup mode includes six settings: Brake, Electronic Timing, Battery Protection, Aircraft, Throttle Response Speed and BEC output voltage. Every setting has three options. Simply place the throttle stick in the highest, middle, and lowest positions for each setting. For example, first brake setting (Hard): move the stick to the highest position. Then timing setting (mid): move the throttle stick in the middle position.

1. **進入設定模式：**將電壓與接收器之油門 Channel 連接，不須之接收系統請參閱您系統之使用手冊，馬達之三線線與電壓連接，將發射器之油門桿推桿到最高點，使之於全油門狀態，先關閉發射器電源，再將電壓連接至電壓，進入設定模式，馬達將有設定模式之提示音響，請參考第 30 頁格式化設定模式說明。
2. **設定模式中之動作：**設定模式共有六項設定，分別為：煞車、馬達進角、電池保護、飛機模式、油門反應速度及 BEC 輸出電壓等設定，詳細內容請參考各項功能之解說，每一項設定中各含三段設定，各項設定以油門桿之上、中、下位置來決定其設定值，例如：煞車設定時，油門桿推桿至最高，將設定為煞車，進入第二段進角設定時，油門桿推桿至中位，則設定為中進角。

Mode 設定模式	Throttle position 油門桿位	Low 低	Middle 中	High 高
Brake 煞車設定		● Brake disabled(1-1) 煞車禁用(1-1)	Soft brake(1-2) 軟性煞車(1-2)	Hard brake(1-3) 急煞車(1-3)
Electronic Timing 進角設定		Low-timing(2-1) 低進角(2-1)	● Mid-timing(2-2) 中進角(2-2)	High-timing(2-3) 高進角(2-3)
Battery Protection 電池保護電壓設定		● High cutoff voltage protection(3-1) 高截止電壓保護(3-1)	Middle cutoff voltage protection(3-2) 中截止電壓保護(3-2)	
Aircraft 飛機模式設定		Normal Aircraft/Glider(4-1) 一般飛機/滑翔機(4-1)	● Helicopter 1 (Soft Start)(4-2) 直升機模式 1 有緩啟動功能(4-2)	Helicopter 2 (Soft Start+ Governor Mode)(4-3) 直升機模式 2 有緩啟動+Governor Mode 主動功能(4-3)
Throttle response speed 油門反應速度設定		Standard(5-1) 標準(5-1)	Medium speed(5-2) 中速(5-2)	● Quick speed(5-3) 快速(5-3)
BEC output voltage BEC 輸出電壓設定		5.0V	● 5.5V	6.0V

Note: "●" Default setting  
註: "●" 表示出廠設定值

Chart A  
表 A

## ESC START-UP INSTRUCTION 開機使用模式

Ensure the throttle stick is at the lowest position.  
Switch on transmitter.  
打開電源，並將桿推至最低點，準備進入使用模式。



Connect battery power to ESC  
接連發送上電源，再連響發提示



Current Settings Indicator Beeps  
升空使用模式響發提示

First mode sound (Brake)  
Second mode sound (Timing)  
Third mode sound (Battery protection)  
Fourth mode sound (Aircraft)  
Fifth mode sound (Throttle response speed)  
No sound for BEC output voltage

第一種響發提示 (煞車)  
第二種響發提示 (時機)  
第三種響發提示 (電池保護)  
第四種響發提示 (飛機)  
第五種響發提示 (油門響應速度)  
無響發提示 (BEC輸出電壓)

## CURRENT SETTINGS INDICATOR BEEPS EXPLANATION 開機模式設定響發提示說明

First Beep Group Brake Status  
第一種響發 煞車設定狀態提示



Second Beep Group Electronic Timing  
第二種響發 時機設定狀態提示



Third Beep Group Battery protection Cut-off  
第三種響發 電池保護截止狀態提示



Fourth Beep Group Aircraft Status  
第四種響發 飛機設定狀態提示



Fifth Beep Group Throttle Response  
第五種響發 油門響應速度設定狀態提示



## INSTRUCTIONS ON AIRCRAFT MODE SETTINGS 飛機模式設定使用說明

**Normal Airplane/Glider Mode (Option 4-1):**  
This option is applied to general airplanes and gliders.

**Helicopter 1 Mode (Option 4-2):**  
This option provides a soft start feature and is applied to Helicopters for Normal, Idle Up 1, or Idle Up 2 modes. Please note that the sensitivity of the gyro should be set lower when flying in Idle Up 1 or Idle Up 2 modes if tail hunting (wag) occurs due to higher rotor speed.

**Helicopter 2 Mode (Option 4-3):**  
This option supports soft start as well as Governor Mode features and is applied to Helicopters for Idle Up 1 and Idle Up 2 modes (not suitable for Normal Flight Mode). When Governor Mode is in use, the throttle should be set between 75% and 85%. Again if tail wag occurs, lower the sensitivity of the gyro to eliminate the hunting effect. The Governor Mode may not work properly in cases of insufficient rotor speed (due to improper gear ratio), poor battery discharge capability, and improper setting of gyro sensitivity and the blade pitch, etc. Please make sure all the proper adjustments have been done when using Governor Mode.

- 一般飛機模式(選項4-1): 適用於一般飛機及滑翔機。
- 直升機模式1 (選項4-2): 具有緩啟動功能，適用於Normal、Idle1、Idle2等飛行模式。當切換至Idle1或Idle2模式，如有較高轉速造成陀螺儀有輕微的追獵現象，此時應將陀螺儀的感度設定分別降低。
- 直升機模式2 (選項4-3): 具有緩啟動及Governor Mode設定功能，適用於Idle1、Idle2特技飛行模式(不適合Normal飛行模式下應用)。選擇定速功能時，油門應定速在75%-85%之間。如果飛行時發現有輕微的追獵現象時，應降低陀螺儀的感度；由於轉速不足(齒比搭配不當)，電池效能不佳，陀螺儀感度設定不當，Pitch設定錯誤，皆會導致無法發穩定速的功能，甚至產生尾部偏擺的情形，所以選擇此模式時應針對相關條件進行確認。

## SETUP MODE 程式化設定模式

MINIMUM 4 CHANNEL RADIO IS REQUIRED 四數以上標準發射器均可執行設定

<p>Place the throttle stick to the highest position. Switch on transmitter. 將油門桿推至最高點，打開電源。</p>	<p>Connect battery to ESC 接連發送上電源，再連響發提示</p> <p>Power on sound 開機音響</p> <p>Transmitter Mode 進入設定模式</p>	<p>Throttle channel adjustment process, the highest position acknowledge sound. 油門通道調整過程，油門桿推至最高點，響發提示音響</p>	<p>Place the throttle stick to the lowest point. 將油門桿推至最低點，響發提示音響</p>	<p>Use throttle stick to set preferred Brake Mode within the 5 times. A confirmation sound will lock in when finish. 將油門桿推至所喜好的煞車模式，在5次之內響發提示音響，此時油門桿推至最低點，響發提示音響，此時油門桿推至最低點，響發提示音響</p>
<p>Use throttle stick to set preferred Timing Mode within the 5 times. (Refer to Chart A) A confirmation sound will lock in when finish. 將油門桿推至所喜好的時機模式，在5次之內響發提示音響，此時油門桿推至最低點，響發提示音響，此時油門桿推至最低點，響發提示音響</p>	<p>Use throttle stick to set preferred Battery Protection Mode within the 5 times. (Refer to Chart A) A confirmation sound will lock in when finish. 將油門桿推至所喜好的電池保護模式，在5次之內響發提示音響，此時油門桿推至最低點，響發提示音響，此時油門桿推至最低點，響發提示音響</p>	<p>Use throttle stick to set preferred Aircraft Mode within the 5 times. (Refer to Chart A) A confirmation sound will lock in when finish. 將油門桿推至所喜好的飛機模式，在5次之內響發提示音響，此時油門桿推至最低點，響發提示音響，此時油門桿推至最低點，響發提示音響</p>	<p>Use throttle stick to set preferred Throttle Response Speed Mode within the 5 times. (Refer to Chart A) A confirmation sound will lock in when finish. 將油門桿推至所喜好的油門響應速度模式，在5次之內響發提示音響，此時油門桿推至最低點，響發提示音響，此時油門桿推至最低點，響發提示音響</p>	<p>Use throttle stick to set preferred BEC Output Voltage Mode within 5 times. (Refer to Chart A) A confirmation sound will lock in when finish. 將油門桿推至所喜好的BEC輸出電壓模式，在5次之內響發提示音響，此時油門桿推至最低點，響發提示音響，此時油門桿推至最低點，響發提示音響</p>

**STEP 1 步驟1**

Turn on Transmitter, and then 3GX MRS power.  
先開啟遙控器電源，再開啟3GX MRS電源。

**STEP 2 步驟2**

At this time, 3GX MRS BIND LED will lit steady green, and STATUS will lit steady green or steady red.  
此時3GX MRS BIND燈會綠燈恆亮，STATUS會綠或紅燈恆亮。

**STEP 3 步驟3**

As shown in diagram to the left, the washplate will twitch up and down 3 times after initialization to signal successful startup. If washplate twitches up and down 3 times with washplate tilted, check for correct servo installation as per instruction.

如左圖示，初始化完成後，十字盤會保持水平下小幅跳動三次，表示完成開機程序，如十字盤為傾斜跳動三次，請檢查伺服器是否依照指示安裝。

完成開機前直昇機螺絲固定無法動作，如果一直無法完成開機程序，請檢查開機時直昇機是否停止或訊號線未接妥，確認後重新開機。正常開機後，STATUS亮綠燈表示尾舵為鎖定模式，亮紅燈為非鎖定模式。

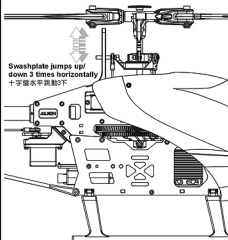

Swashplate jumps up/down 3 times horizontally  
十字盤水平跳動3下

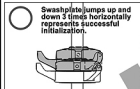

Swashplate jumps up and down 3 times horizontally represents successful initialization.



Swashplate jumps up and down 3 times tilted represents setup error.  
十字盤傾斜跳動三次代表伺服器安裝錯誤

Green LED indicates rudder lock mode  
綠燈為尾舵鎖定模式  
Red LED indicates non-rudder lock mode  
紅燈為尾舵非鎖定模式



**STEP 4 步驟4**

Tilt the helicopter forward and swashplate should tilt back to compensate. If reversed, perform the flybarless initial setup again and adjust the elevator reverse setting (Refer to page 26 E-REV setup)

將直昇機往前傾，陀螺儀應將十字盤向後修正，如果反向，請檢查3GX MRS是否依照指示安裝。

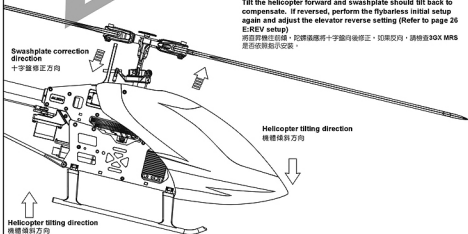

Swashplate correction direction  
十字盤修正方向

Helicopter tilting direction  
機體傾斜方向

Helicopter tilting direction  
機體傾斜方向



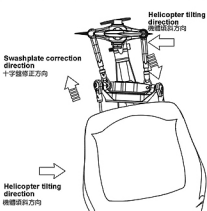

#### STEP5 步驟5

Tilt the helicopter right, gyro should tilt the swashplate left to compensate. If reversed, please check for the correct installation direction of 3GX MRS.

將直昇機往右傾，陀螺儀應將十字盤往左修正。如果反向，請檢查3GX MRS 是否依照指示安裝。

#### STEP6 步驟6

Check for proper CG location. CG needs to be at the center point below the main shaft.

檢視直昇機重心是否適當，請先調整直昇機重心位置至主軸中心線下方位置。

#### STEP7 步驟7

Confirm all functions are normal, power cycle the system, and begin flight test after initialization.

確認所有功能正常，重新開機，完成開機程序後進入飛行測試。

### HELICOPTER CG CHECK PROCEDURE 直昇機機體重心檢視方向

After installed the battery, hold the helicopter as shown. Once the helicopter stops rotating, the helicopter's CG can be seen at where the head is pointing relative to the main shaft.

電池安裝後，將直昇機如圖示舉起，等待直昇機停止轉動後檢視機頭方向，正確重心應落在機身（主軸附近）位置。

Adjust the frame's CG within  $\pm 60$  degrees from level.

以水平線上下夾角  $60^\circ$  內為適當的範圍來調整機體的重心。

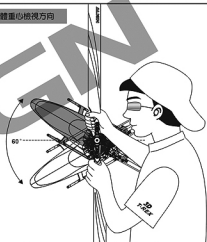

## 17. FLIGHT ADJUSTMENT AND SETTING 飛行動作調整與設定

ALIGN

### PLEASE PRACTICE SIMULATION FLIGHT BEFORE REAL FLYING 飛行前請先熟練模擬飛行











A safe and effective practice method is to use the transmitter flying on the computer through simulator software sold on the market. Do a simulation flight until you familiarize your fingers with the movements of the rudders, and keep practicing until the fingers move naturally.

1. Place the helicopter in a clear open field (Make sure the power OFF) and the tail of helicopter point to yourself.
2. Practice to operate the throttle stick (as below illustration) and repeat practicing "Throttle high/low", "Aileron left/right", "Rudder left/right", and "Elevator up/down".
3. The simulation flight practice is very important, please keep practicing until the fingers move naturally when you hear operation orders being call out.

在還沒瞭解直昇機各動作的操作方式前，嚴禁實機飛行。請先進行電腦模擬飛行的練習，一種最有效、最安全的練習方式，就是透過市面販售的模擬軟體，以遙控器在電腦上模擬飛行，熟悉各種方向的操控，並不斷的重複，直到手指可熟練的控制各個動作及方向。

1. 將直昇機放在空曠的地方(確認電源為關閉)，並將直昇機的機尾對準自己。
2. 練習操作遙控器的各桿桿(各動作的操作方式如下圖)，並反覆練習油门高低、副翼左/右、升降的前/後及方向舵左/右操作方式。
3. 模擬飛行的練習相當重要，請重複練習直到不需思考，手指能自然隨著喊出的指令移動控制。

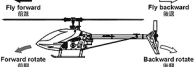
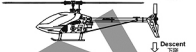

Mode 1	Mode 2	Illustration 圖示
 <p><b>Aileron 副翼</b></p> 	 <p><b>Elevator 升降/前後</b></p> 	 <p>Move left 左移 Rotate left 左翻</p> <p>Move right 右移 Rotate right 右翻</p>
 <p><b>Throttle 油門</b></p> 	 <p><b>Rudder 方向</b></p> 	 <p>Fly forward 前進 Forward rotate 前翻</p> <p>Fly backward 後退 Backward rotate 後翻</p>  <p>Ascent 上升 Descent 下降</p>  <p>Turn right 右旋 Turn left 左旋</p>

## FLIGHT ADJUSTMENT AND NOTICE FOR BEGINNERS 初學飛行調整與注意



- Check if the screws are firmly tightened.
- Check if the transmitter and receivers are fully charged.
- 兩次確認螺絲是否鎖緊？
- 發射器和接收器電池是否完全充電。

- When arriving at the flying field.
- 當抵達飛行場



If there are other radio control aircraft at the field, make sure to check their frequencies and tell them what frequency you are using. Frequency interference can cause your model or other models to crash and increase the risk of danger.

假使飛行場有其他遙控飛機，請確認他們的頻率，並告知他們您正在使用的頻率，相同的頻率會造成干擾導致失控和大大地增加風險。

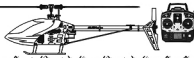

## STARTING AND STOPPING THE MOTOR 啟動和停止馬達



First check to make sure no one else is operating on the same frequency. Then place the throttle stick at lowest position and turn on the transmitter.

- Check the movement.
- 動作確認
- Are the rudders moving according to the controls?
- Follow the transmitter's instruction manual to do a range test.
- 方向舵是否隨著控制方向移動？
- 根據發射器說明書進行距離測試。

**ON! Step1**  
First turn on the transmitter.  
先開發射器



**ON! Step2**  
Connect to the helicopter power  
插上引擎發電源



Check if the throttle stick is set at the lowest position.  
確認油門搖桿是在最低的位置。

**OFF! Step3**  
Reverse the above orders to turn off.  
將電源開關請按上述操作動作反執行。



## MAIN ROTOR ADJUSTMENTS 主旋翼雙槳平衡調整



Tracking adjustment is very dangerous, so please keep away from the helicopter at a distance of at least 5m.  
調整軌跡非常危險，請於調整時與機離至少5公尺的距離。

- Before adjusting, apply a red piece of tape on one blade, or paint a red stripe with a marker or paint to identify on blade.
- Raise the throttle stick slowly and stop just before the helicopter lifts-off ground. Look at the spinning blades from the side of the helicopter.
- Look at the path of the rotor carefully. If the two blades rotate in the same path, it does not need to adjustment. If one blade is higher or lower than the other blade, adjust the tracking immediately.

- 調整時在其中一支主旋翼的翼端，貼上有顏色的膠紙或畫上顏色記號，方便雙槳調整辨識。
- 慢慢的推起油門桿桿到離地前且停止，在飛機即將起飛前，從飛機側面觀察主旋翼轉動。
- 仔細觀察雙旋翼軌跡的兩次高度及翼移動都是相同軌跡，則不需要調整；若不需要調整，則必須立刻調整軌跡。

- A. When rotating, the blade with higher path means the pitch is too big. Please shorten DFC ball link for regular trim.  
B. When rotating, the blade with lower path means the pitch is too small. Please lengthen DFC ball link for regular trim.

- A. 旋翼轉動時較高軌跡的主旋翼表示螺距(PITCH)過大，請將DFC連接桿修正。  
B. 旋翼轉動時較低軌跡的主旋翼表示螺距(PITCH)過小，請將DFC連接桿修正。



Incorrect tracking may cause vibrations. Please repeat adjusting the tracking to make sure the rotor is correctly aligned. After tracking adjustment, please check the pitch angle is approx.  $+4^{\circ}\sim 5^{\circ}$  when hovering.

不正確的旋翼軌跡會導致震動，請不斷重複調整軌跡，使旋翼軌跡精準正確。  
在調整軌跡後，確認一下Pitch角度在停懸時應為大約 $+4^{\circ}\sim 5^{\circ}$ 。



## FLIGHT ADJUSTMENT AND NOTICE FOR BEGINNERS 初學飛行調整與注意

During the operation of the helicopter, please stand approximately 10m diagonally behind the helicopter.  
飛行時，請站在對角線後方10公尺。



- Make sure that no one or obstructions in the vicinity.
- You must first practice hovering for flying safety. This is a basic flight action. (Hovering means keeping the helicopter in mid air in a fixed position)

- 確認鄰近地區沒有人和障礙物。
- 為了飛行安全，您必須先練習停懸，這是飛行動作的基本動作。停懸是指讓直升機在空中並保持固定位置。



Beginner may install a training landing gear to avoid any crash caused by offset effect while landing.  
必要時初學者可以在腳架下方安裝練習腳架，可避免降落時因重心偏移導致主旋翼或尾旋翼損毀。



## STEP 1 THROTTLE CONTROL PRACTICE 油門控制練習

When the helicopter begins to lift-off the ground, slowly reduce the throttle to bring the helicopter back down. Keep practicing this action until you control the throttle smoothly.

當直升機開始離地時，慢慢降低油門桿飛機降下。  
持續練習飛機從地面上升再下降直到覺得油門控制很順。

Mode 1

Mode 2



## STEP 2 AILERON AND ELEVATOR CONTROL PRACTICE 副翼和升降控制練習

- Raise the throttle stick slowly.
- Move the helicopter in any direction back, forward, left and right, slowly move the aileron and elevator sticks in the opposite direction to fly back to its original position.

- 慢慢升起油門桿。
- 使直升機朝後/前/左/右，慢慢的反向移動副翼和升降桿並將直升機回到原來位置。

Mode 1

Mode 2



- If the nose of the helicopter moves, please lower the throttle stick and land the helicopter. Then move your position diagonally behind the helicopter 5m and continue practicing.
- If the helicopter flies too far away from you, please land the helicopter and move your position behind 5m and continue practicing.
- 當直升機朝前移動時，請降低油門桿降落，然後移動自己的位置到對飛機的正後方5公尺再繼續練習。
- 假如直升機飛離你太遠，請先降落直升機，並到對飛機後5公尺再繼續練習。

## STEP 3 RUDDER CONTROL PRACTICING 方向舵操作練習

- Slowly raise the throttle stick.
- Move the nose of the helicopter to right or left, and then slowly move the rudder stick in the opposite direction to fly back to its original position.

- 慢慢升起油門桿。
- 將直升機朝左或右，然後慢慢的反向移動方向舵桿並將直升機回到原來位置。

## STEP 4

After you are familiar with all actions from Step1 to 3, draw a circle on the ground and practice within the circle to increase your accuracy.

◎ You can draw a smaller circle when you get more familiar with the actions.

當您覺得 Step1-3 動作熟悉了，在地上畫個圈並在這個圈內的範圍內練習飛行，以增加您操縱的準確度。

◎ 當您更加習慣操作動作，您可以畫更小的圈。



## STEP 5 DIRECTION CHANGE AND HOVERING PRACTICE 改變飛行機方向和練習停懸

After you are familiar with Step1 to 4, stand at side of the helicopter and continue practicing Step1 to 4. Then repeat the Step1 to 4 by standing in front of the helicopter.

當您覺得 Step1-4 動作熟悉了，站在對面飛行機側並繼續練習 Step1-4，之後，站在飛行機機頭前方重複步驟練習。



## 18. 3GX MR FLYBARLESS FLIGHT TEST PROCEDURE 飛行測試程序

**ALIGN**

### ELEVATOR AND AILERON GAIN ADJUSTMENT 升降及副翼陀螺儀感度調整

Hover the helicopter and observe if there are any left / right or forward / backward fast oscillation. If oscillation exists, turn the gain dial counter-clockwise to reduce the gyro gain.

先將飛行機以停懸飛行，觀察飛行機左右及前後是否有不正常快速抖動現象，如果前後或左右有抖動，請將感度旋鈕逆時針調整，以減少陀螺儀修正感度。

### SET THE DIAL TO 12 O'CLOCK POSITION AS STARTING POINT 建議初次飛行設於12點鐘方向

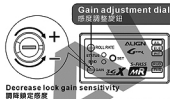

Decrease lock gain sensitivity.  
調降鎖定感度



Forward/back oscillation · Left/right oscillation  
前後晃動 / 左右晃動

### FORWARD STRAIGHT LINE FLIGHT 前進直線軌道飛行

After hovering, proceed to fast forward flight. Should there be similar oscillation, please reduce gain. Should the helicopter pitch up or experience slow response during flight, increase elevator gain. Repeat this process until ideal gain value is achieved. Similar method is used to set the aileron gain. After adjusting gyro gains, adjust the roll rate in 3GX Flight Mode settings based on your preference. Higher the roll rate, the faster the roll/flips are. Pilot can also adjust the cyclic EXP setting for the preferred stability. After all adjustments are completed, the pilot can enjoy the stability of slow flight and the fast agility from flybarless system.

停懸完成可快速前進飛行，同樣的如果有不正常抖動時，請將感度調小，飛行時如果有機頭向上仰起或反應遲滯現象時，請將感度調大，重複測試將感度調整至最佳理想，同樣方式可調整副翼感度旋鈕。調整完陀螺儀感度，可依據飛行官儀調整滾轉速率，調整越大，前進及左右滾轉速度越快，使用者也可依據個人經驗調整的EXP以增加停懸穩定性，完成所有調整後，就可享受Flybarless所提供低速飛行的穩定性及高速時的靈活性。



Forward Flight  
前進飛行

### ROLL RATE ADJUSTMENT 滾轉速率調整

Roll rate dial is used to adjust the roll rate of helicopter's elevator and aileron; turning clockwise will increase roll rate, with faster elevator and aileron response; turning counter-clockwise will decrease roll rate, with slower elevator and aileron response. We recommend novice pilots to fly with lower roll rate.

滾轉速率旋鈕調整升降，副翼滾轉速率，往前時針調大滾轉速率，升降與副翼動作反應會變快，往逆時針調小滾轉速率，升降與副翼動作反應會變慢，初學者建議把滾轉速率調低飛行。

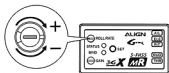

Adjust Counter-clockwise for less sensitive response  
逆時針調整，真昇機反應較緩和

## RUDDER SENSITIVITY ADJUSTMENT 尾舵敏感度調整

Actual gain value differs amongst servos and helicopters. The goal is to find the maximum gain without tail hunting.  
This can only be done through actual flight tests.  
The recommended starting point for transmitter's gyro gain setting should be 45-50% for hovering, 40-45% for IDLE UP.  
Value should be tuned under actual flight conditions by increasing to the maximum gain without tail hunting.

感度值的大小會隨著伺服機與直升機的不同而有所差異，一般而言，在不產生追蹤現象（直升機尾部出現左右搖擺的情況）的前提下感度值愈高愈好，所以只能透過實際飛行的狀況來進行調整。

進入遙控器感度設定的選項，剛開始停懸時建議先設定在45-50%左右，IDLE UP飛行時設定在40-45%左右，之後再依實際飛行的狀態再行修正，如果沒有追蹤現象發生時可再調整高感度，若發生追蹤現象時，則調低感度。

## 19.TROUBLESHOOTING 飛行中狀況排除

ALIGN

	Problem 狀況	Cause 原因	Solution 對策
Blade Tracking 雙槳平衡	Tracking is Off 置標	DFC linkage rods are not even length DFC連桿長度調整不平均	Adjust length of pitch linkage rods (A) 調整DFC連桿長度
Hover 停懸	Head speed too low 主旋翼轉速偏低	Excessive pitch 主旋翼的PITCH過高	Adjust pitch linkage rods (A) to reduce pitch by 4 to 5 degrees. Hovering headspeed should be around 2800RPM. 調整連桿A降低Pitch約4-5度(停懸時主旋翼轉速為約2800RPM)
		Hovering throttle curve is too low 停懸點油门曲線過低	Increase throttle curve at hovering point on transmitter (around 65%) 提高停懸點油门曲線(約65%)
	Head speed too high 主旋翼轉速偏高	Not enough pitch 主旋翼的PITCH過低	Adjust pitch linkage rods (A) to increase pitch by 4 to 5 degrees. Hovering headspeed should be around 2800RPM. 調整連桿A提高Pitch約4-5度(停懸時主旋翼轉速為約2800RPM)
		Hovering throttle curve is too high 停懸點油门曲線過高	Decrease throttle curve at hovering point on transmitter (around 65%) 降低停懸點油门曲線(約65%)
Rudder Response 尾舵反應	Drifting of tail occurs during hovering, or delay of rudder response when centering rudder stick. 停懸時尾舵出現一邊偏搖，或啟動動作時尾舵遲到或打回點時，尾翼產生搖擺，無法準確在所控制位置上。	Rudder neutral point improperly set 尾舵中立點設定不當	Reset rudder neutral point 重設尾舵中立點
	Tail oscillates (hunting, or wags) at hover or full throttle 停懸或全油门時尾翼左右來回搖擺。	Rudder gyro gain too low 尾舵陀螺儀感度偏低	Increase rudder gyro gain 增加尾舵陀螺儀感度
Oscillation during flight 飛行抖動	Helicopter oscillates forward/backward/left/right while performing cyclic maneuvers. 升旋或副翼打舵動作時，機體前後左右抖動	Swashplate gyro gain is slightly too high. 十字盤陀螺儀感度偏高，產生追蹤現象	Turn the gain dial on 3GX MRS counterclockwise, 10 degrees at a time until oscillation is eliminated. 逆時針調整3GX MRS上的感度調整旋鈕，以每次調整約10度的方式，調整至適當位置
	Helicopter front bobbles (nods) during forward flight. 直線飛行時，機頭點頭	Worn servo, or slack in control links 伺服器老化，控制結構有虛位	Replace servo, ball link, or linkage balls. 更換伺服器、連桿頭、球頭
Drifting during flight 飛行飄移	pitching up or aileron drift during forward flight 直線飛行機頭上揚或副翼飄移	Swashplate gyro gain is slightly too low 十字盤陀螺儀感度偏低	Turn the gain dial on 3GX MRS clockwise, 10 degrees at a time until drifting is eliminated. 順時針調整3GX MRS上的感度調整旋鈕，以每次調整約10度的方式，調整至適當位置
Control Response 動作反應	Slow Forward/Alt/Left/Right input response 前後左右飛行動作反應偏慢	Roll rate too low 滾轉速率偏低	Adjust 3GX MRS roll rate dial clockwise . 順時針調整3GX MRS滾轉速率旋鈕
	Sensitive Forward/Alt/Left/Right input response 前後左右飛行動作反應偏快	Roll rate too high 滾轉速率偏快	Adjust 3GX MRS roll rate dial counter . 逆時針調整3GX MRS滾轉速率旋鈕

If above solution does not resolve your issues, please check with experienced pilots or contact your Align dealer.

※在做完以上調整後，仍然無法改善情況時，應立即停止飛行並向有經驗的飛手諮詢或連繫您的經銷商。

# ALIGN

## Specifications & Equipment/規格配備:

Length/機身長:634mm

Height/機身高:205mm

Main Blade Length/主旋翼長:325mm

Main Rotor Diameter/主旋翼直徑:715mm

Tail Rotor Diameter/尾旋翼直徑:158mm

Motor Pinion Gear/馬達齒輪:11T

Main Drive Gear/帶動主齒輪:121T

Autorotation Tail Drive Gear/尾屬動主齒:106T

Tail Drive Gear/尾翼帶動齒:25T

Drive Gear Ratio/齒輪帶動比:1:11:4.24

Weight(w/o main blade)/空機重:540g

